



Optical Communications

Lecture 4

Engr. Madeha Mushtaq
Department of Computer Science
Iqra National University

Signal Degradation in Optical Fibers

- The Signal distortion mechanism in optical fibers cause optical signal pulses to broaden as they travel along a fiber.
- The signal distortion mechanism thus limits the information-carrying capacity of the fiber.



Signal Degradation in Optical Fibers

- Linear Effects: are the effects that are not dependent on power.
 - Attenuation
 - Dispersion
 - Non Linear Effects: are power dependent effects.
 - Parametric Effects
 - Scattering Effects
- 

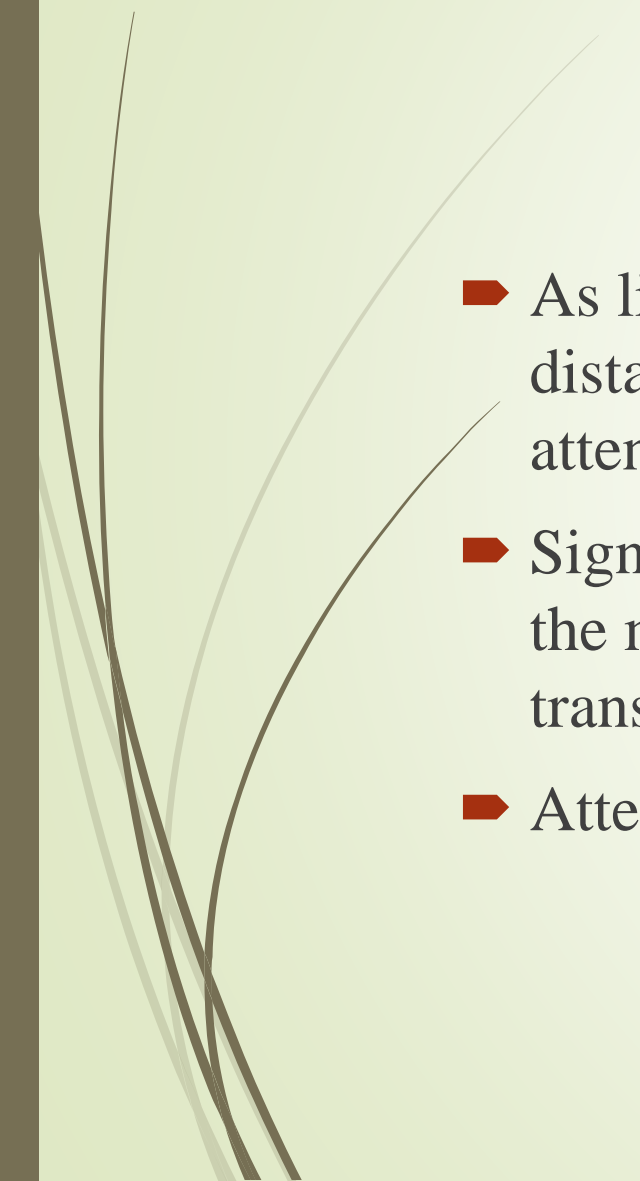

Attenuation

- As light travels along a fiber, its power decreases exponentially with distance. This reduction in signal power during transmission is called attenuation.
 - Signal attenuation (also known as fiber loss or signal loss) determines the maximum unamplified or repeaterless separation between optical transmitter & receiver.
 - Attenuation Limits the link length.
- 

Optical fiber attenuation vs. wavelength

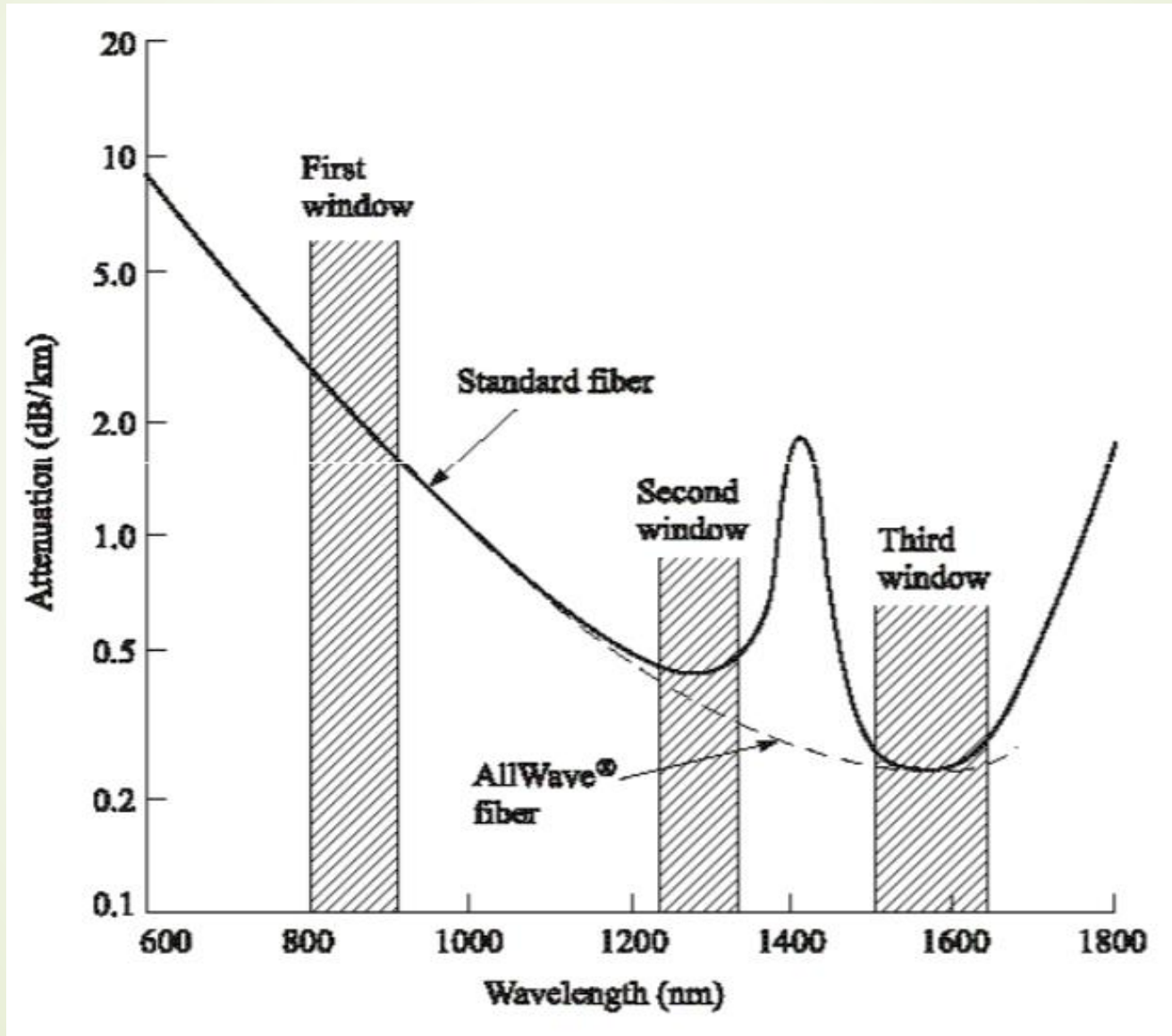

Attenuation is wavelength dependent, hence proper selection of operating wavelength is required.

Attenuation

- ▶ Basic attenuation mechanisms in optical fiber:
 - ▶ Absorption (Intrinsic & extrinsic)
 - ▶ Scattering (Linear & non linear)
 - ▶ Bending losses (Micro Bending & Macro Bending)

Absorption

- ▶ Material absorption is a loss mechanism related to the material composition and fiber fabrication process.
- ▶ This results in the dissipation of some of the transmitted optical power as heat in the waveguide.
- ▶ Absorption is classified into two basic categories:
 - ▶ Intrinsic Absorption
 - ▶ Extrinsic Absorption

Absorption

➤ Intrinsic Absorption:

- It is caused due to the interaction of free electrons within the fiber material and the light wavelength.
- The wavelength spectrum interacts differently with the atoms of the fiber material.

➤ Extrinsic Absorption:

- It is mainly due to the impurities injected into the optical fiber during the fabrication process.
- The metal ions are the most undesirable impurity in an optical fiber because the presence of metal ions influence and alter the transmission properties of the fiber. This results in loss of optical power.

Scattering Loss

- Scattering loss is the loss associated with the interaction of light with density fluctuations in the fiber.
- Small (compared to wavelength) variation in material density, chemical composition and structural inhomogeneity scatter light in other directions.

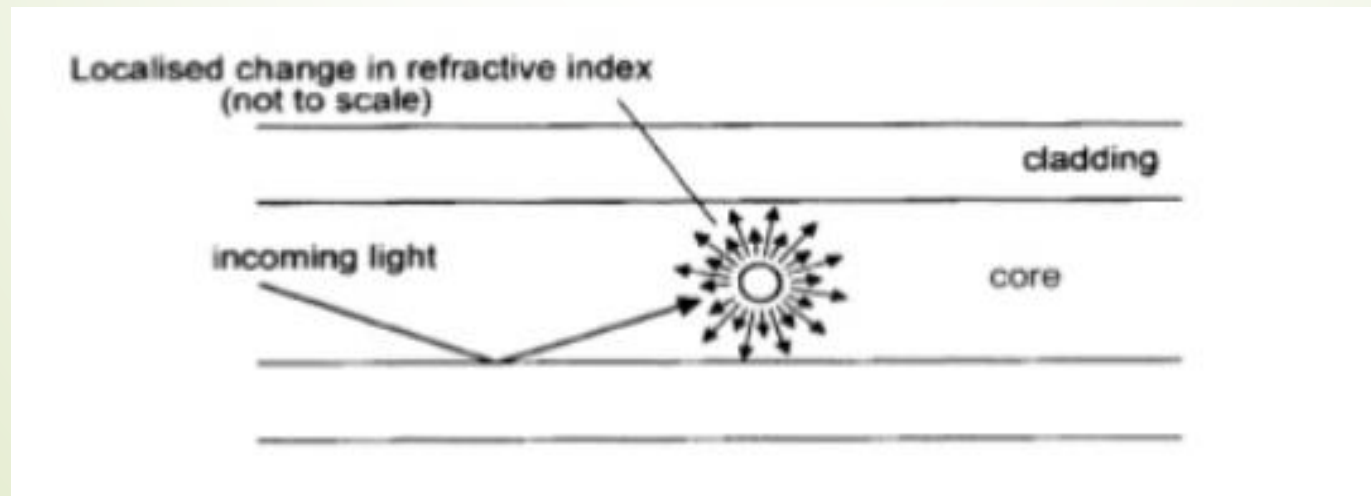

Absorption & scattering losses in fibers

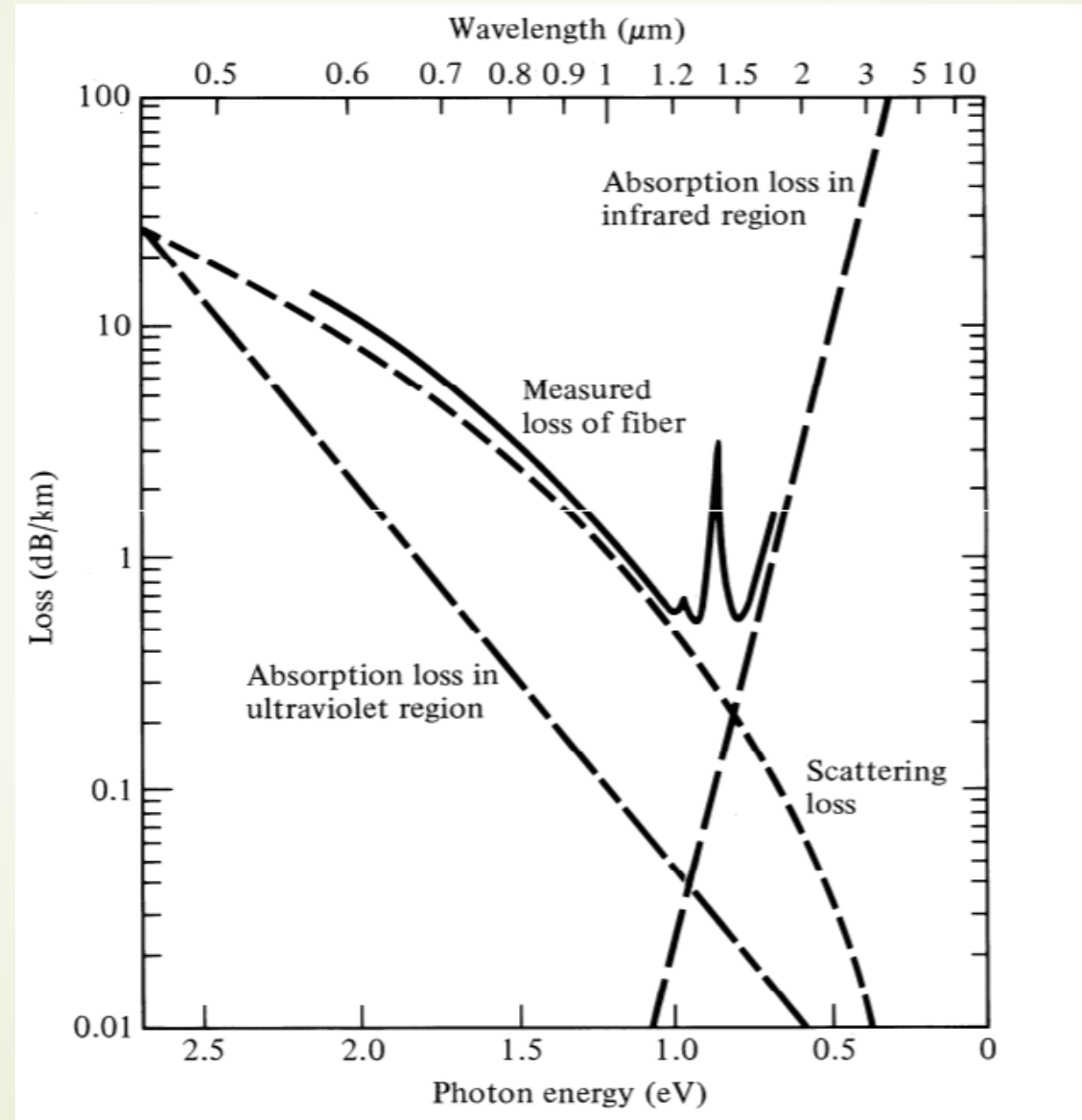

Bending Losses

- Radiative loss/bending loss occur whenever an optical fiber undergoes a bend of finite radius of curvature.
- Fibers can be subjected to two types of bends:
 - Macroscopic Bends and
 - Microscopic Bends

Bending Losses

- Macro Bending Losses:
 - It occurs due to the bends of radii larger than the fiber diameter.
 - These losses are also called “large curvature radiation losses.”
 - The macro bend losses occur when optical fibers are packed for transportation to the field of installation during the installation process.

Bending Losses

- Macro Bending Losses:
 - In micro-bend the bending is on micron scale, whereas in a macro bend the bending is on cm scale.
 - A typical example of a slow bend is a formation of optical fiber loop.

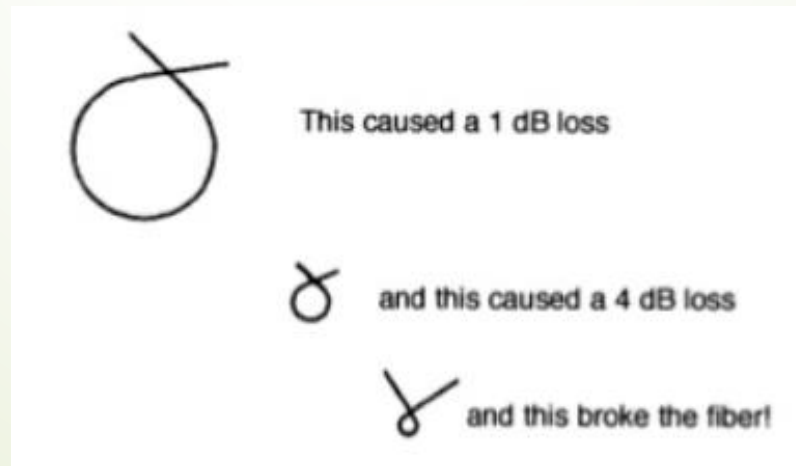

Bending Losses

➤ Micro Bending Losses:

- In a fiber without micro-bends the light is guided by total internal reflection at the core-cladding boundary.
- The rays which are guided inside the fiber has incident angle greater than the critical angle at the core-cladding interface.
- In the presence of micro-bends however, the direction of the local normal to the core-cladding interface deviates and therefore the rays may not have angle of incidence greater than the critical angle and consequently will be leaked out.

Bending Losses

- ▶ Micro Bending Losses:
 - ▶ These losses are associated with small perturbations of the fiber induced by the factors like uneven coating application or cabling induced stresses.

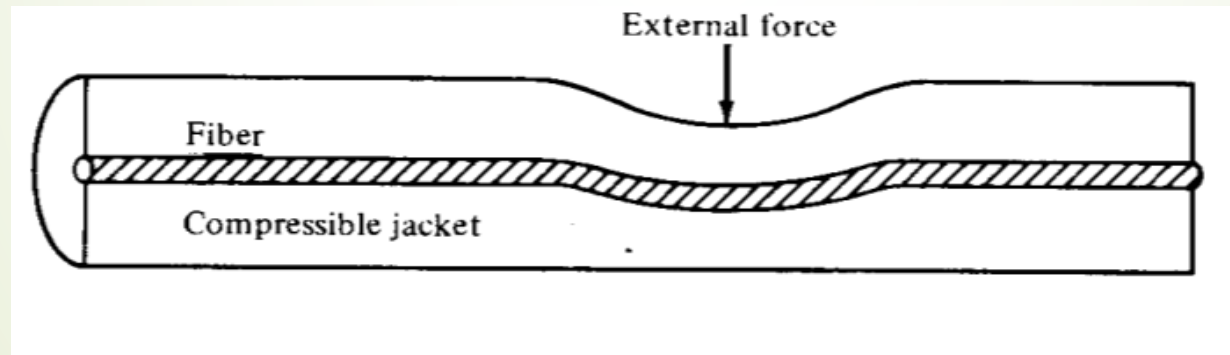

A compressible jacket extruded over a fiber reduces micro bending resulting from external forces.

Dispersion

- ▶ Any phenomenon in which the velocity of propagation of any electromagnetic wave is wavelength dependent.
- ▶ In communication, dispersion is used to describe any process by which any electromagnetic signal propagating in a physical medium is degraded because the various wave characteristics (i.e., frequencies) of the signal have different propagation velocities within the physical medium.
- ▶ Different frequency components travel at different speeds in fiber, arriving at different times at the receiver.

Dispersion

- ▶ There are 3 dispersion types in the optical fibers:
 - ▶ Material Dispersion
 - ▶ Waveguide Dispersion
 - ▶ Modal Dispersion

Dispersion & ISI

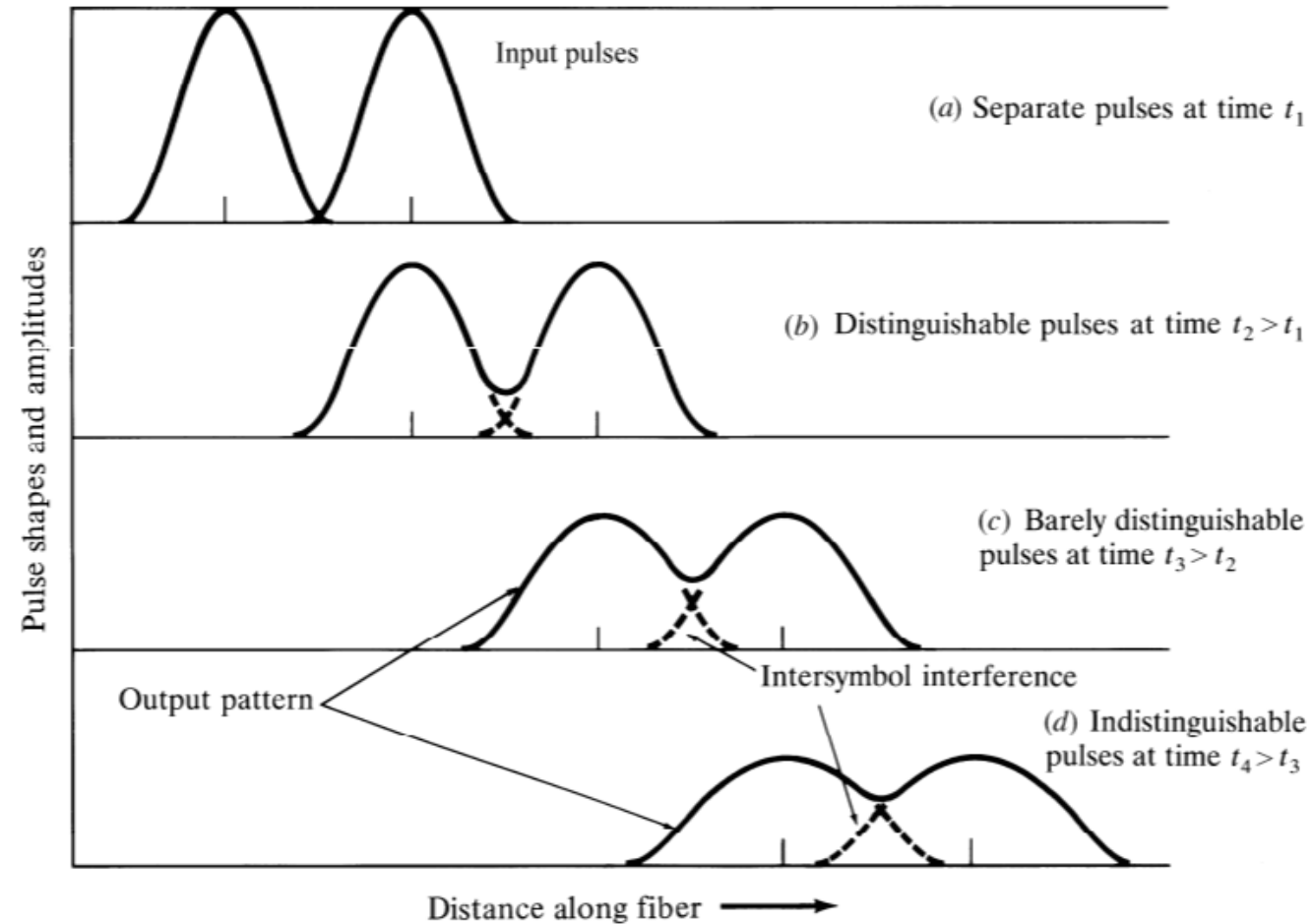

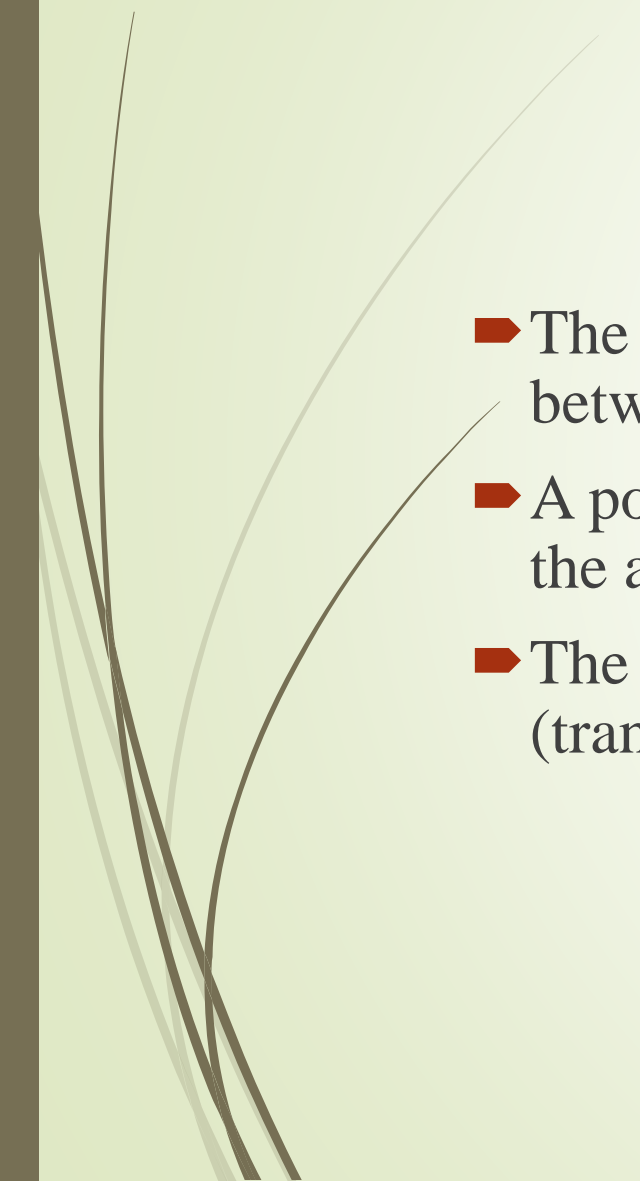

Power Budget

- ▶ The Fiber Optic Link power budget (PB) is simply the difference between the maximum and minimum signals that the FOL can transport.
 - ▶ A power budget, sometimes called a flux budget, is an accounting of all the attenuation and gains in a fiber-optic system.
 - ▶ The power budget refers to the amount of loss that a datalink (transmitter to receiver) can tolerate in order to operate properly.
- 

Power Budget

- In order to calculate power budget, we use a worst-case analysis to provide a margin of error, even though all the parts of an actual system do not operate at the worst-case levels.
- To calculate the worst-case estimate of power budget (P_B), you assume minimum transmitter power (P_T) and minimum receiver sensitivity (P_R):
- $P_B = P_T - P_R$



Power Budget

- ▶ There are numerous sources of losses in a fiber-optic cable system:
 - ▶ Cable losses
 - ▶ Connections between cable and light source and photodetector.
 - ▶ Connectors
 - ▶ Splices
 - ▶ Cable bends

Power Budget

▶ $LT = \alpha L + L_c + L_s$

▶ Definitions:

▶ LT - Total loss

▶ α - Fiber attenuation

▶ L - Length of fiber

▶ L_c - Connector loss

▶ L_s - Splice loss

Power Budget

- ▶ To calculate the power budget:
 - ▶ First, calculate all the losses; add all the decibel loss factors.
 - ▶ Also add a 4-dB contingency factor.
 - ▶ Calculate the power gain needed to overcome the loss:

$$\text{dB} = 10 \log P_t / P_r$$

where P_t is the transmitted power and P_r is the received power.

Testing The Power Budget For A Link

- In order to determine the power budget, we test the link under operating conditions and insert loss while watching the data transmission quality.
- Connect the transmitter and receiver with patch cords to a variable attenuator.

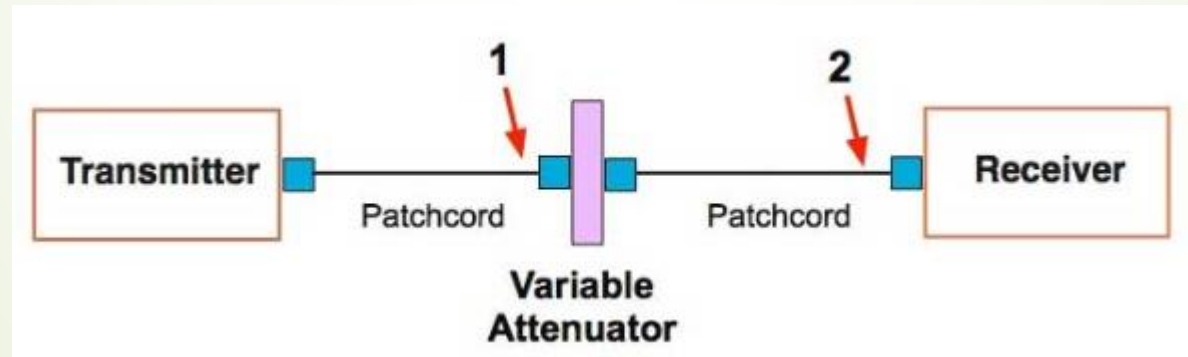

Testing The Power Budget For A Link

- Increase attenuation until you see the link has a high bit-error rate (BER for digital links) or poor signal-to-noise ratio (SNR for analog links).
- By measuring the output of the transmitter patch cord (point #1) and the output of the receiver patch cord (point #2), you can determine the maximum loss of the link and the maximum power the receiver can tolerate.
- A receiver must have enough power to have a low BER (or high SNR, the inverse of BER) but not so much it overloads and signal distortion affects transmission.

Testing The Power Budget For A Link





Regeneration and Amplification

- There are several ways to overcome the attenuation experienced by a signal as it travels over fiber-optic cable.
- Use newer types of cable that inherently have lower losses and fewer dispersion effects.

Regeneration and Amplification

- Use regeneration.
- Regeneration is the process of converting the weak optical signal to its electrical equivalent, then amplifying and reshaping it electronically, and retransmitting it on another laser.
- This process is generally known as optical-electrical-optical (OEO) conversion.

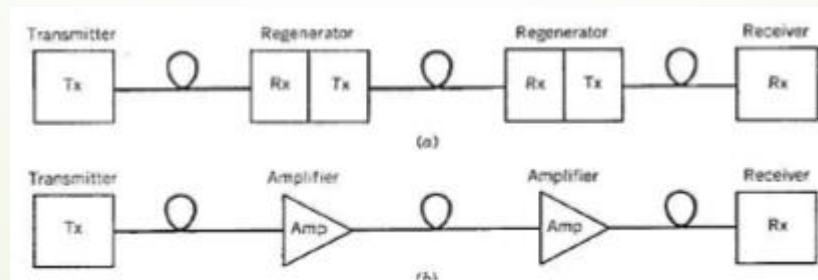

Regeneration and Amplification

- Use an optical amplifier (the best option).
- Optical amplifiers boost signal level without the need to first convert it to an electrical signal.
- Optical amplifiers are important in optical communication and laser physics.
- They are used as optical repeaters in the long distance fiber optic cables which carry much of the world's telecommunication links.



Regeneration and Amplification

- Types of Optical Amplifiers:
 - Semiconductor optical amplifiers (SOAs)
 - Fiber Raman and Brillouin amplifiers
 - Rare earth doped fiber amplifiers (erbium – EDFA 1500 nm, praseodymium – PDFFA 1300 nm)

Regeneration and Amplification

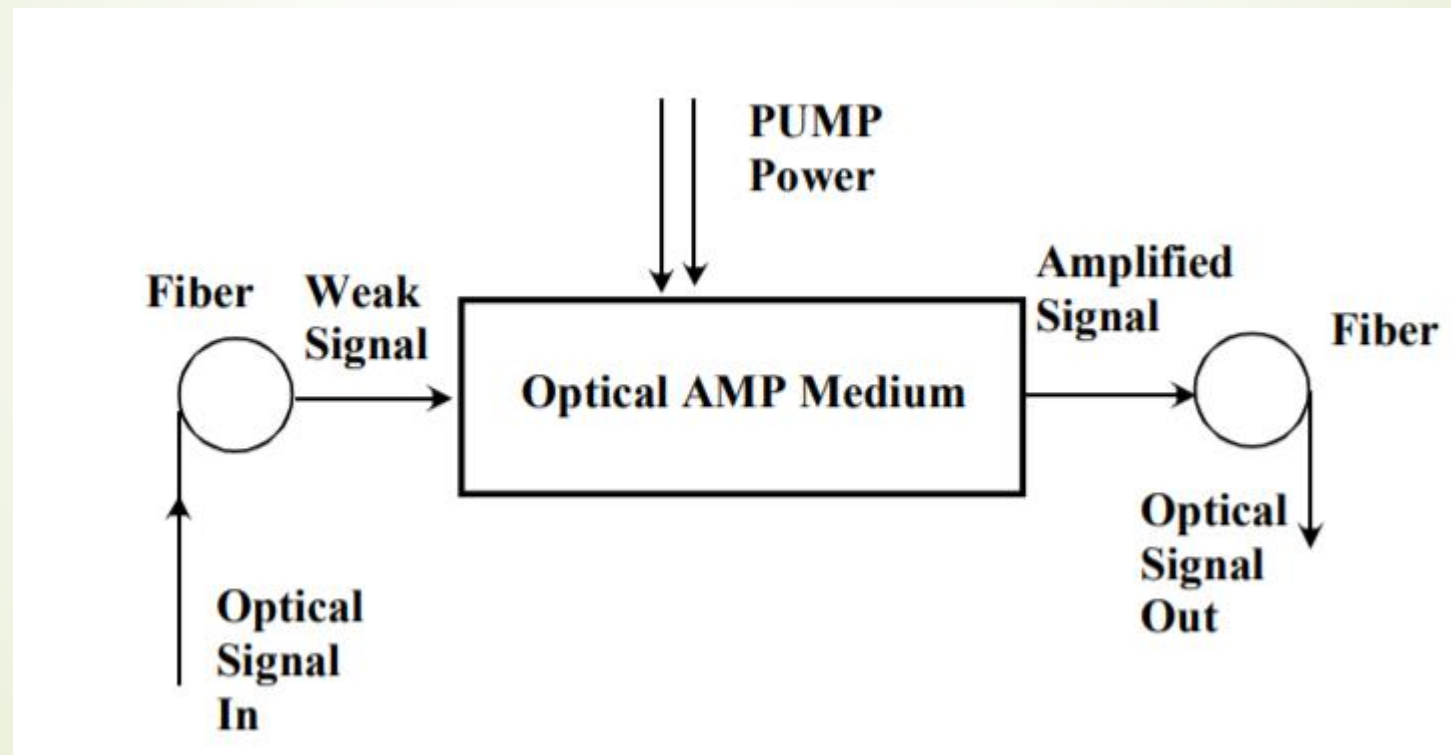

The general form of an optical amplifier



End Of Slides

