



INTRODUCTION OF BASIC DRAFTING



EDP CODE: 152007003
COURSE NAME: BASIC DRAFTING
ARCHITECT: NASEER ULLAH 

TOPICS TO BE COVERED

- BASIC DRAFTING DEF....
- GOALS OF TECHNICAL DWG
- TWO CLASSES OF DWGS
- DEFINITION AND RELATIONSHIP OF
- TOOLS NEEDED FOR DRAWING
- TITLE BLOCK AND BORDER
- DRAW A FREEHAND STARIGHTH LINE

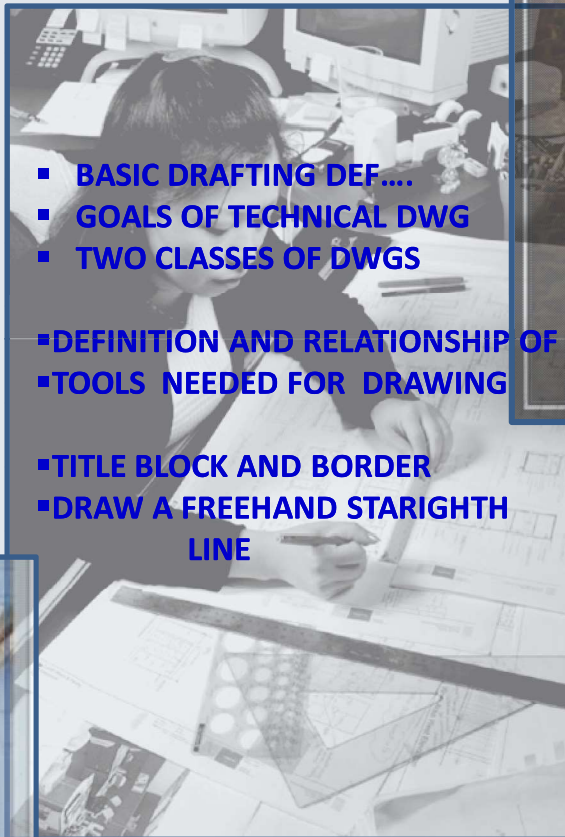
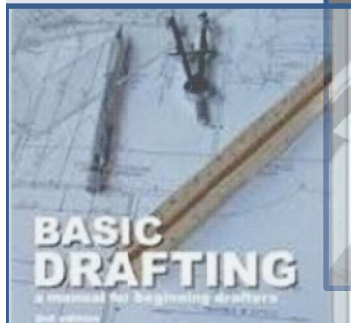

WHAT IS BASIC DRAFTING OR TECHNICAL DRAWING

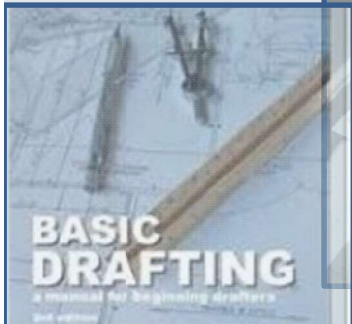
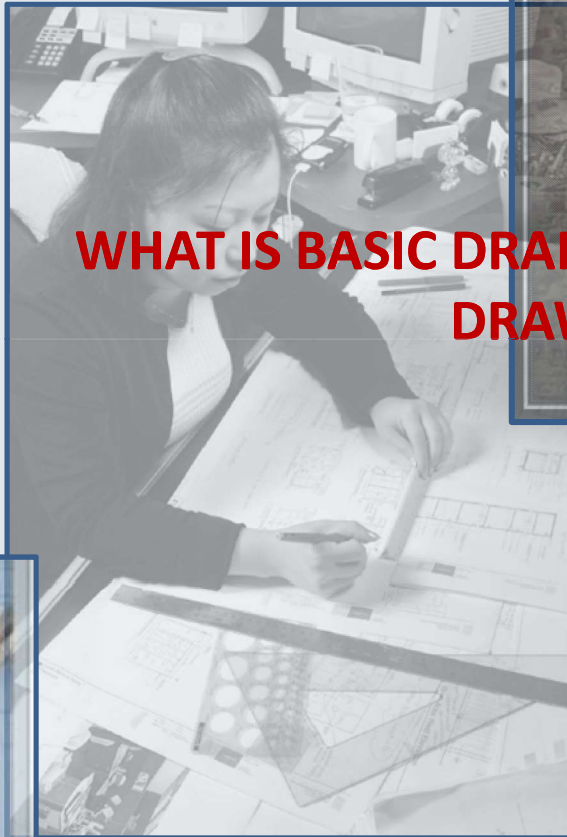



Technical drawing, drafting or drawing, is the act and discipline Of composing drawings that visually communicate how something functions or is constructed.

Technical drawing is essential for communicating ideas in **industry** and **engineering**. To make the drawings easier to understand, people Use familiar symbols, perspectives, units of measurement, notation systems, visual styles, and page layout.



GOALS OF TECHNICAL DRAWING

- Detail drawing must be accurate.
- Detail drawing must be executed with proper technique or good workmanship.
- Detail drawing should be neat.
- Detail drawing must be made with speed.



TWO CLASSES OF DRAWING

- ARTISTIC- The artist expresses aesthetic ideas or emotions.
- TECHNICAL- The technical drawing, on the other hand, is not subtle, or abstract.

It does not require an understanding of its creator, only an understanding of technical drawings.

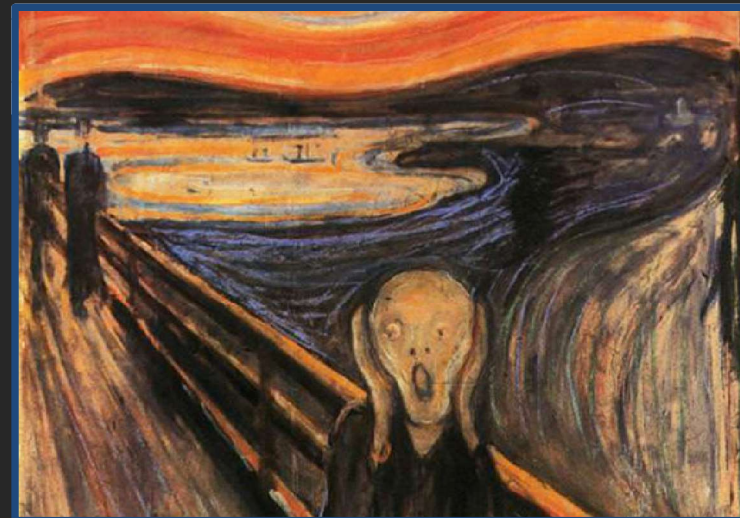
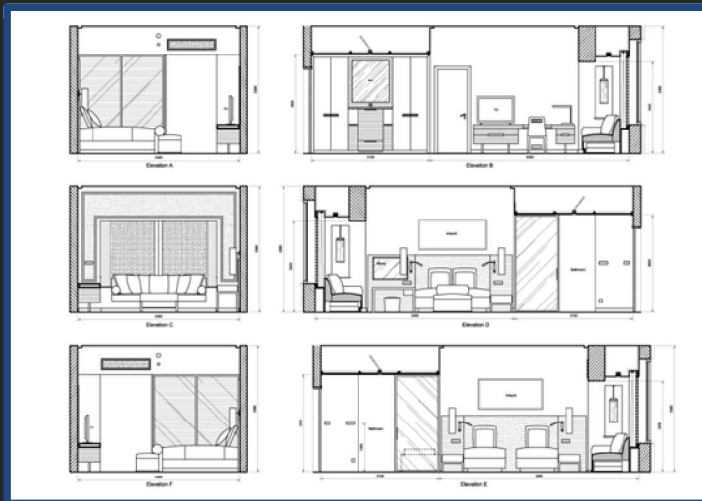



DEFINITION AND RELATIONSHIP OF;

- PAINTING
- DRAWING
- DRAFTING
- SKETCHING



**BASIC
DRAFTING**
a manual for beginning drafters
Van Velsor





PAINTING

Is a form of visual art that uses wet media.

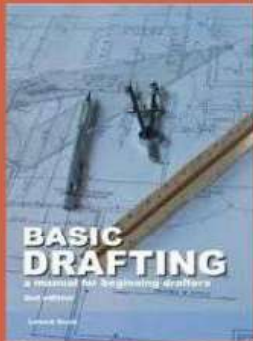

DRAWING

Is a form of visual art that uses dry media. It has two types: Technical and Artistic.

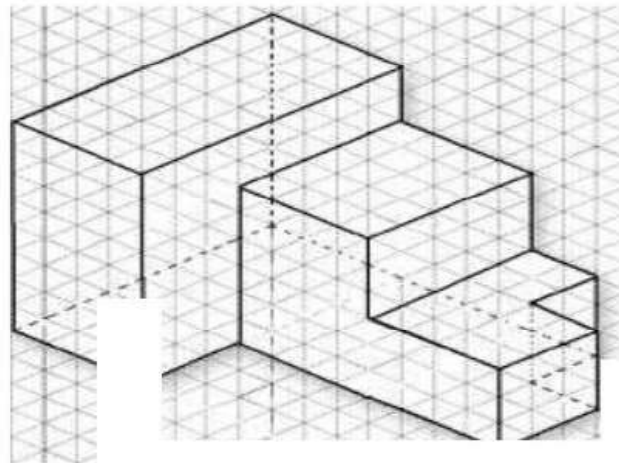
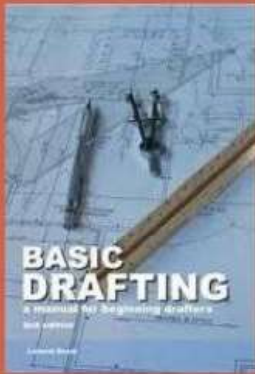

DRAFTING OR TECHNICAL DRAWING

Is the act and discipline of composing plans that visually communicate how something functions or has to be constructed. Drafting is the visual language of industry and engineering. A **drafter**, **draftsperson**, or **draftsman** is a person who makes a technical drawing. A professional drafter who makes technical drawings is sometimes called a **drafting technician**.

Drafting is the term used to refer to the systematic representation and dimensional specification of mechanical and architectural structures.

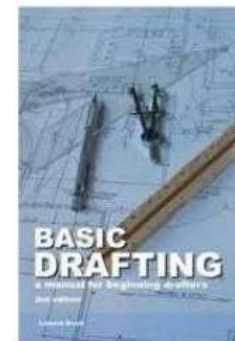



SKETCHING

Is a quickly executed freehand drawing that is not intended as a finished work. In general, sketching is a quick way to record an idea for later use.

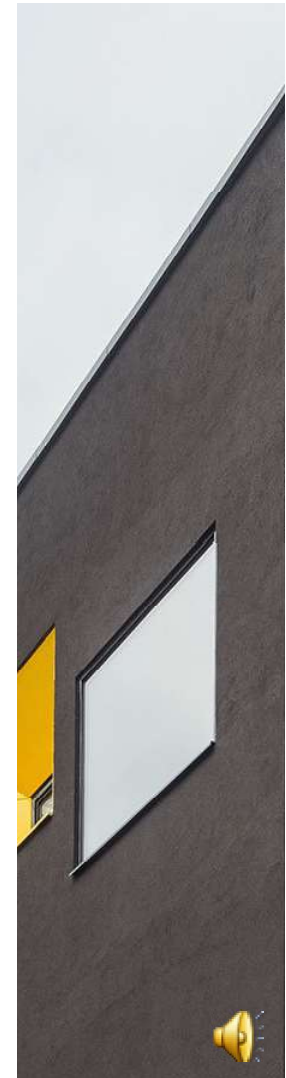
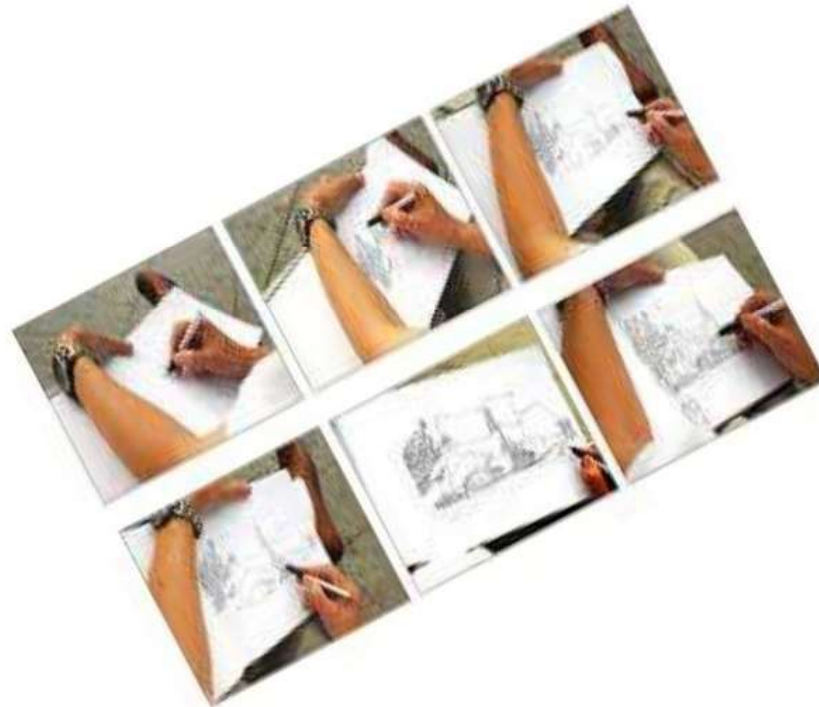
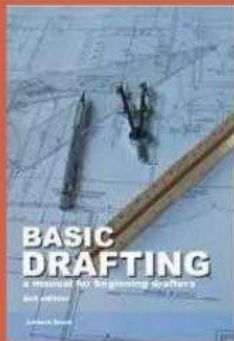

TOOLS NEEDED FOR DRAWING

- DRAWING BOARD/TABLE
- DRAWING PAPER/ PLASTIC FILMS
- TECHNICAL PEN
- MECHANICAL PENCIL
- PARALLEL BAR, T-SQUARE, AND DRAFTING MACHINES
- ERASER
- COMPASS
- TRIANGLES (45x45 AND 30x60)
- SCALES
- PROTRACTOR



DRAWING BOARD/TABLE

- To produce quality drawings for interior design projects, it is necessary to establish a dedicated workplace.
- Designs can be drawn manually on a drawing board set on a tabletop surface, on a handmade drafting table, or on a ready-made drafting table.
- Or they can be drawn using computer drafting hardware and software that augments a drawing board or replaces it totally.

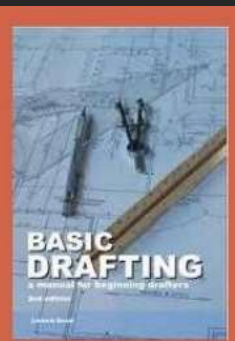

DRAWING PAPERS/PLASTIC FILM

- Drawings can be produced on paper or plastic film.
- The quality of paper or film will help determine the quality of line work.
- A variety of papers and plastic films are manufactured today in many standard sheet sizes and rolls.
- The choice of which to use is dependent upon the designer's overall intent, office standards, and the intended method selected for making a copy from the original.

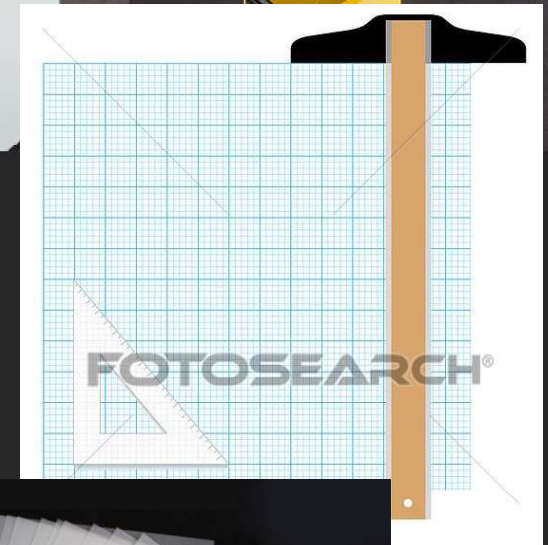
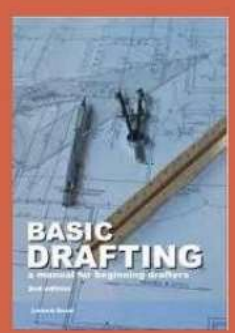

PENCILS, LEADS, AND PENS

- Pencils are one of the most basic and primary drawing tools of the professional designer.
- There are three basic types of pencils available to a designer for producing quality drawings (Figure 2-2).
- The selection is a matter of preference and the particular level of performance needed by the user.

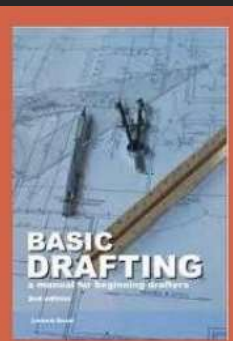
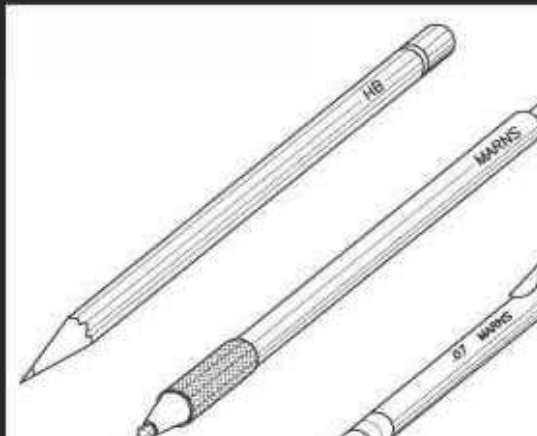

Table 2-2 Pencil-lead Weights*

| | |
|----|---|
| 9H | } Hard pencil leads are used for drawings, light layouts, and drawings requiring a high degree of accuracy. |
| 8H | |
| 7H | |
| 6H | |
| 5H | |
| 4H | |
| 3H | } These leads are used for sketching, architectural line work, lettering and general purposes. |
| 2H | |
| H | |
| F | |
| HB | |
| B | |
| 2B | } Soft leads are used for sketching, rendering, and graphical accents. |
| 3B | |
| 4B | |
| 5B | |
| 6B | |

*The gradations can vary with different brands and types of drawing media. When in doubt, try a sample or test first.



PARALLEL BAR, T-SQUARE, AND DRAFTING MACHINES

- It is extremely important to make sure lines on design drawings and construction drawings are exactly straight and, when required, parallel.
- To make sure lines are straight in a horizontal, vertical, and angular direction, there are several tools available.
- The most common of these instruments are the T-square and parallel bar (Figure 2-4). A device called a drafting machine (Figure 2-5) is also sometimes used.

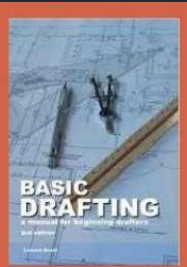

Figure 2-4 The T-square and the parallel bar are used to create straight lines, whether they are horizontal or vertical.

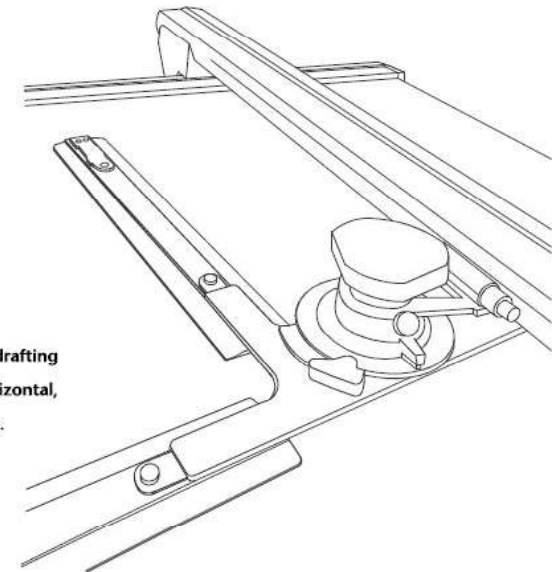
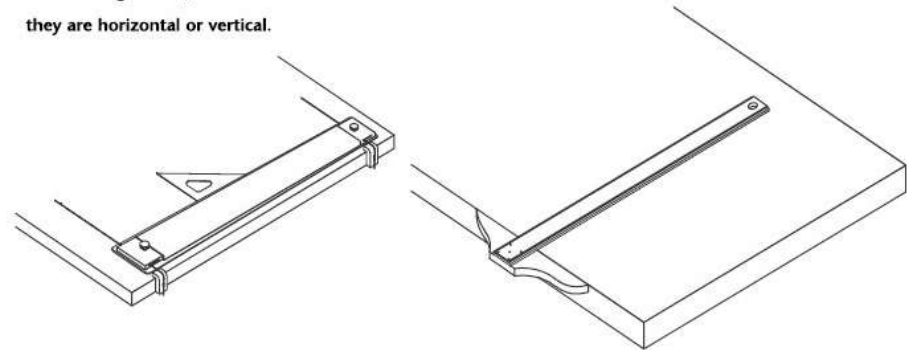

Figure 2-5 An arm-track drafting machine can produce horizontal, vertical, and angular lines.



TRIANGLES, TEMPLATES

- A variety of other drawing tools are available for constructing vertical or inclined lines as well as circles, curvilinear shapes not based on fixed-radius circular forms, and other special shapes such as representations of furniture, plumbing fixtures, and other interior equipment and furnishings. The set squares typically come in two forms – one with 30-60-90 degree angles, and the other 45-45-90 degree angles.

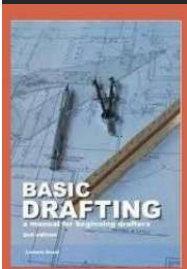

Figure 2-6 Triangles are also used to create straight lines when drawing. When used with a parallel bar or T-square, angular and vertical lines can be drawn. Shown on the left is a fixed 30-60 triangle; on the right is an adjustable triangle.

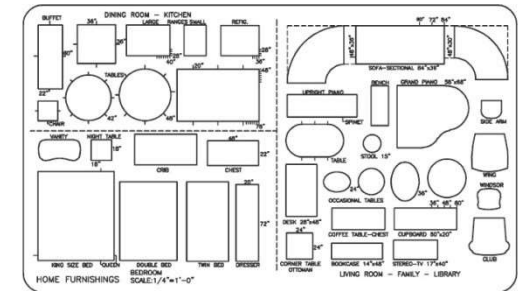
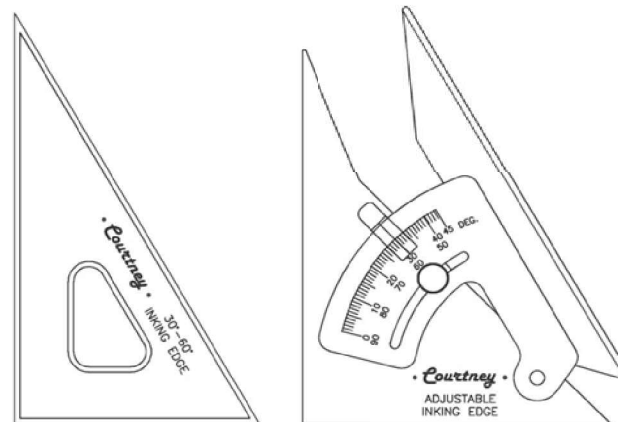
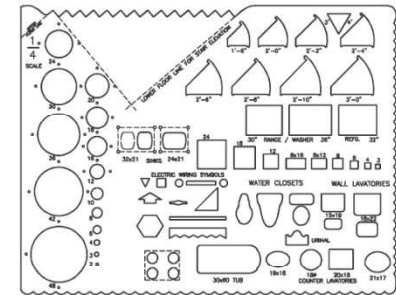

Figure 2-7 Templates are used to speed up the drafting process by tracing the punched shapes directly onto a drawing. Templates come in a variety of patterns and scales.



COMPASS

- A compass is an inverted V-shaped instrument used for drawing circles and arcs (Figure 2-8).
- It has a pin at the end of one leg and a lead holder at the end of the other.
- A special device will allow technical pen points to be used with the compass.

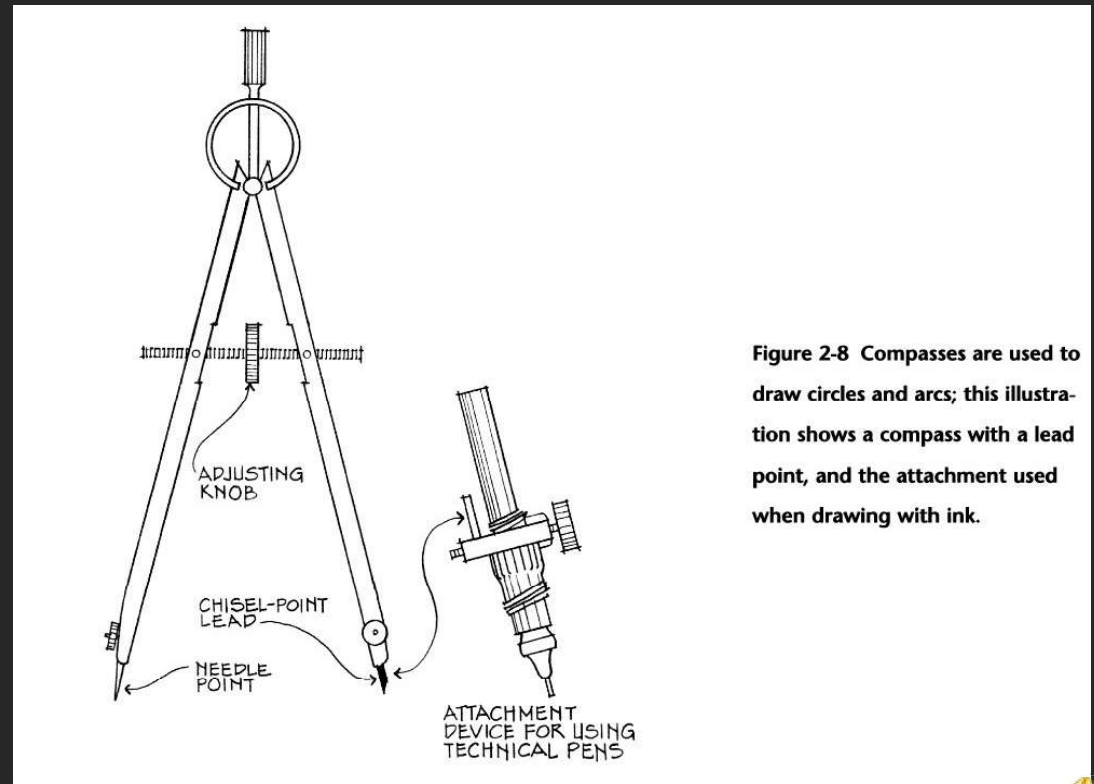
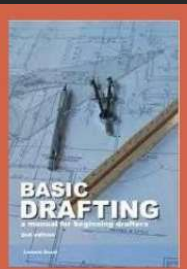

Figure 2-8 Compasses are used to draw circles and arcs; this illustration shows a compass with a lead point, and the attachment used when drawing with ink.



SCALES

- Measuring tools are extremely important to the designer, because a designer's plans, elevations, sections, and details must always be drawn with all their dimensions at the same fractional part of their real (full-size) dimensions.
- This scale of the drawing is always stated on the drawing. When a drawing is drawn to scale, this means that all dimensions on the drawing are related to the real object, or space, by an appropriate selected scale ratio.
- For example, when drawing at a scale of $1/8" = 1'-0"$, each $1/2"$ increment in the drawing represents a foot in the full-size object.

Architect's Scale
Engineer's Scale
Metric Scale

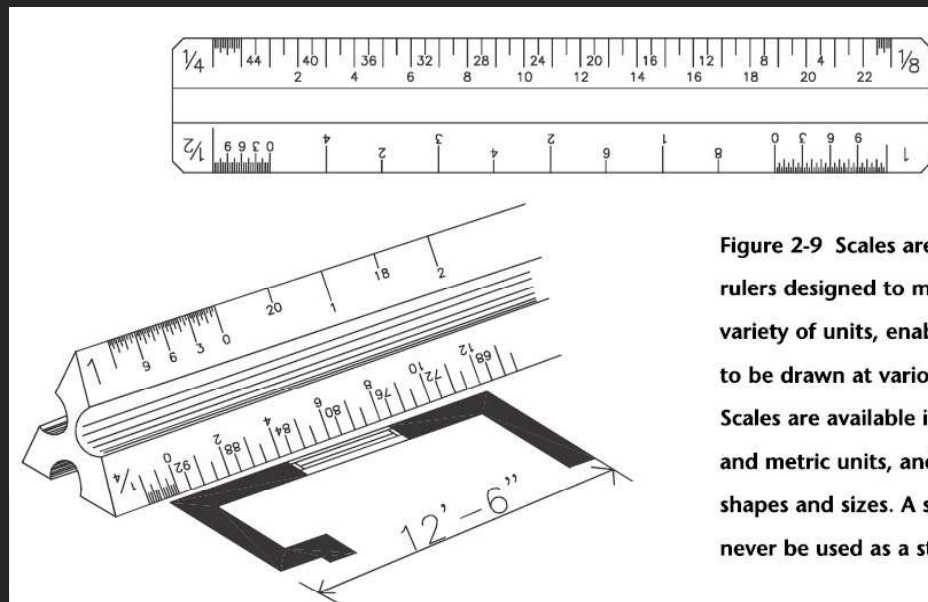
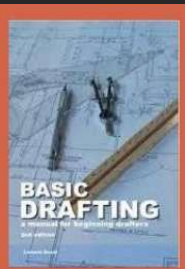

Figure 2-9 Scales are special rulers designed to measure in a variety of units, enabling objects to be drawn at various sizes. Scales are available in English and metric units, and in various shapes and sizes. A scale should never be used as a straightedge.



Erasers, Erasing Shields, and Brushes

- To be able to erase errors and correct drawings is very important to the designer. Erasability is one of the key advantages of using a pencil or pen for drawings. Erasers, erasing shields, and brushes are convenient tools of almost equal importance.

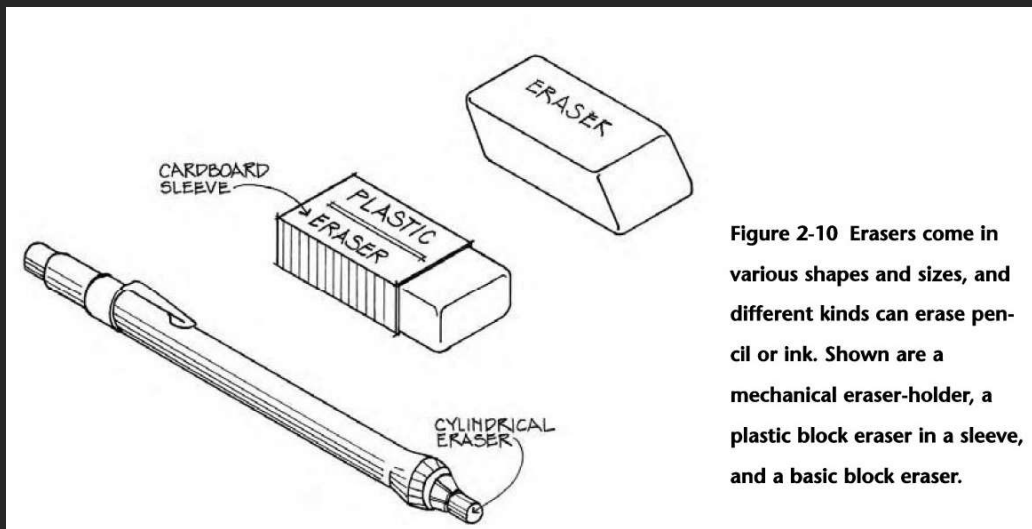

Figure 2-10 Erasers come in various shapes and sizes, and different kinds can erase pencil or ink. Shown are a mechanical eraser-holder, a plastic block eraser in a sleeve, and a basic block eraser.

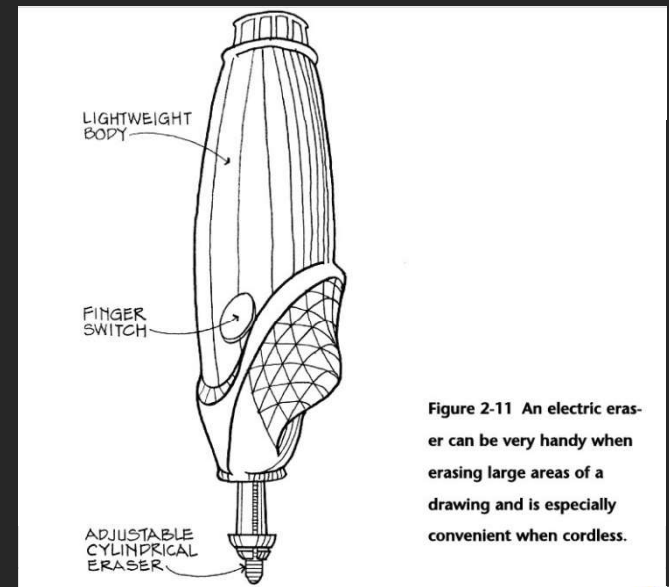

Figure 2-11 An electric eraser can be very handy when erasing large areas of a drawing and is especially convenient when cordless.

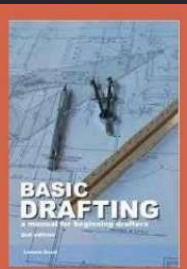

Figure 2-12 An eraser shield allows for precise erasing, as it shields the parts of the drawing that are to remain. The prepunched holes allow the designer to erase only those lines needing to be erased.

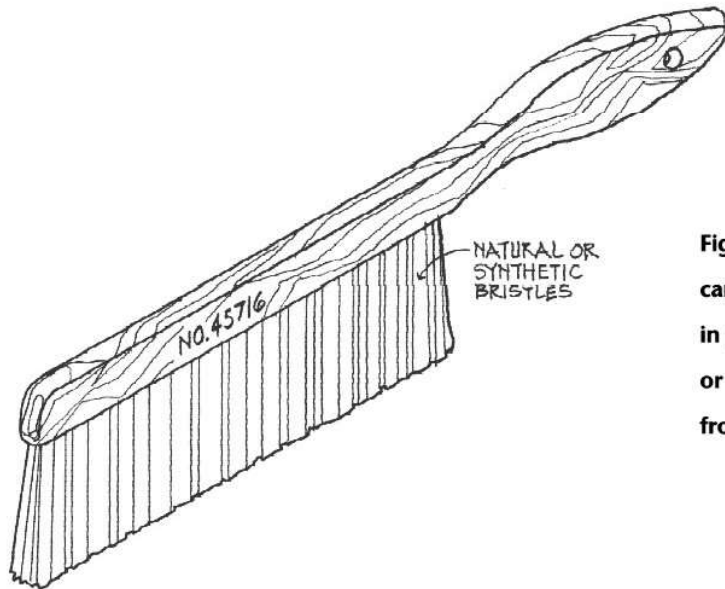
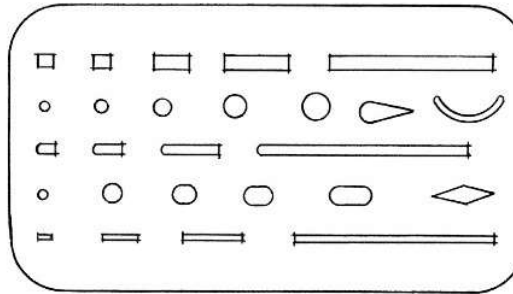

Figure 2-13 Dusting brushes can be used to clean an area in preparation for drawing, or to clean erasure crumbs from a drawing in process.



TITLE BLOCK AND BORDER

The **title block** gives the reader of the **drawing** critical information about the document, including the project name, author, date of issue, topic, its place within a **drawing** series, etc.

It gives all of the project's documents a consistent, professional look.

TITLE BLOCK - Borders, contents, (use title block handout for info), and sheet numbering.

THE TITLE BLOCK AND BORDER

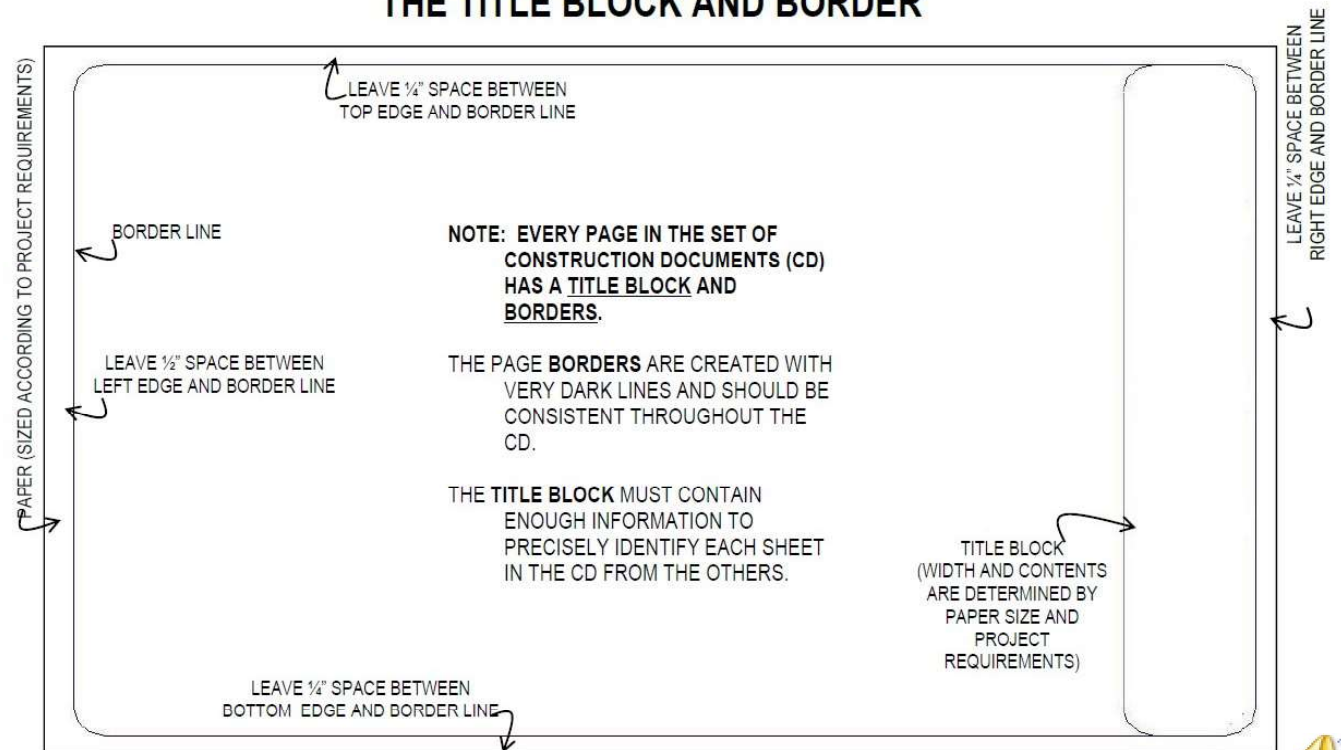

DRAW FREEHAND STRAIGHT LINE

- Drawing A Line is a reflection of your attitude and your personality. The kind of line –direct, clean, clumsy, hesitant, heavy, light, incisive etc- depends on your personality.
- It improves with practice, as you will see with these few warming-up exercise.
- The **importance** of **freehand drawing** for educating architects is often underestimated. ...
- The act of **drawing** shows you how to see and observe. It helps develop spatial imagination.
- A design idea can be quickly and easily clarified and displayed in only a few strokes.

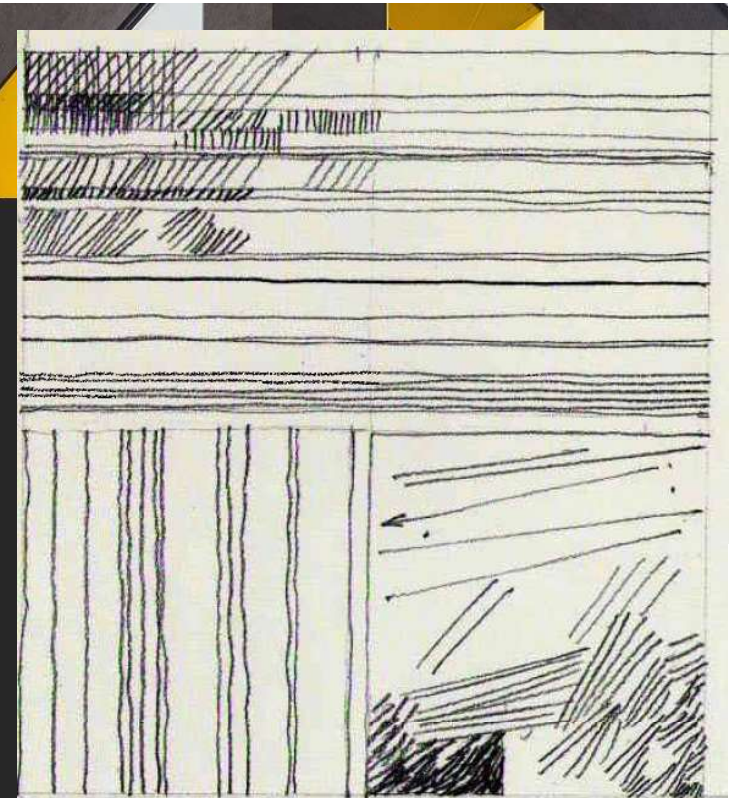
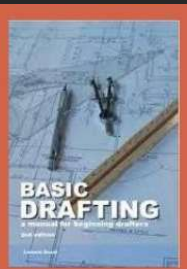

Draw some straight lines from one point to another, without looking at the tip of the pencil too much. Just skim over the paper the first time, as if to register the distance, then draw it the second time.



HOW TO DRAW FREEHAND STRAIGHT LINE

- **Method...**

1. use a loose, 4-finger grip
 2. use the least # of muscles as possible (no fingers, use the arm to draw the line)
 3. maintain a constant and fairly fast-paced speed
 4. before drawing the line, draw a practice line between 2 pre-set start and end points
 5. find comfortable positioning to make use of the length of the arm
- * * * * for horizon lines: let hand run along horizontal edge of page, adjust length of grip to allow for this.

Never move the fingers, always the arm.

Following these steps will produce a straight line.

Links

- 1) <https://www.youtube.com/watch?v=WJkkpN7TZt0>
- 2) <https://www.youtube.com/watch?v=EY2F-SWFhAs>

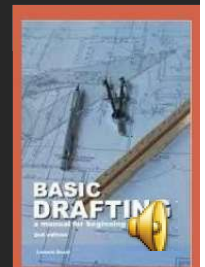

THANKS

