

Lab # 4

Modeling Of Transfer Function Using SIMULINK

Objective:

SIMULINK Tutorial

SIMULINK is the Graphical User Interface (GUI) for MATLAB. This section presents a brief tutorial on how to use SIMULINK to create an open-loop block diagram.

1. Simulink is started from the MATLAB command prompt by entering the following command: simulink
2. Alternatively, you can hit the Simulink button at the top of the MATLAB window as shown here:

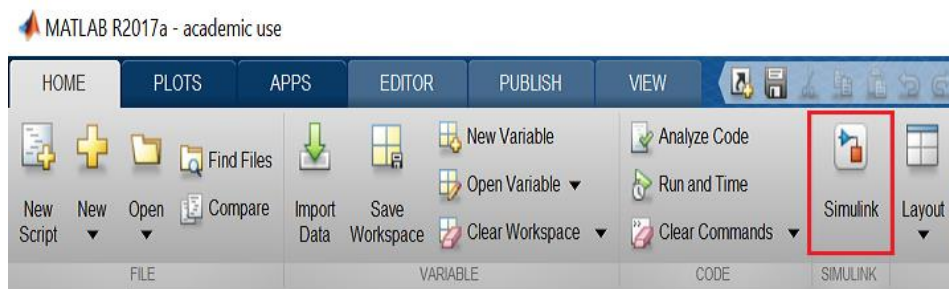

When it starts, Simulink brings up a single window, entitled **Simulink Start Page** which can be seen here.

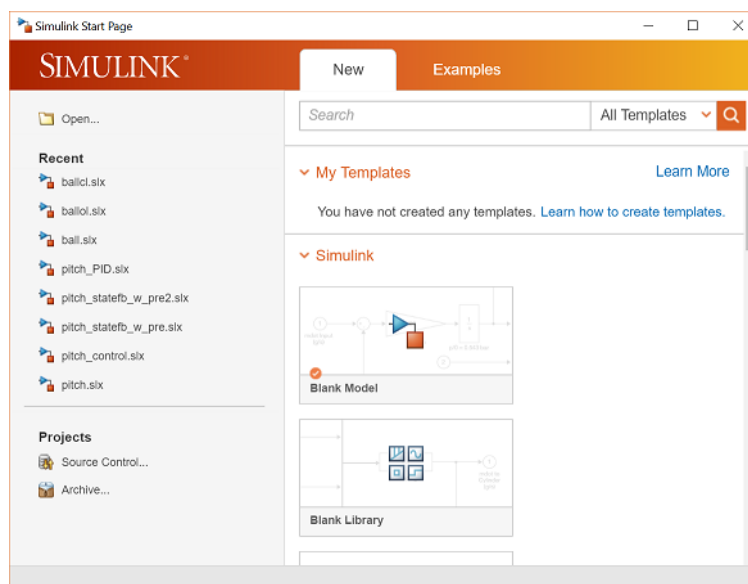

Once you click on **Blank Model**, a new window will appear as shown below.

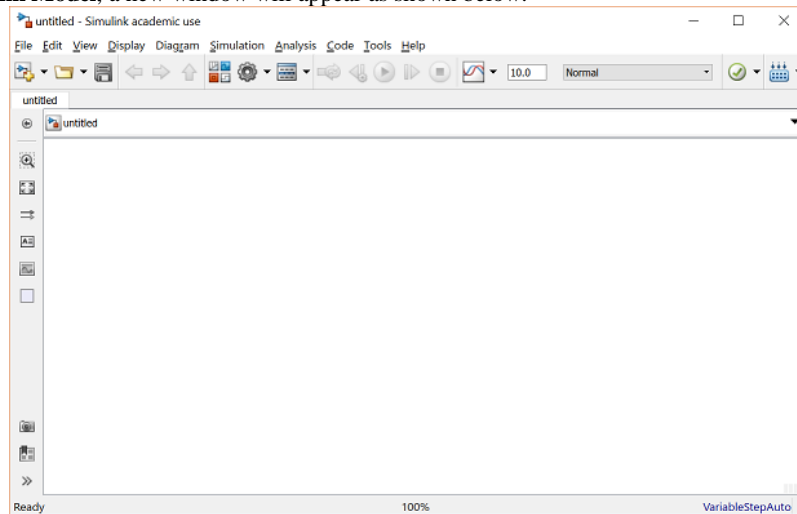

Model Files

In Simulink, a model is a collection of blocks which, in general, represents a system. In addition to creating a model from scratch, previously saved model files can be loaded either from the **File** menu or from the MATLAB command prompt.

A new model can be created by selecting **New** from the **File** menu in any Simulink window (or by hitting **Ctrl-N**).

Basic Elements

There are two major classes of items in Simulink: **blocks** and **lines**. Blocks are used to generate, modify, combine, output, and display signals. Lines are used to transfer signals from one block to another.

Blocks

There are several general classes of blocks within the Simulink library:

- **Sources:** used to generate various signals
- **Sinks:** used to output or display signals
- **Continuous:** continuous-time system elements (transfer functions, state-space models, PID controllers, etc.)
- **Discrete:** linear, discrete-time system elements (discrete transfer functions, discrete state-space models, etc.)
- **Math Operations:** contains many common math operations (gain, sum, product, absolute value, etc.)
- **Ports & Subsystems:** contains useful blocks to build a system

Blocks have zero to several input terminals and zero to several output terminals. Unused input terminals are indicated by a small open triangle. Unused output terminals are indicated by a small triangular point. The block shown below has an unused input terminal on the left and an unused output terminal on the right.

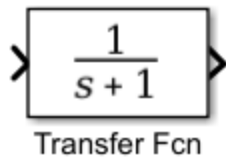

Lines

Lines transmit signals in the direction indicated by the arrow. Lines must always transmit signals from the output terminal of one block to the input terminal of another block. On exception to this is a line can tap off of another line, splitting the signal to each of two destination blocks.

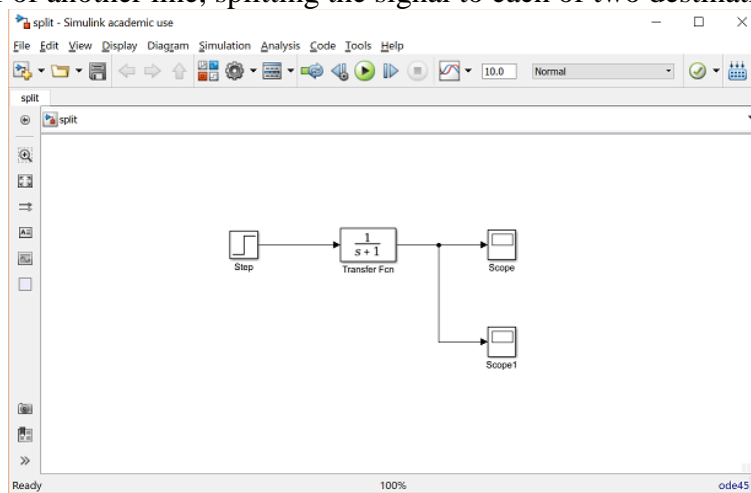

Simple Example

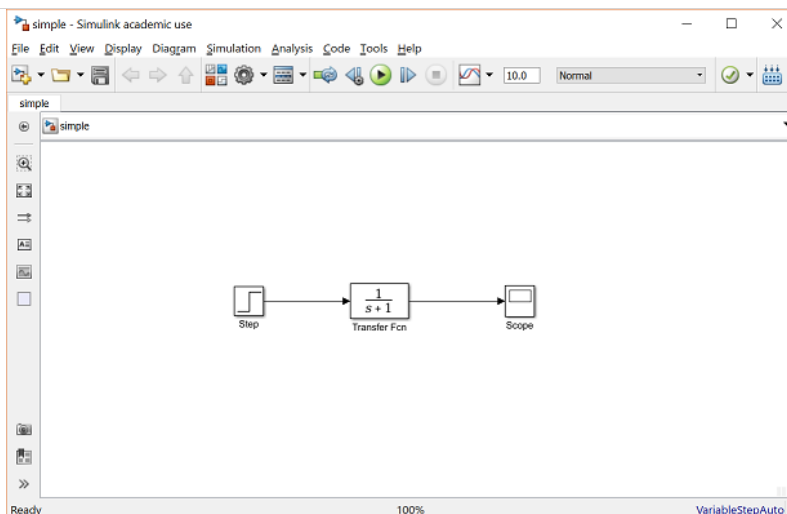

The simple model consists of three blocks: Step, Transfer Function, and Scope.

- The Step is a **Source** block from which a step input signal originates.
- This signal is transferred through the **line** in the direction indicated by the arrow to the *Transfer Function Continuous* block.
- The *Transfer Function* block modifies its input signal and outputs a new signal on a line to the *Scope*.
- The *Scope* is a **Sink** block used to display a signal much like an oscilloscope.

There are many more types of blocks available in Simulink,

Modifying Blocks

A block can be modified by double-clicking on it. For example, if you double-click on the *Transfer Function* block in the Simple model, you will see the following dialog box.

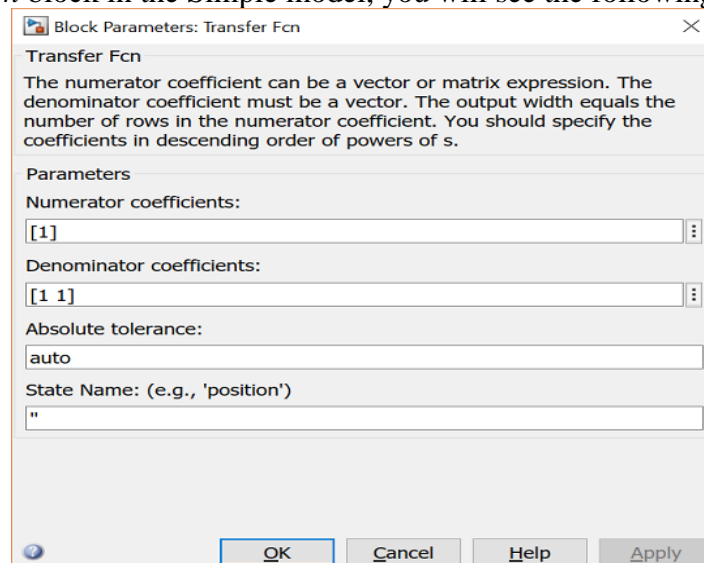

This dialog box contains fields for the numerator and the denominator of the block's transfer function. By entering a vector containing the coefficients of the desired numerator or denominator polynomial, the desired transfer function can be entered. For example, to change the denominator to

$$(1)s^2 + 2s + 4$$

Enter the following into the denominator field

[1 2 4]

and hit the close button, the model window will change to the following,

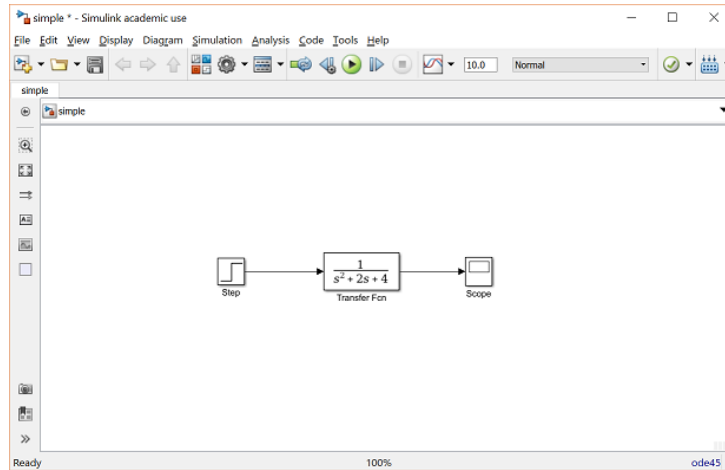

which reflects the change in the denominator of the transfer function.

The *Step* block can also be double-clicked, bringing up the following dialog box.

The default parameters in this dialog box generate a step function occurring at time = 1 sec, from an initial level of zero to a level of 1 (in other words, a unit step at $t = 1$). Each of these parameters can be changed. Close this dialog before continuing.

The most complicated of these three blocks in the *Scope* block. Double-clicking on this brings up a blank oscilloscope screen.

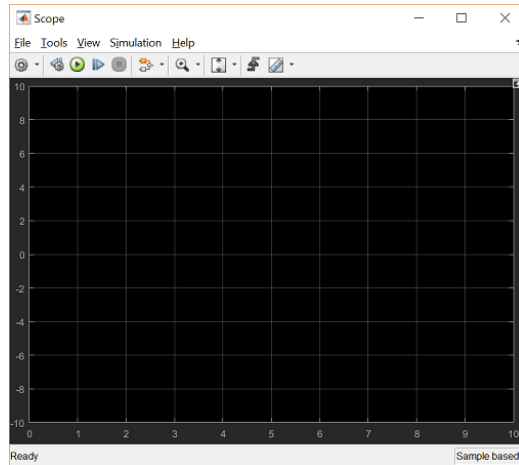

When a simulation is performed, the signal which feeds into the scope will be displayed in this window. Then, to start the simulation, either select **Run** from the **Simulation** menu, click the **Play** button at the top of the screen, or hit **Ctrl-T**.

The simulation should run very quickly and the scope window will appear as shown below.

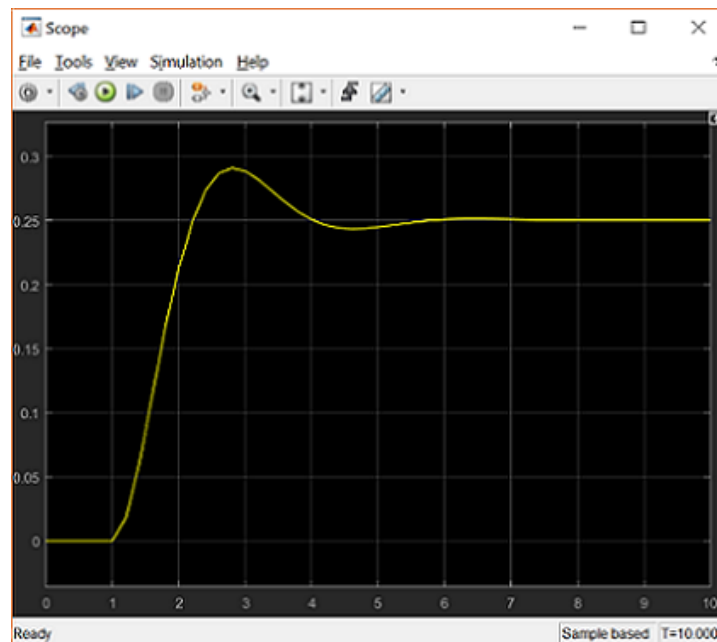

Note that the step response does not begin until $t = 1$. This can be changed by double-clicking on the *step* block. Now, we will change the parameters of the system and simulate the system again. Double-click on the *Transfer Function* block in the model window and change the denominator to:

[1 20 400]

Re-run the simulation (hit **Ctrl-T**) and you should see the following in the scope window.

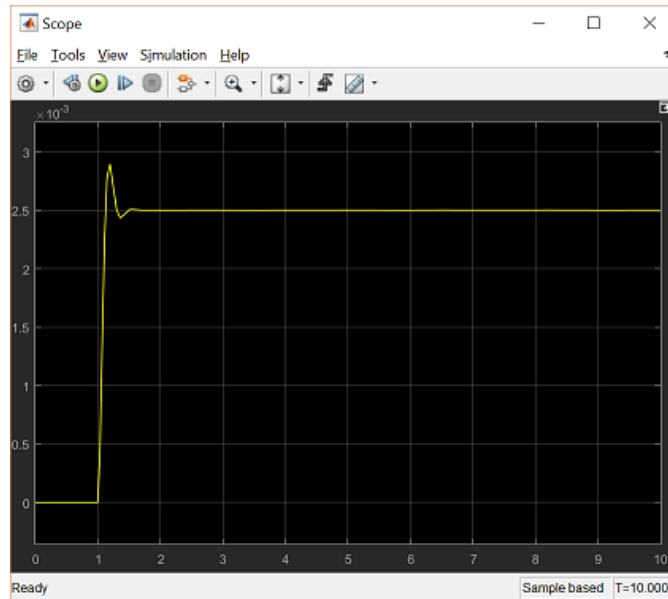

Since the new transfer function has a very fast response, it compressed into a very narrow part of the scope window. This is not really a problem with the scope, but with the simulation itself. Simulink simulated the system for a full ten seconds even though the system had reached steady state shortly after one second.

To correct this, you need to change the parameters of the simulation itself. In the model window, select **Model Configuration Parameters** from the **Simulation** menu. You will see the following dialog box.

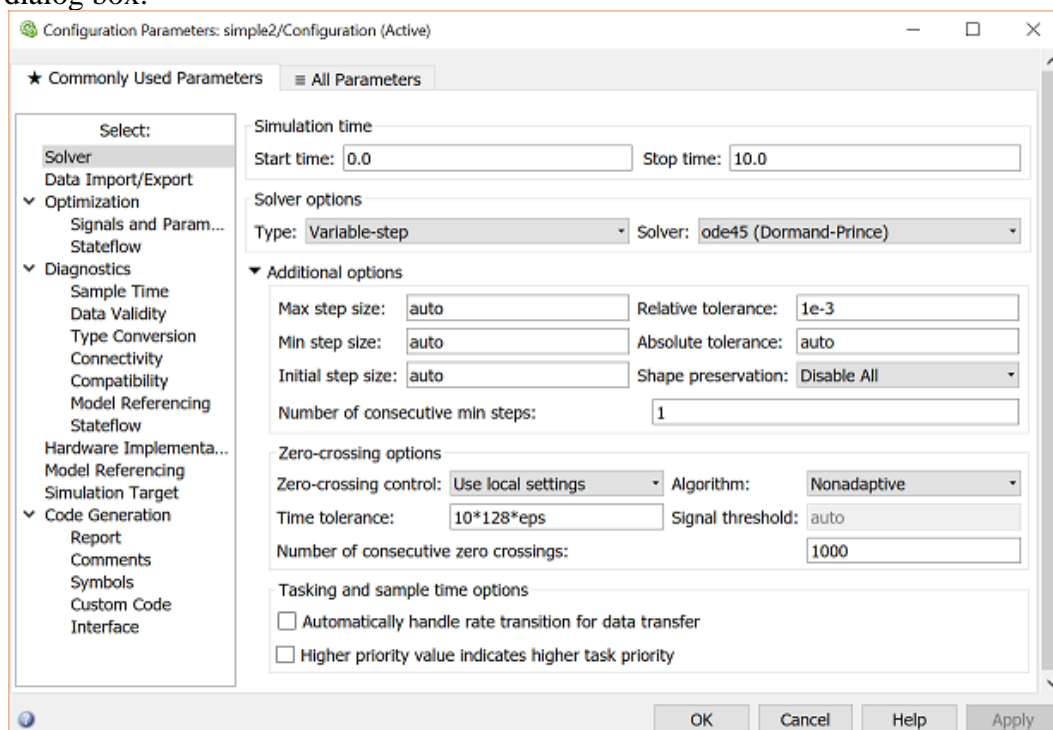

There are many simulation parameter options; we will only be concerned with the start and stop times, which tell Simulink over what time period to perform the simulation. Change **Start time** from 0.0 to 0.8 (since the step doesn't occur until $t = 1.0$).

Change **Stop time** from 10.0 to 2.0, which should be only shortly after the system settles. Close the dialog box and rerun the simulation. Now, the scope window should provide a much better display of the step response as shown below.

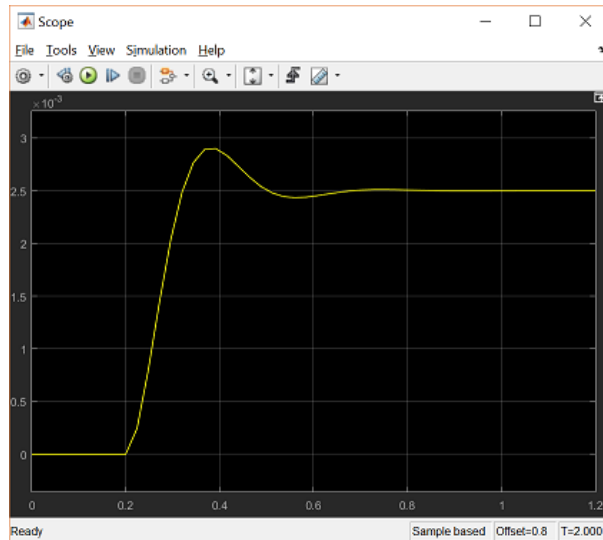

Post Lab Questions

a) What is Simulink?

b) How do we access SIMULINK library?

c) What are blocks and lines?

d) What is source and sink used for?

Lab Tasks

Task 1

Generate the following MATLAB SIMULINK model and simulate its step response.

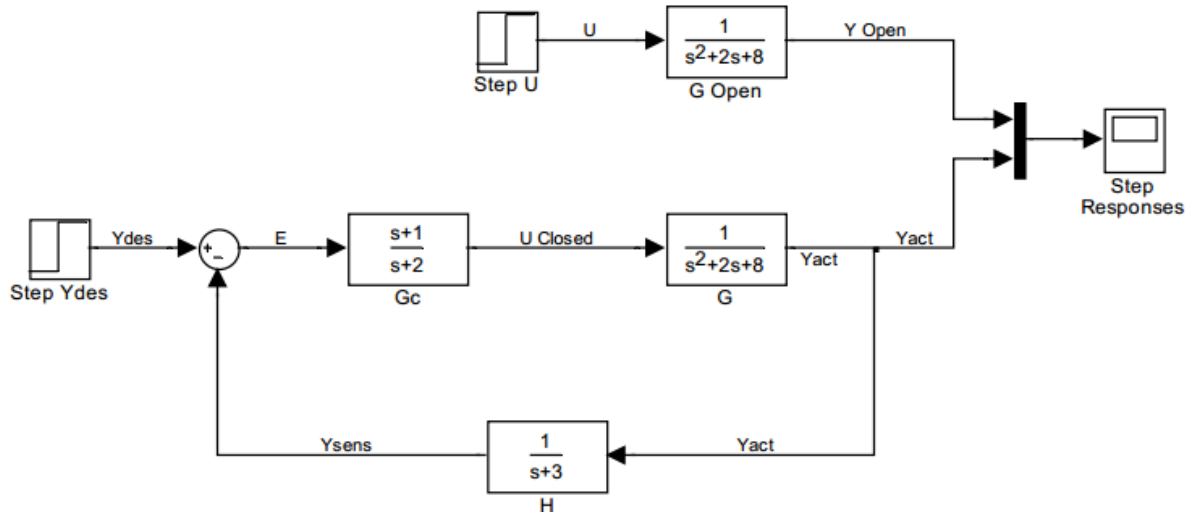

Task 2

a. Obtain the unit impulse response of the following system using SIMULINK.

$$\frac{B(s)}{A(s)} = \frac{1}{s^2 + 0.2s + 1}$$

b. Obtain the unit step response of the following system using SIMULINK.

$$\frac{B(s)}{A(s)} = \frac{s}{s^2 + 0.2s + 1}$$

Explain why the results in a and b are same.

Task 3

Create a SIMULINK model with with gain, $K = 1$, and time constant, $T = 0.1$ sec. The sample time is -1 sec. Experiment with different values of K and observe how the system response changes. Plot the results.

