



NAME: AMIT SINGH

ID: 15478

SUBJECT: DIGITAL LOGIC DESIGN

SEMESTER: 3RD

PROGRAMME: BS (SOFTWARE ENGINEERING)

FULL SUBTRACTOR

AIM: Design and verify the logic circuit of Full subtractor using of Half subtractor.

OBJECTIVES: • To understand the principle of binary subtraction. • To understand full subtractor concept. • Use truth table and Boolean Algebra theorems in simplifying a circuit design. • To implement full subtractor circuit of Half subtractor

PROCEDURE: • Collect the components necessary to accomplish this experiment. • Plug the IC chip into the breadboard. • Connect the supply voltage and ground lines to the chips. PIN7 = Ground and PIN14 = +5V. • According to the pin diagram of each IC mentioned above, make the connections according to circuit diagram. • Connect the inputs of the gate to the input switches of the LED. • Connect the output of the gate to the output LEDs. • Once all connections have been done, turn on the power switch of the bread-board • Operate the switches and fill in the truth table (Write "1" if LED is ON and "0" if LED is OFF Apply the various combination of inputs according to the truth table and observe the condition of Output LEDs.

FULL SUBTRACTOR: A full Subtractor is combinational circuit that performs a subtraction between three bits, considering that a $\tilde{A}Y1\tilde{A}Z$ may have been borrowed by lower significant stage. The 3 inputs denote minuend, subtrahend and previous borrow, respectively. The 2 outputs are difference(D) and borrow(B)

A	B	B _{IN}	D	B _{OUT}
0	0	0	0	0
0	0	1	1	1
0	1	0	1	1
0	1	1	0	1
1	0	0	1	0
1	0	1	0	0
1	1	0	0	0

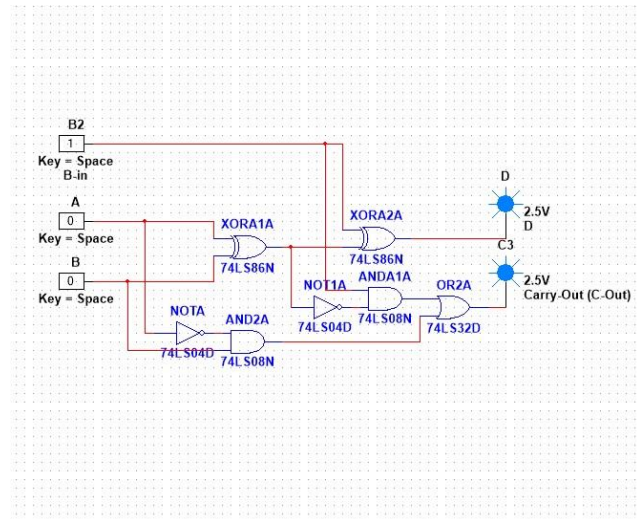
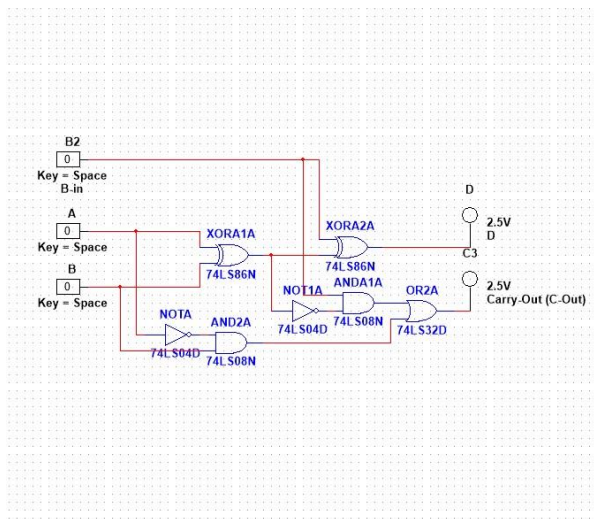

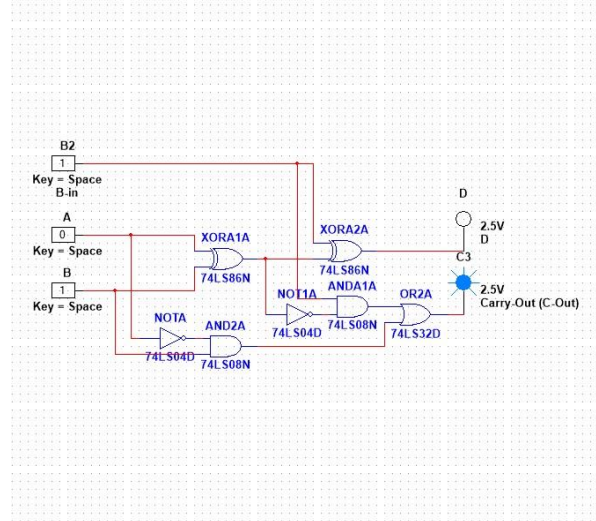
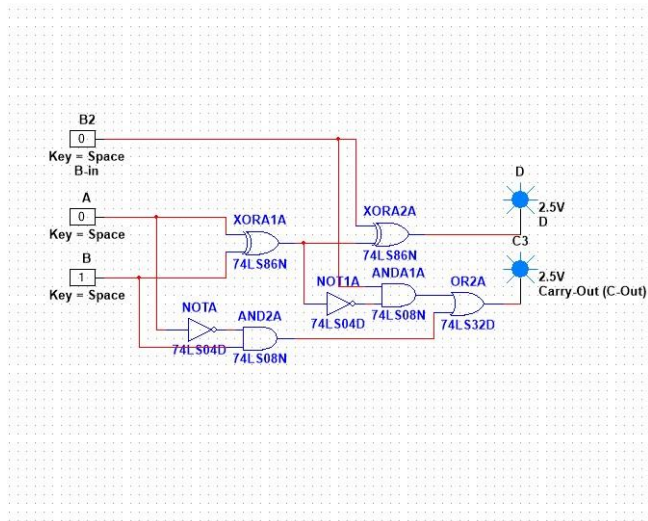

RESULTS AND ANALYSIS: Verified the truth table as follows
 Verified the truth table of Full Subtractor as $D = 1$ i.e. LED which is connected to D terminal glows when inputs are, Y, BIN
 Verified the truth table of Full Subtractor as $BOUT = 1$ i.e. LED which is connected to BOUT terminal glows when inputs are X, Y, BIN

CONCLUSION: • To add two bits, we require one XOR gate (IC 7486) to generate Difference and one AND (IC 7408) and NOT Gate (IC 7432) to generate Borrow. • To add three bits, we require two half subtractor