

Half Subtractor

Sir. Muhammad Amin

Name = Farhan Akhtar

iD # 15554

LAB# 4

HALF SUBTRACTOR

AIM:

Design and verify the logic circuit of Half-subtractor using logic gate.

OBJECTIVES:

- To understand the principle of binary subtraction.
- To understand half-subtractor concept.
- Use truth table and Boolean Algebra theorems in simplifying a circuit design.
- **To implement half-subtractor circuit using logic gates**

PROCEDURE:

- Collect the components necessary to accomplish this experiment.
- Plug the IC chip into the breadboard.
- Connect the supply voltage and ground lines to the chips. PIN7 = Ground and PIN14 = +5V.
- According to the pin diagram of each IC mentioned above, make the connections according to circuit diagram.
- Connect the inputs of the gate to the input switches of the LED.
- Connect the output of the gate to the output LEDs.
- Once all connections have been done, turn on the power switch of the bread-board
- Operate the switches and fill in the truth table (Write "1" if LED is ON and "0" if LED is OFF Apply the various combination of inputs according to the truth table and observe the condition of Output LEDs.

HALF SUBTRACTOR:

The half-subtractor is a combinational circuit which is used to perform subtraction of two bits. It has two inputs, X (minuend) and Y (subtrahend) and two outputs D (difference) and B (borrow).

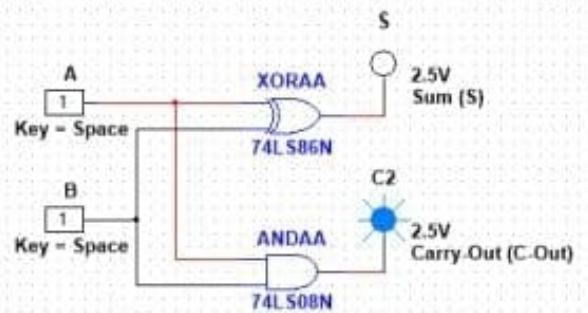
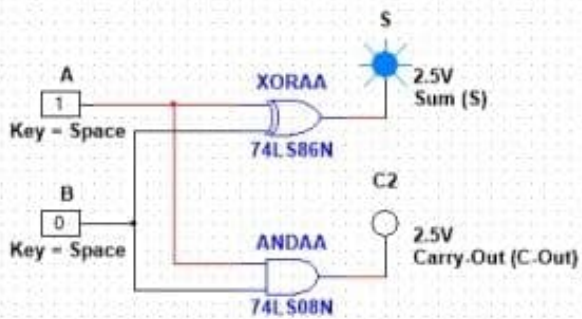
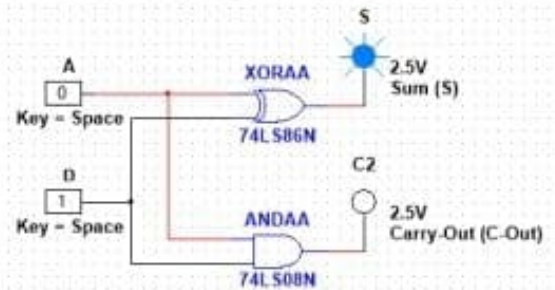
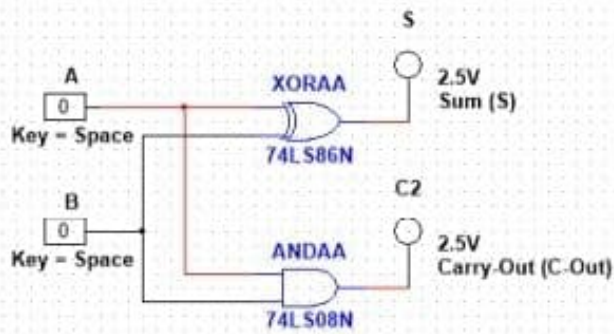

OBSERVATION TABLE:

A	B	D	B _o
0	0	0	0
0	1	1	1
1	0	1	0
1	1	0	0

RESULTS AND ANALYSIS:

Verified the truth table as follows.

Verified the truth table of Full Subtractor as $D = 1$ i.e. LED which is connected to D terminal glows when inputs are, Y, BIN Verified the truth table of Full Subtractor as $BOUT = 1$ i.e. LED which is connected to BOUT terminal glows when inputs are X, Y, BIN

CONCLUSION:

- $> >$ To add two bits, we require one XOR gate (IC 7486) to generate Difference and one AND (IC 7408) and NOT Gate (IC 7432) to generate Borrow.
- $> >$ To add three bits, we require two half subtractor.