



DIGITAL LOGIC DESIGN

De-Multiplexer
Sir. Muhammad Amin
LAB# 7



HASSAN MEHDI

LAB# 7
Csc-201

DE-MULTIPLEXER

AIM:

To the Truth Table of 1:4 De-multiplexer using IC 74139

OBJECTIVES:

- To get familiar with the concept of de-multiplexing

PROCEDURE:

- Collect the components necessary to accomplish this experiment.
- Plug the IC chip into the breadboard.
- Connect the supply voltage and ground lines to the chips. PIN7 = Ground and PIN14 = +5V.
- Make connections as shown in the respective circuit diagram.
- Connect the inputs of the gate to the input switches of the LED.
- Connect the output of the gate to the output LEDs.
- Once all connections have been done, turn on the power switch of the bread-board
- Operate the switches and fill in the truth table (Write "1" if LED is ON and "0" if L1 is OFF Apply the various combination of inputs according to the truth table and observe the condition of Output LEDs.

DE-MULTIPLEXER:

The data distributor, known more commonly as a Demultiplexer or "Demux", is the exact opposite of the Multiplexer. The demultiplexer takes one single input data line and then switches it to any one of several individual output lines one at a time. The demultiplexer converts a serial data signal at the input to a parallel data at its output lines. The Boolean expression for this 1-to-4 Demultiplexer above with inputs I_0 to I_3 and data select lines S_0, S_1 is given as.

$$Y = S_0 S_1 D_0 + S_0 S_1 D_1 + S_0 S_1 D_2 + S_0 S_1 D_3$$

OBSERVATION TABLE:

S ₁	S ₂	DATA	Y ₀	Y ₁	Y ₂	Y ₃
0	0	0	0	0	0	0
0	0	1	1	0	0	0
0	1	0	0	0	0	0
0	1	1	0	0	1	0
1	0	0	0	0	0	0
1	0	1	0	1	0	1
1	1	0	0	0	0	0
1	1	1	0	0	0	0

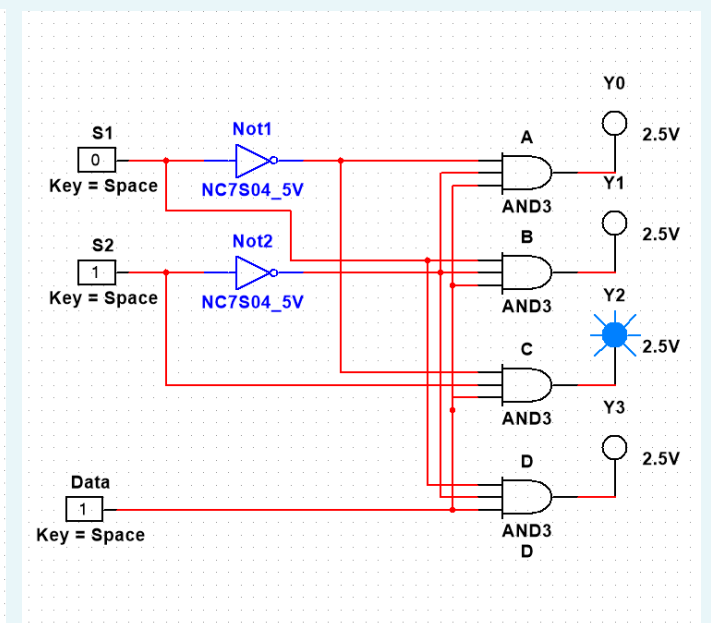
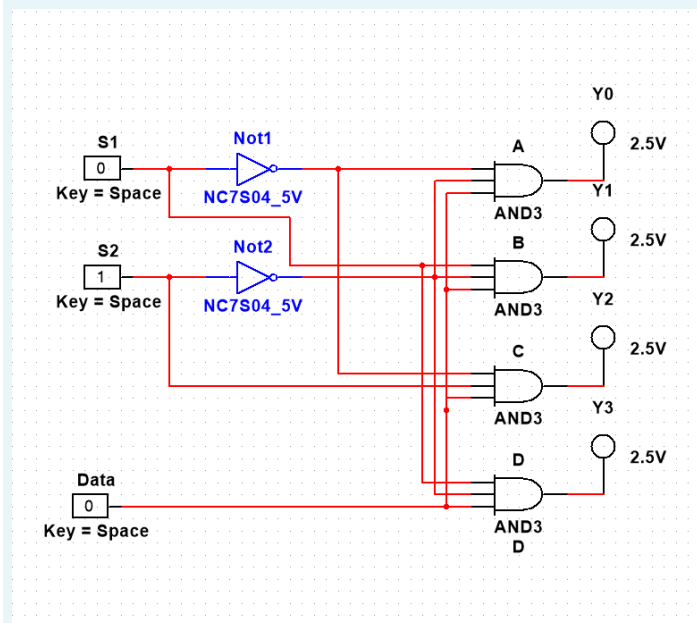
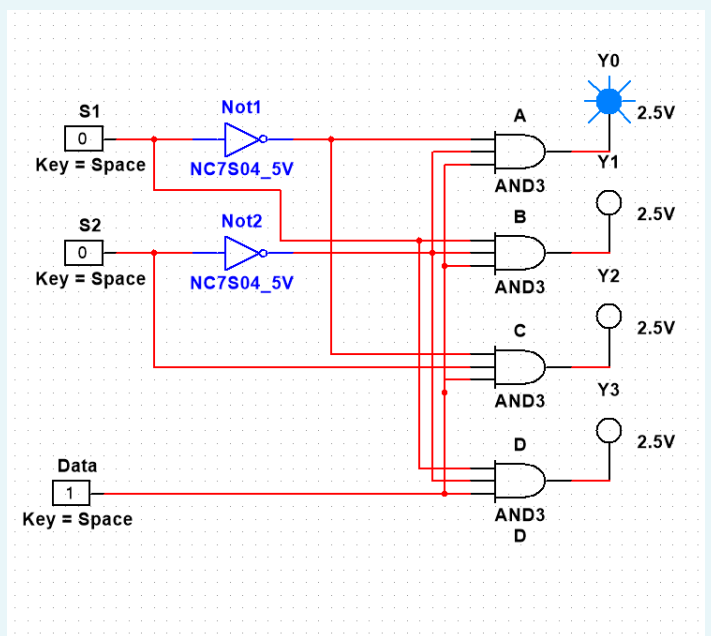
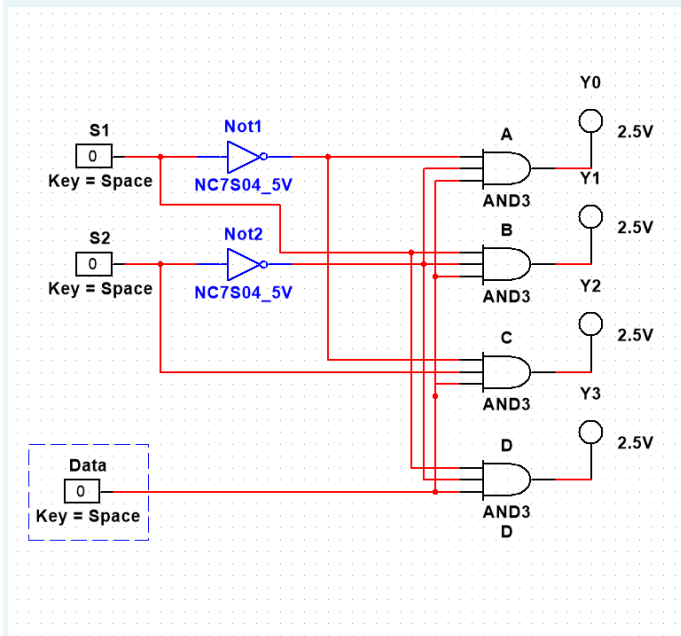

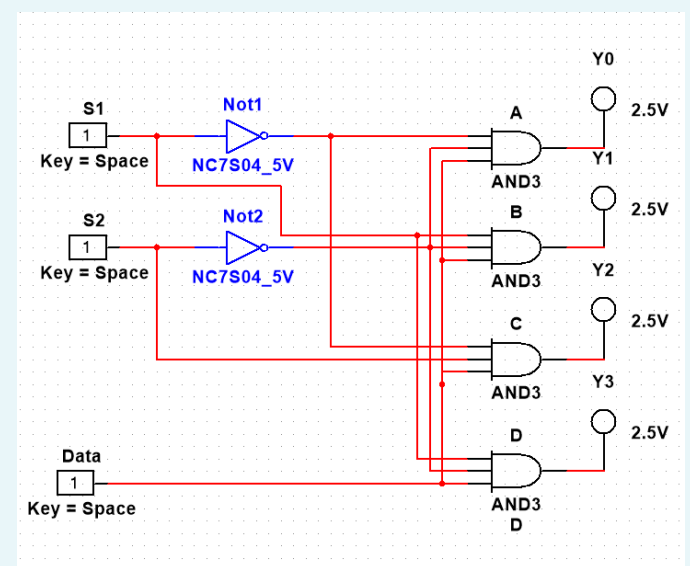
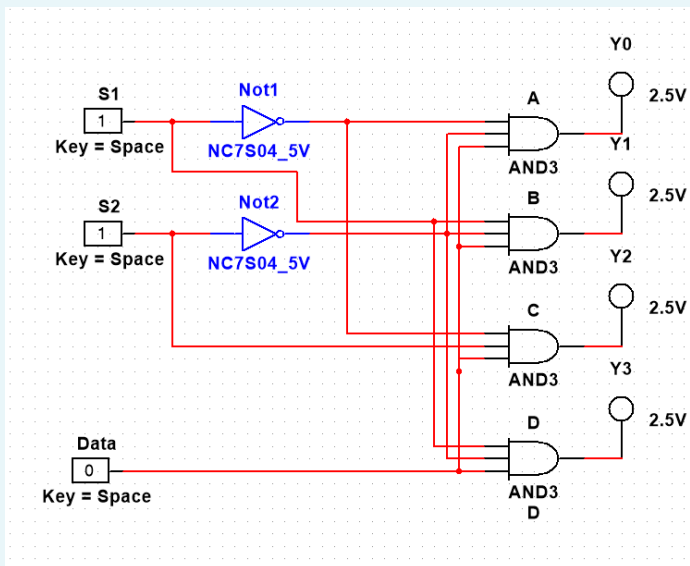
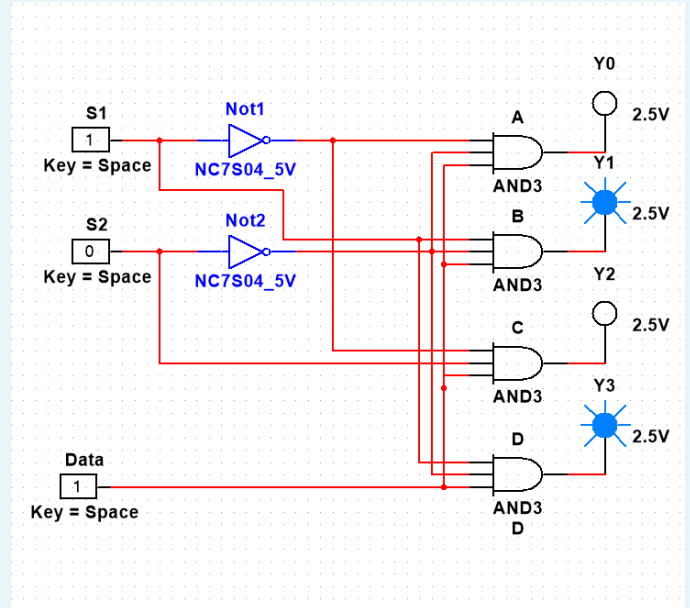
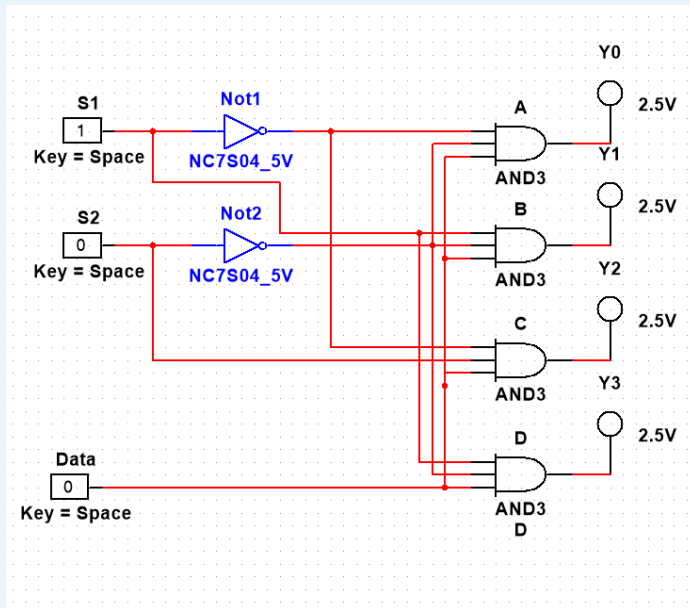

RESULTS AND ANALYSIS:

Multiplexer and demultiplexer help in reducing the cost of transmission of digital signals. Logic design is simple and Boolean expression need not be simplified.

Mux and Demux acts as rotary switches. Multiplexers are used as one method of reducing the number of logic gates required in a circuit or when a single data line is required to carry two or more different digital signals i.e. it converts parallel data into serial data and used for data selection. The demultiplexer converts a serial data signal at the input to a parallel data at its output lines and used for data distribution. Both are available as ICs.

CONCLUSION:

1:4 DEMUX using IC74139 has been verified.