

ID :17008

NAME : SAMIULLAH

JUNE , 25 , 2020

Submitted by : DR.ATIF ISHTIAQ

**Q1) What are the relation between hardware and software.
And types of software with Logical system architecture.**

Answer:

Relationship Between Hardware and Software

Essentially, computer software controls computer hardware. These two components are complementary and cannot act independently of one another. In order for a computer to effectively manipulate data and produce useful output, its

hardware and software must work together. Without software, computer hardware is useless. Conversely, computer software cannot be used without supporting hardware. Similarly, computer software has to first be loaded into the computer's hardware and then executed. There are several categories of software, with the two main categories being operating-system software, which makes the hardware usable, and application software, which does something useful. Examples of operating systems include Microsoft Windows on a personal computer and Google's Android on a mobile phone. Examples of application software are Microsoft Excel and Angry Birds.

Consider the following analogy: an iPod is used to play recorded music in the form of an MP3. In order to listen to the recorded music, you need three things: an iPod, a speaker, and the MP3 file. In this analogy, both the iPod and the speaker are examples of hardware. The MP3 file, in this case, would represent software. Without the iPod or the speaker, you would not be able to listen to the MP3. By the same token, the iPod and the speaker would be worthless without the MP3 files to play.

Information systems such as geographic information systems, search engines, and data warehouses rely on both hardware and software working in concert to achieve the goal of data manipulation. Computer software drives computer hardware by providing the instructions that tell the hardware what to do. Hardware will not function without software and software will not run without the appropriate hardware.

Types of software:

There are two main types of software: systems software and application software. Systems software includes the programs that are dedicated to managing the computer itself, such as the operating system, file management utilities, and disk operating system (or DOS).

- **System software**

System software aids the user and the hardware to function and interact with each other. Basically, it is a software to manage computer hardware behavior so as to provide basic functionalities that are required by the user. In simple words, we can say that system software is an intermediary or a middle layer between the user and

the hardware. These computer software sanction a platform or environment for the other software to work in. This is the reason why system software is very important in managing the entire computer system. When you first turn on the computer, it is the system software that gets initialized and gets loaded in the memory of the system. The system software runs in the background and is not used by the end-users. This is the reason why system software is also known as 'low-level software'.

- **Application software**

Application Software, also known as end-user programs or productivity programs are software that helps the user in completing tasks such as doing online research, jotting down notes, setting an alarm, designing graphics, keeping an account log, doing calculations or even playing games. They lie above the system software. Unlike system software, they are used by the end-user and are specific in their functionality or tasks and do the job that they are designed to do. For example, a browser is an application designed specifically for browsing the internet or MS Powerpoint is an application used specifically for making presentations

System architecture

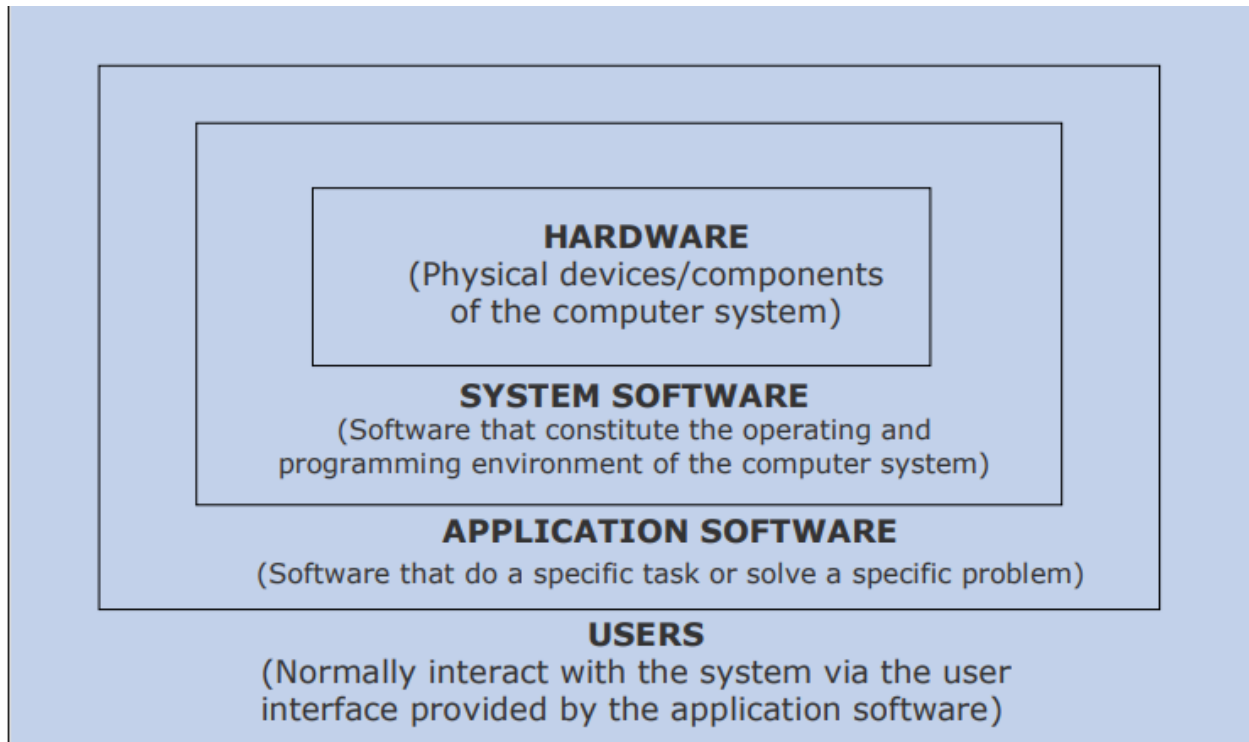

Relationship among hardware, system software, application software, and users of a computer system

Several types of systems architectures are as follows:

- Hardware architecture
- Software architecture
- Enterprise architecture
- Collaborative systems architectures (such as the Internet, intelligent transportation systems, and joint air defense systems)
- Manufacturing systems architectures
- Strategic systems architecture

Q 2) Write a note on Multimedia and its type with common media for storage access and transmission in details.

Answer:

MULTIMEDIA:

Media is something that can be used for presentation of information.

- Two basic ways to present some information are:
- Unimedia presentation: Single media is used to present information
- Multimedia presentation: More than one media is used to present information
- Multimedia presentation of any information greatly enhances the comprehension capability of the user as it involves use of more of our senses.

COMMON MEDIA:

Common media for storage, access, and transmission of information are:

- Text (alphanumeric characters)
- Graphics (line drawings and images)
- Animation (moving images)
- Audio (sound)
- Video (Videographed real-life events)

Multimedia in information technology refers to use of more than one of these media for information presentation to users.

MULTIMEDIA COMPUTER SYSTEM:

Multimedia computer system is a computer having capability to integrate two or more types of media (text, graphics, animation, audio, and video).

In general, size for multimedia information is much larger than plain text information.

Multimedia computer systems require:

- Faster CPU
- Larger storage devices (for storing large data files)
- Larger main memory (for large data size)
- Good graphics terminals
- I/O devices to play any multimedia

TEXT MEDIA:

Alphanumeric characters are used to present information in text form. Computers are widely used for text processing.

Keyboards, OCRs, computer screens, and printers are some commonly used hardware devices for processing text media.

Text editing, text searching, hypertext, and text importing/exporting are some highly desirable features of a multimedia computer system for better presentation and use of text information.

GRAPHICS MEDIA:

Computer graphics deals with generation, representation, manipulation, and display of pictures (line drawings and images) with a computer.

Locating devices (such as a mouse, a joystick, or a stylus), digitizers, scanners, digital cameras, computer screens with graphics display capability, laser printers, and plotters are some common hardware devices for processing graphics media.

Some desirable features of a multimedia computer system are painting or drawing software, screen capture software, clip art, graphics importing, and software support for high resolution.

ANIMATION MEDIA:

Computer animation deals with generation, sequencing, and display (at a specified rate) of a set of images (called frames) to create an effect of visual change or motion, similar to a movie film (video).

Animation is commonly used in those instances where videography is not possible or animation can better illustrate the concept than video.

Animation deals with displaying a sequence of images at a reasonable speed to create an impression of movement. For a jerk-free full motion animation, 25 to 30 frames per second is required.

Scanners, digital cameras, video capture board interfaced to a video camera or VCR, computer monitors with image display capability, and graphics accelerator board are some common hardware devices for processing animation media.

Some desirable features of a multimedia computer system with animation facility are animation creation software, screen capture software, animation clips, animation file importing, software support for high resolution, recording and playback capabilities, and transition effects.

VIRTUAL REALITY:

Virtual reality is a relatively new technology using which the user can put a pair of goggles and a glove and tour a three-dimensional world that exists only in the computer, but appears realistic to the user.

AUDIO MEDIA:

Computer audio deals with synthesizing, recording, and playback of audio or sound with a computer

Sound board, microphone, speaker, MIDI devices, sound synthesizer, sound editor and audio mixer are some commonly used hardware devices for processing audio media

Some desirable features of a multimedia computer system are audio clips, audio file importing, software support for high quality sound, recording and playback capabilities, text-to-speech conversion software, speech-to-text conversion software, and voice recognition software.

VIDEO MEDIA:

Computer video deals with recording and display of a sequence of images at a reasonable speed to create an impression of movement.

Each individual image of such a sequence is called a frame.

Video camera, video monitor, video board, and video editor are some of the commonly used hardware devices for processing video media.

Some desirable features of a multimedia computer system with video facility are video clips and recording and playback capabilities.

MULTIMEDIA APPLICATION:

Multimedia presentation.

Foreign language learning.

Video games.

Special effects in films.

Multimedia kiosks as help desks.

Animated advertisements.

Multimedia conferencing.

MEDIA CENTER COMPUTER:

- There is a growing trend of owning a personal computer (PC) at home like other electronic equipment
- New terminologies like “infotainment” and “edutainment” have evolved to refer to computers as versatile tools
- Media center PC provides following functionalities:
 - Server as PC, TV, radio, and music system
 - Serve as digital photo album and digital library
 - Server as Game station and DVD/CD Player
 - Allows play, pause, and record of TV programs
 - Provides Electronic Programming Guide (EPG)

Q3) Write a note on each of the following in details.

(a) Modulation Techniques

(b) Multiplexing

(c) Switching Techniques

(d) Optical Fiber Communication

System

(A): Modulation Techniques

Modulation is a process through which audio, video, image or text information is added to an electrical or optical carrier signal to be transmitted over a telecommunication or electronic medium. Modulation enables the transfer of information on an electrical signal to a receiving device that demodulates the signal to extract the blended information.

Modulation is primarily used in telecommunication technologies that require the transmission of data via electrical signals. It is considered the backbone

of data communication because it enables the use of electrical and optical signals as information carriers. Modulation is achieved by altering the periodic waveform or the carrier. This includes carrying its amplitude, frequency and phase. Modulation has three different types:

1. Amplitude Modulation (AM): Amplitude of the carrier is modulated.
2. Frequency Modulation (FM): Frequency of the carrier is modulated.
3. Phase Modulation (PM): Phase of the carrier is modulated.

A modem is a common example/implementation of a modulation technique in which the data is modulated with electrical signals and transmitted over telephone lines. It is later demodulated to receive the data.

Types Of Modulation:

- Analog Modulation
- Digital Modulation

Analog Modulation

In analog modulation, analog signal (sinusoidal signal) is used as a carrier signal that modulates the message signal or data signal. The general function Sinusoidal wave's is shown in the figure below, in which, three parameters can be altered to get modulation – they are amplitude, frequency and phase; so, the types of analog modulation are:

The diagram shows the equation $A_c \cos(2\pi fct + \phi)$ at the top. Three red arrows point upwards from the labels 'Amplitude', 'Frequency', and 'Phase' to the terms A_c , $2\pi fct$, and ϕ respectively. A fourth red arrow points downwards from the label 'Angle' to the entire term $(2\pi fct + \phi)$. Below the diagram, the text '(Frequency= Rate of change of Angle)' is written in red.

Analog Modulation

- Amplitude Modulation (AM)
- Frequency Modulation (FM)
- Phase Modulation (PM)

Amplitude Modulation

Amplitude modulation was developed in the beginning of the 20th century. It was the earliest modulation technique used to transmit voice by radio. This type of modulation technique is used in electronic communication. In this modulation, the amplitude of the carrier signal varies in accordance with the message signal, and other factors like phase and frequency remain constant.

The modulated signal is shown in the below figure, and its spectrum consists of the lower frequency band, upper frequency band and carrier frequency components. This type of modulation requires more power and greater bandwidth; filtering is very difficult. Amplitude modulation is used in computer modems, VHF aircraft radio, and in portable two-way radio

Frequency Modulation

In this type of modulation, the frequency of the carrier signal varies in accordance with the message signal, and other parameters like amplitude and phase remain constant. Frequency modulation is used in different applications like radar, radio and telemetry, seismic prospecting and monitoring newborns for seizures via EEG, etc.

This type of modulation is commonly used for broadcasting music and speech, magnetic tape recording systems, two way radio systems and video transmission systems. When noise occurs naturally in radio systems, frequency modulation with sufficient bandwidth provides an advantage in cancelling the noise.

Phase Modulation

In this type of modulation, the phase of the carrier signal varies in accordance with the message signal. When the phase of the signal is changed, then it affects the frequency. So, for this reason, this modulation is also comes under the frequency modulation.

Generally, phase modulation is used for transmitting waves. It is an essential part of many digital transmission coding schemes that underlie a wide range of technologies like GSM, WiFi, and satellite television. This type of modulation is used for signal generation in al synthesizers, such as the Yamaha DX7 to implement FM synthesis.

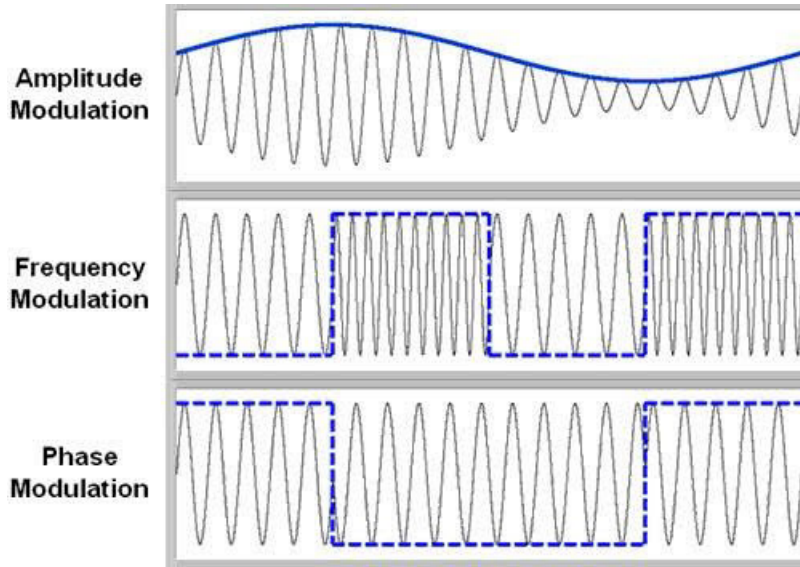

Types of Analog Modulation

Therefore, Analog modulation includes AM, FM and PM and these are more sensitive to noise. If noise enters into a system, it persists and gets carried up to the end receiver. So, this drawback can be overcome by the digital modulation technique.

Digital Modulation

For a better quality and efficient communication, digital modulation technique is employed. The main advantages of the digital modulation over analog modulation include available bandwidth, high noise immunity and permissible power. In digital modulation, a message signal is converted from analog to digital message, and then modulated by using a carrier wave.

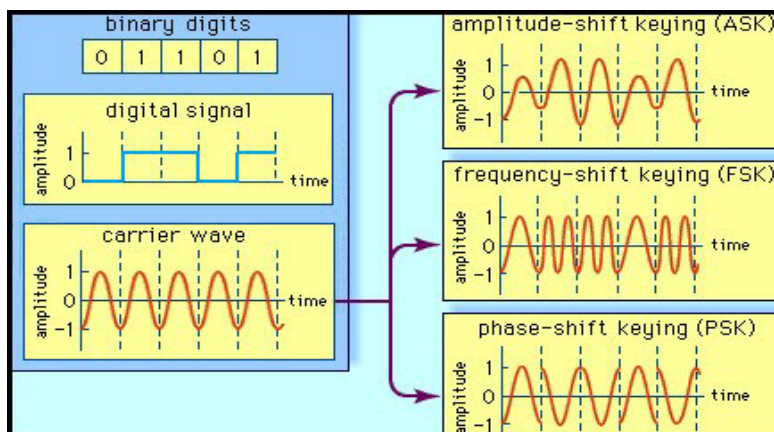

Digital Modulation

The carrier wave is switched on and off to create pulses such that the signal is modulated. Similar to the analog, in this system, the type of the digital modulation

is decided by the variation of the carrier wave parameters like amplitude, phase and frequency.

The most important digital modulation techniques are based on keying such as Amplitude Shift Keying, Frequency Shift Keying, Phase Shift Keying, Differential Phase Shift Keying, Quadrature Phase Shift Keying, Minimum Shift Keying, Gaussian Minimum Shift Keying, Orthogonal Frequency Division Multiplexing, etc., as shown in the figure.

In an Amplitude shift keying, the amplitude of the carrier wave changes based on the message signal or on the base-band signal, which is in digital format. It is sensitive to noise and used for low-band requirements.

In frequency shift keying, the frequency of the carrier wave is varied for each symbol in the digital data. It needs larger bandwidths as shown in the figure. Similarly, the phase shift keying changes the phase of the carrier for each symbol and it is less sensitive to noise.

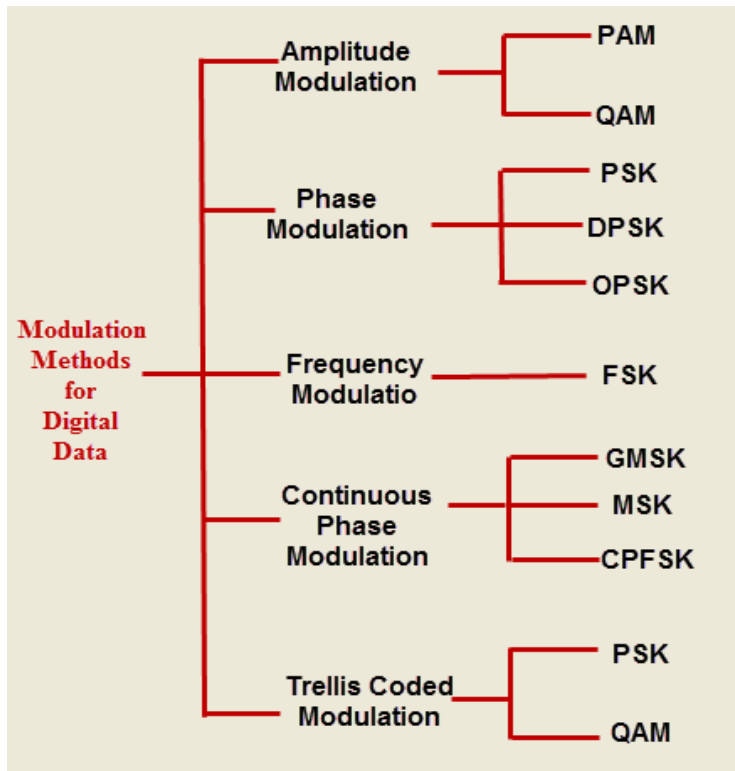

Types of Digital Modulation

(b): Multiplexing

Multiplexing is the process of combining multiple signals into one signal, over a shared medium. If analog signals are multiplexed, it is Analog Multiplexing and if digital signals are multiplexed, that process is Digital Multiplexing.



Multiplexing and Demultiplexing

The process of multiplexing divides a communication channel into several number of logical channels, allotting each one for a different message signal or a data stream to be transferred. The device that does multiplexing can be simply called as a MUX while the one that reverses the process which is demultiplexing, is called as DEMUX.

Types of Multiplexers

There are mainly two types of multiplexers, namely analog and digital. They are further divided into FDM, WDM, and TDM.

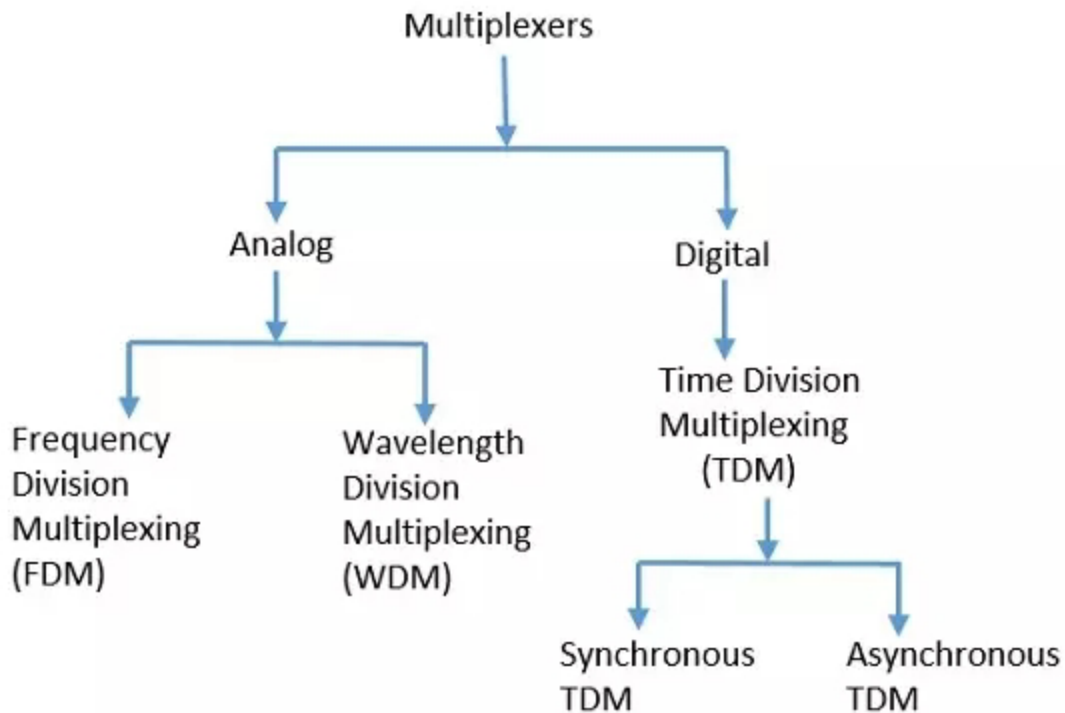

Analog Multiplexing

The analog multiplexing techniques involve signals which are analog in nature. The analog signals are multiplexed according to their frequency (FDM) or wavelength (WDM).

Frequency Division Multiplexing (FDM)

In analog multiplexing, the most used technique is Frequency Division Multiplexing FDM. This technique uses various frequencies to combine streams of data, for sending them on a communication medium, as a single signal.

Example: A traditional television transmitter, which sends a number of channels through a single cable, uses FDM.

Wavelength Division Multiplexing (WDM)

Wavelength Division Multiplexing is an analog technique, in which many data streams of different wavelengths are transmitted in the light spectrum. If the wavelength increases, the frequency of the signal decreases.

Example: Optical fibre Communications use the WDM technique, to merge different wavelengths into a single light for the communication.

Digital Multiplexing

The term digital represents the discrete bits of information. Hence the available data is in the form of frames or packets, which are discrete.

Time Division Multiplexing (TDM)

In TDM, the time frame is divided into slots. This technique is used to transmit a signal over a single communication channel, with allotting one slot for each message. Of all the types of TDM, the main ones are Synchronous and Asynchronous TDM.

Synchronous TDM

In Synchronous TDM, the input is connected to a frame. If there are 'n' number of connections, then the frame is divided into 'n' time slots. One slot is allocated for each input line. In this technique, the sampling rate is common to all signals and hence same clock input is given. The mux allocates the same slot to each device at all times.

Asynchronous TDM

In Asynchronous TDM, the sampling rate is different for each of the signals and the clock signal is also not in common. If the allotted device, for a time-slot, transmits nothing and sits idle, then that slot is allotted to another device, unlike synchronous.

(c): Switching Techniques

In large networks, there may be more than one paths for transmitting data from **sender** to receiver. Selecting a path that data must take out of the available options is called **switching**. There are two popular switching techniques – circuit switching and packet switching.



Circuit Switching

When a dedicated path is established for data transmission between sender and receiver, it is called circuit switching. When any network node wants to send data, be it audio, video, text or any other type of information, a **call request signal** is sent to the receiver and acknowledged back to ensure availability of dedicated path. This dedicated path is then used to send data. ARPANET used circuit switching for communication over the network.

Advantages of Circuit Switching

Circuit switching provides these advantages over other switching techniques –

- Once path is set up, the only delay is in data transmission speed
- No problem of congestion or garbled message

Disadvantages of Circuit Switching

Circuit switching has its disadvantages too –

- Long set up time is required
- A request token must travel to the receiver and then acknowledged before any transmission can happen

- Line may be held up for a long time

Packet Switching

As we discussed, the major problem with circuit switching is that it needs a dedicated line for transmission. In packet switching, data is broken down into small packets with each packet having source and destination addresses, travelling from one router to the next router.

(d) Optical Fiber Communication System

Fibre optic communication has revolutionised the telecommunications industry. It has also made its presence widely felt within the data networking community as well. Using fibre optic cable, optical communications have enabled telecommunications links to be made over much greater distances and with much lower levels of loss in the transmission medium and possibly most important of all, fiber optical communications has enabled much higher data rates to be accommodated.

As a result of these advantages, fibre optic communications systems are widely employed for applications ranging from major telecommunications backbone infrastructure to Ethernet systems, broadband distribution, and general data networking.

Development of fibre optics

Since the earliest days of telecommunications there has been an ever increasing need to transmit more data even faster. Initially single line wires were used. These gave way to coaxial cables that enabled several channels to be transmitted over the same cable. However these systems were limited in bandwidth and optical systems were investigated.

Optical communications became a possibility after the first lasers were developed in the 1960s. The next piece of the jigsaw fell into place when the first optical fibers with a sufficiently low loss for communications purposes were developed in the 1970s. Then, during the late 1970s a considerable amount of research was undertaken. This resulted in the installation of the first optical fibre telecommunications system. It ran over a distance of 45 km and used a wavelength

of 0.5 mm and had a data rate of just 45 Mbps - a fraction of what is possible today.

Since then, considerable improvements have been made in the technology. Data rates have improved and in addition to this the performance of the optical fibre has been improved to enable much greater distances to be achieved between repeaters. As an indication of this the speeds that can now be achieved along through a fibre optic system exceed 10 Tbps.

When the first fibre optic transmission systems were being developed, it was thought that the fibre optic cabling and technology would be prohibitively expensive. However, this has not been the case and costs have fallen to the extent that fibre optics now provides the only viable option for many telecommunications applications. In addition to this it is also used in many local area networks where speed is a major requirement.

Advantages of fibre optics for communications

There are a number of compelling reasons that lead to the widespread adoption of fibre optic cabling for telecommunications applications:

Much lower levels of signal attenuation

Fibre optic cabling provides a much higher bandwidth allowing more data to be delivered

Fibre optic cables are much lighter than the coaxial cables that might otherwise be used.

Fibre optics do not suffer from stray interference pickup that occurs with coaxial cabling

Fibre optic transmission system

Any fibre optic data transmission system will comprise a number of different elements. There are three major elements (marked in bold), and a further one that is vital for practical systems:

- **Transmitter (light source)**
- **Fibre optic cable**
- **Optical repeater**

- **Receiver (Detector)**

The different elements of the system will vary according to the application. Systems used for lower capacity links, possibly for local area networks will employ somewhat different techniques and components to those used by network providers that provide extremely high data rates over long distances. Nevertheless the basic principles are the same whatever the system.

In the system the transmitter of light source generates a light stream modulated to enable it to carry the data. Conventionally a pulse of light indicates a "1" and the absence of light indicates "0". This light is transmitted down a very thin fibre of glass or other suitable material to be presented at the receiver or detector. The detector converts the pulses of light into equivalent electrical pulses. In this way the data can be transmitted as light over great distances.

Fibre optic transmitter

Although the original telecommunications fibre optic systems would have used large lasers, today a variety of semiconductor devices can be used. The most commonly used devices are light emitting diodes, LEDs, and semiconductor laser diodes.

The simplest transmitter device is the LED. Its main advantage is that it is cheap, and this makes it ideal for low cost applications where only short runs are needed. However they have a number of drawbacks. The first is that they offer a very low level of efficiency. Only about 1% of the input power enters the optical fibre, and this means that high power drivers would be needed to provide sufficient light to enable long distance transmissions to be made. The other disadvantage of LEDs is that they produce what is termed incoherent light that covers a relatively wide spectrum. Typically the spectral width is between 30 and 60 nm. This means that any chromatic dispersion in the fibre will limit the bandwidth of the system.

In view of their performance, LEDs are used mainly in local-area-network applications where the data rates are typically in the range 10-100 Mb/s and transmission distances are a few kilometres.

Where higher levels of performance are required, i.e. it is necessary that the fibre optic link can operate over greater distances and with higher data rates, then lasers are used. Although more costly, they offer some significant advantages. In the first instance they are able to provide a higher output level, and in addition to this the light output is directional and this enables a much higher level of efficiency in the

transfer of the light into the fibre optic cable. Typically the coupling efficiency into a single mode fibre may be as high as 50%. A further advantage is that lasers have a very narrow spectral bandwidth as a result of the fact that they produce coherent light. This narrow spectral width enables the lasers to transmit data at much higher rates because modal dispersion is less apparent. Another advantage is that semiconductor lasers can be modulated directly at high frequencies because of short recombination time for the carriers within the semiconductor material.

Laser diodes are often directly modulated. This provides a very simple and effective method of transferring the data onto the optical signal. This is achieved by controlling current applied directly to the device. This in turn varies the light output from the laser. However for very high data rates or very long distance links, it is more effective to run the laser at a constant output level (continuous wave). The light is then modulated using an external device. The advantage of using an external means of modulation is that it increases the maximum link distance because an effect known as laser chirp is eliminated. This chirp broadens the spectrum of the light signal and this increases the chromatic dispersion in the fibre optic cable.

Fibre optic cable

The full details and description of fibre optic cabling are found in a separate article / tutorial on this area of the website. In essence a fibre optic cable consists of core, around which is another layer referred to as the cladding. Outside of this there is a protective outer coating.

The fibre optic cables operate because their cladding has a refractive index that is slightly lower than that of the core. This means that light passing down the core undergoes total internal reflection when it reaches the core / cladding boundary, and it is thereby contained within the core of the optical fibre.

Repeaters and amplifiers

There is a maximum distance over which signals may be transmitted over fibre optic cabling. This is limited not only by the attenuation of the cable, but also the distortion of the light signal along the cable. In order to overcome these effects and transmit the signals over longer distances, repeaters and amplifiers are used.

Opto-electric repeaters may be used. These devices convert the optical signal into an electrical format where it can be processed to ensure that the signal is not distorted and then converted back into the optical format. It may then be transmitted along the next state of the fibre optic cable.

An alternative approach is to use an optical amplifier. These amplifiers directly amplify the optical signal without the need to convert the signal back into an electrical format. The amplifiers consist of a length of fibre optic cable that is doped with a rare earth mineral named Erbium. The treated fibre cable is then illuminated or pumped with light of a shorter wavelength from another laser and this serves to amplify the signal that is being carried.

In view of the much reduced cost of fibre optic amplifiers over repeaters, amplifiers are far more widely used. Most repeaters have been replaced, and amplifiers are used in virtually all new installations these days.

Receivers

Light travelling along a fibre optic cable needs to be converted into an electrical signal so that it can be processed and the data that is carried can be extracted. The component that is at the heart of the receiver is a photo-detector. This is normally a semiconductor device and may be a p-n junction, a p-i-n photo-diode or an avalanche photo-diode. Photo-transistors are not used because they do not have sufficient speed.

Once the optical signal from the fibre optic cable has been applied to the photo-detector and converted into an electrical format it can be processed to recover the data which can then be passed to its final destination.

Fibre optic transmission of data is generally used for long distance telecommunications network links and for high speed local area networks. Currently fibre optics is not used for the delivery of services to homes, although this is a long term aim for many telcos. By using optical fibre cabling here, the available bandwidth for new services would be considerably higher and the possibility of greater revenues would increase. Currently the cost of this is not viable, although it is likely to happen in the medium term.

In recent years, optical fibres, or optical fibers and fibre optic cabling has fallen in cost, making it fall within the economic reach of many more telecommunications and data networking applications. As a result fibre optics are now in widespread use, and form the backbone of most telecommunications networks and many local area data networks.

While there are many components used in building up a fibre optic link (fiber optic link), the fibre optic cabling is obviously the key element.

Optical fibre construction

Fibre optic technology relies on the fact that it is possible to send a light beam along a thin fibre suitably constructed. A fibre optic cable consists of a glass or silica core. The core of the optical fibre is surrounded by a similar material, i.e. glass or silica, called the cladding, that has a refractive index that is slightly lower than that of the core. It is found that even when the cladding has a slightly higher refractive index, the light passing down the core undergoes total internal reflection, and it is thereby contained within the core of the optical fibre.

The Outside the cladding there is placed a plastic jacket. This is used to provide protection to the optical fibre itself. In addition to this, optical fibres are usually grouped together in bundles and these are protected by an overall outer sheath. This not only provides further protection but also serves to keep the optical fibres together.

Optical fibre types

There is a variety of different types of fibre optic cable that can be used, and there are a number of ways in which types may be differentiated. There are two major categories:

- Step index fibre optic cabling
- Graded index fibre optic cabling

The step index cable refers to cable in which there is a step change in the refractive index between the core and the cladding. This type is the more commonly used. The other type, as indicated by the name, changes more gradually over the diameter of the fibre. Using this type of cable, the light is refracted towards the centre of the cable.

Optical fibres or optical fibers can also be split into single mode fibre, and multimode fibre. Mention of both single mode fiber and multi-mode fiber is often seen in the literature.

Single mode fiber This form of optical fibre is the type that is virtually exclusively used these days. It is found that if the diameter of the optical fibre is reduced to a few wavelengths of light, then the light can only propagate in a straight line and does not bounce from side to side of the fibre. As the light can only travel in this single mode, this type of cable is called a single mode fibre. Typically single mode fibre core are around eight to ten microns in diameter, much smaller than a hair.

Single mode fiber does not suffer from multi-modal dispersion and this means that it has a much wider bandwidth. The main limitation to the bandwidth is what is termed chromatic dispersion where different colours, i.e. Wavelengths propagate at different speeds. Chromatic dispersion of the optical fibre cable occurs within the centre of the fibre itself. It is found that it is negative for short wavelengths and changes to become positive at longer wavelengths. As a result there is a wavelength for single mode fiber where the dispersions is zero. This generally occurs at a wavelength of around 1310 nm and this is the reason why this wavelength is widely used.

The disadvantage of single mode fibre is that it requires high tolerance to be manufactured and this increases its cost. Against this the fact that it offers superior performance, especially for long runs means that much development of single mode fiber has been undertaken to reduce the costs.

Multimode fiber This form of fibre has a greater diameter than single mode fibre, being typically around 50 microns in diameter, and this makes them easier to manufacture than the single mode fibres.

Multimode optical fiber has a number of advantages. As it has a wider diameter than single mode fibre it can capture light from the light source and pass it to the receiver with a high level of efficiency. As a result it can be used with low cost light emitting diodes. In addition to this the greater diameter means that high precision connectors are not required. However this form of optical fibre cabling suffers from a higher level of loss than single mode fibre and in view of this its use is more costly than might be expected at first sight. It also suffers from multi-mode modal dispersion and this severely limits the usable bandwidth. As a result it has

not been widely used since the mid 1980s. Single mode fiber cable is the preferred type.

Attenuation within an optical fibre

Although fibre optic cables offer a far superior performance to that which can be achieved with other forms of cable, they nevertheless suffer from some levels of attenuation. This is caused by several effects:

- **Loss associated with the impurities** There will always be some level of impurity in the core of the optical fibre. This will cause some absorption of the light within the fibre. One major impurity is water that remains in the fibre.
- **Loss associated with the cladding** When light reflects off the interface between the cladding and the core, the light will actually travel into the core a small distance before being reflected back. This process causes a small but significant level of loss and is one of the main contributors to the overall attenuation of a signal along an fibre optic cable.
- **Loss associated with the wavelength** It is found that the level of signal attenuation in the optical fibre depends the wavelength used. The level increases at certain wavelengths as a result of certain impurities.

Despite the fact that attenuation is an issue, it is nevertheless possible to transmit data along single mode fibres for considerable distances. Lines carrying data rates up to 50 Gbps are able to cover distances of 100 km without the need for amplification.

Materials used for optical fibres

There are two main types of material used for optical fibres. These are glass and plastic. They offer widely different characteristics and therefore fibres made from the two different substances find uses in very different applications.

Optical fibre sizes

One of the major ways of specifying optical fibre cables is by the diameters of the inner core and the external cladding. As may be expected there are industry standards for these and this helps in reducing the variety of fittings needed for connectors, splices and the tools needed for fitting.

The standard for most optical fibres is 125 microns (um) for the cladding and 245 microns (um) for the outer protective coating. Multimode optical fibres have core sizes of either 50 or 62.5 microns whereas the standards for single mode fibres is approximately 8 to 10 microns.

When specifying optical fibre cables, the diameters usually form the major part of the cable specification. A multimode fibre with a core diameter of 50 microns and a cladding diameter of 125 microns would be referred to as a 50/125 fibre.

In addition to the specification of the diameter, other parameters such as the loss, etc are also required, but these elements do not form part of the cable type in the same way as the diameter.

There are many occasions when it is necessary to connect a fibre optic cable to another item. It may be that the fibre optic cable needs to be connected to another cable, or to an electronic interface device where the optical signal is converted to an electrical signal or to a light source. It is necessary that the fibre optic cable is correctly interfaced so that the minimum amount of light is lost. To achieve this it is necessary to use the correct form of fibre optic connector. In these cases fibre optic connectors are required.

While fibre optic connectors offer a very convenient method of connecting fibre optic cables, they should only be used where necessary. They introduce a loss at each connection. Typically the value is between 10 and 20 percent. Against this they make reconfiguring systems very much easier.

Connector basics

The fibre optic connector basically consists of a rigid cylindrical barrel surrounded by a sleeve. The barrel provides the mechanical means by which the connector is held in place with the mating half. A variety of methods are used to ensure the connector is held in place, ranging from screw fit, to latch arrangements. The main requirement is that the end of the fibre optic cable is held accurately in place so that the maximum light transfer occurs.

As it is imperative that the optical fibre is held securely and accurately in place, connectors will normally be designed so that the fibre is glued in place, and in addition to this strain relief is also provided

Fibre ends may also be polished. For single mode fibre, the ends may be polished with a slight convex curvature so that the centres of the cables from the two connectors achieve physical contact. This approach reduces the back reflections, although the level of loss may be slightly higher.

Fibre optic connector types

Fibre optic connectors (fiber optic connectors) come in a variety of formats. These different fibre optic connectors may be used in slightly different applications or under different circumstances, as each type has its own capabilities.

When choosing a fibre optic connector, it is necessary to ensure that its properties meet the needs of the particular application in question. Some fibre optic connectors may be suitable for different optical fibres, and this needs to be taken into consideration.

There is a wide variety of different fiber optic connectors available. A selection of some is given below:

- **FC/PC** This form of fibre optic connector is used for single-mode fiber optic cable. It provides very accurate positioning of the single-mode fiber optic cable with respect to transmitter (optical source) or the receiver (optical detector).
- **SC** This form of connector is mainly used with single-mode fiber optic cables. The connector is simple low cost and reliable. The location and alignment is provided using a ceramic ferrule. It also has a locking tab to enable it to be mated and removed without fear of it accidentally falling loose.
- **Plastic fiber optic cable connectors** As the name implies, these fibre optic cable connectors are only used with plastic fibre optic cabling.

Rather than using optical fibre connectors, it is possible to splice two optical fibres together. An fibre optic splice is defined by the fact that it gives a permanent or relatively permanent connection between two fibre optic cables. That said, some manufacturers do offer fibre optic splices that can be disconnected, but nevertheless they are not intended for repeated connection and disconnection.

There are many occasions when fibre optic splices are needed. One of the most common occurs when a fibre optic cable that is available is not sufficiently long for the required run. In this case it is possible to splice together two cables to make a permanent connection. As fibre optic cables are generally only manufactured in lengths up to about 5 km, when lengths of 10 km are required, for example, then it is necessary to splice two lengths together.

Fibre optic splices can be undertaken in two ways:

- Mechanical splices
- Fusion splices

The mechanical splices are normally used when splices need to be made quickly and easily. To undertake a mechanical fibre optic splice it is necessary to strip back the outer protective layer on the fibre optic cable, clean it and then perform a precision cleave or cut. When cleaving (cutting) the fibre optic cable it is necessary

to obtain a very clean cut, and one in which the cut on the fibre is exactly at right angles to the axis of the fibre.

Once cut the ends of the fibres to be spliced are placed into a precision made sleeve. They are accurately aligned to maximise the level of light transmission and then they are clamped in place. A clear, index matching gel may sometimes be used to enhance the light transmission across the joint.

Mechanical fibre optic splices can take as little as five minutes to make, although the level of light loss is around ten percent. However this level is better than that which can be obtained using a connector.

Fusion splices form the other type of fibre optic splice that can be made. This type of connection is made by fusing or melting the two ends together. This type of splice uses an electric arc to weld two fibre optic cables together and it requires specialised equipment to perform the splice. The protective coating from the fibres to be spliced is removed from the ends of the fibres. The ends of the fibre optic cable are then cut, or to give the correct term they are cleaved with a precision cleaver to ensure that the cuts are exactly perpendicular. The next stage involves placing the two optical fibres into a holder in the fibre optic splicer. First the ends of the cable are inspected using a magnifying viewer. Then the ends of the fibre are automatically aligned within the fibre optic splicer. Then the area to be spliced is cleaned of any dust often by a process using small electrical sparks. Once complete the fibre optic splicer then uses a much larger spark to enable the temperature of the glass in the optical fibre to be raised above its melting point and thereby allowing the two ends to fuse together. The location spark and the energy it contains are very closely controlled so that the molten core and cladding do not mix to ensure that any light loss in the fibre optic splice is minimised.

Once the fibre optic splice has been made, an estimate of the loss is made by the fibre optic splicer. This is achieved by directing light through the cladding on one side and measuring the light leaking from the cladding on the other side of the splice.

The equipment that performs these splices provides computer controlled alignment of the optical fibres and it is able to achieve very low levels of loss, possibly a quarter of the levels of mechanical splices. However this comes at a process as fusion welders for fibre optic splices are very expensive.

Mechanical and fusion splices

The two types of fibre optic splices are used in different applications. The mechanical ones are used for applications where splices need to be made very quickly and where the expensive equipment for fusion splices may not be available. Some of the sleeves for mechanical fibre optic splices are advertised as allowing connection and disconnection. In this way a mechanical splice may be used in applications where the splice may be less permanent.

Fusion splices offer a lower level of loss and a high degree of permanence. However they require the use of the expensive fusion splicing equipment. In view of this they tend to be used more for the long high data rate lines that are installed that are unlikely to be changed once installed.

Q 4 What is OSI reference model explain each layer of OSI model in details.

The OSI Model Defined

The OSI Model (Open Systems Interconnection Model) is a conceptual framework used to describe the functions of a networking system. The OSI model characterizes computing functions into a universal set of rules and requirements in order to support interoperability between different products and software. In the OSI reference model, the communications between a computing system are split into seven different abstraction layers: Physical, Data Link, Network, Transport, Session, Presentation, and Application.

Created at a time when network computing was in its infancy, the OSI was published in 1984 by the International Organization for Standardization (ISO). Though it does not always map directly to specific systems, the OSI Model is still used today as a means to describe Network Architecture.

The 7 Layers of the OSI Model

Physical Layer

The lowest layer of the OSI Model is concerned with electrically or optically transmitting raw unstructured data bits across the network from the physical layer of the sending device to the physical layer of the receiving device. It can include specifications such as voltages, pin layout, cabling, and radio frequencies. At the physical layer, one might find

“physical” resources such as network hubs, cabling, repeaters, network adapters or modems.

Data Link Layer

At the data link layer, directly connected nodes are used to perform node-to-node data transfer where data is packaged into frames. The data link layer also corrects errors that may have occurred at the physical layer.

The data link layer encompasses two sub-layers of its own. The first, media access control (MAC), provides flow control and multiplexing for device transmissions over a network. The second, the logical link control (LLC), provides flow and error control over the physical medium as well as identifies line protocols.

Network Layer

The network layer is responsible for receiving frames from the data link layer, and delivering them to their intended destinations among based on the addresses contained inside the frame. The network layer finds the destination by using logical addresses, such as IP (internet protocol). At this layer, routers are a crucial component used to quite literally route information where it needs to go between networks.

Transport Layer

The transport layer manages the delivery and error checking of data packets. It regulates the size, sequencing, and ultimately the transfer of data between systems and hosts. One of the most common examples of the transport layer is TCP or the Transmission Control Protocol.

Session Layer

The session layer controls the conversations between different computers. A session or connection between machines is set up, managed, and terminated at layer 5. Session layer services also include authentication and reconnections.

Presentation Layer

The presentation layer formats or translates data for the application layer based on the syntax or semantics that the application accepts. Because of this, it at times also called the syntax layer. This layer can also handle the encryption and decryption required by the application layer.

Application Layer

At this layer, both the end user and the application layer interact directly with the software application. This layer sees network services provided to end-user applications such as a web browser or Office 365. The application layer identifies communication partners, resource availability, and synchronizes communication.