

DIGITAL LOGIC DESIGN

Shift Register

Sir. Muhammad Amin

Muhammad Yasir

15459

LAB# 10

SHIFT REGISTER

AIM:

To Design and verify the function of Truth Table.

OBJECTIVES:

To investigate the operation of the shift registers.

BACKGROUND:

A register capable of shifting its binary information either to right or to the left is called a shift register. The simplest possible shift register is one that uses only flipflops, The Q output of a given flip-flop is connected to the D input of the flip-flop at its right.

Each clock pulse shifts the contents of the register one-bit position to the right. The serial input determines what goes into the leftmost flip-flop during the shift. The serial output is taken from the output of the rightmost flip-flop prior to the application of a pulse. Although this register shifts its contents to the right, if we turn the page upside down; we find that the register shifts its contents to the left. Thus, a unidirectional shift register can function either as a



shift-right or as shift-left register.

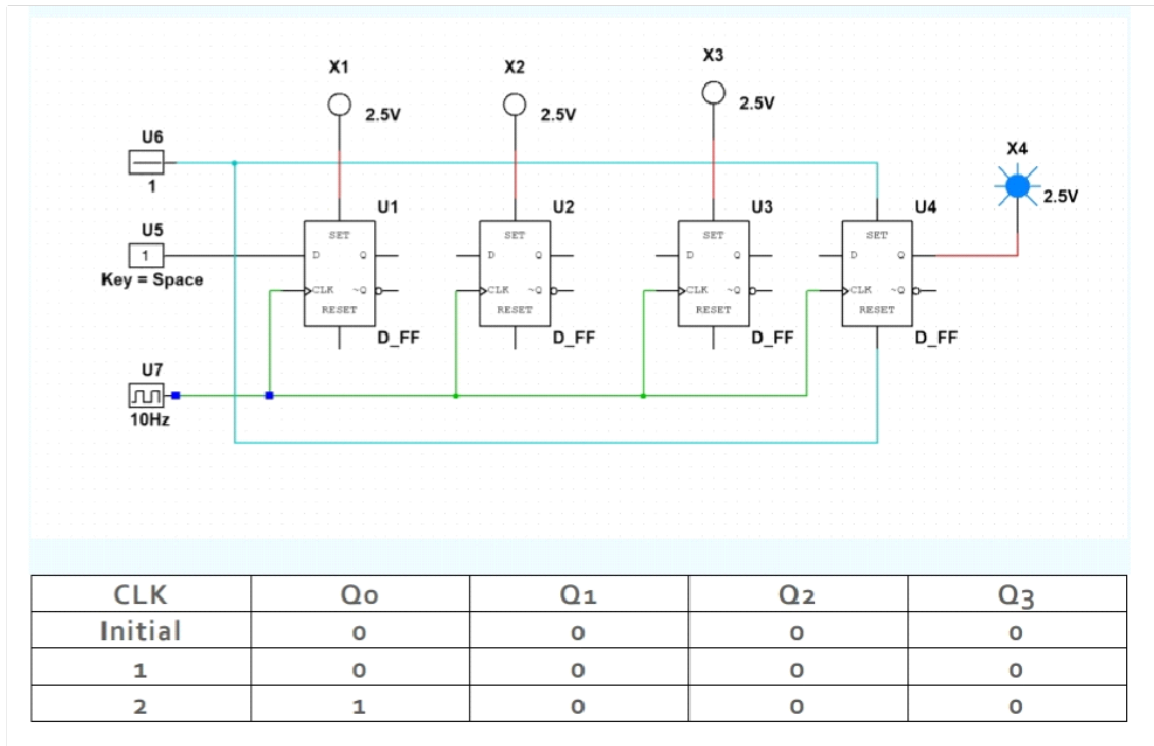

3	0	1	0	0
4	1	0	1	0

DISCUSSION:

Excess-3 code is a 4-bit un-weighted code and can be obtained from the corresponding value of BCD code by adding three to each coded number. Excess-3 code is self-complementing in nature because 1â~AZ' s complement of the coded number yields complements of number itself.

CONCLUSION:

various types of shift register have been implemented and verified using ICs.

