

Name:

Muhammad Bilal Elahi

ID:

15434

Department:

Computer science

Submitted to:

Sir Muhammad Amin

MULTIPLEXER

AIM:

To the Truth Table of 4:1 Multiplexer using IC 74153.

OBJECTIVES:

- To get familiar with the concept of multiplexing
- To get familiar with MSI (medium scale integration) technology.

PROCEDURE:

- Collect the components necessary to accomplish this experiment.
- Plug the IC chip into the breadboard.
- Connect the supply voltage and ground lines to the chips. PIN7 = Ground and PIN14 = +5V.
- Make connections as shown in the respective circuit diagram.
- Connect the inputs of the gate to the input switches of the LED.
- Connect the output of the gate to the output LEDs.
- Once all connections have been done, turn on the power switch of the bread-board
- Operate the switches and fill in the truth table (Write "1" if LED is ON and "0" if L1 is OFF Apply the various combination of inputs according to the truth table and observe the condition of Output LEDs.

MULTIPLEXER:

A data selector, more commonly called a Multiplexer, shortened to "MUX" or "MPX", is combinational logic switching devices that operate like a very fast acting multiple position rotary switches. They connect or control, multiple input lines called "channels" consisting of either 2, 4, 8 or 16 individual inputs, one at a time to an output. Then the job of a multiplexer is to allow multiple signals to share a single common output. For example, a single 8-channel multiplexer would connectome of its eight inputs to the single data output. The Boolean expression for this 4-to-1 Multiplexer above with inputs I0 to I3 and data select lines S0, S1 is given as.

$$Y = S_0S_1I_0 + S_0S_1I_1 + S_0S_1I_2 + S_0S_1I_3$$

Table:

A	B	Z
0	0	0
0	1	0
1	0	1
1	1	1

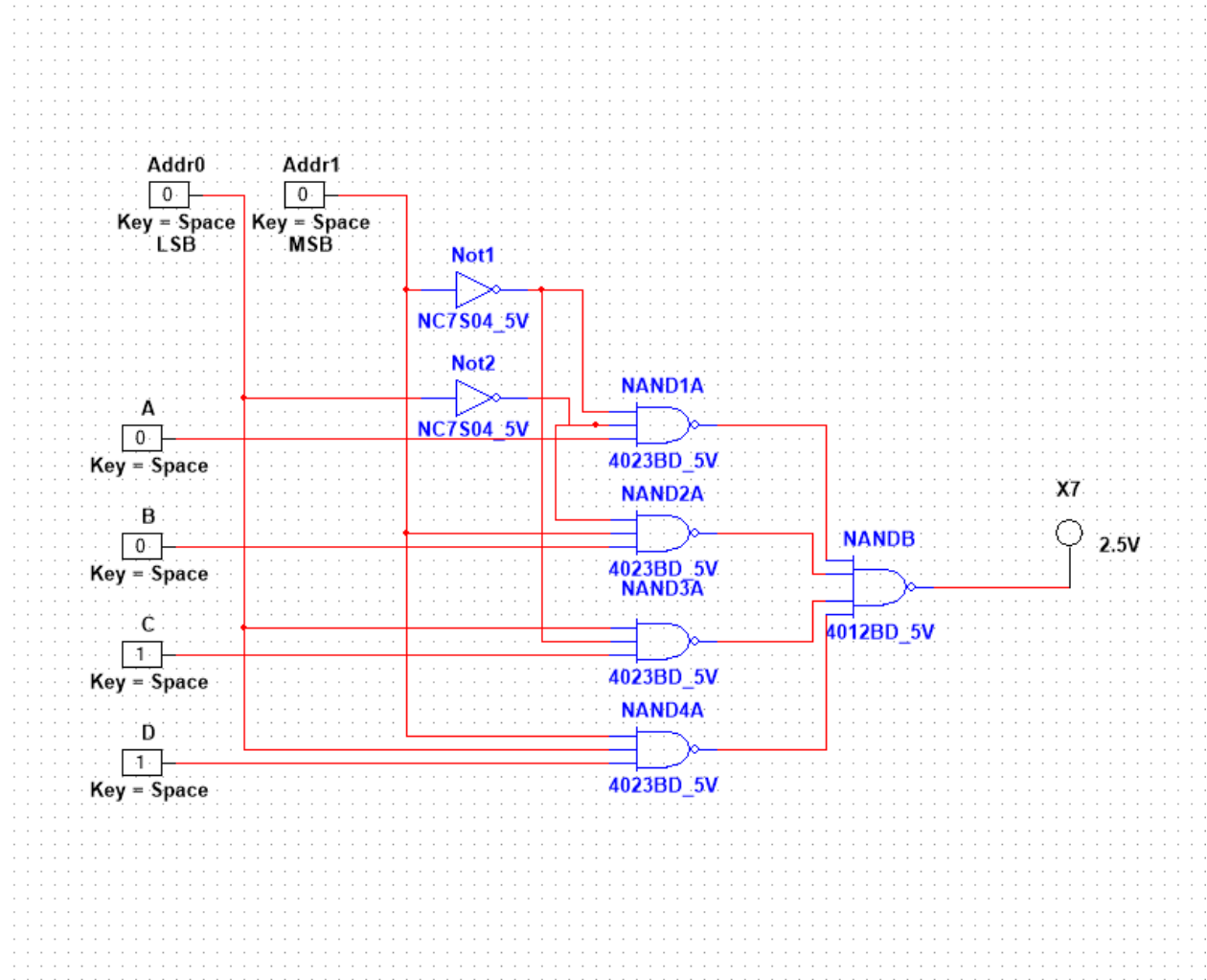

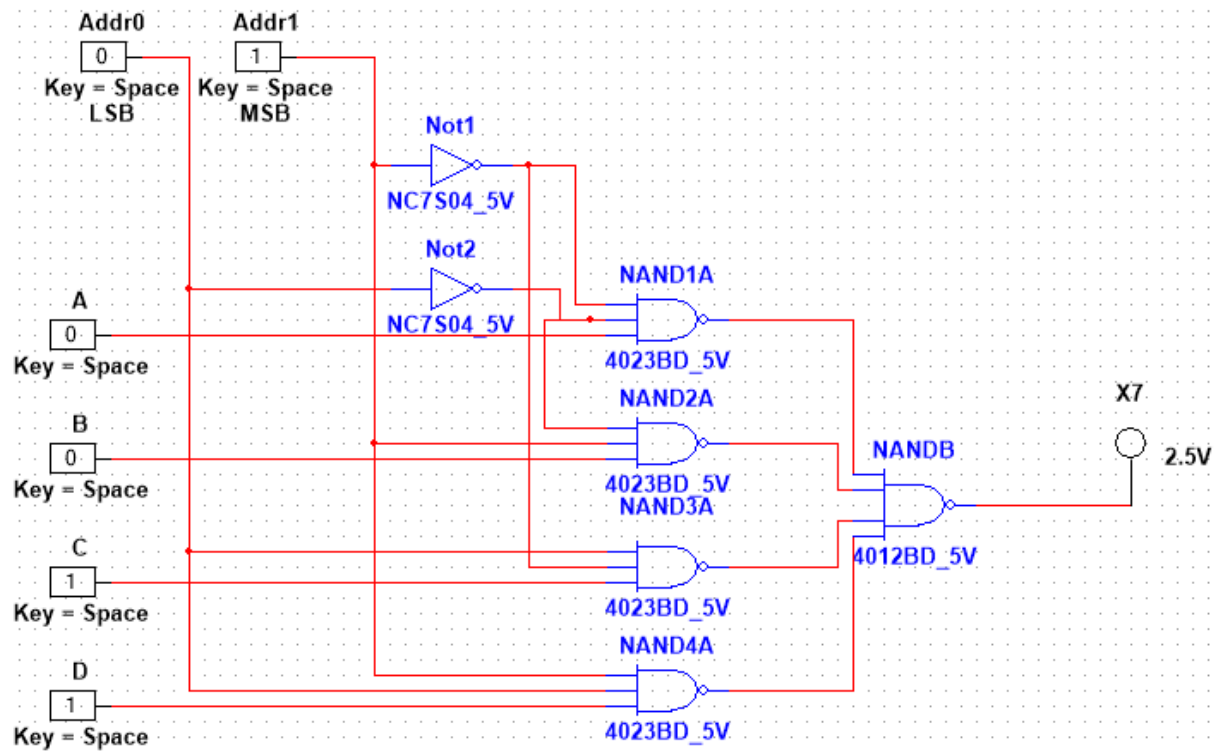

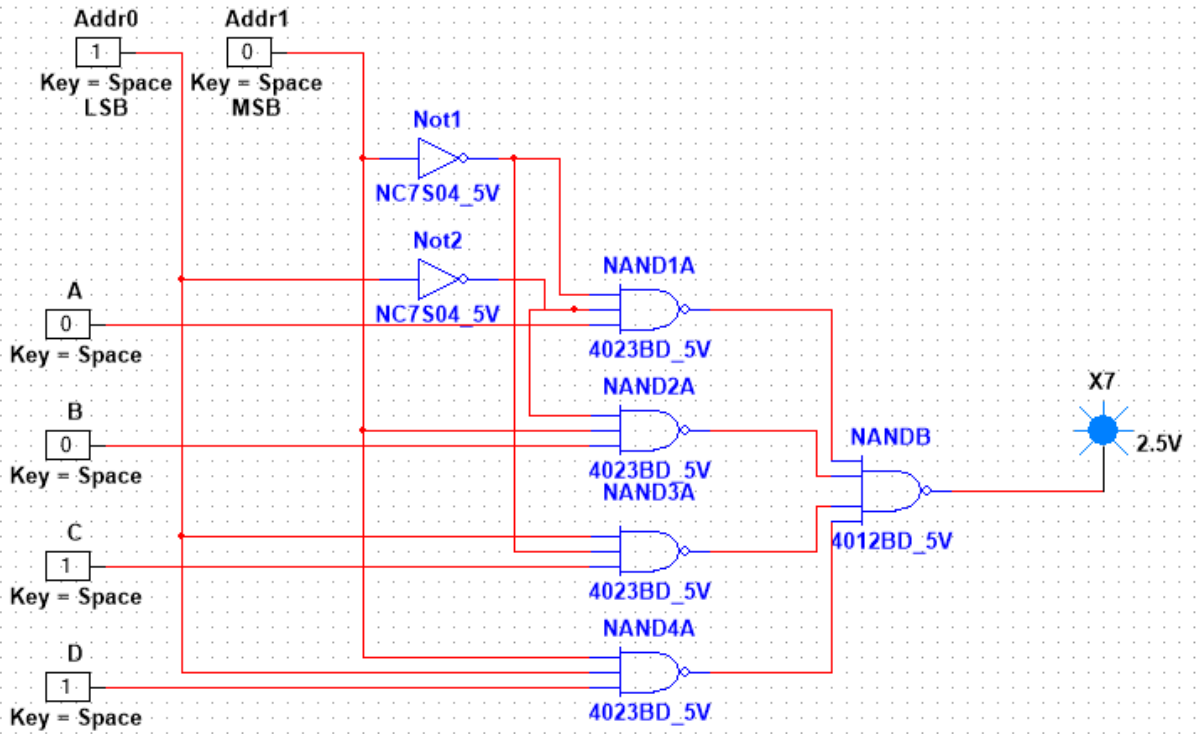

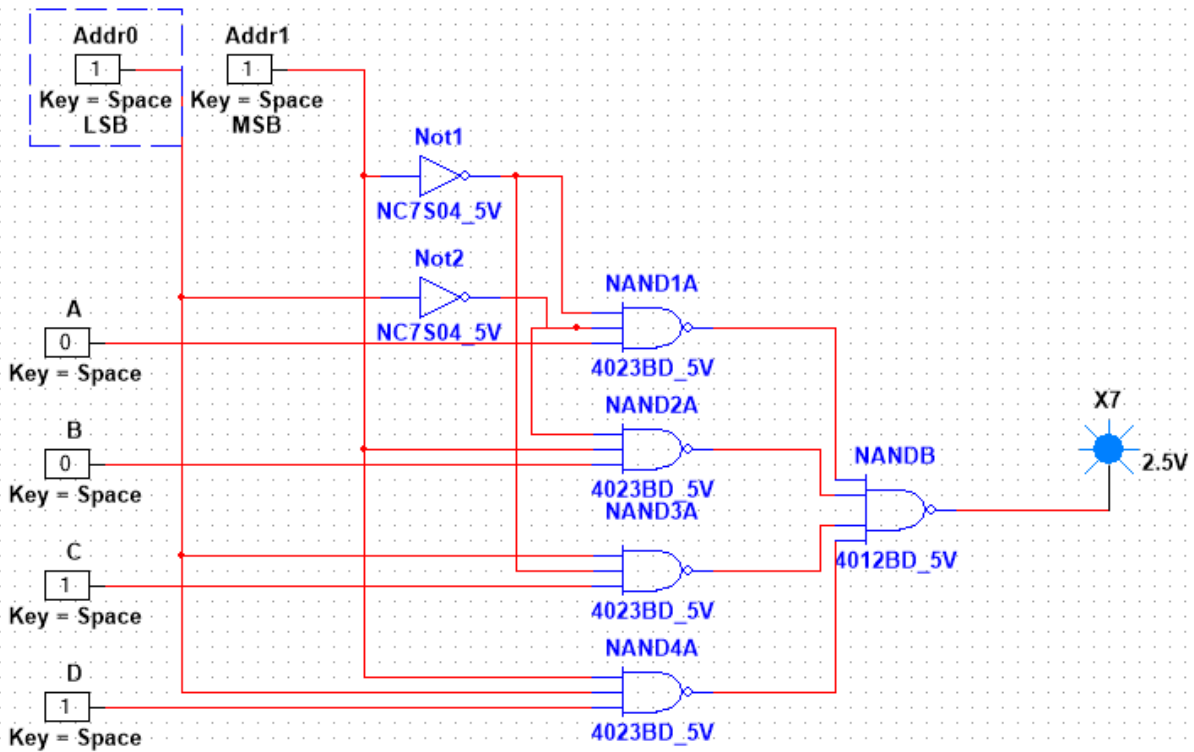

RESULTS AND ANALYSIS:

Verified the truth table as follows. The input data was routed to output by varying the addresses on select lines

CONCLUSION:

The truth table of 4:1 MUX using IC74153 has been verified.