

Name : irfan ullah

ID : 15431

LAB : no 10

Subject : Digital Logic Design

Course code(CS) : CSC-201

Program : BC (CS)

SHIFT REGISTER

AIM:

To Design and verify the function of Truth Table.

OBJECTIVES:

To investigate the operation of the shift registers.

BACKGROUND:

A register capable of shifting its binary information either to right or to the left is called a shift register.

The simplest possible shift register is one that uses only flipflops,

The Q output of a given flip-flop is connected to the D input of the flip-flop at its right. Each clock pulse shifts the contents of the register one-bit position to the right. The serial input determines what goes into the leftmost flip-flop during the shift. The serial output is taken from the output of the rightmost flip-flop prior to the application of a pulse. Although this register shifts its contents to the right, if we turn the page upside down; we find that the register shifts its contents to the left. Thus, unidirectional shift register can function either as a shift-right or as shift-left register

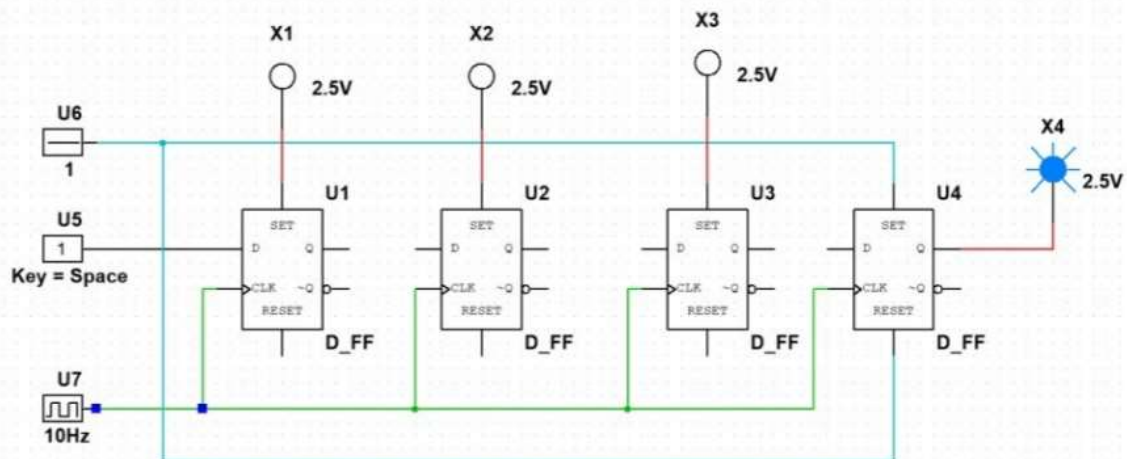

CLK	Q ₀	Q ₁	Q ₂	Q ₃
Initial	0	0	0	0
1	0	0	0	0
2	1	0	0	0
3	0	1	0	0
4	1	0	1	0

DISCUSSION:

Excess-3 code is a 4-bit un-weighted code and can be obtained from the corresponding value of BCD code by adding three to each coded number. Excess-3 code is self-complementing in nature because 1's complement of the coded number yields complements of number itself.

CONCLUSION:

various types of shift register have been implemented and verified using ICs.