

*DIGITAL LOGIC DESIGN*

*GRAY TO BINARY CODE*

*Sir. Muhammad Amin*

*Muhammad Yasir*

*15459*

*Csc-201*

*LAB# 9*

*GRAY TO BINARY CODE*

**AIM:**

*To Design and verify the truth table of code conversion from gray to binary code (4 bit) using basic Logic Gates*

**OBJECTIVES:**

*Design of different combinational circuits and their applications using basic logic gates.*

*Creation and observation of the four-bit binary code number representation sequence*

*Exercising the design of code conversion logic circuits,*

*Creating the truth table of conversion functions from Gray to binary code*

*Developing skills in simplification of specified logical functions*

**PROCEDURE:**

*Collect the components necessary to accomplish this experiment.*

*Plug the IC chip into the breadboard.*



*Connect the supply voltage and ground lines to the chips. PIN7 = Ground and PIN14 = +5V.*

*Make connections as shown in the respective circuit diagram.*

*Connect the inputs of the gate to the input switches of the LED.*

*Connect the output of the gate to the output LEDs.*

*Once all connections have been done, turn on the power switch of the breadboard*

*Operate the switches and fill in the truth table Write "1" if LED is ON and "0" if L1 is OFF Apply the various combination of inputs according to the truth table and observe the condition of Output LEDs.*

### **GRAY TO BINARY CODE:**

*Gray-to Binary Converter is an interesting application for the exclusive-OR gate is a logic gate to change a gray number to its equivalent in binary Code. The logic circuit can be used to convert a 4-bit gray number ABCD into its binary-code equivalent, B3, B2, B1 and B0*

### **OBSERVATION TABLE:**



BCD				GRAY			
A	B	C	D	B <sub>3</sub>	B <sub>2</sub>	B <sub>1</sub>	B <sub>0</sub>
0	0	0	0	0	0	0	0
0	0	0	1	0	0	0	1
0	0	1	0	0	0	1	1
0	0	1	1	0	0	1	0
0	1	0	0	0	1	1	0
0	1	0	1	0	1	1	1
0	1	1	0	0	1	0	1
0	1	1	1	0	1	0	0
1	0	0	0	1	1	0	0
1	0	0	1	1	1	0	1
1	0	1	0	1	1	1	1
1	0	1	1	1	1	1	0
1	1	0	0	1	0	1	0
1	1	0	1	1	0	1	1
1	1	1	0	1	0	0	1
1	1	1	1	1	0	0	0

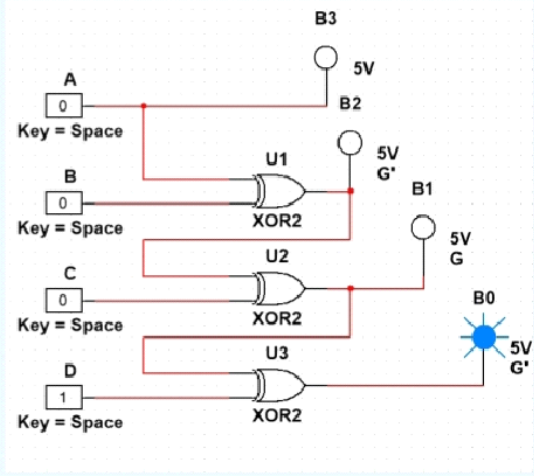
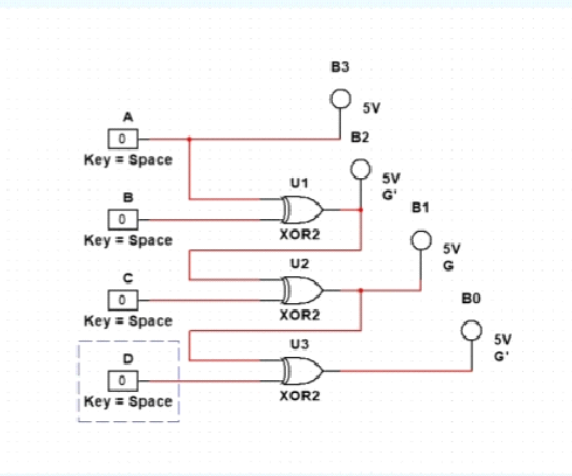

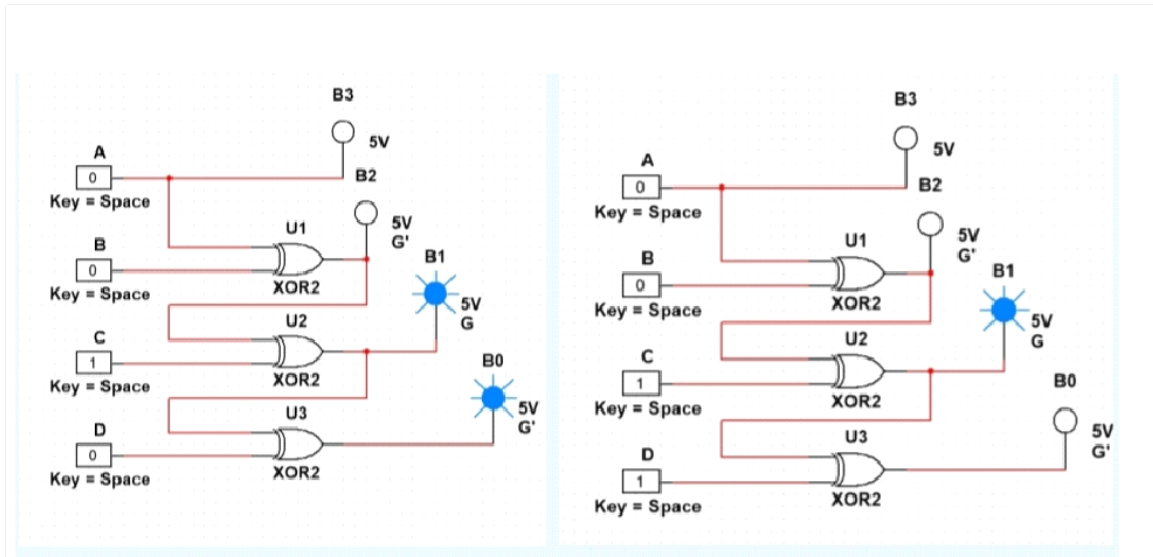

## RESULTS AND ANALYSIS:

*The gray to binary code converter is used since two systems using two different codes but they need to use the same information. Gray to binary code converter convert correctly gray 0000 to 1111 into binary codes. The circuit diagram is very simple and only uses an 74886 IC i.e. XOR gate. Unless the Karnaugh map is used many gates may be used. but result of Karnaugh map minimization, it can work only using XOR Gate. Gray code is a weighted, cyclic and reflective code are used in instrumentation and acquisition system where linear or angular displacement is measured, shaft encoders, I/O devices, A/D converters and outer peripheral devices.*

## CONCLUSION:

*The function table of Gray to Binary Code has been verified.*

