



Student Name: Ahmad zaib

ID: 13132

Subject: Industrial Electronics

Department: BE(E)

Semester: 8th

Teacher : Sir Sana Ullah Ahmad

Question No 1. A.

Consider a lubricating oil tank in Industrial Plant having 2 sensors, one is put near to the bottom and one near to top, to fill the tank, motor A will pump oil to tank until the high level sensor turns on, at that point the motor A turns OFF. Motor A is turned ON when the level fall below the low level sensor. Explain the states of PLC operating cycle with help of neat ladder diagrams.

Ans; For the process given below explain and draw ladder diagrams of each steps involved to control a lubricant tank in a plant.

•We are controlling lubricating oil being dispensed from a tank. This is possible by using two sensors. We put one near the bottom and one near the top, as shown in the picture below

•Here, we want the fill motor to pump lubricating oil into the tank until the high level sensor turns on. At that point we want to turn off the motor until the level falls below the low level sensor. Then we should turn on the fill motor and repeat the process.

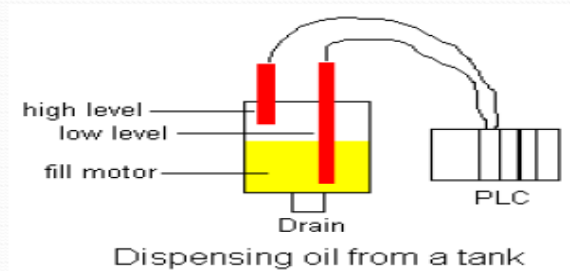

Low level sensor	0000
High level Sensor	0001

Output	Address
Motor	0500

Internal Utility Relay
1000

The Ladder Diagram

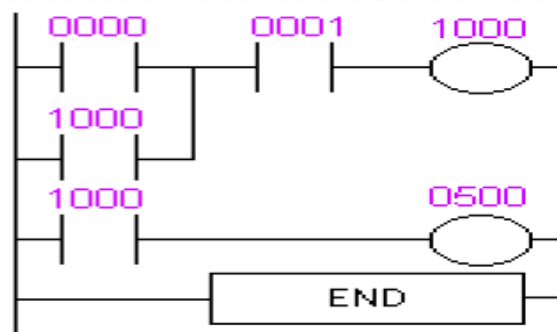

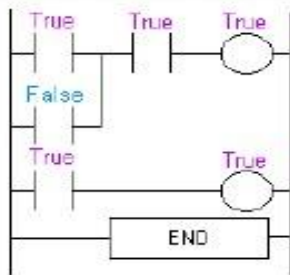

Scan 1

Initially the tank is empty. Therefore, input 0000 is TRUE and input 0001 is also TRUE

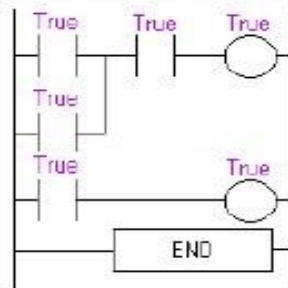

Scan 2

The internal relay is turned on as the water level rises.

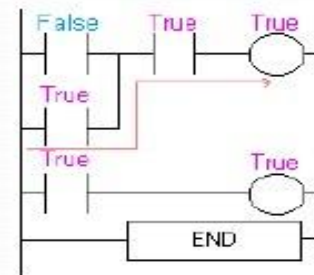

Scan 3

After scan 2 the oil level rises above the low level sensor and it becomes open. (i.e. FALSE)

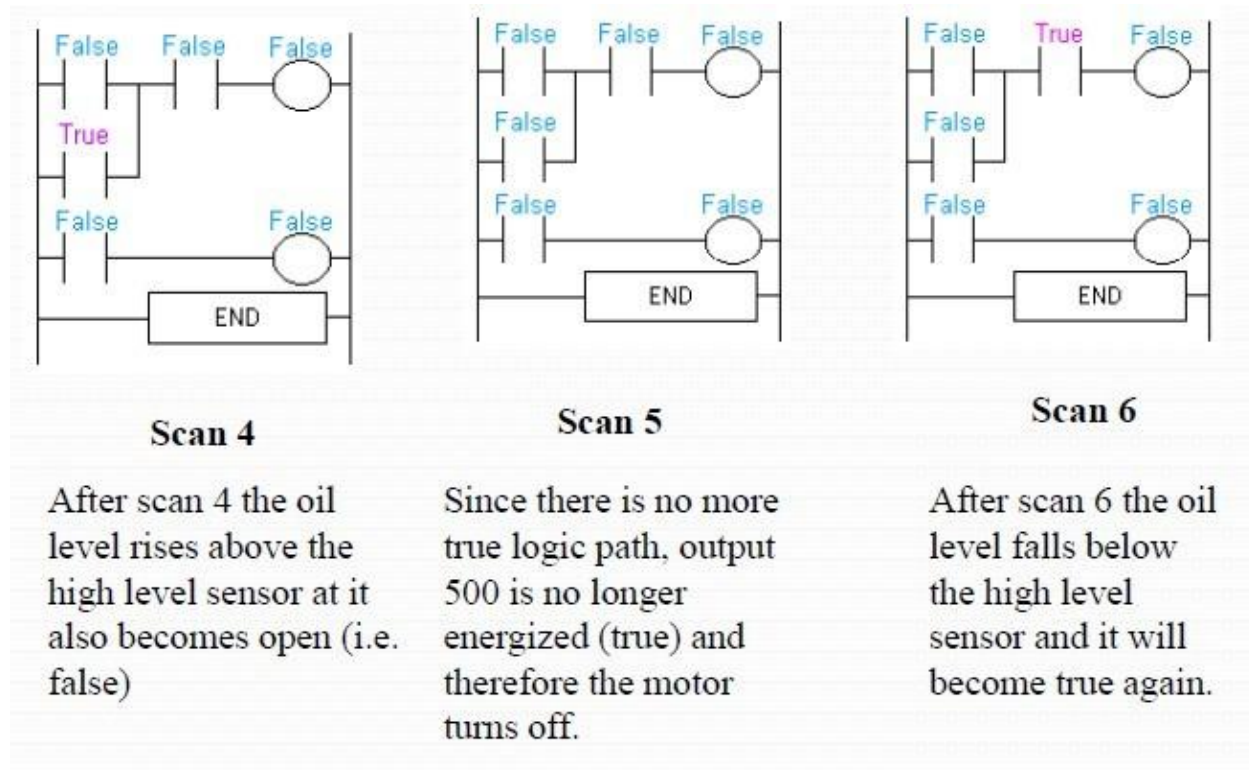

Q2(a). Write some benefits of industrial Automation

Ans;

Benefits of Industrial Automation

- **Increasing Productivity**

- Increased productivity = more units/day = more money

- **Products produced more consistently**

- increased consistency = higher quality = increased consumer satisfaction –

Example - A bottled soft drink such as a Coke or a Pepsi always tastes the same no matter where or when you purchase it. Consumers count on this.

- **Products produced more reliably**

– robots can run 24 hours/day without getting tired or bored

- **Decreased labor expenses**

– Automated systems reduce the amount of people needed to produce the goods

- **Increasing Safety in working conditions**

Q2(b)briefly explain the components and functions of SCADA system

Ans; Components of SCADA

There are many parts or **components of SCADA** system, which include hardware (input and output), controllers, networks, user interface, communications equipment and software.All together, the term SCADA refers to the entire central system. The central system usually monitors data from various sensors that are either in close proximity or off site (sometimes miles away).

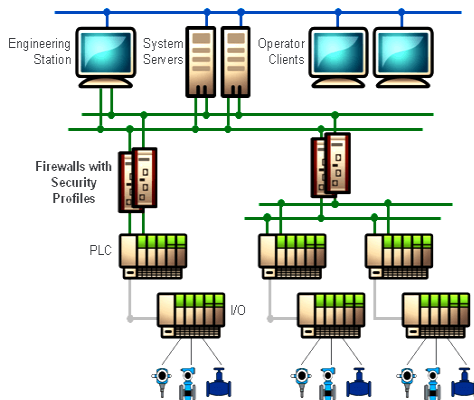

Functions of SCADA ;;A SCADA system performs four functions

1. Data acquisition
2. Networked data communication
3. Data presentation
4. Control

These functions are performed by four kinds of SCADA components :

1. **Sensors** (either digital or analog) and control relays that directly interface with the managed system.

2. **Remote telemetry units (RTUs).** These are small computerized units deployed in the field at specific sites and locations. RTUs serve as local collection points for gathering reports from sensors and delivering commands to control relays.
3. **SCADA master units.** These are larger computer consoles that serve as the central processor for the SCADA system. Master units provide a human interface to the system and automatically regulate the managed system in response to sensor inputs.
4. **The communications network** that connects the SCADA master unit to the RTUs in the field.

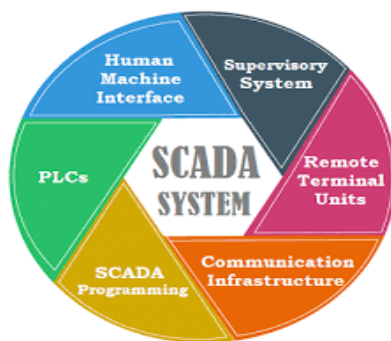

Q3(a) Differentiate between hardwired control system and PLC system

Ans;

Hardwired control systems

- The functions are determined by the physical wiring.
- Changing the function means changing the wiring.
- Can be contact-making type (relays, contactors) or electronic type (logic circuits)

PLC Systems

- The functions are determined by a program stored in the memory.
- The control functions can be changed simply by changing the program.
- Consist of a control device, to which all the sensors and actuators are connected.

Q3(b). What are the function of SCADA systems

Ans;

SCADA Functions

Centrally monitors and controls thousands of industrial equipment such as

- Motors, valves, pumps, relays, sensors, etc

Displays current state of remote process (visualization)

Displays alarms/Events log

