



Hassan Saad
 14286
 Sessional Assignment
 Instructor: Mam Aasma Khan
 Course: Business Process Engineering
 Date: May 10, 2020

- Attempt all questions.
- Marks will be given as per the DEPTH of the answer, not LENGTH.

Question No: 01 (10)

Compute Load Distance (LD) scores for the below given current and proposed designs and identify which design is the better one;

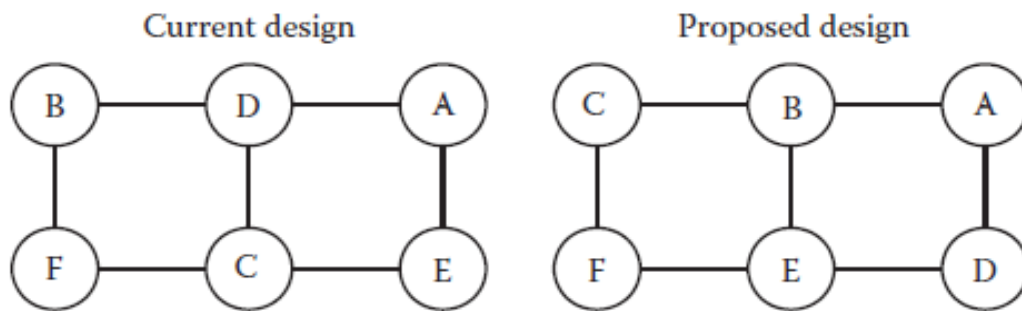

Figure 1 Two Designs

	A	B	C	D	E	F
A		20		20		80
B			10		75	
C				15		90
D					70	

Figure 2 Load Matrix

Answer: The LD score between work centers i and j is found as follows:

❖ $LD\ score(i, j) = Load(i, j) \times Distance(i, j)$

LD Calculation for Two Designs

Centers	Load	Current Design		Proposed Design	
		Distance	LD Score	Distance	LD Score
(A,B)	20	2	40	1	20
(A,D)	20	1	20	1	20
(A,F)	80	3	240	3	240
(B,C)	10	2	20	1	10
(B,E)	75	3	225	1	75
(C,D)	15	1	15	3	45
(C,F)	90	1	90	1	90
(D,E)	70	2	140	1	70
Total			790		570

Question No: 02

(10)

A process management team has studied a process and has developed the flowchart in Figure 3. The team also has determined that the expected waiting and processing times (in minutes) corresponding to each activity in the process are as shown in Table 1.

- i. Calculate the average CT for this process.

✚ **Average CT:** $10 + 10 \times 20 + 90 \times 24 + 25 + 15 \times (12 + 23 + 35) + 15 = 34.60$

- ii. Calculate the CT efficiency.

✚ **CT efficiency = Process Time / CT**

Process time = $12 + 10 \times 18 + 90 \times 30 + 17 + 1.15 \times (12 + 25 + 7) + 10 = 29.69$

CT efficiency = $34.60 / 29.69 = 1.17$

Activity	Waiting Time (Min)	Processing Time (Min)
A	20	12
B	15	18
C	5	30
D	12	17
E	3	12
F	5	25
G	8	7
H	5	10
I	15	25
J	5	20
K	4	10

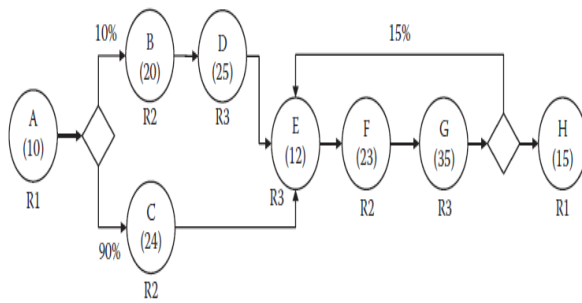

Figure 3 Process Flow Chart

Good Luck ☺