



NAME: AMIT SINGH

ID: 15478

SUBJECT: DIGITAL LOGIC DESIGN

SEMESTER: 3RD

PROGRAMME: BS (SOFTWARE ENGINEERING)

HALF ADDER

AIM: Design and verify the logic circuit of Half adder using logic gates.

OBJECTIVES: • To understand the principle of binary addition. • To understand half adder concept. • Use truth table and Boolean Algebra theorems in simplifying a circuit design. • To implement half adder circuit using logic gates

PROCEDURE: 1. collect the components necessary to accomplish this experiment. 2. Plug the IC chip into the breadboard. 3. Connect the supply voltage and ground lines to the chips. PIN7 = Ground and PIN14 = +5V. 4. According to the pin diagram of each IC mentioned above, make the connections according to circuit diagram. 5. Connect the inputs of the gate to the input switches of the LED. 6. Connect the output of the gate to the output LEDs. 7. Once all connections have been done, turn on the power switch of the bread-board 8. Operate the switches and fill in the truth table (Write "1" if LED is ON and "0" if LED is OFF Apply the various combination of inputs according to the truth table and observe the condition of Output LEDs.

HALF ADDER: Half Adder: A half adder is a logical circuit that performs an addition operation on two binary digits. The half adder produces a sum and a carry value which are both binary digits.

OBSERVATION TABLE:

A	B	SUM (S)	Carry (C)
0	0	0	0
0	1	1	0
1	0	1	0
1	1	0	1

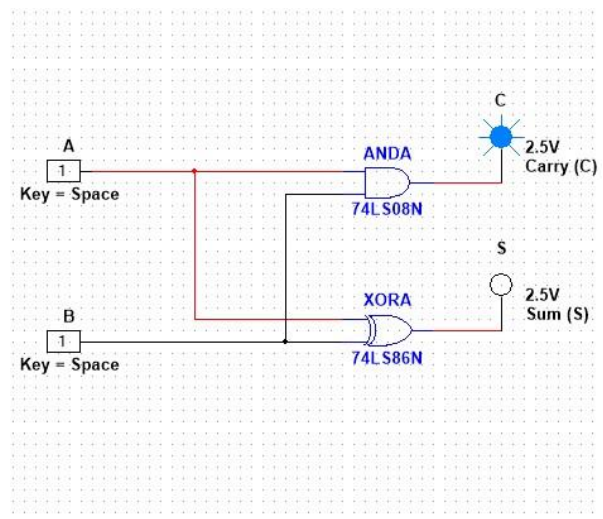
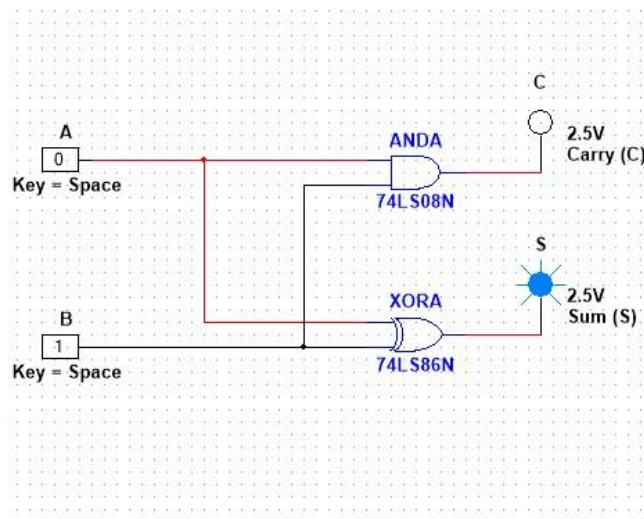
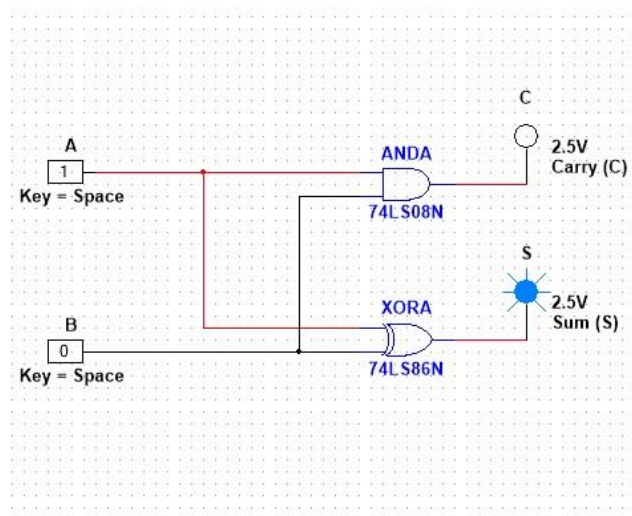
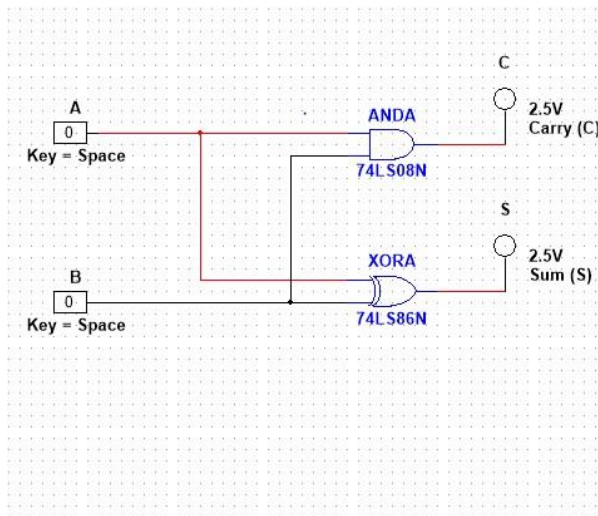

RESULTS AND ANALYSIS: Half Adder: Verified the truth table of Half Adder as $S = 1$ i.e. LED which is connected to S terminal glows when

inputs are A, B Verified the truth table of Half-Adder as $C = 1$ i.e. LED which is connected to C terminal glows when inputs are A, B.

CONCLUSION: • To add two bits we require one XOR gate(IC 7486) to generate Sum and one AND (IC 7408) to generate carry. • To add three bits we require two half adders.