

Name Muhammad ilyas

Id no 15392

Assignment lab

Degree BS (software engineering)

Teacher sir M.amin

JK FLIP FLOP

AIM:

To Design and verify the truth table of J K Flip flop using IC 7473.

OBJECTIVES:

- To understand the principle of operation of sequential circuit
- To differentiate between combinational circuit and sequential circuit
- To get familiar with basic Flip flops
- Determine the logic operation of JK flip flops.
- Connect and observe the state transition of JK as connected to the clock generator circuit.

PROCEDURE:

- Collect the components necessary to accomplish this experiment.
- Plug the IC chip into the breadboard.
- Connect the supply voltage and ground lines to the chips. PIN7 = Ground and PIN14 = +5V
- According to the pin diagram of each IC mentioned above, make the connections according to circuit diagram.
- Connect the inputs of the gate to the input switches of the LED.
- Connect the output of the gate to the output LEDs.
- Once all connections have been done, turn on the power switch of the breadboard

- Operate the switches and fill in the truth table (Write "1" if LED is ON and "0" if LED is OFF Apply the various combination of inputs according to the truth table and observe the condition of Output LEDs.

JK FLIP FLOP:

A flip-flop is a circuit that has two stable states and can be used to store state information. The circuit can be made to change state by signals applied to one or more control inputs and will have one or two outputs

CK	J	K	Q	Q _̄
1	0	0	-	-
1	0	1	0	1
1	1	0	1	0
1	1	1	0	1

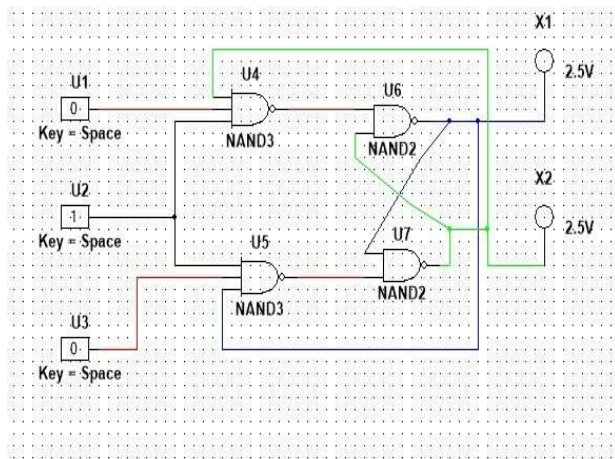

RESULTS AND ANALYSIS:

Flip-flops (FFs) are devices used in the digital field for a variety of purposes. Flipflops are a fundamental building block of digital electronics systems used in computers, communications, and many other types of systems. In JK flip - flop, the letter J is for set and the letter K is for clear. When logic 1 inputs are applied to both J and K simultaneously, the flip-flop switches to its complement state, i.e., if Q=1, it switches to Q=0 and vice versa. Flip-flops and latches are used as data storage elements. Such data storage can be used for storage of state, and such a circuit is described as sequential logic. When used in a finite-state machine, the output and next state depend not only on its current input, but also on its current

state (and hence, previous inputs.) It can also be used for counting of pulses, and for synchronizing variably -timed input signals to some reference timing signal.

CONCLUSION:

The function table of JK flip flop using IC 7473 has been verified.