

Name : **irfan ullah**

ID : **15431**

LAB : **no 1**

Subject : **Digital Logic Design**

Course code(CS): **CSC-201**

Program : **BC (CS)**

VERIFICATION OF GATES

AIM:

To study and verify the Truth Tables of AND, OR, NOT, NAND, NOR, XOR, XNOR logic gates for positive logic.

OBJECTIVES:

- To get familiar with the usage of the available lab equipment.
- To get familiar with Prototyping board (breadboard)
- To describe and verify the operation for the AND, OR, NOT, NAND, NOR, XOR, XNOR gates.
- To study the representation of these functions by truth tables, logic diagrams and Boolean algebra
- To Introduce a basic knowledge in integrated circuit devices operation
- To practice how to build a simple digital circuit using ICs and other digital

PROCEDURE:

1. Collect the components necessary to accomplish this experiment.
2. Plug the IC chip into the breadboard.
3. Connect the supply voltage and ground lines to the chips. PIN7 = Ground and PIN14 = +5V.
4. According to the pin diagram of each IC mentioned above, wire only one gate to verify its truth table.
5. Connect the inputs of the gate to the input switches of the LED.
6. Connect the output of the gate to the output LEDs.
7. Once all connections have been done, turn on the power switch of the bread- board
8. Operate the switches and fill in the truth table (Write "1" if LED is ON and "0" if LED is OFF
Apply the various combination of inputs according to the truth table and observe the condition of Output LEDs.
9. Repeat the above steps 1 to 5 for all the ICs.

AND-GATE:

A multi-input circuit in which the output is 1 only if all inputs are 1. The symbolic representation of the AND gate is:

A dot (.) is used to show the AND operation i.e. A.B if A and B are the inputs to AND Gate.

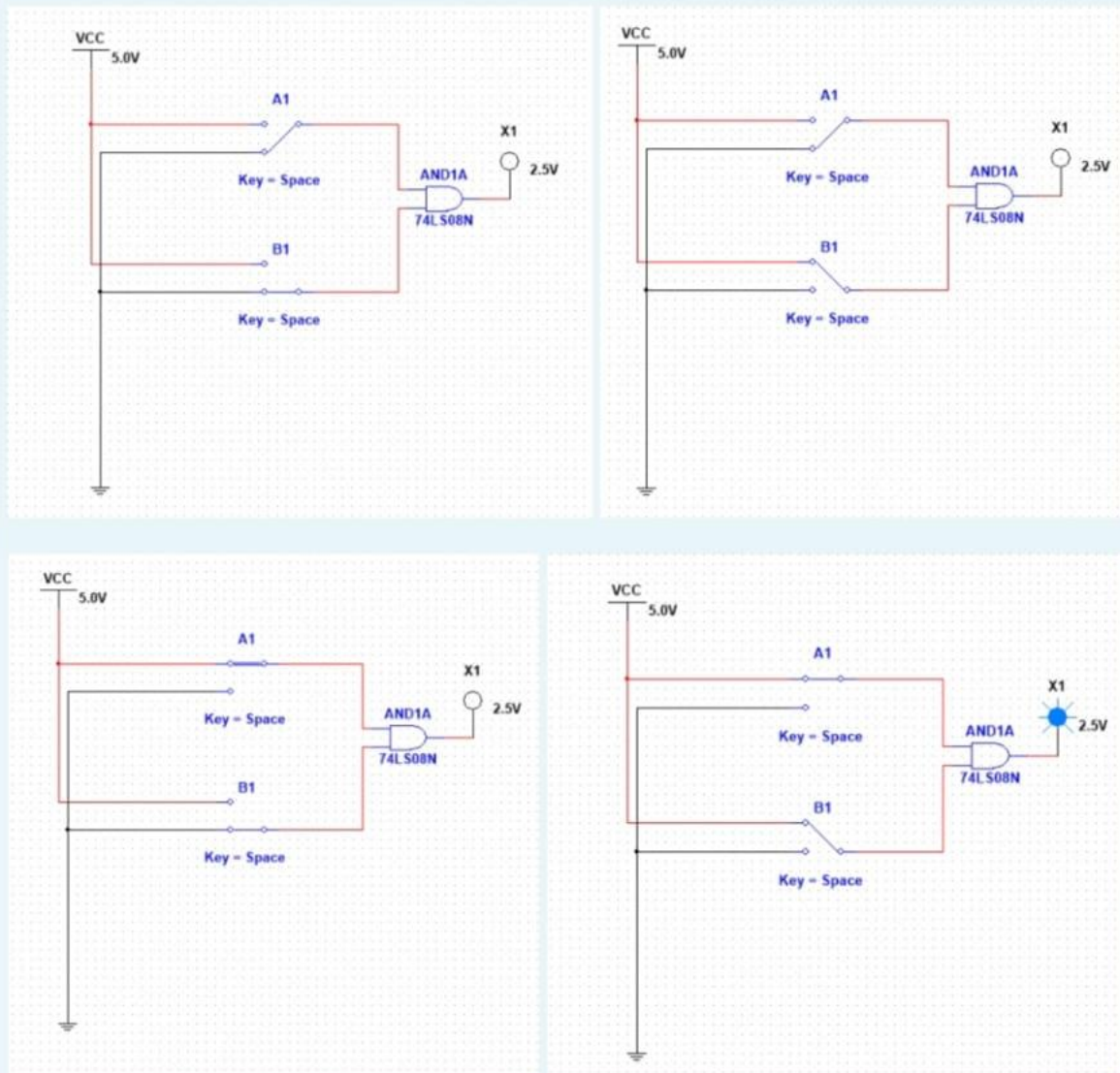

A	B	Output
0	0	0
0	1	0
1	0	0
1	1	1

NAND-GATE:

A multi-input circuit in which the output is 0 only if all inputs are 1.

A dot (· With Bar on the Letter) is used to show the NAND operation i.e. $\overline{A \cdot B}$ if \overline{A} and \overline{B} are the inputs to NAND Gate.

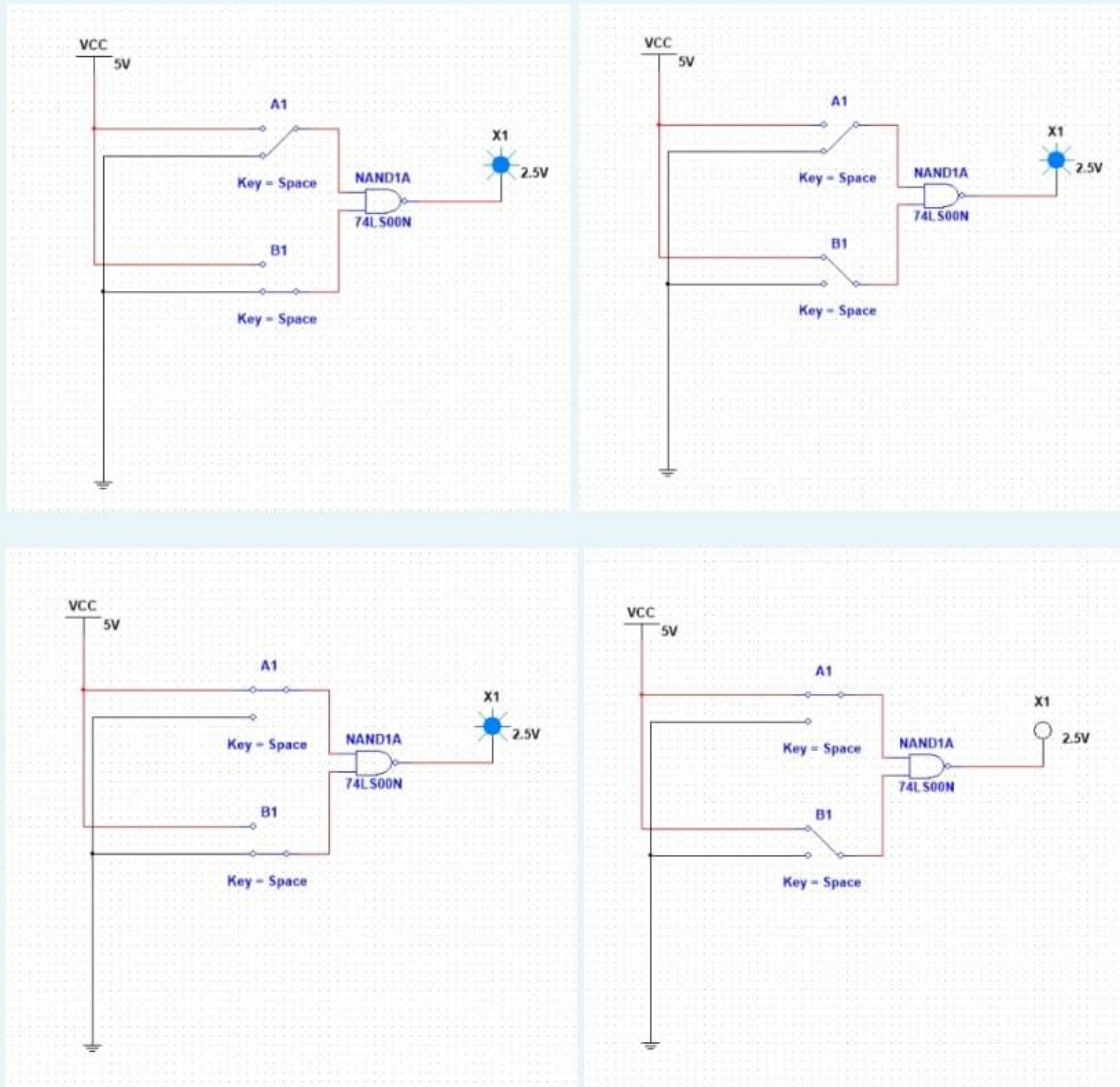

A	B	Output
0	0	1
0	1	1
1	0	1
1	1	0

OR-GATE:

The OR gate is an electronic circuit that gives a high output (1) if one or more of its inputs are high. A plus (+) is used to show the OR operation.

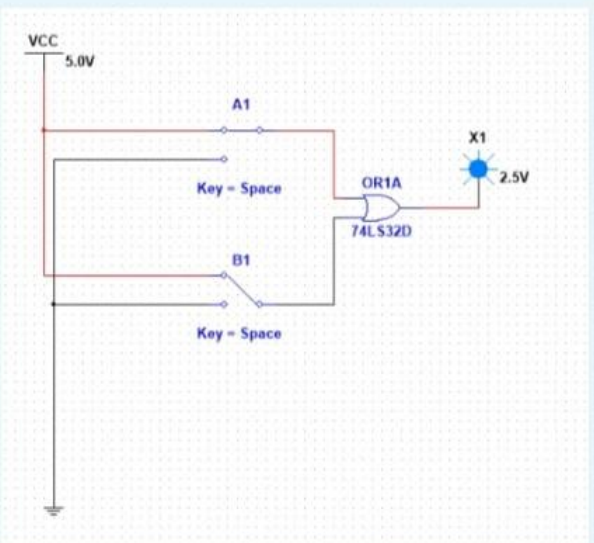
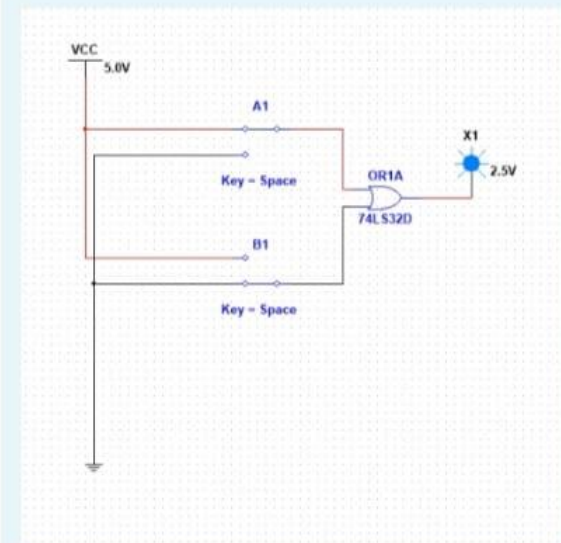
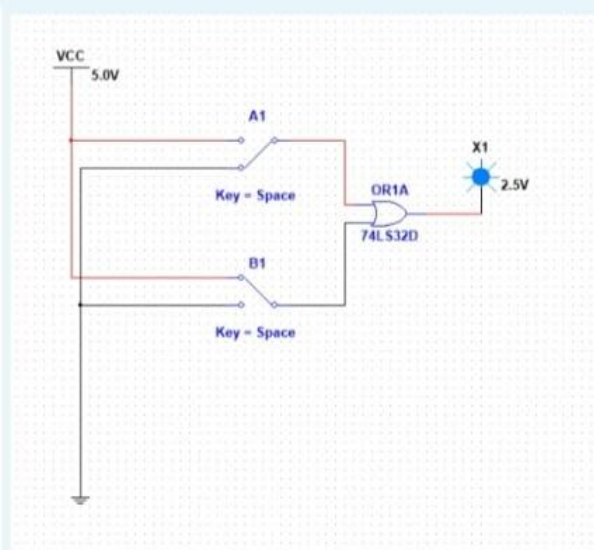
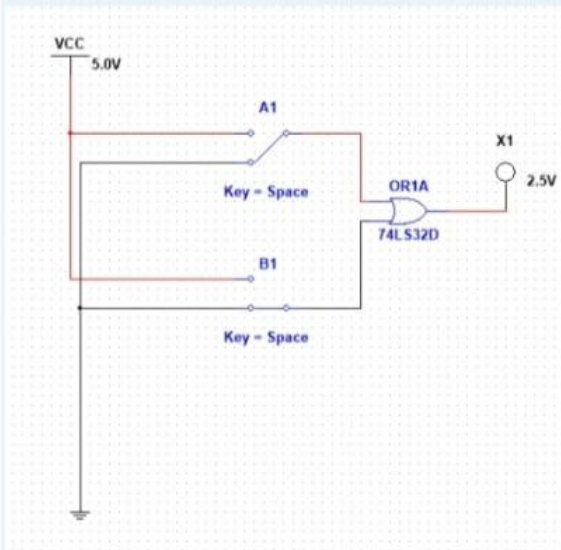

A	B	Output
0	0	0
0	1	1
1	0	1
1	1	1

NOR-GATE:

The NOR gate is an electronic circuit that gives a high output (o) if one or more of its inputs are high. A plus (+ with a bar on the letter) is used to show the NOR operation.

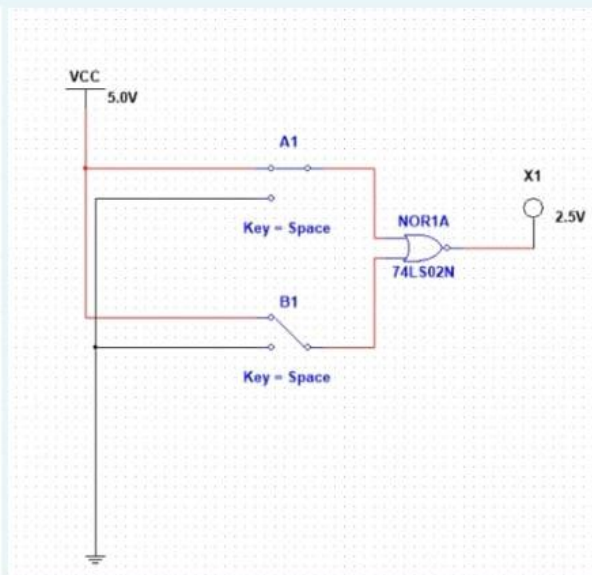
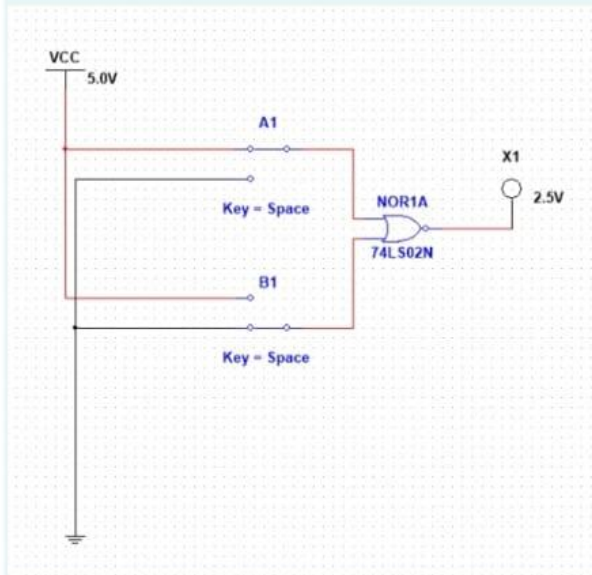
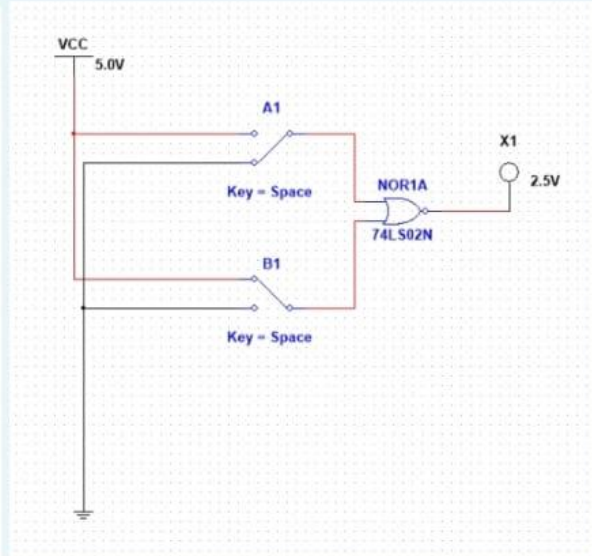
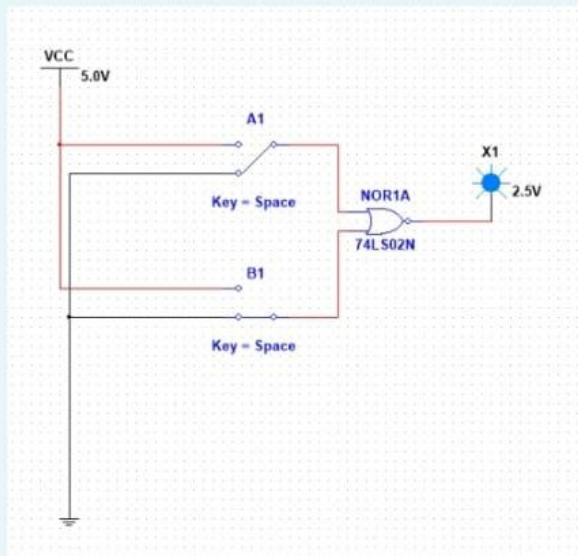

A	B	Output
0	0	1
0	1	0
1	0	0
1	1	0

NOT-GATE:

The NOT gate is an electronic circuit that produces an inverted version of the input at its output. It is also known as an inverter. If the input variable is A, the inverted output is known as NOT A. This is also shown as A', or A with a bar over the top, as shown at the outputs

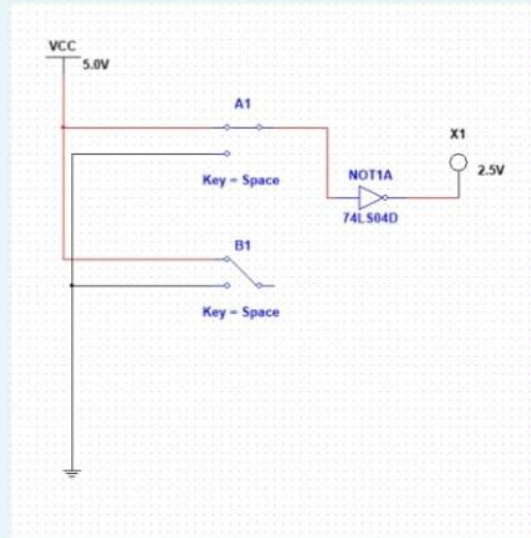
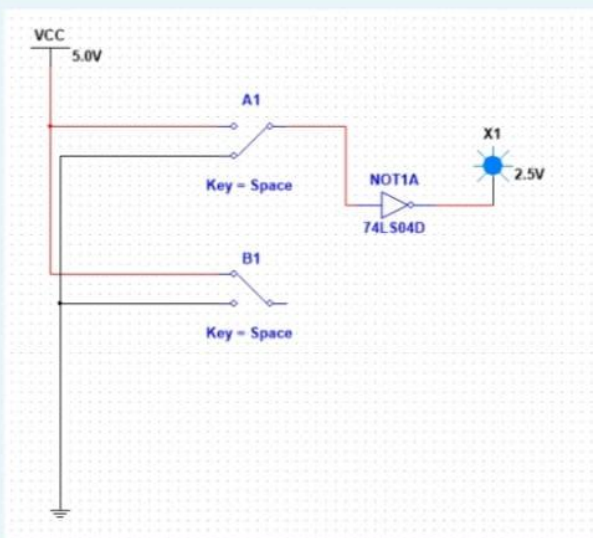

A	Output
0	1
1	0

XOR-GATE:

The 'Exclusive-OR' gate is a circuit which will give a high output if either, but not both, of its two inputs are high. An encircled plus sign (\oplus) is used to show the XOR operation.

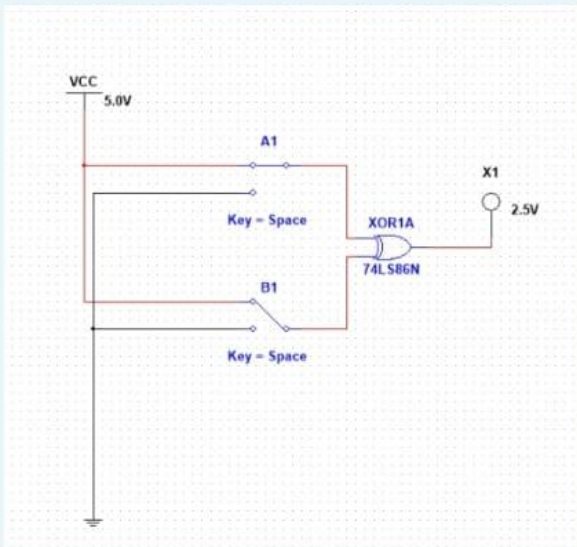
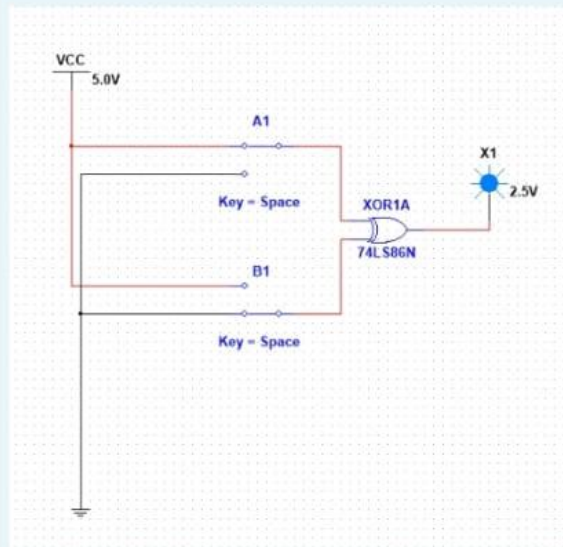
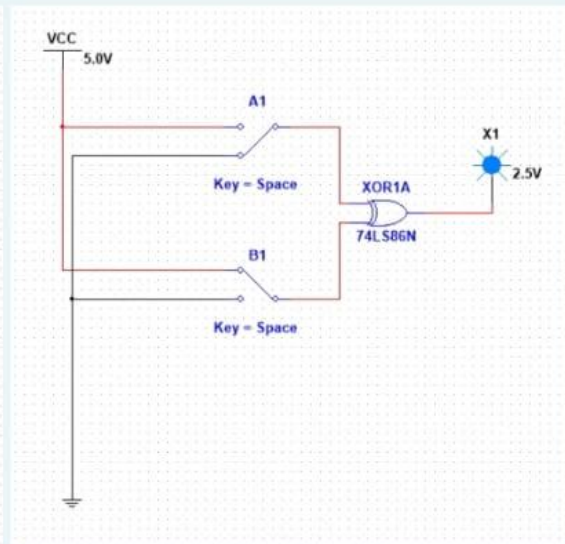
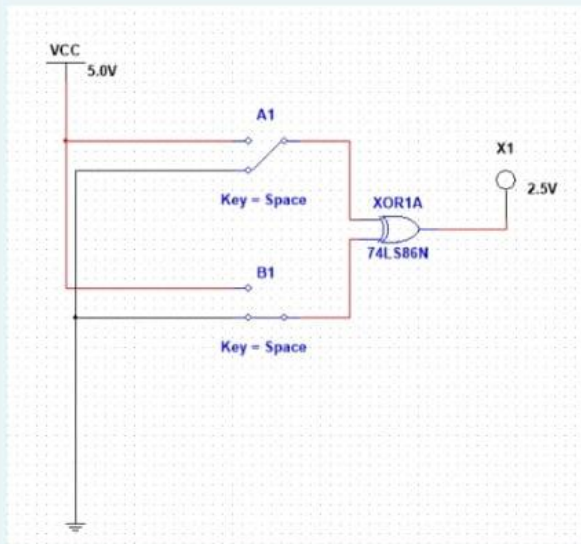

A	B	Output
0	0	0
0	1	1
1	0	1
1	1	0

XNOR-GATE:

The XNOR gate is a digital logic gate whose function is the inverse of the operation exclusive OR (XOR) gate. The output of the Exclusive NOR gate, is 0 when its two inputs are the different and its output is 1 when its two inputs are same. An encircled plus sign and bar are used to show the XNOR operation.

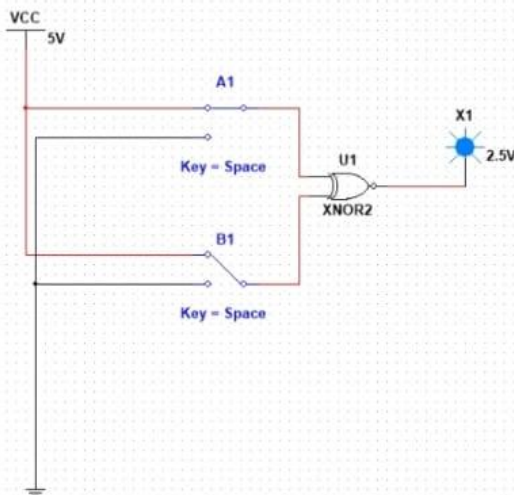
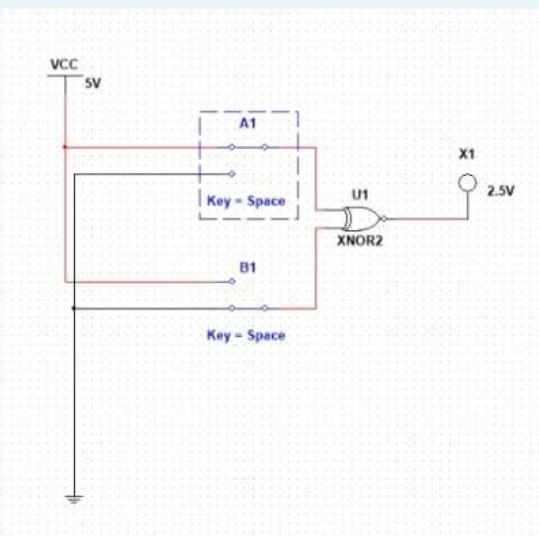
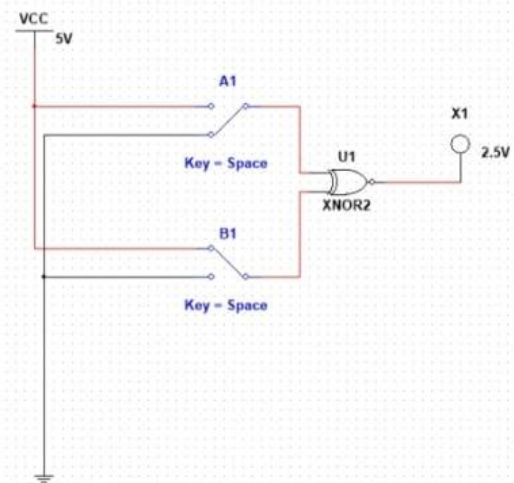
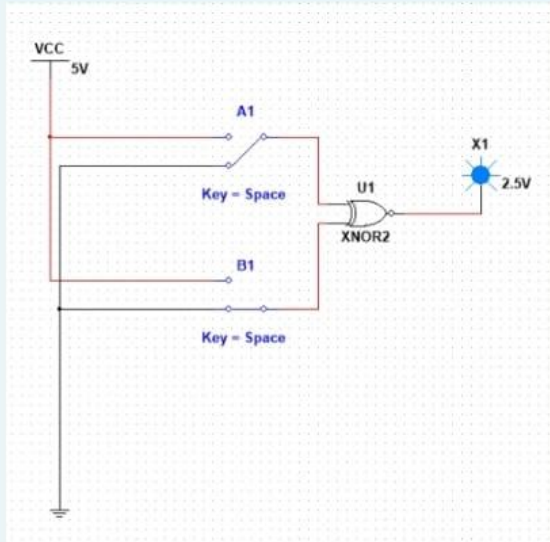

A	B	Output
0	0	1
0	1	0
1	0	0
1	1	1

OUTPUT OBSERVATION TABLE:

S.no	Inputs		Outputs						
	A	B	NOT	AND	OR	NAND	NOR	XOR	XNOR
1	0	0		0	0	1	1	0	1
2	0	1		0	1	1	0	1	0
3	1	0		0	1	1	0	1	0
4	1	1		1	1	0	0	0	1

- OR Gate: The output of an OR gate is a 1 if one or the other or both of the inputs are 1, but a 0 if both inputs are 0. When One or the other or Both of the input LEDs are ON (RED Light), then output LED is ON (RED) otherwise Output LED is OFF (Green Light)
- AND Gate: The output of an AND gate is only 1 if both its inputs are 1. For all other possible inputs, the output is 0. When both the LEDs are On, then output LED is ON (RED Light) otherwise Output LED is OFF.
- NOR Gate: The output of the NOR gate is a 1 if both inputs are 0 but a 0 if one or the other or both the inputs are 1. NAND Gate: The output of the NAND gate is a 0 if both inputs are 1 but a 1 if one or the other or both the inputs are 0.
- XOR gate: The output of the XOR gate is a 1 if either but not both inputs are 1 and a 0 if the inputs are both 0 or both 1.
- XNOR gate: The output of the Exclusive NOR gate, is 0 when its two inputs

are the different and its output is 1 when its two inputs are same.

CONCLUSION:

Any Boolean expression can be realized using NOT, AND, OR, NAND, NOR, XOR, XNOR gates.