

Department of Electrical Engineering

Assignment

Date: 26/06/2020

Course Details

Course Title: Electric Power Distribution and Utilization
Instructor: ENGR WALEED JAN

Module: 4th (B Tech)
Total Marks: 50

Student Details

Name: AZHAD NIAZ

Student ID: 15493

Note: Draw neat diagram where necessary. Assume missing details if required.

Q1.	A DC distributor XY, which is 2 wired, 500m long, is fed from both ends at 230V. Various loads of 10 A, 40 A, 30 A and 40 A are tapped at distances of 100m, 250m, 350m and 450 m from the end X respectively. If the area of cross-section of distributor conductor is 2cm^2 , find the minimum consumer voltage. Take the value of resistivity $1.5 \times 10^{-5} \Omega \text{ cm}$	Marks 10
Q2.	A DC distributor AB, which is 2 wired, 3km long, supplies loads of 150A, 200A, 250A and 100A situated 500 m, 1300 m, 2300 m and 3000 m from the supply point A. The resistance of each conductor is 0.02Ω per 1000 m. Calculate the potential difference at each load point if a p.d. of 400 V is maintained at point A.	Marks 10
Q3.	A D.C. distribution system, which is 3-wired, is supplying a load of 7Ω resistance across the positive outer and neutral and a load of 9Ω resistance across negative outer and neutral at the far end of the distributor. The resistance of each conductor is 0.2Ω . If the voltage between any outer and neutral at the load end is to be kept at 260 V, find the voltages at the feeding end.	Marks 10
Q4.	(a) What will happen if the insulating material used for underground cable is hygroscopic and has low dielectric strength?	Marks 05
	(b) Pure rubber cannot be used as an insulating material for underground cable. Justify this statement.	Marks 05
Q5.	(a) In Direct laying method of underground cable, the maintenance cost is high. Justify this statement.	Marks 05
	(b) The Solid system used for laying of underground cable is expensive as compared to direct laid system. Justify this statement.	Marks 05

Student Details

Name: AZHAD NIAZ

Student ID: 15493

Q1: A DC distributor XY, which is 2 wired, 500m long, is fed from both ends at 230V. Various loads of 10 A, 40 A, 30 A and 40 A are tapped at distances of 100m, 250m, 350m and 450 m from the end X respectively. If the area of cross-section of distributor conductor is 2cm^2 , find the minimum consumer voltage. Take the value of resistivity $1.5 \times 10^{-5} \Omega \text{ cm}$

SOLUTION:

Resistance of 1m length of distributor

$$= 2 \times \frac{1.5 \times 10^{-5} \times 100}{1} = 3 \times 10^{-3}$$

Resistance of section = AC, $R_{ac} = (3 \times 10^{-3})100 = 0.3\Omega$

Resistance of section = CD, $R_{cd} = (3 \times 10^{-3})150 = 0.4\Omega$

Resistance of section = DE, $R_{de} = (3 \times 10^{-3})100 = 0.3\Omega$

Resistance of section = EF, $R_{ef} = (3 \times 10^{-3})100 = 0.3\Omega$

Resistance of section = FB, $R_{fb} = (3 \times 10^{-3})100 = 0.3\Omega$

Voltage at Y = voltage at X – drop over length XY

$$V_Y = [V_X - I_A R_{AC} + (I_A - 20)R_{CD} + (I_A - 60)R_{DE} + (I_A - 110)R_{EF} + (I_A - 140)R_{FB}]$$

$$230 = 230 - [0.3I_A + 0.4(I_A - 20) + 0.3(I_A - 60) + 0.3(I_A - 110) + 0.3(I_A - 140)]$$

$$= 230 - (1.6I_A - 12.58)$$

Or $1.6I_A = 12.58$

$$I_A = 12.58 / -1.6 = 7.862\text{A}$$

Knowing the value of

I_A current in any section can be determined. thus current in section Cd, $I_{CD} = I_A - 20 = 7.862 - 20 = -12.138\text{A}$ from C to D

$$I_{DE} = I_A - 60 = 7.862 - 60 = -52.138\text{A} \text{ from D to E}$$

Current in section EF, $I_{EF} = I_A - 110 = 7.862 - 110 = -102.138\text{A}$ from E to F

Student Details

Name: AZHAD NIAZ

Student ID: 15493

Current in section FB, $I_{FB} = I_A - 140 = 7.862 - 140 = -132.138A$ From F to B

The actual distribution of currents in the various sections of the distributors

It is clear that current are coming to the load point E from both sides i.e From D

∴ Minimum consumer voltage

$$\begin{aligned} V_E &= V_A - (I_{AC}R_{AC} + I_{CD}R_{Cd} + I_{DE}R_{DE}) \\ &= 230 - (7.682 \times 0.3 + 7.862 \times 0.4 + 7.862 \times 0.3) \\ &= 230 - 7.682 \\ &= -222.318V \end{aligned}$$

Question 2

Supply load is 150A , 200A , 250 A ,100A dIstance of 500m ,1300m ,2300m ,3000m .

The resistance of each conductor is $R = 0.02$ per 100m

Potential difference of point A =400V

Required data:

Potential difference of each load =?

Solution:

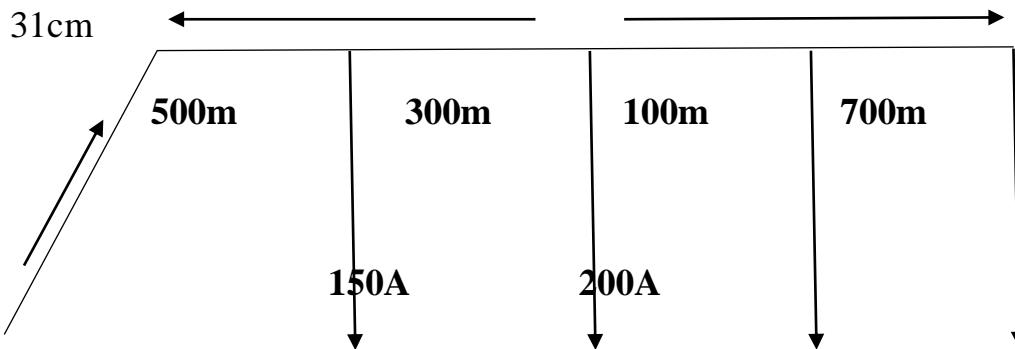

The single line diagram of with its topped is = $2 \times 0.02\Omega$

Student Details

Name: AZHAD NIAZ

Student ID: 15493

Resistance of section A_C, R_{AC}

$$A_C, R_{AC} = 0.04 \times 500 / 1000$$

$$= 0.04 \times 0.5$$

$$A_C, R_{AC} = 0.02 \Omega$$

Resistance of section A_{CP}, R_{ACD}

$$C_D, R_{CD} = 0.04 \times 200 / 1000$$

$$C_D, R_{CD} = 0.032 \Omega$$

Resistance of section D_E, R_{DE}

$$D_E, R_{DE} = 0.04 \times 1000 / 1000$$

$$= 0.04 \times 1$$

$$D_E, R_{DE} = 0.04 \Omega$$

Resistance of section

$$E_B, R_{EB} = 0.04 \times 700 / 1000$$

$$= 0.04 \times 0.7$$

$$E_B, R_{EB} = 0.28 \Omega$$

Student Details

Name: AZHAD NIAZ

Student ID: 15493

The current and the various section of distributor are

$$I_{EB} = 100A$$

$$I_{DE} = 100 + 250 = 350A$$

$$I_{CD} = 350 + 200$$

$$= 550A$$

$$I_{AC} = 550 + 150$$

$$= 700A$$

❖ Potential difference at point C = ?

❖

V_C = Voltage at A – Voltage drop in A.C

$$= V_A - I_{AC} \cdot R_{AC}$$

$$= 400 - 700 \times 0.02$$

$$= 400 - 14$$

$$V_C = 386V$$

Potential difference at point D = ?

$$V_D = V_C - I_{CD} \cdot R_{CD}$$

$$= 386 - 550 \times 0.032$$

$$= 386 - 17.6$$

$$= 368.4V$$

$$V_D = 368.4V$$

Student Details

Name: AZHAD NIAZ

Student ID: 15493

Potential difference at point E = ?

$$V_E = V_D - I_{DE} \cdot R_D$$

$$= 368.4 - 350 \times 0.04$$

$$= 368.4 - 14$$

$$= 354.4V$$

$$V_E = 354.4V$$

Potential difference at load point B = ?

$$V_B = V_E - I_{EB} \cdot R_{EB}$$

$$= 354.4 - 100 \times 0.028$$

$$= 354.4 - 2.8$$

$$= 351.6V$$

$$V_B = 351.6V$$

Ans.,

Student Details

Name: AZHAD NIAZ

Student ID: 15493

Q3: A D.C. distribution system, which is 3-wired, is supplying a load of $7\ \Omega$ resistance across the positive outer and neutral and a load of $9\ \Omega$ resistance across negative outer and neutral at the far end of the distributor. The resistance of each conductor is $0.2\ \Omega$. If the voltage between any outer and neutral at the load end is to be kept at $260\ \text{V}$, find the voltages at the feeding end.

SOLUTION:

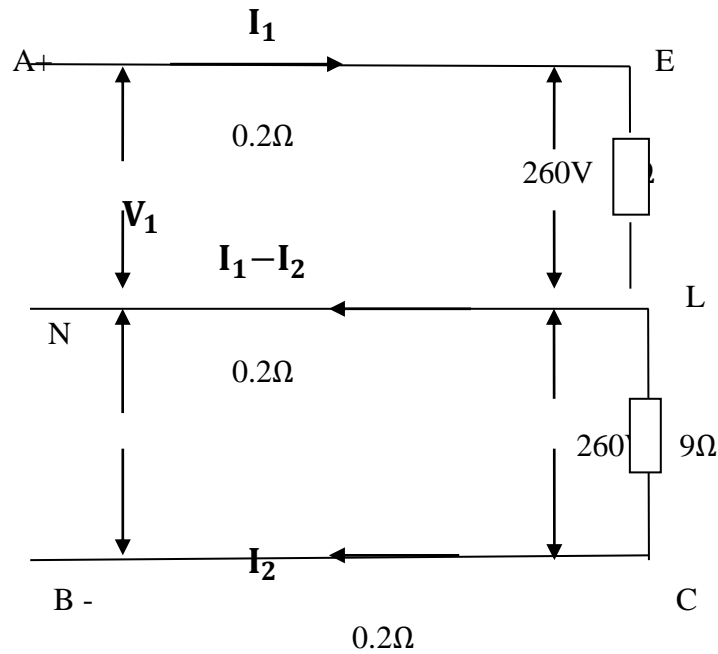

The above figure shows the 3 wire distributor system

$$\text{Current on +ve outer } I_1 = 260/7 = 37.14\text{A}$$

$$\text{Current on -ive outer } I_2 = 260/9 = 28.88\text{A}$$

$$\text{Current in neutral} = I_1 - I_2 = 37.14 - 28.88 = 8.26\text{A}$$

Voltage between +ve outer and neutral at feeding end is

$$\begin{aligned} V_1 &= V_{EL} + I_1 R_{AE} + (I_1 - I_2) R_{NL} \\ &= 260 + 37.14 \times 0.2 + 8.26 \times 0.2 = 269.08\text{V} \end{aligned}$$

Voltage between -ve outer and neutral at feeding end is

$$\begin{aligned} V_2 &= V_{LC} - (I_1 - I_2) R_{NL} + I_2 \\ &= 260 - 8.26 \times 0.2 + 28.88 \times 0.2 = 267.42\text{V} \end{aligned}$$

Student Details

Name: AZHAD NIAZ

Student ID: 15493

Q4

(A): What will happen if the insulating material used for underground cable is hygroscopic and has low dielectric strength?

ANS:

Insulating materials used in Underground cables

the Insulating materials used in underground cables. like what type of material is used , where they are laid ,what are the protective measures etc..Lets us start now. The satisfactory operation of a cable depends to a great extent upon the characteristics of insulation used. Therefore, the proper choice of insulating material for cables is of considerable importance. The insulating materials should have the following properties:

- (i) High insulation resistance to avoid leakage current.
- (ii) High dielectric strength to avoid electrical breakdown of the cable.
- (iii) High mechanical strength to withstand the mechanical handling of underground cables.
- (iv) Non-hygroscopic i.e., it should not absorb moisture from air or soil. The moisture tends to decrease the insulation resistance and hastens the breakdown of the cable. In case the insulating material is hygroscopic, it must be enclosed in a waterproof covering like lead sheath.
- (v) Non-inflammable.

(B) Pure rubber cannot be used as an insulating material for underground cable. Justify this statement.

ANS:

Rubber :

Rubber may be obtained from milky sap of tropical trees or it may be produced from oil products.

It has relative permittivity varying between 2 and 3, dielectric strength is about 30 kV/mm and resistivity of insulation is $10^{17}\Omega$ cm.

Although pure rubber has reasonably high insulating properties, it suffers from some major drawbacks. Readily absorbs moisture, maximum safe temperature is low (about 38°C), soft and liable to damage due to rough handling and ages when exposed to light.

Therefore, pure rubber cannot be used as an insulating material in underground cables.

Student Details

Name: AZHAD NIAZ

Student ID: 15493

Q5:

(a) In Direct laying method of underground cable, the maintenance cost is high. Justify this statement.

ANS:

This method is the most popular as it is simple and cheap. The cables to be laid using this method must have the serving of bituminized paper and hessian tape so as to provide protection against corrosion and electrolysis.

The direct laying procedure is as follows.

- A trench of about 1.5 meters deep and 45 cm wide is dug.
- Then the trench is covered with a 10 cm thick layer of fine sand.
- The cable is laid over the sand bed. The sand bed protects the cable from the moisture from the ground.
- Then the laid cable is again covered with a layer of sand of about 10 cm thick.
- The trench is then covered with bricks and soil to protect the cable from mechanical injury.

Advantages

- Simpler and cheaper than the other two methods
- Heat generated in cables is easily dissipated in the ground.

Disadvantages

- To install new cables for fulfilling an increased load demand, completely new excavation has to be done which costs as much as the new installation.
- Alterations in the cable network are not easy.
- Maintenance cost is higher.
- Identifying the location of a fault is difficult.
- This method can not be used in congested areas such as metro cities where excavation is too expensive.

(B) The Solid system used for laying of underground cable is expensive as compared to direct laid system. Justify this statement.

ANS:

The solid system of cable laying is mainly performed where the cable is laid in the wood, cast iron, or another nonoil surface.

Normally cable is laid in the manner which provides good mechanical strength to cables. This system is much appropriate for solid based systems.

Normally the cables are filled with bituminous materials for providing protection and avoid heat dissipation. Then another Asphalt cover layer around the cable and bituminous material area for further protection.

The system is expensive compare to the direct laid system and heat dissipation capacity is not much good compere with other systems. But for toughing material woods are much cheap so it is widely used by considering the economical impacts.