

Nicholas Anthony John Hastings

Physical Asset Management

With an Introduction to ISO55000

Second Edition

 Springer

Physical Asset Management

Nicholas Anthony John Hastings

Physical Asset Management

With an Introduction to ISO55000

Second Edition



Springer

Nicholas Anthony John Hastings
Wellington Point
QLD
Australia

ISBN 978-3-319-14776-5 ISBN 978-3-319-14777-2 (eBook)
DOI 10.1007/978-3-319-14777-2

Library of Congress Control Number: 2015930003

Springer Cham Heidelberg New York Dordrecht London
© Springer International Publishing Switzerland 2010, 2015

This work is subject to copyright. All rights are reserved by the Publisher, whether the whole or part of the material is concerned, specifically the rights of translation, reprinting, reuse of illustrations, recitation, broadcasting, reproduction on microfilms or in any other physical way, and transmission or information storage and retrieval, electronic adaptation, computer software, or by similar or dissimilar methodology now known or hereafter developed.

The use of general descriptive names, registered names, trademarks, service marks, etc. in this publication does not imply, even in the absence of a specific statement, that such names are exempt from the relevant protective laws and regulations and therefore free for general use.

The publisher, the authors and the editors are safe to assume that the advice and information in this book are believed to be true and accurate at the date of publication. Neither the publisher nor the authors or the editors give a warranty, express or implied, with respect to the material contained herein or for any errors or omissions that may have been made.

Printed on acid-free paper

Springer International Publishing AG Switzerland is part of Springer Science+Business Media
(www.springer.com)

Acknowledgments

Thanks are due to the many colleagues with whom I have worked over the years. These include Andrew Jardine, Melinda Hodkiewicz, Joseph Mathew, Tony Healy, Fred Stapelberg, Ray Beebe, Will Scott, Ernst Krauss, Subhash Sharma, and Len Bradshaw, publisher of the *Asset and Maintenance Management Journal*. These contacts have in many cases combined university research and teaching with industrial project work, and particularly with developing and delivering short training courses. These courses and projects have provided a two-way interchange of information with industry which has substantially shaped the present book.

Over the years I have enjoyed working with and participating in the activities of what was once called the Maintenance Engineering Society of Australia and is now called the Asset Management Council. Its members and former members include Peter Robinson, Sally Nugent, Jim Kennedy, Peter Kohler, Roger Byrne, and Gary Winsor, among many others. The same applies to members of the International Forum for Research in Maintenance whose members and former members include Bill Gerrards, Tony Christer, Jasper Coetzee, Harry Martin, and David Sherwin.

Maintenance engineering and asset management research and education at Queensland University of Technology have been sponsored at various times by Mount Isa Mines Ltd., by the Queensland Electricity Supply Industry, and by the Cooperative Research Centre in Integrated Engineering Asset Management.

There is a vast amount of organizational documentation in this field. This includes the ISO55000 and IEC 60300 series standards, and the American Petroleum Institute publications. On the other hand there are relatively few conventional books. I am reminded of a joke that I heard on the radio... A teacher told her students to write an essay on a subject of their own choosing. A boy submitted an essay called, "My Dog". Having read it, the teacher handed it back and said, "This essay is exactly the same as your brother wrote last year." The boy said, "It's the same dog."

Special thanks are due to my wife Tina, who developed a wonderful family and a prize winning garden while I was stuck in the study or away on-site.

Contents

Part I General Introduction

1	Introduction to Asset Management	3
1.1	Purpose of This Book	3
1.2	Evolution of Asset Management	4
1.2.1	Why Do We Need Asset Management?	4
1.3	ISO 55000 Series Asset Management Standards	5
1.4	What is an Asset?	6
1.4.1	Who Needs Asset Management?	7
1.5	Asset Management Role.	7
1.6	An Accountant's View of Assets	8
1.6.1	Fixed Asset	8
1.6.2	Current Asset	9
1.6.3	Expense	9
1.6.4	Liabilities	9
1.6.5	Equity	10
1.7	What is Asset Management?	10
1.7.1	ISO 55000 Definition	10
1.7.2	Extended Definition of Asset Management	10
1.8	Aim of Asset Management.	11
1.8.1	Asset Management System	11
1.9	The Asset Life Cycle	11
1.9.1	Asset Decision Support	13
1.9.2	Regulation	13
1.10	Asset Management Basic Questions	14
1.11	Dangers of Poor Asset Management	14
1.12	Benefits of Good Asset Management	17
1.13	The Asset Death Spiral.	17
1.13.1	Texas City Oil Refinery	18
1.14	Exercises.	18
1.14.1	Self-Assessment Quiz 1.1.	18

- 1.14.2 Self-Assessment Quiz 1.2 19
- 1.14.3 Gas Processing Plant Exercise 19
- 1.15 Solutions to Exercises 20
 - 1.15.1 Self-Assessment Quiz 1.1 20
 - 1.15.2 Self-Assessment Quiz 1.2 20
 - 1.15.3 Gas Processing Plant Exercise 22
- 1.16 A Top Level Decision 22

- 2 Structure and Activities 25**
 - 2.1 Business Strategy and Asset Management 25
 - 2.2 Asset Management in the Organization 27
 - 2.3 Chief Asset Manager Role 27
 - 2.4 Asset Management in the Organization (2) 28
 - 2.5 Asset Management Groups 29
 - 2.5.1 Asset Management Groups Example 30
 - 2.6 Integrated Project Teams 31
 - 2.7 Asset Knowledge 31
 - 2.8 Asset Management Activities 32
 - 2.8.1 Deployed Assets and Asset Fleets 33
 - 2.8.2 Capital Items 35
 - 2.8.3 In-service Support 35
 - 2.9 Asset Management Policy 36
 - 2.10 Asset Management Plans 36
 - 2.11 Strategic Asset Management Plan (SAMP) 38
 - 2.12 Policy, Strategy, or Plan? 38
 - 2.13 Exercises 40
 - 2.13.1 Self-Assessment Quiz 2.1 40
 - 2.13.2 Self-Assessment Quiz 2.2 40
 - 2.13.3 Holiday Resort Exercise 40
 - 2.14 Solutions to Exercises 41
 - 2.14.1 Self-Assessment Quiz 2.1 Solution 41
 - 2.14.2 Self-Assessment Quiz 2.2 Solution 41
 - 2.14.3 Holiday Resort Exercise Solution 42

- 3 Asset Management Personnel 43**
 - 3.1 Asset Management—A Matrix Activity 43
 - 3.1.1 Understanding Needs and Expectations
of Stakeholders 44
 - 3.1.2 Understanding the Organization and Its Context 45
 - 3.2 Competence 45
 - 3.3 Required Areas of Competence 46
 - 3.3.1 Filling the Gaps 46
 - 3.4 Key Activities Where Competence Is Needed 47
 - 3.5 Roles, Responsibilities and Authorities 48

- 3.6 Engineering and Maintenance Roles 50
 - 3.6.1 Engineering Leaders 50
 - 3.6.2 Technical Authorities 50
 - 3.6.3 Maintenance Manager 50
 - 3.6.4 Maintenance Superintendent 51
 - 3.6.5 Maintenance Team Leader 51
 - 3.6.6 Maintenance Planner 51
 - 3.6.7 Maintenance Scheduler 51
 - 3.6.8 Document Controller 52
- 3.7 Personnel Development System 52
- 3.8 Competency Assessment 52
- 3.9 Leadership 53
 - 3.9.1 Communication and Response 54
- 3.10 Exercises 55
 - 3.10.1 Self-Assessment Quiz 3.1 55
 - 3.10.2 Pacific Earth Moving Part 1 55
 - 3.10.3 Self-Assessment Quiz 3.1 Solution 56
 - 3.10.4 Pacific Earth Moving Part 1 56
- 3.11 Asset Management—Who Needs It? 56

Part II Acquisition and Development of Assets

- 4 From Concept to Project Approval 61**
 - 4.1 Project Initiation 61
 - 4.2 Types of Acquisition or Development 62
 - 4.3 Business Development Planning 63
 - 4.3.1 Major Projects 63
 - 4.3.2 Minor Projects 64
 - 4.3.3 Developmental Flexibility 64
 - 4.3.4 Delegation of Financial Authority 64
 - 4.4 Capability 65
 - 4.5 Capability Requirements Planning 66
 - 4.5.1 Development Planning Teams 67
 - 4.5.2 Demand Analysis and Forecasting 68
 - 4.5.3 Demand Management 69
 - 4.5.4 Needs Analysis 69
 - 4.5.5 Un-augmented Capability Analysis 70
 - 4.5.6 Capability Gap 71
 - 4.5.7 Capability Requirements Statement 72
 - 4.6 Value Engineering 72
 - 4.6.1 Value for Money 73
 - 4.7 Creating the Development Plan 73
 - 4.8 Prefeasibility Analysis 73
 - 4.9 Feasibility Analysis 74

- 4.10 Development Plan 74
- 4.11 Development Plan Detailed Topics 75
- 4.12 Considerations in Development Planning 76
 - 4.12.1 Stakeholders 76
 - 4.12.2 Stakeholder Example 77
 - 4.12.3 Existing Processes and the Status Quo 78
 - 4.12.4 Lead Time 78
 - 4.12.5 In-Service Date 78
 - 4.12.6 Date of Decision 79
 - 4.12.7 Operational Concept Document 79
 - 4.12.8 Function and Performance Specifications 80
 - 4.12.9 Level of Service 80
 - 4.12.10 Scope of Work 80
 - 4.12.11 Financial Analysis 81
 - 4.12.12 Acquisition Strategy 81
- 4.13 Project Maturity 82
- 4.14 Implementation Portfolio 82
- 4.15 Exercises 83
 - 4.15.1 Self-Assessment Quiz 4.1 83
 - 4.15.2 Self-Assessment Quiz 4.2 84
 - 4.15.3 Capacity Planning—Generators 84
 - 4.15.4 Bottling Plant Exercise 85
 - 4.15.5 Own Project Exercise 85
- 4.16 Exercise Solutions 85
 - 4.16.1 Self-Assessment Quiz 4.1 Solutions 85
 - 4.16.2 Self-Assessment Quiz 4.2 Solutions 87
- 4.17 Capacity Planning Exercise Generators—Solution 89
- 4.18 Bottling Plant Exercise Solution 90
- 4.19 A Business Imperative 90

- 5 Financial Methods 93**
 - 5.1 Introduction 93
 - 5.2 Discounted Cash Flow 94
 - 5.2.1 Interest Rate 94
 - 5.2.2 Present Value (PV) 95
 - 5.2.3 Discount Factor 95
 - 5.2.4 Net Present Value (NPV) 96
 - 5.2.5 Cash Flow Diagram 96
 - 5.2.6 Excel Function NPV 97
 - 5.2.7 Equivalent Annual Cost (EAC) 98
 - 5.2.8 Relationship Between EAC and NPV 100
 - 5.3 Other Financial Terms 100
 - 5.3.1 Annuity Factor 100
 - 5.3.2 Capital Recovery Factor 101
 - 5.3.3 Equivalent Unit Cost (EUC) 101

- 5.4 Asset Investment Criteria 101
 - 5.4.1 Net Present Value 102
 - 5.4.2 Payback Period. 102
 - 5.4.3 Internal Rate of Return (IRR). 103
 - 5.4.4 Minimum Acceptable Rate of Return (MARR). 104
 - 5.4.5 Profitability Index. 104
 - 5.4.6 Return on Investment (ROI). 104
 - 5.4.7 Project Financial Measures—Summary. 105
- 5.5 Exercises. 105
 - 5.5.1 Discounted Cash Flow Revision Question 105
 - 5.5.2 Materials Handling System—Net Present Value Exercise 106
 - 5.5.3 Materials Handling System—Payback Period Exercise. 106
 - 5.5.4 Communications System Exercise 106
- 5.6 Financial Analysis of a Turbo-Generator Project—Exercise 107
 - 5.6.1 Materials Handling System—Net Present Value Solution 108
 - 5.6.2 Materials Handling System Payback Period—Solution 109
 - 5.6.3 Communications System Solution 109
 - 5.6.4 Financial Analysis of Turbo-Generator Exercise Solution 111
- 6 Developing a Business Case 113**
 - 6.1 Business Case Introduction 113
 - 6.2 Development Plan 114
 - 6.3 Business Case Outline 115
 - 6.4 Smaller Project Business Case Outline 117
 - 6.5 Impact of Downtime. 117
 - 6.5.1 Physical or Service Losses 118
 - 6.5.2 Cost of Failure 119
 - 6.5.3 Indicate Savings and Returns on Investment 119
 - 6.6 The Final Decision to Proceed 120
 - 6.7 Approved Development Plan 120
 - 6.8 Wine Selection Example 120
 - 6.9 Exercises. 122
 - 6.9.1 Organizational Structure and Procedures. 122
 - 6.9.2 Own Project 122
 - 6.9.3 Pacific Earth Moving Part 2 122
 - 6.10 Experience Required 123
 - 6.11 Exercise Solution 124
 - 6.11.1 Pacific Earth Moving Part 2 Solution. 124

- 7 Implementing Development Plans 125**
 - 7.1 Asset Development Portfolios 125
 - 7.1.1 Requirements Portfolio 126
 - 7.1.2 Planning Portfolio 126
 - 7.1.3 Implementation Portfolio 127
 - 7.1.4 In-Service Assets 127
 - 7.1.5 Disposal Portfolio. 127
 - 7.2 Project Team and Activities 127
 - 7.2.1 Team Functions 127
 - 7.2.2 Project Management. 128
 - 7.2.3 Activities 128
 - 7.3 Project Milestones 129
 - 7.4 Reliability Centered Procurement 129
 - 7.4.1 Equipment Commonality 130
 - 7.4.2 Performance Standards. 130
 - 7.4.3 Test and Evaluation Criteria 131
 - 7.4.4 Preferred Suppliers. 131
 - 7.5 Evaluation of Suppliers 131
 - 7.6 Equipment Selection and Trials and Acceptance 132
 - 7.7 Through Life Support. 133
 - 7.8 Financial and Contract Process 133
 - 7.9 Project Maturity Status. 133
 - 7.10 Assigning Responsibilities 133
 - 7.11 Project Management Reports 135
 - 7.11.1 Topics 135
 - 7.11.2 Financial Overview Report. 135
 - 7.12 Project Progress Monitoring. 135
 - 7.12.1 Delays and Overruns 136
 - 7.12.2 Scope Creep 137
 - 7.12.3 Project Progress Report Examples 137
 - 7.13 Project Portfolio Management 137
 - 7.14 Commissioning and Introduction into Service. 139
 - 7.14.1 Operational Readiness 140
 - 7.14.2 Training 141
 - 7.14.3 Introduction into Service 141
 - 7.15 Change Management 142
 - 7.15.1 Change Analysis. 142
 - 7.15.2 Change Management Plan 143
 - 7.15.3 Approval of Changes 143
 - 7.16 Exercises. 144
 - 7.16.1 Self-Assessment Quiz 6.1. 144
 - 7.16.2 Pacific Earth Moving Part 3 144
 - 7.17 Exercise Solutions 144
 - 7.17.1 Self-Assessment Quiz 6.1. 144
 - 7.18 Pacific Earth Moving Part 3 Solution. 146
 - 7.19 An Acquisition Decision 146

- 8 Life Cycle Costing** 149
 - 8.1 Life Cycle Costing 149
 - 8.1.1 Why Do We Need Life Cycle Costing? 149
 - 8.2 Acquisition Decisions 150
 - 8.3 Life Cycle Asset Management Plan 151
 - 8.3.1 Why Do We Need a Life Cycle Asset Management Plan? 151
 - 8.3.2 Sources of Information. 151
 - 8.4 Replacement Decisions 152
 - 8.5 Life Cycle Planning and Costing Elements 152
 - 8.5.1 Acquisition 152
 - 8.5.2 Operations 153
 - 8.5.3 Maintenance 153
 - 8.5.4 Support Services. 153
 - 8.5.5 Disposal 154
 - 8.5.6 Buildings—Design and Construction. 154
 - 8.5.7 Buildings—Operation, Maintenance, and Disposal 154
 - 8.6 Life Cycle Costing Example 155
 - 8.7 Input to Plans and Budgets. 157
 - 8.7.1 Acquisition 157
 - 8.7.2 Support Facilities and Logistics Planning 157
 - 8.7.3 In-Service Asset Management Planning and Budgeting 157
 - 8.8 Exercises. 158
 - 8.8.1 Self Assessment Quiz 158
 - 8.8.2 Solution to Self Assessment Quiz 158

Part III Managing In-service Assets

- 9 Know Your Assets** 161
 - 9.1 Awareness of Key Assets 161
 - 9.1.1 Examples 162
 - 9.2 Acquisition of Asset Knowledge 164
 - 9.3 Block Diagrams 164
 - 9.3.1 Information Required Per Block 164
 - 9.3.2 Drawings 165
 - 9.4 Criticality 165
 - 9.4.1 Example—Chemical Plant 165
 - 9.4.2 Example—Mining Site. 166
 - 9.5 Expert Teams 167
 - 9.6 Bottlenecks 167
 - 9.7 Backlogs. 168
 - 9.8 Asset Condition 168

- 9.9 Plant Criticality Exercise 169
- 9.10 Plant Criticality Exercise Solution 170
- 9.11 Look Back in Embarrassment 170

- 10 Asset Continuity Planning 173**
 - 10.1 Asset Continuity. 173
 - 10.1.1 Factors in Continuity Planning. 174
 - 10.2 Asset Data. 174
 - 10.3 Planning Terminology 174
 - 10.4 Planning Schedules 176
 - 10.5 Planning Schedules Example 176
 - 10.5.1 Expiry Schedule 177
 - 10.5.2 Acquisition and Cost Schedule 177
 - 10.5.3 Application of the Acquisition and Cost Schedule. 177
 - 10.6 Planning Example with Varying Needs 178
 - 10.6.1 Preplan Gap Analysis 178
 - 10.6.2 Creating the Purchase Plan. 180
 - 10.7 Capability Continuity Planning 182
 - 10.8 Columnar Format 182
 - 10.9 Exercises. 183
 - 10.9.1 Continuity Planning 183
 - 10.9.2 Vehicle Fleet Capacity Exercise. 183
 - 10.10 Exercise Solutions 184
 - 10.10.1 Continuity Planning Solution. 184
 - 10.10.2 Vehicle Fleet Capacity Exercise. 184

- 11 Management of In-Service Assets 187**
 - 11.1 In-Service Assets 187
 - 11.2 In-Service Support Aims 187
 - 11.3 In-Service Support Activities 188
 - 11.4 Organization for In-Service Support 190
 - 11.5 Engineering and Technical Services. 191
 - 11.6 Asset Management Plans 191
 - 11.6.1 ISO 55000 Definition and Requirements 191
 - 11.6.2 Life Cycle Asset Management Plan 192
 - 11.6.3 Planning-Period Asset Management Plan 192
 - 11.6.4 Planning Overview 192
 - 11.6.5 Asset Management Plan Inputs 194
 - 11.6.6 Planning Considerations. 194
 - 11.6.7 Consolidated Asset Management Plan. 195
 - 11.6.8 Plan Summary 195
 - 11.7 Time Period (e.g., 5 Year) Asset Management Plan. 196
 - 11.7.1 Introduction 196
 - 11.7.2 Relationship to the SAMP 197
 - 11.7.3 Role of the 5 Year Asset Management Plan 197

- 11.7.4 Development of the 5 Year Plan 198
- 11.7.5 Outline Contents of a 5 Year
Asset Management Plan 198
- 11.8 Configuration Management 200
 - 11.8.1 Configuration Management Example. 200
 - 11.8.2 Configuration Description 200
 - 11.8.3 Configuration Management Process. 201
 - 11.8.4 Configuration Change Control 201
- 11.9 Exercises. 201
 - 11.9.1 Self-Assessment Quiz 9.1. 201
 - 11.9.2 Configuration Management Exercise 202
- 11.10 Exercise Solutions 202
 - 11.10.1 Self-Assessment Quiz 9.1 Solution 202
 - 11.10.2 Configuration Management Solutions 203
- 11.11 Roll Over 204

- 12 Capital Planning and Budget 207**
 - 12.1 Capital Planning Considerations 207
 - 12.1.1 Cyclic Aspect 208
 - 12.2 What is a Budget?. 208
 - 12.3 Types of Budget 208
 - 12.4 Budget Structure. 209
 - 12.5 Devolution of Authority 209
 - 12.6 Organizational Planning Process 210
 - 12.7 Asset Planning Process. 210
 - 12.7.1 Planning Periods. 211
 - 12.7.2 Source and Application of Funds 211
 - 12.8 Capital Requirement Plans for Asset Types 212
 - 12.9 Capital Budgeting Cycle 213
 - 12.10 Capital Rationing 213
 - 12.10.1 Capital Rationing Example—Postal Vans 214
 - 12.10.2 Replacement Prioritization. 215
 - 12.10.3 Condition/Criticality Plot 215
 - 12.10.4 Financial Return 216
 - 12.10.5 Risk. 216
 - 12.11 The Capital Budget. 217
 - 12.12 Managing the Capital Project Portfolio 217
 - 12.12.1 Capital Budget for Current Year. 218
 - 12.13 Contingency Allowances 219
 - 12.14 Exercises. 219
 - 12.14.1 Self-Assessment Exercise 12.1. 219
 - 12.14.2 Long River Ferry Company Exercise. 219
 - 12.15 Are Your Assets Liabilities? 220
 - 12.16 Exercise Solutions 221
 - 12.16.1 Self-Assessment Exercise 12.1 Solution 221
 - 12.16.2 Long River Ferry Company Exercise Solution 222

13 Asset Management Information Systems 223

13.1 Information System Role and Applications 223

13.2 Base Data and the Need for Coding 225

 13.2.1 Fixed Plant and Functional Locations 225

 13.2.2 Location Code Structure. 227

 13.2.3 Mobile Plant Coding 228

 13.2.4 Activity and Trade Codes 228

13.3 Resourcing and Managing the System 229

 13.3.1 Data Administration 229

 13.3.2 Information Technology Support 229

 13.3.3 Users 230

13.4 Reports and Their Uses 230

13.5 Document Control 231

13.6 Implementing Changes 231

13.7 Exercises 232

 13.7.1 Asset Data Setup Exercise 232

 13.7.2 Pacific Earth Moving Part 4 AM Info. System 233

13.8 Exercise Solutions 234

 13.8.1 Asset Data Setup Exercise 234

 13.8.2 Pacific Earth Moving Part 4 AM Info. System Solution 234

Part IV General Management Considerations

14 Cost–Benefit Analysis 239

14.1 Cost–Benefit Analysis 239

 14.1.1 Nonfinancial Benefits 239

14.2 Cost–Benefit Analysis Outline 240

 14.2.1 A Basic Example 240

14.3 Needs and Wants 241

14.4 User Pays Principle 242

14.5 Activity-Based Cost–Benefit Analysis 243

14.6 Lost Opportunity Cost 243

14.7 Measures of Benefit 244

14.8 Cost–Benefit Analysis Steps 244

 14.8.1 Activity-Based Cost–Benefit Summary Sheet 244

14.9 Regional Health Clinics Exercise 246

14.10 Regional Health Clinics Exercise Solution 246

14.11 Cost–Benefit Spider Diagram 248

15 Risk Analysis and Risk Management 249

15.1 Aim 250

15.2 References 250

15.3 Risk Analysis 251

- 15.4 Definitions 251
- 15.5 Management of Risk 251
 - 15.5.1 Risk Management Documents 252
- 15.6 Take 5 253
- 15.7 Legislative Approach 253
- 15.8 Types of Risk 255
 - 15.8.1 Sovereign Risk 255
 - 15.8.2 Solution Risk 255
 - 15.8.3 Technical Development Risk 255
 - 15.8.4 Performance Risk 256
 - 15.8.5 Commercial or Financial Risk 256
 - 15.8.6 Administrative Risk 256
 - 15.8.7 Safety and Environmental 256
 - 15.8.8 Supplier Risk 256
 - 15.8.9 Resources 256
- 15.9 Hazard Analysis 257
- 15.10 Consequences 257
- 15.11 Risk Analysis and Risk Rating 257
 - 15.11.1 Risk Matrix 258
 - 15.11.2 Consequence Ratings 259
- 15.12 Risk Register 259
- 15.13 Mitigating Risk 259
- 15.14 Contingency Planning 260
 - 15.14.1 Contingency Allowance 260
 - 15.14.2 Contingency Plan 261
 - 15.14.3 Retirement of Risk 261
- 15.15 Quantitative Risk Analysis 261
- 15.16 Other Methods 262
- 15.17 Project Risk Examples 263
- 15.18 Water Supply System Example 263
 - 15.18.1 Hazard Analysis 265
 - 15.18.2 Risk Treatment 265
 - 15.18.3 Monitoring and Audit 269
- 15.19 Exercises 269
 - 15.19.1 Self-Assessment Exercise 15.1 269
 - 15.19.2 Self-Assessment Exercise 15.1 Solution 270
- 16 Outsourcing 271**
 - 16.1 Introduction 271
 - 16.2 What to Outsource 272
 - 16.2.1 Noncore Activities 272
 - 16.2.2 Minor Player 272
 - 16.2.3 Peak Load Resources 272
 - 16.3 The Owner/Operator Model 273

- 16.4 What NOT to Outsource. 273
 - 16.4.1 Core Activities 273
 - 16.4.2 High Customer Impact 273
 - 16.4.3 Problem Areas 273
 - 16.4.4 Examples 273
- 16.5 Benefits of Outsourcing 274
 - 16.5.1 Concentration on Core Business 274
 - 16.5.2 Redress Workforce Imbalances 274
 - 16.5.3 Reduce Fixed Costs 274
 - 16.5.4 Review Maintenance Practices and Resources. 275
- 16.6 Costs of Outsourcing 275
 - 16.6.1 Formalization 275
 - 16.6.2 Intangible Effects 275
 - 16.6.3 Other Potential Negatives. 276
- 16.7 Types of Contract 277
- 16.8 Contract Features 278
- 16.9 Limiting Risks in Outsourcing 278
 - 16.9.1 Audit. 279
- 16.10 Outsourcing Result. 279
 - 16.10.1 Example 280
- 16.11 Contractor Viewpoint 280
- 16.12 Build Own Operate Transfer (BOOT) 280
- 16.13 Public Private Partnerships (PPP). 281
- 16.14 Exercises. 282
 - 16.14.1 Self-Assessment Exercise. 282
 - 16.14.2 Self-Assessment Exercise Solution 282

Part V Technical Areas

- 17 Logistic Support 285**
 - 17.1 Introduction 285
 - 17.2 Logistic Support Analysis (LSA). 286
 - 17.2.1 Logistic Support Basic Data. 287
 - 17.2.2 Logistic Support Detailed Factors 287
 - 17.3 Level of Repair Analysis (LORA) 288
 - 17.3.1 Levels of Repair 289
 - 17.4 Integrated Logistic Support (ILS) 291
 - 17.5 Logistic Support Plan 292
 - 17.6 Through Life Support. 293
 - 17.7 Configuration Management Plan 293
 - 17.8 Through Life Support Contract 294
 - 17.9 Logistic Support Example 294
 - 17.10 Supplier or Contractor Viewpoint. 295
 - 17.11 Cunning at the Castle 297

- 17.12 Exercises 298
 - 17.12.1 Self-Assessment Questions 298
 - 17.12.2 Logistic Support Analysis—Tooth Brush. 298
 - 17.12.3 Racing Cycle Team. 299
 - 17.12.4 Level of Repair Analysis Exercise 299
- 17.13 Exercise Solutions 299
 - 17.13.1 Self-Assessment Questions Solutions 299
 - 17.13.2 Logistic Support Analysis—Tooth Brush Solution . . . 301
 - 17.13.3 Cycle Team Logistic Support Exercise Solution 301
 - 17.13.4 Level of Repair Analysis Exercise 301
- 18 Asset Basic Care 303**
 - 18.1 Introduction 303
 - 18.2 Total Productive Maintenance or Asset Basic Care 304
 - 18.2.1 Workplace Tidiness and Organization 304
 - 18.2.2 Maintain Standards. 305
 - 18.2.3 Training 306
 - 18.2.4 Machine Knowledge. 306
 - 18.3 Basic Maintenance 306
 - 18.3.1 Assign Housekeeping and Basic Maintenance Tasks . . . 307
 - 18.3.2 Routine Maintenance by Technicians. 308
 - 18.3.3 Accredit Workers 308
 - 18.4 Performance Recording 308
 - 18.5 Continuous Improvement. 309
 - 18.5.1 Deming Wheel 309
 - 18.5.2 Fish Bone Diagram (Ishikawa). 310
 - 18.6 Improvement Coordinator 311
 - 18.7 Asset Basic Care/TPM—Management Support. 312
 - 18.7.1 Asset Basic Care/TPM Summary. 312
 - 18.7.2 Asset Basic Care/TPM Benefits. 312
 - 18.8 A Shock from Japan 313
 - 18.9 Self-Assessment Exercise. 314
 - 18.10 Self-Assessment Exercise Solutions 314
- 19 Maintenance Organization and Budget 317**
 - 19.1 Maintenance Aim 317
 - 19.2 Maintenance Organization 317
 - 19.2.1 Maintenance Layout. 318
 - 19.3 Types of Maintenance Activity. 319
 - 19.3.1 Additional Related Tasks 320
 - 19.4 Maintenance Work Management 320
 - 19.4.1 Inspection and Scoping 321
 - 19.4.2 Planning and Costing 322
 - 19.4.3 Scheduling 322
 - 19.4.4 Maintenance Control 322
 - 19.4.5 Personnel Roles 322

- 19.4.6 Planning and Control Process 323
- 19.4.7 Planners Checklist 325
- 19.4.8 Job Priorities Scheme 325
- 19.4.9 Weekly Scheduling Process 325
- 19.5 Maintenance Budgeting 326
 - 19.5.1 The Business Plan 326
 - 19.5.2 Zero-Based Budgeting 326
 - 19.5.3 Creating the Budget 327
 - 19.5.4 Using the History 328
 - 19.5.5 Walking Around 328
 - 19.5.6 Backlog. 328
 - 19.5.7 Sources of Maintenance Work 329
 - 19.5.8 Changes in Demand 329
 - 19.5.9 Direct Labor Estimates—Routine 330
 - 19.5.10 Nonroutine and Breakdown Labor Estimate 330
 - 19.5.11 Specific Items 331
 - 19.5.12 In-direct Labor 332
 - 19.5.13 Overheads. 332
 - 19.5.14 The Maintenance Iceberg 332
 - 19.5.15 Arrive at the Resource Requirement 333
 - 19.5.16 Correct the Imbalances. 334
- 19.6 Costing 334
- 19.7 Survey and Quote 335
- 19.8 Budget Cost Control 335
- 19.9 Budget Reports 336
- 19.10 Activity-Based Costing 337
 - 19.10.1 Examples 337
- 19.11 Exercises 338
 - 19.11.1 Self-Assessment Exercise 338
 - 19.11.2 Maintenance Budgeting Exercise 338
 - 19.11.3 Pacific Earth Moving Part 5: Maintenance 338
- 19.12 Exercise Solutions 339
 - 19.12.1 Self-Assessment Exercise Solution 339
 - 19.12.2 Maintenance Budgeting Exercise Solution 340
 - 19.12.3 Pacific Earth Moving Part 5: Maintenance Solution 341
- 20 Stock Control 343**
 - 20.1 Introduction 343
 - 20.2 Aims of Inventory Management 344
 - 20.3 Initial Spares Purchase 344
 - 20.4 Cataloguing 344
 - 20.5 Inventory Management Basics 345
 - 20.5.1 Stock Keeping Units or SKUs 346
 - 20.5.2 Spare Parts Catalog 347
 - 20.6 Procedure When an Item Is Needed 347

- 20.7 Stock Status and Control Terminology. 347
 - 20.7.1 Multiple Locations and Status Settings 348
- 20.8 Dependent Demand 349
 - 20.8.1 Kanban System. 349
 - 20.8.2 Materials Requirement Planning (MRP) Report 349
- 20.9 Independent Demand Items 350
 - 20.9.1 Fast Moving Items 350
 - 20.9.2 Reorder Level. 351
 - 20.9.3 Lead Time. 351
 - 20.9.4 Reorder Quantity 352
 - 20.9.5 MIN and MAX. 352
- 20.10 Target Level 352
- 20.11 Forecasting 352
- 20.12 Reorder Risks 353
- 20.13 Inventory Faults 354
- 20.14 Safety Stock 354
- 20.15 Item Criticality 354
- 20.16 Summary of Reorder Rules Fast Moving. 355
 - 20.16.1 Stock Control Example 355
- 20.17 Current Action 355
- 20.18 Complications. 356
 - 20.18.1 Consignment. 356
 - 20.18.2 Cannibalization. 357
 - 20.18.3 Returned Stores 357
 - 20.18.4 Storekeeper Personnel 357
 - 20.18.5 Overstocking 357
- 20.19 Repair Pools and Rotables 357
 - 20.19.1 Repair Parts 358
- 20.20 Slow Moving Items 358
 - 20.20.1 Example 360
- 20.21 Insurance Spares. 360
- 20.22 Summary of Policy Types. 360
- 20.23 Performance Indicators. 360
 - 20.23.1 Service Level 360
 - 20.23.2 Days Supply 361
 - 20.23.3 Dead Stock 361
 - 20.23.4 Stock Turns Per Year 362
 - 20.23.5 Value Turns. 362
 - 20.23.6 ABC Analysis. 362
 - 20.23.7 Inventory Improvement Actions. 363
- 20.24 Accounting for Inventory 363
 - 20.24.1 Inventory in the Balance Sheet. 364
 - 20.24.2 Inventory in the Profit and Loss Account. 364
 - 20.24.3 Overstocking and Write Downs 364
- 20.25 So How Did We Win?. 365

- 20.26 But Problems Remain. 366
- 20.27 Exercises. 368
 - 20.27.1 Self-Assessment Exercise 20.1. 368
 - 20.27.2 Self-Assessment Exercise 20.2. 368
 - 20.27.3 Reorder Level Exercise 369
 - 20.27.4 Reorder Quantity Exercise 369
 - 20.27.5 Actual Order Decisions Exercises 369
 - 20.27.6 Self-Assessment Exercise 20.1 Solution 371
 - 20.27.7 Self-Assessment Exercise 20.2 Solution 372

- 21 Reliability, Availability, and Maintainability 373**
 - 21.1 Introduction 373
 - 21.2 Reliability. 373
 - 21.3 Specification and Testing 374
 - 21.3.1 Mean Time Between Failures. 374
 - 21.3.2 Failure Rate 374
 - 21.3.3 Failure. 375
 - 21.4 Design for Reliability 375
 - 21.5 Managing the Reliability of In-service Assets 375
 - 21.5.1 Operator Records and Incident Reports 375
 - 21.5.2 Toolbox Meetings. 376
 - 21.5.3 Management Reaction 377
 - 21.6 Failure Patterns and Causes 377
 - 21.7 Failure Pattern Discussion 378
 - 21.7.1 Useful Life 378
 - 21.7.2 Burn-in Failures 379
 - 21.7.3 Random Failure Examples 379
 - 21.7.4 Wearout 380
 - 21.7.5 Failure Mode Relative Importance. 380
 - 21.7.6 Failure Interdependency. 381
 - 21.7.7 Bad Actor 381
 - 21.8 Failure Reporting and Corrective Action System (FRACAS). 382
 - 21.9 Pareto Analysis. 383
 - 21.10 Failure Mode and Effects Analysis. 383
 - 21.10.1 Common Failure Modes and Mechanisms. 384
 - 21.11 Root Cause Analysis (RCA). 384
 - 21.11.1 Five Whys. 386
 - 21.11.2 Action and Condition Causes. 387
 - 21.11.3 Example—Pump Failure 387
 - 21.11.4 Brainstorming a Solution 388
 - 21.11.5 Example—Pump Failure Continued 388
 - 21.11.6 Actions to Remedy. 389

- 21.12 Condition Monitoring. 389
 - 21.12.1 Delay Time or P-F Interval. 390
 - 21.12.2 Condition Monitoring Applicability. 390
 - 21.12.3 Limitations 391
 - 21.12.4 Condition Monitoring Effectiveness 391
 - 21.12.5 Applications of Condition Monitoring. 392
- 21.13 Reliability Centered Maintenance 392
 - 21.13.1 Information Sources 393
 - 21.13.2 Guidelines. 393
 - 21.13.3 Function and Functional Failure. 394
 - 21.13.4 Functional Failure. 395
 - 21.13.5 Failure Mode 395
 - 21.13.6 Effects. 396
 - 21.13.7 Hidden Failures 396
 - 21.13.8 Tasks. 396
 - 21.13.9 Reliability Centered Maintenance Conclusion. 397
- 21.14 Maintenance Policy Review 397
 - 21.14.1 Example 398
- 21.15 Availability 398
 - 21.15.1 System Availability. 399
 - 21.15.2 Cost of Downtime 400
 - 21.15.3 Availability When Needed 400
- 21.16 Availability Related to Total Time 401
- 21.17 Maintenance Effectiveness. 401
- 21.18 Maintenance Load 403
- 21.19 Maintenance Regime 403
- 21.20 Maintainability 403
 - 21.20.1 Design for Maintainability 403
- 21.21 Maintainability Measure. 405
- 21.22 Desert Song 406
- 21.23 Exercises. 406
 - 21.23.1 Self-Assessment Exercise. 406
 - 21.23.2 Pacific Earth Moving Pt 6: Reliability and Availability. 407
 - 21.23.3 Cost of Downtime 407
 - 21.23.4 Availability Related to Total Time 407
 - 21.23.5 Hydraulic Faults 408
- 21.24 Exercise Solutions 408
 - 21.24.1 Self-Assessment Exercise Solution 408
 - 21.24.2 Pacific Earth Moving Part 6: Solution 410
 - 21.24.3 Cost of Downtime 410
 - 21.24.4 Availability Related to Total Time 410
 - 21.24.5 Hydraulic Faults Solution. 411

22 Safety 413

22.1 Safety Requirements and Competence. 413

22.1.1 Safety Practices 414

22.1.2 Training and Information 415

22.1.3 Permits 415

22.1.4 Tags 416

22.1.5 Danger Indications 416

22.2 Safety Critical Equipment (SCE) and Systems (SCS) 416

22.2.1 Safety Critical Examples 417

22.2.2 Risk-Based Inspection 417

22.2.3 Example—Distillation System. 418

22.2.4 Asset Integrity Management Plan (AIMP). 419

22.2.5 Maintenance Specific to Safety Critical Equipment . . . 419

22.2.6 Internal Corrosion Management. 420

22.2.7 Protective Devices 420

22.2.8 Record Keeping 421

22.3 Layer of Protection Analysis (LOPA) 421

22.4 Safety Integrity Level (SIL) 422

22.4.1 Design for Safe Operation 422

22.4.2 Facility Siting and Layout 423

22.4.3 Fitness for Service Assessment 423

22.5 Repairs Requiring Engineering 423

22.6 Terminology Summary. 424

22.7 Exercises. 424

22.7.1 Self-Assessment Quiz. 424

22.7.2 Self-Assessment Quiz Solutions 425

Part VI Financial Analysis

23 Profit, Depreciation, and Tax 429

23.1 Introduction 429

23.2 Capital Transactions 429

23.3 Depreciation 430

23.3.1 Acquisition Cost. 430

23.3.2 Book Value (or Written Down Value, WDV) 430

23.3.3 Effective Life 430

23.3.4 Straight Line Depreciation 431

23.3.5 Residual Value 431

23.3.6 Declining Balance Depreciation. 432

23.4 Profit and Loss Account 433

23.5 Profit Calculations 433

23.6 Cash Flow Statement 434

23.6.1 Depreciation Tax Credit 435

23.6.2 Maintenance Tax Credits 436

23.6.3	Tax Credit Summary	436
23.6.4	Tax on Resale	436
23.7	Pre-tax and After-Tax Cash Flow Diagrams.	437
23.7.1	Pre-tax Cash Flow Diagram	437
23.7.2	After-Tax Cash Flow Diagram	438
23.8	Conclusion	438
23.9	Exercises.	439
23.9.1	Self-Assessment Exercise 23	439
23.9.2	Profit Calculation Exercise.	439
23.10	Self-Assessment Exercise 23 Solution	439
23.10.1	Profit Calculation Exercise—Solution	440
24	Asset Decision Examples.	441
24.1	Repair/Replace Decision for Ore Loading Vehicles.	441
24.1.1	Situation	441
24.1.2	Required Decision	442
24.1.3	Factors Involved in the Replace or Overhaul Decision	442
24.2	Replace Option.	443
24.2.1	New Ore Loader Costs	443
24.3	New Loader Life Cycle NPV and EAC	444
24.4	Overhaul Option.	444
24.4.1	Old Ore Loader Costs.	444
24.5	Cost Summary	445
24.6	Ore Loader Cost Analysis with Tax	446
24.6.1	“Replace” Option with Tax	446
24.6.2	“Overhaul” Option with Tax.	447
24.6.3	Loader Initial Policy Decision	447
24.7	Availability and Reliability.	448
24.7.1	Replace/Overhaul Ore Loader Conclusion.	449
24.8	Exercises.	449
24.8.1	Standby Generator Exercise	449
24.8.2	Solar or Diesel Power Exercise	449
24.9	Exercise Solutions	450
24.9.1	Standby Generator Exercise Solution.	450
24.9.2	Solar or Diesel Power Exercise Solution	452
25	Economic Life	455
25.1	Economic Life Concept	455
25.2	Economic Life Example.	455
25.2.1	Hand Calculation	456
25.2.2	Spreadsheet Calculation.	457
25.2.3	Economic Life with Discounting	458
25.2.4	Economic Life with Discounting and Tax	460

- 25.3 Exercises 460
 - 25.3.1 Self-Assessment Exercise 460
 - 25.3.2 Self-Assessment Exercise Solution 461

- 26 Equipment Replacement Decisions 463**
 - 26.1 Replacement Planning 463
 - 26.2 Reasons for Equipment Replacement 464
 - 26.3 Technical Assessment 466
 - 26.4 Data Analysis 466
 - 26.5 Cost Analysis for Replacement 466
 - 26.5.1 Like-with-Like Replacement 466
 - 26.5.2 Equivalent Annual Cost of the Challenger 467
 - 26.5.3 Steadily Increasing Cost Case 467
 - 26.5.4 Savings 468
 - 26.5.5 Unevenly Changing Cost Case 469
 - 26.6 Spend-Limits 469
 - 26.6.1 Spend-Limit Example 470
 - 26.7 Risk with Ageing Equipment 470
 - 26.7.1 Risk-Cost 471
 - 26.8 Linear Assets 471
 - 26.8.1 Cost Structure 472
 - 26.8.2 High Consequence Assets 472
 - 26.8.3 Low Consequence, Long Life Asset Replacement 473
 - 26.9 What Length of Asset Should Be Replaced? 473
 - 26.9.1 Cost Structure of Replacement 473
 - 26.9.2 Contiguous Replacement 475
 - 26.9.3 Linear Assets Conclusion 475
 - 26.10 Component Replacement 475
 - 26.10.1 Condition-Based Replacement 476
 - 26.10.2 Failure Replacement and Run-to-Failure 476
 - 26.10.3 Age-Based or Service-Based Replacement 476
 - 26.11 Exercises 477
 - 26.11.1 Vehicle Replacement Exercise 477
 - 26.11.2 Transformer Replacement Exercise 477
 - 26.11.3 Spend-Limit Exercise 478
 - 26.12 Solutions to Exercises 479
 - 26.12.1 Vehicle Replacement Exercise Solution 479
 - 26.12.2 Transformer Replacement Exercise 479
 - 26.12.3 Spend-Limit Exercise 480

- 27 Further Financial Topics 481**
 - 27.1 Debt and Equity Financing 481
 - 27.2 Comparison and Selection of Projects 482
 - 27.2.1 Project Comparability 482
 - 27.2.2 Planning Horizon 482

27.2.3	With and Without Analysis	482
27.3	Inflation	483
27.3.1	Adjusting Historical Costs	483
27.3.2	Real Rate of Interest	484
27.3.3	Adjusting Future Costs	484
27.4	Asset Valuation	484
27.4.1	Current Replacement Cost	485
27.4.2	Deprival Value	486
27.4.3	Asset Value Index	486
27.5	Sinking Fund	487
27.6	Leasing	487
27.7	Loan Repayment	488
27.8	Fixed Costs, Variable Costs, and Break-Even Analysis	489
27.9	Regulation	490
27.9.1	Methods	490
27.9.2	Need for Adequate Returns	491
27.9.3	Stranded Assets	491
27.10	Concluding Discussion	491
27.11	Exercises	492
27.11.1	Self-Assessment Quiz	492
27.11.2	An Asset Investment Case Study	492
27.12	Exercise Solutions	493
27.12.1	Self-Assessment Quiz Solution	493
27.12.2	Asset Investment Case Study Solution	494
28	Performance, Audit, and Review	497
28.1	Key Performance Indicators	497
28.1.1	Railway System Indicators	498
28.1.2	Water Supply System Indicators	498
28.1.3	Electricity Transmission or Distribution	499
28.1.4	Trucks	499
28.2	Overall Equipment Effectiveness	500
28.3	Maintenance-Related Performance Indicators	500
28.4	Audit of the Asset Management System	501
28.5	Management Review	501

Part VII ISO 55000 Standard

29	ISO 55000 Series Standards	505
29.1	Introduction	505
29.1.1	ISO 55000 Fundamentals	506
29.1.2	ISO 55001 and ISO 55002	507
29.2	ISO 55001 Clauses and Book Cross-References	507
29.3	ISO 55001 Clauses and Figures	518

29.4	Strategic Asset Management Plan (SAMP)	519
29.5	SAMP Outline Contents	520
29.6	Functional Gap Analysis	521
29.7	Buzz-Word Generator	525
Appendix		527
Bibliography		529
Index		533

About the Author



Nicholas Anthony John Hastings has worked for over 50 years in the field of engineering asset management. His early career was in the British Army. He attended the Royal Military Academy, Sandhurst, and the University of Cambridge and served in the Royal Electrical and Mechanical Engineers. He worked initially in maintenance management and later in asset management policy, focusing on planning for the ongoing sustainment of equipment fleets and the development of repair/replace decision guidelines.

From 1977 to 1994 he was professor of operations research at Monash University in Melbourne, Australia, and from 1994 to 2001 he held the Mount Isa Mines Chair in Maintenance Engineering at Queensland University of Technology, Brisbane, Australia. His work involved asset management projects in manufacturing, mining, electricity supply, water supply, gas industry, and defense. In 2006 he was awarded the Medal of the Maintenance Engineering Society of Australia for contributions to reliability and engineering asset management. In 2009 he was an expert witness on asset management issues for the Victorian Bushfire Royal Commission into the Black Saturday bushfires, Australia's worst bushfire disaster.

He is a director of Albany Interactive Pty Ltd., a consultancy firm in engineering asset management, and is an external lecturer in Asset Management Systems at Central Queensland University. He enjoys country walks and playing table tennis.

He is a co-author of *Statistical Distributions*, published by John Wiley and Sons and author of *A Tree Too Far*, a novel based on the 2009 Black Saturday bush fire tragedy.

About the Book

Physical asset management is the management of fixed assets such as machinery, vehicles, equipment, plant, buildings, and infrastructure. This book presents a systematic approach to the management of these assets from concept to disposal. It makes particular reference to the ISO 55000 series of asset management standards.

It is designed to be suitable as:

- A textbook for a course in asset management to senior undergraduate or graduate students in asset management, engineering management, public works engineering, systems engineering, industrial engineering, maintenance engineering or operations management.
- A reference point for engineers and managers working in the asset management field.
- An introduction to ISO55000 and a reference point for the techniques required to implement this standard.

The book introduces the general principles of physical asset management, covering all stages of the asset life cycle. This starts with initial business appraisal and proceeds through identification of fixed asset needs, capability gap analysis, financial evaluation, logistic support analysis, life cycle costing, management of in-service assets, maintenance strategy, outsourcing, budgeting, cost-benefit analysis, disposal, and renewal. Industries to which this is applicable include: manufacturing; distribution; mining; electricity generation and supply; oil and gas; water; roads; railways; aviation; shipping; hospitals; retail centers; defense material; recreation and sporting facilities and local government.

The chapters in this book are designed to introduce material in a logical sequence. As a whole year educational program it is suggested that Chaps. 1–16 provide material for the first semester and Chaps. 17–29 provide material for the second semester.

Melbourne, 2014

Nicholas Anthony John Hastings

Part I
General Introduction

Chapter 1

Introduction to Asset Management

Abstract The aim of this chapter is to introduce to the main concepts of Asset Management. *Outcomes* After reading this chapter you will know about:

- The purpose of this book;
- The historical background to asset management;
- The ISO 55000 series of standards for asset management;
- Definitions of assets, liabilities, and related terms with reference to ISO 55000 and to accounting applications;
- The broad types of assets which organizations have;
- The types of industry to which asset management is particularly important;
- The aim of asset management within an organization;
- An outline of the asset management life cycle;
- The basic questions to be addressed by asset management;
- The benefits of good asset management;
- The dangers of the asset death spiral.

1.1 Purpose of This Book

This book presents a systematic approach to the management of physical assets from concept to disposal. The aim is to develop the general principles of asset management in order to make them accessible to a wide audience.

The book is intended to act as an introductory text which can form the basis for educational courses in asset management at the postgraduate or advanced undergraduate level, as well as being suited to the asset management practitioner as a convenient reference on asset management topics.



Fig. 1.1 Military assets—city of Ur 2600 B.C. From the “Standard of Ur”

1.2 Evolution of Asset Management

The development of physical assets has been a hallmark of human activity from early times. Figure 1.1 shows military wagons from the city of Ur dating from 2600 B.C. Clearly the citizens of Ur were familiar with the wheel, but this means that there must also have been artisans who were familiar with the bearing, on which the wheel depends, with lubrication on which the bearing depends, and with the lathe and other woodworking and metalworking tools needed to build the wheels and the wagons. A developed system of manufacture, maintenance, and logistic support for these assets must have existed from a very early date.

Despite these early beginnings, physical asset management has never been a well-understood activity within populations at large. The pattern of educational and professional specializations has generally by-passed the physical asset management field. Various technical areas, such as defense, aviation, and civil works, have evolved their own approaches to the topic, under such headings as logistics, systems engineering, public works engineering, infrastructure, and maintenance.

1.2.1 Why Do We Need Asset Management?

The need for asset management as a recognized discipline arises from the complex technical nature of modern systems. Let us take an example from aviation. A contrast can be drawn between, on the one hand, the Wright Brothers Flyer of 1903 (Fig. 1.2), which was the first aircraft to achieve controlled flight, and on the other hand, the modern aviation industry.

Initially, the Wright brothers designed, built, flew, repaired, and financed their own aircraft. They did not need asset management as a separate activity. But, aviation today involves flight operations, engineering, maintenance, finance, human resources, and a wide range of asset types on a huge scale. Figure 1.3 gives some indication of this. It is this vast increase in complexity, across a wide range of industries, which has led to the need for asset management as a recognized discipline.

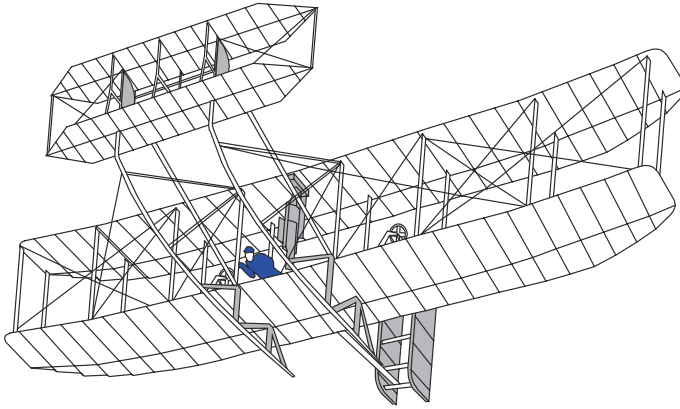

Fig. 1.2 Wright Brothers Flyer 1903

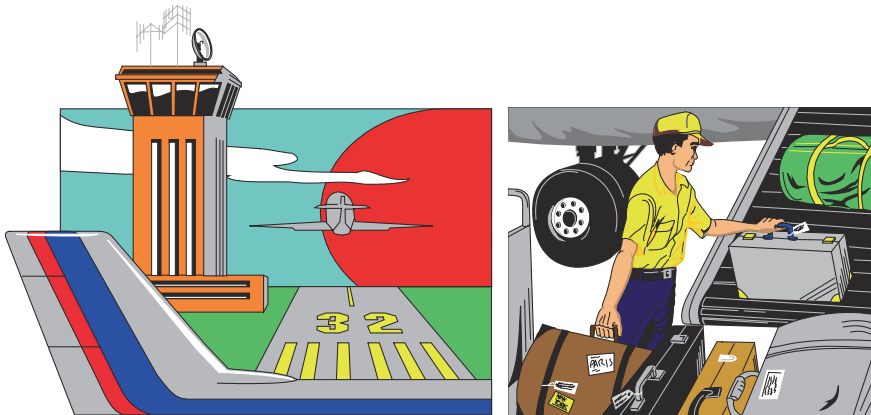

Fig. 1.3 Modern aviation industry assets

1.3 ISO 55000 Series Asset Management Standards

In recent years, a determined effort by those working in the field has resulted in the development of a formal approach to asset management systems, knowledge, and education. This led to the publication in 2014 of the International Standards Organization’s ISO 55000 series of Asset Management standards.¹ These standards supersede the earlier document known as PAS-55, and are complementary to

¹ ISO 55000 Asset management. Overview, principles and terminology. ISBN: 978 0 580 86467 4
 ISO 55001 Asset management. Management systems—Requirements. ISBN: 978 0 580 75128 8
 ISO 55002 Asset management. Management systems—Guidelines for the application of ISO 55001. ISBN: 978 0 580 86468 1.

the International Infrastructure Management Manual.² These developments have been accompanied by the formation of Asset Management professional organizations in many countries. This has acted as a catalyst for the recognition of the key role of asset management in modern organizations and has led to a demand for mainstream education and training in physical asset management.

The ISO 55000 series standards are designed as a guide for organizations involved in establishing, implementing, and maintaining asset management systems and for the planning, design, and implementation of asset management activities.

ISO 55000 gives an overview of the asset management topic and the definitions of terms used.

ISO 55001 specifies requirements for establishing and maintaining an asset management system and for supporting the delivery of asset management activities.

ISO 55002 provides guidelines for the implementation of the requirements specified in ISO 55001.

This book links its main subject matter to the ISO 55000 series of standards and provides examples, exercises, explanations, and discussion to assist in the implementation of the principles involved. It also covers a range of related topics which are important in a business setting. These include financial analysis, budgeting, risk analysis and risk management, and reliability and maintenance management.

Footnotes to various sections in this book give cross references to the corresponding clauses in the ISO 55000 series standards. In addition, Chap. 29 deals specifically with the standards. Section 29.2 gives a detailed series of cross references from ISO 55001 to corresponding chapters, sections, and figures in this book. Section 29.4 discusses the Strategic Asset management Plan (SAMP), which forms a central feature of the documentation required by the standard. Other sections of Chap. 29 assist the reader to relate their own asset management system and its status to the requirements of the standard.

1.4 What is an Asset?

The asset management standard ISO 55000 defines an asset³ as:

an item, thing or entity that has potential or actual value to an organization.

This is a very general definition which can cover any type of asset. To focus our thinking, we can recognize the following types of assets which can normally be identified within organizations:

- Physical Assets
- Financial Assets

² International Infrastructure Management Manual. Association of Local Government Engineering NZ Inc. P.O. Box 118, Thames, New Zealand. www.ingenium.org.nz.

³ ISO 55000 Clause 3.2.1.

- Human Assets
- Information Assets
- Intangible Assets

Physical assets are items such as plant, machinery, buildings, roads, vehicles, railways, aircraft, pipes, wires, communications equipment, and other infrastructure.

Besides physical assets, we also consider financial, human, and information assets to the extent that they support the management of physical assets. Intangible assets are nonphysical things such as goodwill and intellectual property.

1.4.1 Who Needs Asset Management?

Organizations in which physical asset management is of particular importance include all those involving plant, machinery, buildings, roads and bridges, utilities such as electricity, gas and water, transport industries; oil and gas extraction and processing; mining and minerals processing; chemicals, manufacturing, distribution, aviation, and defense.

1.5 Asset Management Role

Asset management sits at a meeting point between the technical and business fields. The role of the asset manager is to bring to bear a combination of technical knowledge and business knowledge in order to effectively and efficiently meet the asset-related needs of the business as a whole. This involves a number of specific areas of professional activity in asset appraisal, asset acquisition, and logistic support over the asset life cycle.

The typical asset manager is likely to be an engineer, maintenance manager, or logistics specialist who has become involved with business decisions, which require both technical knowledge and a financial focus. Asset management is, however, a separate activity from technical engineering and from maintenance management. This is because the practice of engineering or of maintenance management require time, dedication, and a focus which is different from the combination of logistic and business issues involved in asset management.

With regard to other roles in business, finance and accounting specialists are aware of fixed assets as a balance sheet entry whose technical depths are unknown. Information technologists are skilled in establishing data management and communication systems, but the structure, content, and use of the information lie elsewhere.

Senior managers from political, legal, financial, or marketing backgrounds have business priorities and short-term imperatives and must rely on asset managers for sound asset-related advice. And lobbyists for particular solutions may put forward unbalanced views of asset development options.

To the public, debate may rage over the provision of facilities, or issues such as environmental impact, but this rarely involves a balanced appreciation of what

is involved in planning, financing, creating, operating, and maintaining assets. Vocalized or politicized fads and fancies can overwhelm the voice of asset management in the short term, but eventually the realities come home to roost. This book seeks to achieve a holistic view of asset management, which can help create a new generation of professionals in this important field.

1.6 An Accountant's View of Assets

Asset management links closely with financial management and asset managers need to be able to express their opinions in the language of accounting and finance. It is important to recognize the accounting definition of assets, and in particular the split between fixed and current assets. The reason for this distinction lies in how the items are treated from a tax point of view.

1.6.1 Fixed Asset

A *fixed asset* (also called a *non-current asset*) is a physical item which has value over a period exceeding one year, for example, land, buildings, plant, and machinery. When fixed assets are acquired, their cost cannot be counted as an expense for tax purposes in the year of acquisition. When we buy or sell fixed assets we are regarded as having swapped one asset—money—for another asset, a machine, for example. Only the depreciation of the machine in any given year is considered to be an expense in that year. This is important as far as tax treatment is concerned. Planning for the acquisition or disposal of fixed assets involves the Capital Expenditure budget or CAPEX (Fig. 1.4).

Fixed Assets are the physical things that our organization uses in carrying out our business. Examples are, trains and boats and planes; land, buildings, machinery and so on. The distinguishing feature of fixed assets is that they are physical items which normally remain with, and retain value within the organization, for a period of longer than one year.



Fig. 1.4 A fixed asset

1.6.2 Current Asset

Faster moving assets such as: cash; accounts receivable; raw materials, work in process, finished goods, consumables are referred to as *current assets* (Fig. 1.5). Slow moving spares which are normally held for longer than a year should be regarded as fixed assets.

1.6.3 Expense

Expense is money or assets consumed in generating sales or service in the current year. This typically includes wages, materials, and overhead costs. In manufacturing it will comprise the materials and labor that go into making the goods sold in the year, plus administrative costs. It also includes depreciation, which is the proportion of the fixed assets "consumed" in the year. Planning for operating expenses involves the Operating Expense budget or OPEX.

1.6.4 Liabilities

Liabilities are money that we owe. *Short-term liabilities* are amounts that we will need to pay in the immediate future, such as bills for recent purchases or interest or capital payments due in the current year. Loans that we will repay in future years are *long-term liabilities*.

Current Assets are convertible or mobile in nature.

They consist of cash or other financial instruments, and physical items which normally move through the system in less than one year. The following are examples of current assets:

- Cash
- Accounts receivable
- Trade goods,
- Work in process,
- Raw materials,
- Consumables
- Fast moving spares.

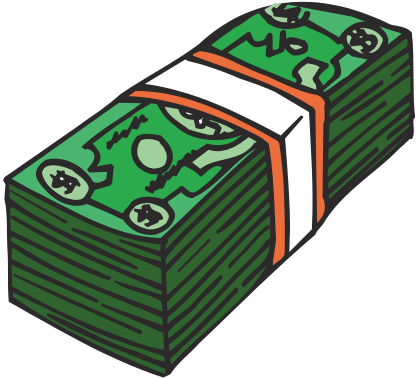

Fig. 1.5 A current asset

Fig. 1.6 Balance sheet

<p>Current Assets: Cash, Receivables, Inventory</p> <hr/> <p>Fixed Assets: Buildings, Plant, Machinery</p>	<p>Short Term Liabilities Accts payable</p> <hr/> <p>Long Term Liabilities Loans</p> <hr/> <p>Equity =Assets-Liabilities</p>
--------------------------------------------------------------------------------------------------------------------------------------------------	---------------------------------------------------------------------------------------------------------------------------------------------------------------

1.6.5 Equity

Equity means the net value of the company after the liabilities are subtracted from the assets. If the result is not a positive number, the company has gone broke. The assets, liabilities, and equity feature in the company balance sheet. Figure 1.6 illustrates this.

1.7 What is Asset Management?

1.7.1 ISO 55000 Definition

The following definition of asset management is given in ISO 55000.⁴

co-ordinated activity of an organisation to realize value from assets.

1.7.2 Extended Definition of Asset Management

If we wish to tell someone what asset management involves, we need a definition that is more informative to the general public than that given in ISO 55000. The following is such a definition:

Given a business or organizational objective, Asset Management is the set of activities associated with:

- identifying what assets are needed,
- identifying funding requirements,
- acquiring assets,
- providing logistic and maintenance support for assets,
- disposing and renewing assets,

so as to effectively and efficiently meet the desired objective.

⁴ ISO 55000 Clause 3.3.1.

From this definition we see that asset management encompasses a broader set of activities than “maintenance”, which is primarily concerned with keeping existing equipment in operating condition. Asset management is concerned with applying technical and financial judgement and sound management practices to deciding what assets we need to meet our business aims, and then to acquiring and logistically sustaining the assets over their whole life, through to disposal.

1.8 Aim of Asset Management

The aim of asset management is to enable the organization to have the assets that are appropriate to its business needs, and to provide supporting services so that these can operate effectively. In more abstract terms, the aim of asset management is to enable an organization to realize value from its assets as it pursues its organizational objectives. Asset management supports the realization of value while balancing financial, environmental and social costs, risk, level and quality of service, and asset performance.

1.8.1 Asset Management System

A basic illustration of the role of physical assets and of asset management within an organization is shown in Fig. 1.7. There we see that the key driver is customer demand which lead to business objectives and business plans. To meet the business objective we need business operations which require the support of physical assets. Asset management works to provide assets to support the business operations. This requires an asset management system⁵ which supports asset planning, acquisition, maintenance, and logistics. Other support services such as information technology, financial and legal services are also required across all the activities.⁶

1.9 The Asset Life Cycle^{7,8}

Figure 1.8 illustrates, in broad outline, the life cycle of a physical asset. The main stages in the life cycle are:

⁵ ISO 55001 Clause 4.4 Asset Management System: “*The organization shall establish... an asset management system...*”.

⁶ ISO 55000 Clause 2.4.2 Fundamentals: “*Asset management is based on a set of fundamentals... This includes...integration with finance, human resources, information systems, logistics and operations.*”.

⁷ Standards Australia AS 4536 Life Cycle Costing.

⁸ ISO 15288:2002 Systems Engineering—System life cycle processes.

Fig. 1.7 Asset management is a support system for a business

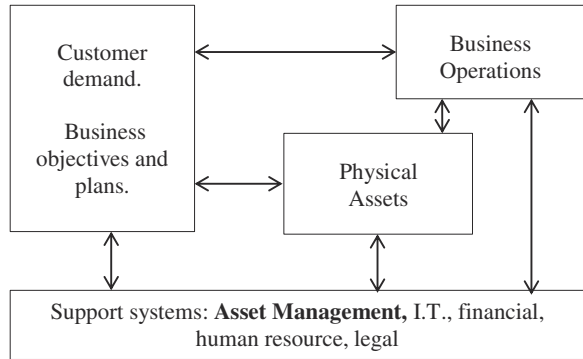
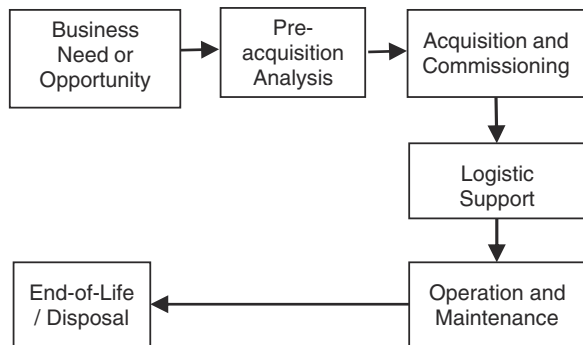

Fig. 1.8 The asset life cycle



- Business Need. Identification of business opportunities or needs
- Pre-acquisition analysis, physical and financial—options selection
- Acquisition, including implementation into operations
- Logistic support provision, such as maintenance facilities, consumables, and spares
- Operation and maintenance
- Disposal.

Asset managers are involved in all aspects of the asset life cycle for the following reasons:

- To assist the organization to identify and acquire the assets needed to support its business aims.
- To provide knowledgeable input into the process of budgeting for the capital and operating costs over the whole asset life cycle.
- To ensure that systems are in place to support the asset over its lifetime.
- To avoid nasty surprises down the track.

1.9.1 Asset Decision Support

The complexity of modern asset-intensive businesses means that a well-developed asset management function is needed to provide support for asset-related decisions. In the area of capital planning and budgeting, or CAPEX, this involves:

- Asset (and associated capability) development planning and implementation
- Asset continuity planning and implementation
- Logistic support facilities development and management
- Business case development for related capital budgets

In the area of operating budget or OPEX it involves decisions related to:

- Organization wide, asset-related systems and procedures, e.g., maintenance facilities, computer systems applications in asset management and maintenance, shut-down/turnaround planning;
- Stock control systems for consumables and spares;
- Development and management of maintenance outsourcing;
- Awareness and management of regulatory compliance;
- Business case development for related operating budgets.

Asset managers need to be able to provide an overview of the asset situation and be aware of factors such as the age and condition of asset fleets, the evolving role of assets in the business, and of developments in terms of technical and service expectations. For examples and further discussion see the chapter entitled “Know Your Assets”.

1.9.2 Regulation

Another factor that creates the need for a professional level of asset management is the rise in regulations, which has grown alongside the increasing complexity of industry. The need for compliance with regulations is an essential feature of modern industry. Regulations apply to many aspects of industrial operations, in such things as health, safety, and environmental impact.^{9,10}

Activities that are impacted by regulation include materials handling and storage, maintenance access, chemicals use or processing, pressure vessels, hot or cold areas, high or enclosed spaces. Design and operation of industrial equipment requires familiarity with the relevant regulatory regimes, and this reflects back on asset acquisition, maintenance, and logistic systems. It is for these reasons that we now need the comprehensive approach to asset management which is addressed by the ISO 55000 standard.

⁹ OHSAS 18001 Occupational health and safety management systems requirements.

¹⁰ ISO 14001 Environmental management system requirements.

1.10 Asset Management Basic Questions

Asset management needs to continuously provide answers to basic questions about any asset, such as:

- Does it work?
- Is it safe?
- Does it support the business aim?

In relation to our business aims have we got the right:

- Equipment by type and location;
- Support facilities, buildings, logistics, and services by type and location;
- Support personnel by quantity and skills?

If not, what should we be doing about it, for example:

Developing a case for activities such as the following and following up with the appropriate level of management:

- Buildings, plant, machinery, equipment: buy or sell, lease or terminate lease;
- Asset support facilities expand, contract, consolidate, relocate;
- Asset support personnel, recruit, reduce, train, outsource, in-source.

1.11 Dangers of Poor Asset Management

In asset intensive businesses it is essential to structure the organization so that the development, acquisition, and operation of the assets are carried out effectively. Business functions, such as Sales, Operations, Finance, and Human Resource Management, may be clearly represented in the business structure, whereas asset management can be a “gray area”, beneath the purview of senior management, but above the level of maintenance. Figure 1.9 illustrates this.

A lack of asset management focus can lead to problems from poor communication between operations and maintenance on the one hand and senior management on the other. This applies to both the understanding of physical situations and to the financial steps needed to address an actual or potential problem.

As an example, a fitter may see a problem of equipment availability, such as when a shortage of tires leads to a loss of availability in a fleet of dump trucks. But from an overall business sense, it is not readily apparent whether this is a temporary problem which it is best to live with, or whether more tires or more trucks are needed. To get the best solution will require analysis of the business operational plan and the asset management plan. Figures 1.10 and 1.11 illustrate this dilemma. The ongoing recurrence of problems of this type indicates the essential role played by the asset manager.

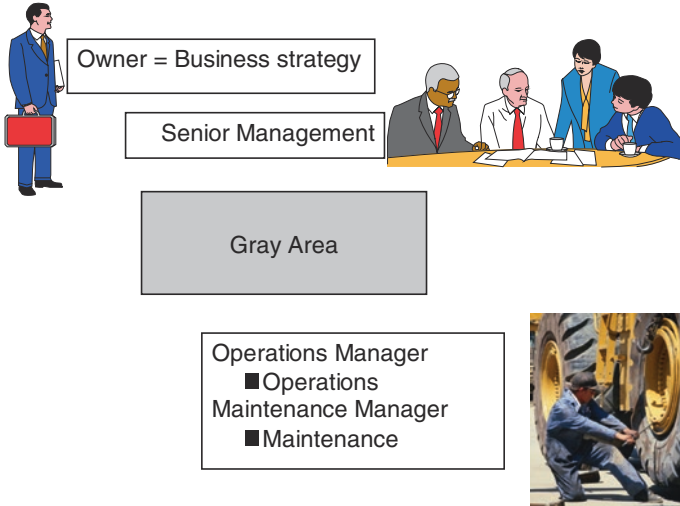

Fig. 1.9 Asset management—a gray area?

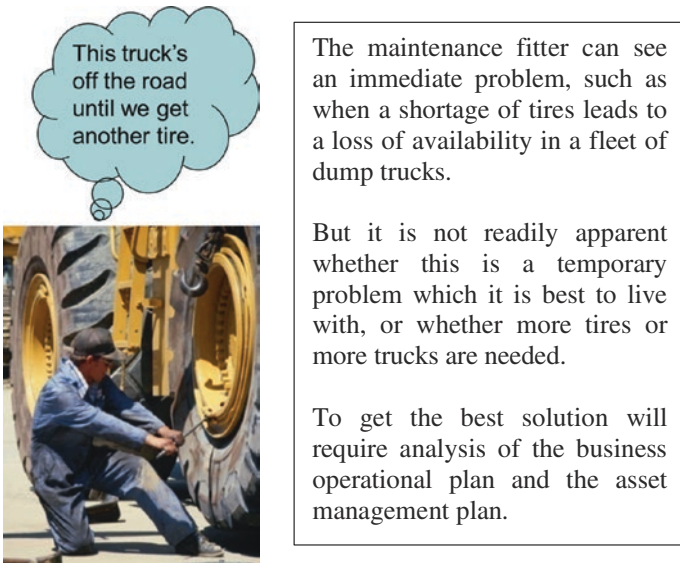

Fig. 1.10 The fitter sees a problem

Successful asset management requires recognition and effective implementation of the functions indicated in the definition of asset management in Sect. 1.7.

The “gray area” of Fig. 1.9 needs to be replaced by the functions shown in Fig. 1.12.



Fig. 1.11 Analysis is needed to get the best business solution

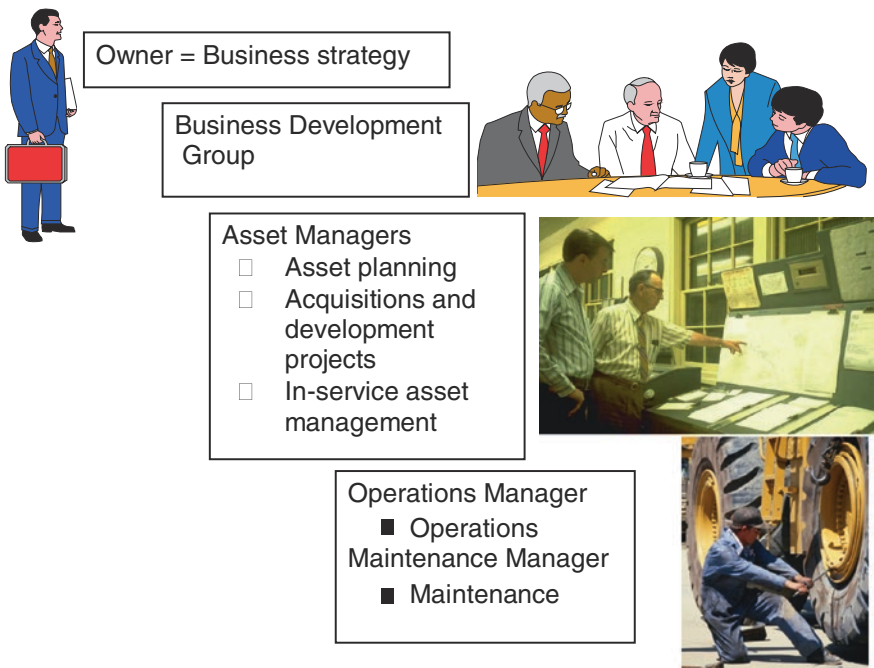

Fig. 1.12 Business activities and asset management

1.12 Benefits of Good Asset Management

Good asset management provides the following benefits which enable an organization to effectively and efficiently deliver business capability, and to achieve its aims in regard to profitability and service delivery:

- A systematic approach to asset-based decisions, so that asset requirements, acquisition, and disposal match the objectives of the business;
- Appropriate logistic support over the asset life cycle, creating improvements in asset performance;
- Effective internal processes for managing assets;
- Benefits in meeting business and regulatory targets, including:
 - operational targets,
 - financial targets,
 - environmental regulations,
 - health and safety regulations,
 - insurance requirements,
 - risk management.
- A systematic framework for the training and development of staff, in understanding and managing the asset portfolio.

The ISO 55000 series of standards provides a general framework for the management of physical assets. The adoption of ISO 55000 can provide:

- A structured view and understanding of asset management;
- Effective relationships between top management, asset management, operations, and maintenance;
- Improvements in asset financial returns;
- Well-informed asset management decisions;
- Insurance, health and safety, regulatory, and risk management benefits;
- Company recognition/marketing;
- Improvements in training and development.

1.13 The Asset Death Spiral

Classic situations have arisen where a plant is central to business profitability, but it is aging—in other words, it is an aging cash cow. Senior managers see no glory in it and the engineers have been redeployed to projects elsewhere. Capital funding is cut and the maintenance budget is cut. Spending on simple problems falls, and in time, simple problems become big problems. Eventually a major accident occurs resulting in fatalities, financial loss, and ignominy for those unfortunate enough to be involved. The situation is known as the Asset Death Spiral and is illustrated in Fig. 1.13.

In Fig. 1.13 initially the plant is running with an appropriate level of budget, which we have shown schematically as being divided between Non-Routine

Fig. 1.13 The asset death spiral

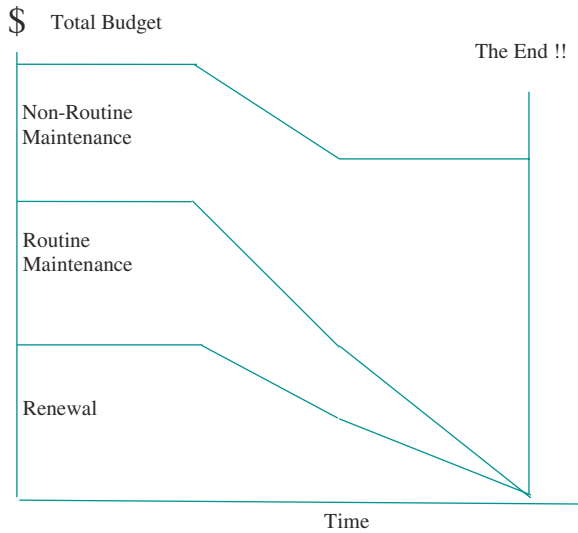

Maintenance, Routine Maintenance, and Renewal. The total budget is then cut, reflecting a perceived reduced importance of the plant. Breakdowns still occur, so non-routine maintenance work must be carried out, but this now requires resources funded from a reduction in expenditure on routine maintenance and/or renewal. This reduction exacerbates the situation, causing more breakdowns, which in turn further reduces the routine and renewal budgets, so that the plant spirals down into a situation where the entire budget is being spent on breakdowns. Eventually the maintenance department is overwhelmed and the plant dies.

1.13.1 Texas City Oil Refinery

In March 2005, an explosion occurred at BP's Texas City oil refinery. 15 people were killed. This was the worst industrial accident in the US for more than 10 years, and led to lawsuits and inquiries. Carolyn Merritt, who chairs the US Chemical Safety Board, said in October 2006 that:

“stringent budget cuts throughout the BP system caused a progressive deterioration of safety at the Texas City refinery”. *The Australian*, 21 December 2006.

1.14 Exercises

1.14.1 Self-Assessment Quiz 1.1

1. Why has Asset Management become more important in recent years than it was 100 years ago?

2. How does ISO 55000 define the word “Asset”?
3. Name five different types of assets that we find in large organizations.
4. Give an example of each type of asset from an organization with which you are familiar.
5. What is the role of asset management in an organization?
6. Why is asset management a separate activity from engineering and maintenance?

1.14.2 Self-Assessment Quiz 1.2

1. What is the difference between a fixed asset and a current asset? Why is this distinction made?
2. What is the ISO 55000 definition of asset management?
3. Give a definition of Asset Management which explains what it is about to someone who doesn't know.
4. What should a manager do if he or she thinks that his area is short of essential equipment or resources?
5. Name six stages in the asset life cycle.
6. Identify four benefits of good asset management.
7. Identify two dangers for an organization that has inadequate resources in asset management.

1.14.3 Gas Processing Plant Exercise

You are the maintenance superintendent of the Longton Gas Processing Plant and you recently attended a presentation on ISO 55000 Asset Management Standards at a local Asset Management Society group meeting.

The following week, the plant manager, a recent appointee in the role, tells a meeting of senior staff that the plant is running smoothly and has a good financial record, but that some cost cutting is needed to support developments on other sites. He says that the engineers currently on-site are being transferred to head office, 220 km away, and that the maintenance budget (CAPEX and OPEX) is to be cut by 10 %.

You are concerned at this. Most of the items of plant are nearing the end of their useful life and maintenance demands are increasing. Although you are familiar with the maintenance of the plant, you rely on the engineers for failure diagnosis and for dealing with nonstandard conditions that occur when component change-outs or shutdowns are required. You plan to express these concerns to the plant manager.

Prepare a series of dot points that you intend to cover in your meeting with the plant manager.

1.15 Solutions to Exercises

1.15.1 Self-Assessment Quiz 1.1

1. *Why has Asset Management become more important in recent years than it was 100 years ago?*

The complexity of modern asset-intensive businesses means that a well-developed asset management function is needed to provide support for asset-related decisions.

2. *How does ISO 55000 define the word “Asset”?*

ISO 55000 defines an asset as “an item, thing or entity that has potential value to an organization.”

3. *Name five different types of asset that we find in large organizations.*

Five types of assets are:

- Physical Assets
- Financial Assets
- Human Assets
- Information Assets
- Intangible Assets

4. *Give an example of each type of asset from an organization with which you are familiar.*

You will need your own solution for this one.

5. *What is the role of asset management in an organization?*

The role of asset management is to effectively and efficiently meet the asset related needs of the business as a whole, by bringing to bear a combination of technical knowledge and business knowledge. This involves a number of areas of professional activity in asset appraisal, asset acquisition, and logistic support over the asset life cycle.

6. *Why is asset management a separate activity to engineering and maintenance?*

Because the practice of engineering or of maintenance management both require time, dedication, and a focus which is different from the combination of logistic and business issues involved in asset management.

1.15.2 Self-Assessment Quiz 1.2

1. *What is the difference between a fixed asset and a current asset? Why is this distinction made?*

A *fixed asset* (also called a *non-current asset*) is a physical item which has value over a period exceeding 1 year, for example, land, buildings, plant, and machinery. Faster moving assets such as: cash; accounts receivable; inventory (materials, work in process, finished goods, consumables) are referred to as *current assets*. The reason for this distinction lies in how the items are treated from a tax point of view.

2. *What is the ISO 55000 definition of asset management?*

The following definition of asset management is given in ISO 55000

co-ordinated activity of an organisation to realize value from assets.

3. *Give a definition of Asset Management which explains what it is about to someone who doesn't know.*

“Given a business or organisational objective, Asset Management is the set of activities associated with:

- identifying what assets are needed,
- identifying funding requirements,
- acquiring assets,
- providing logistic and maintenance support systems for assets,
- disposing or renewing assets,

so as to effectively and efficiently meet the desired objective.”

4. *What should a manager do if he or she thinks that his area is short of essential equipment or resources?*

Develop a case for activities such as the following and follow-up with the appropriate level of management:

- Buildings, plant, machinery, equipment: buy or sell, lease or terminate lease,
- Asset support facilities expand, contract, consolidate, relocate,
- Asset support personnel, recruit, reduce, train, outsource, in-source.

5. *Name six stages in the asset life cycle.*

- Business need. Identification of business opportunities or needs.
- Pre-acquisition analysis, physical and financial—options selection
- Acquisition, including implementation into operations
- Logistic support provision, such as maintenance facilities, consumables, and spares
- Operation and maintenance
- Disposal.

6. *Identify four benefits of good asset management.*

Any of the following:

- A systematic approach to asset-based decisions, so that asset requirements, acquisition, and disposal match the objectives of the business.
- Appropriate logistic support over the asset life cycle, creating improvements in asset performance.
- Effective internal processes for managing assets.
- Benefits in meeting business and regulatory targets, including:
 - operational targets,
 - financial targets,
 - environmental regulations,

- health and safety regulations
- insurance requirements
- risk management.
- A systematic framework for the training and development of staff, in understanding and managing the asset portfolio.

7. *Identify two dangers for an organization which has inadequate resources in asset management.*

A lack of asset management resources can lead to poor communication between operation and maintenance on the one hand and senior management on the other. This applies to both the understanding of physical situations and to the financial steps needed to address an actual or potential problem.

1.15.3 Gas Processing Plant Exercise

Dot points to cover in your meeting with the plant manager.

- (a) The plant is nearing the end of its useful life and maintenance demands are increasing.
- (b) Budget cuts will decrease maintenance effort and will accelerate the decline, which will mean more outages and safety risks.
- (c) Asset continuity and renewal planning are needed now.
- (d) I cannot tackle this as maintenance needs my full attention.
- (e) The engineers who might have been a resource for asset management are leaving.
- (f) Technically, the engineers are needed to support nonstandard operating and maintenance issues.
- (g) The profit from the plant means that investment in it should continue.
- (h) An asset death spiral could result in an accident and major production loss.

1.16 A Top Level Decision

Jock and Sheila were lying in bed one Sunday morning when Jock reached for an envelope that had been lying on the bedside table for a couple of days. He knew what it contained.

“We need to renew the lease on this place,” he said. Sheila said nothing, which Jock realized was an ominous sign.

“We have to live somewhere,” he ventured, but the silence continued. She must be ahead of him on some other track.

“I’m going to go off the pill next month,” Sheila said.

Jock and Sheila had discussed having a family and had agreed that it was what they both wanted. Obviously, going off the pill was a necessary start, but why bring it up now? And what did it have to do with the lease on the flat? Then Jock had a blinding insight.

At the beginning of the year he had moved out of the maintenance department of the industrial conglomerate where he worked, and got a job in Asset Management. He didn't know what asset management was, but he liked the sound of it, and more importantly, the job offered a rise in his pay.

It was the asset management perspective which made him realize that his and Sheila's Sunday morning sports session had morphed into a Business Development Meeting.

"There are some house blocks just released in Mullum Gully," said Sheila.

"We could go and look at them this afternoon," said Jock. Sheila smiled.

Chapter 2

Structure and Activities

Abstract To describe how asset management fits into the structure of an organization and to summarize the activities involved in asset management. *Outcomes* After reading this chapter you will know about:

- The link between asset management and business strategy, including the factors involved in business development which impact on asset strategy;
- The role of the Chief Asset Management Officer;
- How the asset management function should be structured;
- The role of asset management groups which have personnel working in particular technical areas;
- The basic knowledge required by asset managers;
- The main activities of asset management;
- Organizational activities which are not part of asset management;
- The need for financial, legal, and engineering support for asset management;
- What is meant by an asset management policy and an example related to ISO 55001;
- An introduction to asset management plans with reference to ISO 55001.

2.1 Business Strategy and Asset Management¹

The purpose of Asset Management is to provide resources and expertise to support the identification, acquisition, in-service support, and disposal of the physical assets required by the organization. The asset strategy must be responsive to and interact with the business strategy.

¹ ISO 55001/2 Clause 4.1 Understanding the organization and its context.
“The organization shall determine issues...that affect... its asset management system”
“Asset management objectives... shall be aligned to... organizational objectives.”

The asset management function must link into the strategic issues deriving from the business situation which will impact on asset management plans. Developments in the business/asset situation typically include the following:

- Trends in demand for product or service.
- Trends in the type or level of product or service required.
- Changes in revenue, costs or profitability, for example, due to competition.
- Opportunities for new business and/or business development
- Technological developments
- Asset capability gaps—gaps in capacity and/or ability in delivering all aspects of the required asset role.
- Timing issues—when the assets are required and what lead times are involved
- Acquisition strategies, supplier options
- Age and remaining life of existing assets
- Regulatory limitations, opportunities, or changes
- Condition of assets—providing adequate service level, reliability, availability?
- Risk factors for availability, capacity, health, safety, and environment issues.
- Business acquisitions.
- Divestment, sale, or phasing out.
- Redeployment of assets.
- Changed operating practices.
- Equipment replacement/leasing decisions.
- Outsourcing or in-sourcing of services or functions.

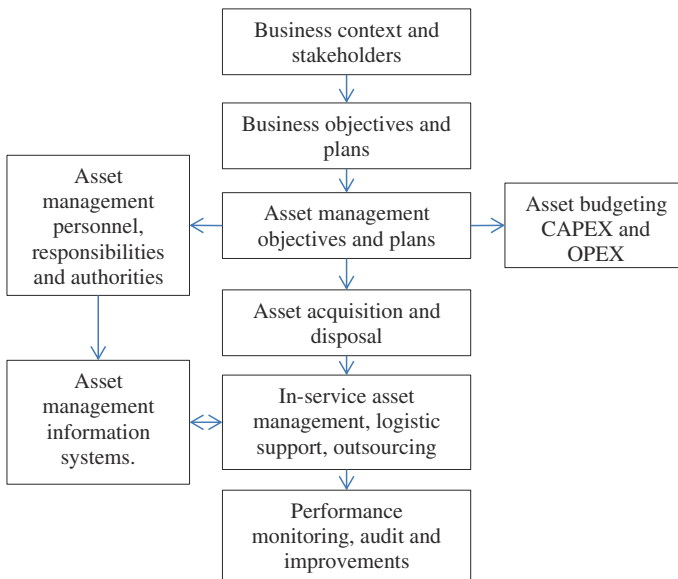
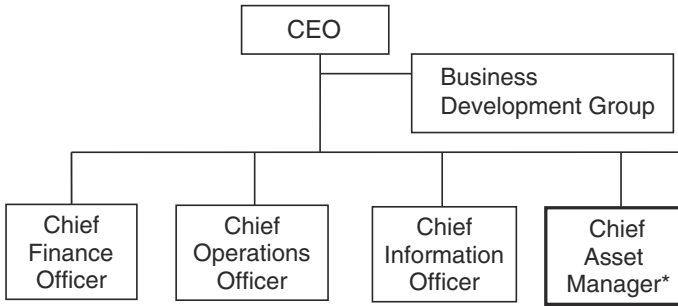

Fig. 2.1 Asset management in the business context



* Title may vary to cover the Asset Management / Engineering / Logistics / Planning functions but representation at ‘Chief’ level is important.

Fig. 2.2 Asset management in the organization

A flowchart of the asset management system in relation to the business context is shown in Fig. 2.1.²

2.2 Asset Management in the Organization

A central asset management function is needed at company level, to provide inputs to asset planning, to take a role in major acquisitions and developments and to be involved in the provision of the systems and facilities needed to support assets throughout their life. Asset management is distinct from operations, and does not usually involve the direct design or building of the assets themselves. The exact terminology and reporting structures may vary from organization to organization. Figure 2.2 shows an example of how the senior level of an organization may look.

2.3 Chief Asset Manager Role³

An essential step toward successful asset management is to recognize asset management as an activity which requires representation at senior level. This is illustrated in Fig. 2.2. The precise title may vary, and what we have referred to here

² Figure 2.1 illustrates the alignment of business and asset management objectives as required in ISO 55001/2 Clause 4.1.

³ ISO 55001 Clause 5.3: “Top management shall assign the responsibility and authority for...

- Ensuring the... effectiveness of the asset management system
- Establishing ... asset management plans
- Reporting on asset management performance....”

as a Chief Asset Manager may have a title which refers to or includes planning, logistics, or engineering. The important thing is that representation at the Chief level allows asset management to play its key role in asset-related decisions and activities. This includes the following responsibilities of the Chief Asset Manager:

- Conveying the asset implications of the organization’s business objectives and plans to senior management. This will involve participation by the Chief Asset Manager in the Business Development Group which appears at high level in Fig. 2.2, reporting to the CEO.
- Developing physical plans and financial proposals for asset-related capital and operating expenditure.
- Taking responsibility for the many activities that assets require in an asset intensive organization.

If asset management decisions fall between, on the one hand, senior managers whose background gives them little appreciation of the physical state of the company’s assets in relation to needs, and on the other hand, technical personnel who are too junior within the organization, or too inarticulate in business terms to state their case, then financial and operational disasters can follow. The Chief Asset Manager provides a clear single line of authority and ownership for asset management issues. This covers:

- Asset management groups which specialize in dealing with particular families of assets,
- Asset-related financial and administrative staff,
- Maintenance and related technical services,
- Engineering.

2.4 Asset Management in the Organization (2)

The existence of a Chief Asset Manager does not mean that all asset management activity is concentrated at the top level. Operating divisions may have asset managers looking after their own assets, just as they have information technology and accounting staff looking after their own divisional activities in those areas. Asset management skills and awareness⁴ are needed in many roles, and not just by persons who are labeled “Asset Manager.” At the risk of some ambiguity, we shall use the term Asset Manager to cover both a person employed *primarily* in asset management activities and a person who uses an asset management approach in tackling issues which are only part of their overall job. However, company-wide issues, policies, strategies, systems, and procedures need to be coordinated from the higher level, and we shall assume the existence of a group which we shall refer

⁴ ISO 55001 Clause 7.3 Awareness: “Persons... shall be aware of...policies...benefits...risks...”

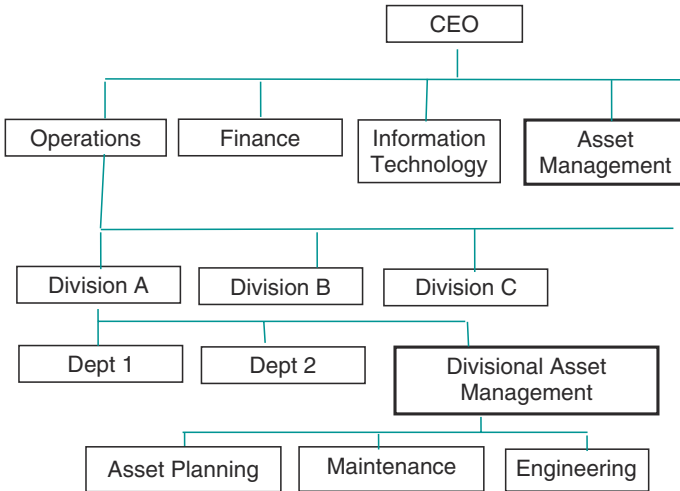

Fig. 2.3 Asset management in the organization (2)

to as the asset management group, recognizing that other names may be used in various organizations. Figure 2.3 illustrates how asset management at the divisional level can combine with asset management at the chief officer level.

2.5 Asset Management Groups

Asset management activities and responsibilities impact on a wide range of roles within an organization and are not confined to a specific department. However, in a large organization, effective asset management will benefit from the existence of recognized asset management personnel with expertise in specific areas. These may be formed into distinct groups, the title of which will depend on the technology and the company structure.

The purpose of an Asset Management Group is to provide resources and expertise to support the identification, acquisition, in-service support, and disposal of a particular group of physical assets required by the organization.

An example in defence is the Australian Defence Materiel Organization. This has divisions managing land, sea, and air assets. Within each division are asset management groups referred to as System Program Offices (SPOs). Each SPO manages a particular group of prime assets, such as a type of ship or aircraft and all the associated subsidiary assets. In a civilian airline, groups will correspond to the main aircraft types, with additional groups for ground handling equipment, sales systems, and operations systems.

An asset management group consists of asset managers with suitable technical backgrounds, with support from personnel in accounting and finance, legal, and

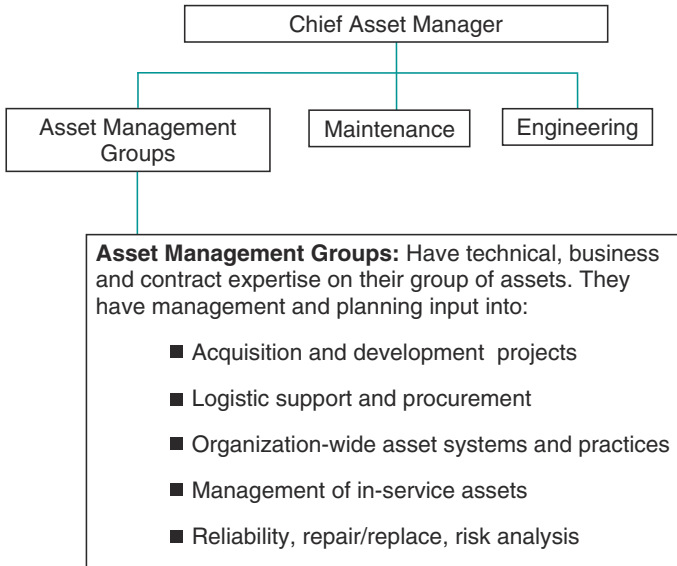

Fig. 2.4 Asset management group structure

contracting roles. Financial, legal, and engineering staff may be colocated to asset management groups from their professional area. For particular projects, teams will be formed with personnel numbers and skills dependent on the content and size of the project. The asset management groups form a basis from which these teams can be formed.

The asset management groups have key roles in acquisition and development decisions, acquisition and development projects, and in creating and managing organization-wide systems for equipment support for new and existing assets.

Figure 2.4 illustrates this structure. An asset management group can involve hundreds of personnel in a large organization. In a smaller organization, the same types of tasks are undertaken and the same types of decisions are made, so that the logic of the processes carries through, even though the tasks may be handled by, say, a works manager, a works engineer, or a maintenance manager in among a range of other commitments.

2.5.1 Asset Management Groups Example

Asset management groups are based around the various major equipment areas operated by a company. Figure 2.5 shows an example of the asset management groups for an electricity transmission company. The company installs and operates transmission lines and substations. There are asset management groups for “substations”

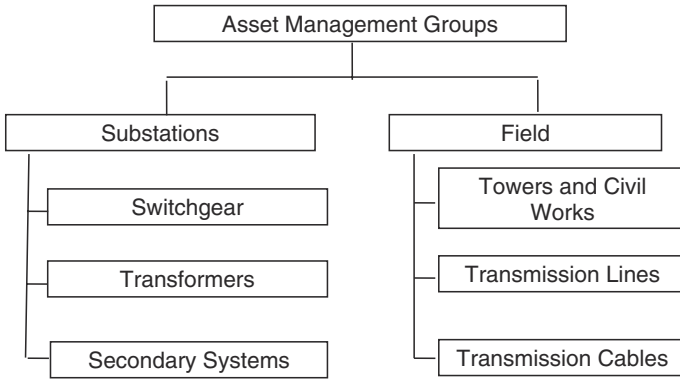

Fig. 2.5 Asset management groups example—electricity transmission

and “field” with subgroups for switchgear, transformers, transmission lines, and so on. Each group is headed by an asset group manager, supported by technical, logistics, financial, and commercial staff with competence in the particular field.

2.6 Integrated Project Teams

An integrated project team is a team which is formed to manage a major project. The team may typically be led from the most closely related asset management group, or from the business development group. The team will draw on asset management personnel, augmented by financial, contract, and engineering specialists as necessary. These specialists may be involved with a particular project team on a full-time or part-time basis depending on the amount of work required. A team may include representatives from stakeholder groups.

Asset management groups often have primary responsibility for projects of a wide range of types. Project teams may bring in staff members from other asset management groups where multiple technologies are involved.

2.7 Asset Knowledge⁵

The management of assets is dependent on knowledge about the organization’s assets. This involves knowledge of the current equipment in terms of its technology, deployment, condition, and business role. It also involves knowledge of

⁵ This section is relevant to ISO 55001/2 Clause 4.3 “Determining the scope of the asset management system.”

Table 2.1 Asset management knowledge

1	What assets have we got
2	Where are they located
3	What is the business significance of our major assets
4	What is the profit and loss position of our major assets
5	What is our asset utilization including peak load and seasonal factors
6	Are there gross imbalances—that is, major shortages, surpluses or misallocations of equipment or personnel
7	What is the condition of each major asset
8	Are reliability or availability issues significant
9	How much longer can specific assets last
10	Are there significant risks
11	Are maintenance costs a significant factor
12	What asset related developments and market opportunities exist
13	What has the market got to offer in terms of assets that we might usefully acquire

potential future developments. Asset managers need to have a practical working knowledge of the major assets at a management level, so as to be able to make sound business decisions. They need to be aware of the assets which constitute elements in any given capability, that is, the array of subsidiary items which are necessary to support particular prime equipment. There is also a requirement for *configuration management*, that is, keeping systematic track of changes to equipment configurations, such as technical upgrades and regulatory compatibilities.

For major items for which future capital decisions are required, it is advisable to list the date and type of the decisions that will be needed. For example, for a truck fleet, we need knowledge of the years of remaining effective life of vehicles, and of the lead time for acquisition of replacements, so that we can plan our replacement strategy sufficiently far in advance. This knowledge, combined with an assessment of the future requirements of the business, and of developments in the types of equipment available from manufacturers, will enable us to make sound and timely decisions within the constraints of business risk. A summary of points of knowledge which an asset manager needs to have is shown in Table 2.1.

2.8 Asset Management Activities

A life cycle diagram is shown in Fig. 2.6, giving more detail than the outline in Chap. 1. We shall use this cycle in considering the various activities of asset management. The main steps in the cycle are as follows:

- Identification of business opportunities or needs
- Asset capability gap analysis and requirements analysis
- Pre-feasibility analysis, physical and financial—options selection

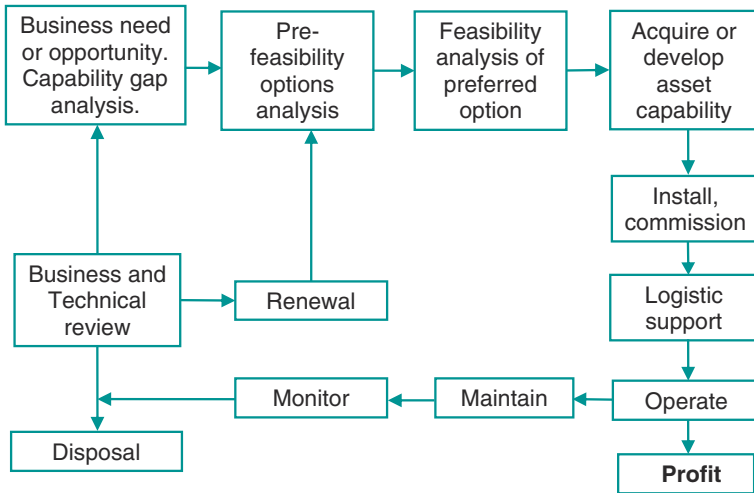

Fig. 2.6 The asset life cycle

- Feasibility planning, physical and financial—for selected option
- Acquisition, development, and implementation
- Operation, maintenance, and logistic support
- Monitor and review
- Disposal.

However, *operations* and direct *maintenance* work are not asset management activities.

2.8.1 Deployed Assets and Asset Fleets

Deployed assets are those currently in-service with the organization. Deployed assets of a given type can be conveniently referred to as the “fleet” of that type of asset. A life cycle diagram such as Fig. 2.6 indicates the cycle through which any particular fleet will pass. However, at any given point in time the deployed assets will consist of numerous fleets of assets of different types and these fleets will be at different stages of their life cycles. Asset management activities are required to work across all the asset fleets currently in-service. The whole picture is therefore more complex than may be inferred from considering any particular fleet in isolation.

The asset management function has a role to play in relation to a substantial number of activities, as shown in Table 2.2 Asset Management Activities. Many of these activities will be considered in detail later in the book.

The following subsections further describe some of the activities of asset managers.

Table 2.2 Asset management activities

1	Input to asset-related aspects of business development at the concept planning stages
2	Input to pre-feasibility and feasibility analysis for asset developments including requirements analysis, input to financial analysis
3	Development of recommendations for acquisitions, process improvements, replacement, refurbishment
4	Preparing business cases for asset-related activities; can include preparing proposals, evaluating proposals, and advising on the preparation of proposals
5	Preparation of asset-related input to Capital Budgets (CAPEX) and Operating Budgets (OPEX)
6	Life cycle costing
7	Management of asset acquisition and/or development projects
8	Development and implementation of logistic support policies
9	Management of introduction into service
10	Setting maintenance policy and procedures, e.g., via reliability centered maintenance
11	Applications of asset-related technology, e.g., new equipment developments, condition monitoring developments
12	Managing asset policies in regard to health, safety, environment, security requirements
13	Managing through life support provision, effectiveness, and audit
14	Maintenance facilities and resources planning and provision
15	Maintenance outsourcing strategy and management
16	Configuration management
17	Input into the selection, implementation, and user support for asset management information systems
18	Technical input into computerized asset management information systems structure and development, including identification and coding
19	Asset register updating
20	Asset renewal/replacement/overhaul policy assessment and decisions
21	Arrange and carry out reliability and availability tests and evaluations
22	Equipment redeployment for asset management reasons
23	Equipment disposal
24	Asset-related special studies
25	Asset implications of changed operating practices.
26	Equipment leasing policy and management
27	Identifying and setting asset-related emergency response strategies
28	Incident reporting systems, fault and failure reporting systems and responses, root cause failure analysis
29	Spare parts management systems and spares control setting including rotatable repair parts policy and management, insurance spares
30	Pilot studies and trials organization and evaluation
31	Liaising with stakeholders on asset-related topics
32	Asset condition assessment and recording
33	Asset valuation
34	Change management

(continued)

Table 2.2 (continued)

35	Decisions on the implementation of modifications and technical improvements
36	Cost–benefit analysis
37	Geographic information systems introduction, implementation
38	Asset physical identification
39	Repair/replace policy and related decisions
40	Level of repair analysis

2.8.2 Capital Items

Asset acquisition plans are to be created and to be reviewed annually, both for asset replacement and as required in the event of business developments. The age and condition of assets is to be monitored and taken into account in planning, so that issues of reliability and risk, and disruptions to business plans are minimized.

Capital expenditure (CAPEX) proposals are to be prepared in accordance with the organization’s standard procedures and timings, and will include a financial and/or cost–benefit analysis and a risk analysis.

2.8.3 In-service Support

A systematic approach to the support of in-service assets is to be established and operated in accordance with the following requirements:

Asset maintenance plans, which may include outsourcing, are to be established and to be documented in the organization’s maintenance management computer system. Plans will be implemented to deliver the required level of service of assets. Asset maintenance plans are to minimize life cycle costs consistent with achieving the outcomes specified.

Asset-related operating expenditure (OPEX) proposals are to be prepared in accordance with the organization’s standard procedures and timings. Procedures for managing the resulting asset management and maintenance operating budgets are to be established and followed.

Risk analysis of asset operations is to be undertaken in accordance with specified procedures. Risk management and mitigation strategies are to be implemented as indicated by the analysis.

The specified information management system is to be used for recording plans, procedures, and work management.

Developments in systems specifications, data structures and applications, such as GPS systems, asset coding, and identification will be undertaken as required.

Reporting procedures for asset-related incidents, failures, or defects and procedures for the analysis and response to these are to be established and intelligently followed.

Definitions and reporting procedures for asset performance indicators are to be created, applied, and monitored.

Other factors to be considered are plans for the longer term; the degree of commitment to in-house repair and logistic support as opposed to use of outsourced support facilities; the use of redundancy to achieve system reliability rather than seeking high reliability of individual items; the degree of coordination between related parts of a supply chain, e.g., electricity generation, transmission, and distribution; maintenance and replacement strategy in regard to run-to-failure, age-based, condition-based, spend-limit-based replacement decisions.

2.9 Asset Management Policy

A policy statement is a statement of the overall aims or principles adopted by an organization. A policy statement provides high level direction, aimed at guiding the business decision-making process.

ISO 55001 requires an organization to state an asset management policy.⁶ The policy is required to provide a basis for setting asset management objectives to include a commitment to meeting asset requirements and a commitment to continuous improvement. Some suggested general points to be covered in the asset management policy statement are shown in Fig. 2.7.

Other policy principles relate to business governance and practice, and may be in the form of references to other relevant documents. An example is procedures for ensuring a transparent choice of suppliers or service providers. However, we may also specify that interests of logistic support allow selection from a limited range of providers. Another example is that work is to be carried out in accordance with relevant legislation, standards and guidelines, including health, safety, and environmental protection. Policies in relation to outsourcing and the retention of specific sets of skills within the organization may be established.

High-level responsibilities may also be established under the Policy heading, for example, the role of the company board in approving and monitoring capital asset acquisition plans and reviewing asset performance.

2.10 Asset Management Plans

A major activity of the asset management group is the development of asset management plans. ISO 55000⁷ defines an Asset Management Plan as:

⁶ ISO 55001 at Clause 5.2 Policy: “Top management shall establish an asset management policy.”

⁷ ISO 55000 Clause 3.3.3 Asset management plan definition.

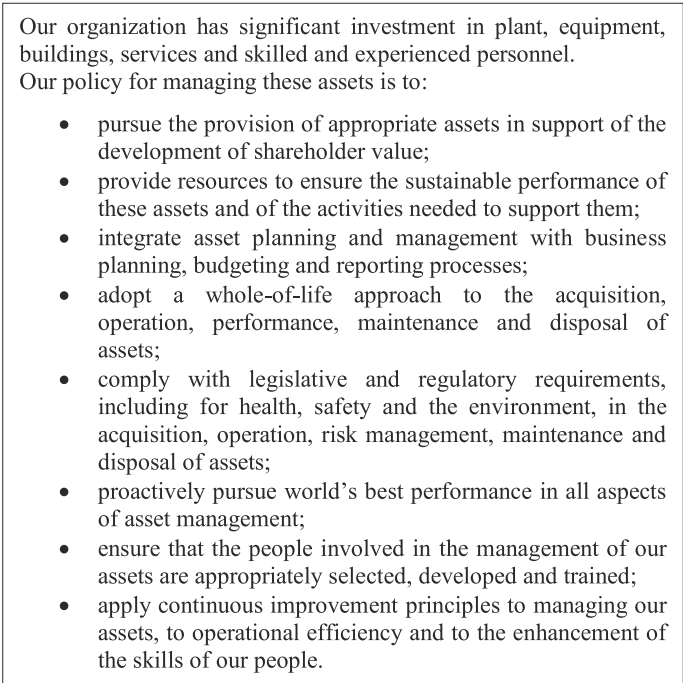

Fig. 2.7 An asset management policy statement

“documented information that specifies the activities, resources and timescales required for an individual asset or a grouping of assets, to achieve the organization’s asset management objectives.”

An Asset Management Plan is a plan that involves specifying:

- Activities
- Resources
- Timescales
- Responsibilities

that are required for the asset or group of assets to achieve specified objectives. Plans are based on the maintenance, repair, overhaul and replacement activities and logistic support needed to sustain the assets and to enable them to deliver the expected level of service over a specified timescale.

Details of the asset management planning process for individual assets or groups of assets, and for the creation of consolidated, planning-period based, asset management plans across a portfolio of assets are considered in detail in later chapters.

2.11 Strategic Asset Management Plan (SAMP)

A Strategic Asset Management Plan (SAMP) is a document which describes how asset management is organized and operated within the organization. ISO 55001 states⁸ that organizations “shall develop a SAMP”. The SAMP is also referred to in numerous clauses of the standards. The SAMP will be discussed in detail in a later chapter.

2.12 Policy, Strategy, or Plan?

“I don’t get it,” said Jock to his offsideer Veronica as they wandered to the water cooler. “What’s the difference between a policy, a strategy and a plan?”

“Here comes Nick. Maybe he can explain it—he’s sure to have an opinion, even if it’s wrong!” said Veronica.

“Wrong, me?” said Nick, approaching.

“We don’t want any of your World War 2 stuff,” said Veronica.

Nick thought for a minute.

“Okay, let’s try the Punic War,” he said.

“Puny war?” said Jock.

“Punic—between the Romans and the Carthaginians around 200 B.C.” said Nick.

Veronica put on a pained expression.

“Let’s start with Policy,” said Nick. “That’s a statement of an overall aim or principle. The Roman policy was stated by Senator Cato, “Carthage must be destroyed.” An alternative policy might have been for Rome and Carthage to form some kind of Mediterranean Union. But Rome wanted it all, hence the motto *mare nostrum*.”

“I warned you he was a smarty pants,” said Veronica. “Anyway, how do you know that destroying Carthage was a Policy? It might have been an Objective!” (Fig. 2.8).

“Either way, it seems to have worked,” said Jock. “Where was Carthage anyway?”

“It was in North Africa,” said Nick.

“So the Romans had a policy or maybe an objective, but what about a strategy?” said Jock.

“Hannibal, the Carthaginian general, had a strategy based on taking his army around Spain and across the Alps into Italy, aiming to defeat the Romans there,” said Nick.

“I remember the bit about the elephants crossing the Alps,” said Jock. “I read that the climate must have been warmer in those days, otherwise he would never have made it.”

⁸ ISO 55001 Clause 4.4.

Fig. 2.8 Carthage must be destroyed



“The Roman general had a different strategy,” said Nick. “He took his army across the Med. by boat and captured Carthage”.

“It seems that was the best strategy,” said Jock, “but what about a Plan?”

“A plan is more a matter of detail. It’s about the activities, resources and timings needed to put something into practice,” said Nick.

“ISO 55000 talks about a Strategic Asset Management Plan,” said Veronica, switching to a more current issue, “but is it a Strategy or a Plan? What do you reckon?”

“Maybe the guys that wrote this stuff weren’t too particular about the distinctions,” said Jock, leafing through the ISO 55000 documents. “Look at this in ISO 55002 Clause 4.1.1.1. ‘NOTE 2: A strategic asset management plan can be referred to by other names, e.g. an asset management strategy’. So someone must have thought the SAMP was a strategy and not a plan...but then, going down another paragraph it says ‘The links between the organizational plan and the Strategic Asset Management Plan should be two-way, and should be developed through an iterative process’. That sounds like a plan—or maybe just a two-way bet!”

“It looks like we’re going to have to live with some flexibility,” said Nick. “A lot of people just use these terms interchangeably, and any particular document might be a combination of policies, strategies, plans and budgets.”

“Talking about budgets, there’s another thing,” Nick went on. “All this strategy and planning is going to depend on there being a budget to actually do something. The overall picture is in Fig. 2.9. We’ll see more about the budgeting aspect later in the book.”

Fig. 2.9 Policy, strategy, plan and budget

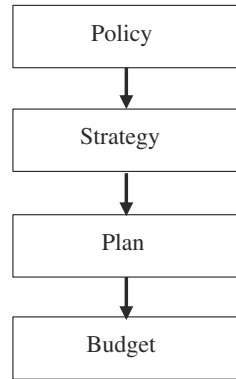

2.13 Exercises

2.13.1 Self-Assessment Quiz 2.1

1. Identify five factors which can affect business strategy and which can then impact on asset management plans.
2. Identify three key responsibilities of a Chief Asset Manager.
3. What is the purpose of an asset management group?
4. Under what circumstances will an integrated project team be formed and what type of persons will be involved in it?
5. Identify six items of asset knowledge relevant to the asset management role.

2.13.2 Self-Assessment Quiz 2.2

1. List six activities in which asset management is commonly involved.
2. Identify three areas of activity where asset management does NOT have a leading role.
3. What is meant by an asset fleet?
4. Identify three topics that an asset management policy should address.
5. What will the asset management plan for an individual asset or group of assets be based on?

2.13.3 Holiday Resort Exercise

The owners of a holiday resort have had a good year, but at times the resort was overcrowded. There are opportunities to develop additional areas for leisure activities and accommodation. Write down half a dozen dot points of factors that they should consider in making plans for the future.

Alternatively, make a similar analysis related to an organization in a field with which you are familiar.

2.14 Solutions to Exercises

2.14.1 Self-Assessment Quiz 2.1 Solution

1. *Identify five factors which can affect business strategy and which can then impact on asset management plans.*
Any five of the dot points in Sect. 2.1.
2. *Identify three key responsibilities of a Chief Asset Manager.*
The three dot points under Sect. 2.3.
3. *What is the purpose of an asset management group?*
The purpose of an Asset Management Group is to provide resources and expertise to support the identification, acquisition, in-service support, and disposal of a particular group of physical assets required by the organization.
4. *Under what circumstances will an integrated project team be formed and what type of persons will be involved in it?*
An integrated project team is a team which is formed to manage a major project. The team may typically be led from the most closely related asset management group, or from the business development group. The team will draw on asset management personnel, augmented by financial, contract, and engineering specialists as necessary.
5. *Identify six items of asset knowledge relevant to the asset management role.*
Any six items from Table 2.1, Asset management knowledge.

2.14.2 Self-Assessment Quiz 2.2 Solution

1. *List six activities in which asset management is commonly involved .*
Any six items from Table 2.2.
2. *Identify three areas of activity where asset management does NOT have a leading role.*
Operations, Equipment design or construction, Maintenance (direct activities).
3. *What is meant by an asset fleet?*
A “fleet” of assets is the deployed assets of any given type.
4. *Identify three topics that an asset management policy should address.*
Any three of the dot points in Fig. 2.7.
5. *What will the asset management plan for an individual asset or group of assets be based on.*
The plan will be based on the life cycle maintenance, repair and overhaul activities, and logistic support needed to sustain the asset and to enable it to deliver the expected level of service over its lifetime.

2.14.3 Holiday Resort Exercise Solution

The owners of a holiday resort have had a good year, but at times the resort was overcrowded. There are opportunities to develop additional areas for accommodation and leisure activities. Write down half a dozen dot points of factors that they should consider in making plans for the future.

- a. History of demand, level, trend, cycles, forecast of customer demand.
- b. Demographic pattern of current and potential customers.
- c. Possible bottlenecks and easy fixes? Access roads, parking, buses, airport.
- d. Site analysis.
- e. Scope for new attractions (e.g., theme parks) with considerations of capacity, accessibility, match to customers' interests.
- f. Scope to develop new accommodation.
- g. Needs for additional utilities and services, e.g., power, access routes, parking, staffing, training, staff accommodation.
- h. Outline of practical options with preliminary financial analysis.
- i. Ranking of best return on investment.
- j. Requirement for government approval and permits if any.
- k. Risks, e.g., Accuracy of demand forecasts; Attitude to expansion of locals, of government; environmental impact, variability of weather; Risk of the unknown!
- l. Competitor analysis.
- m. Marketing required for selected option.

Chapter 3

Asset Management Personnel

Suffer fools gladly—they may be right.

Abstract To describe the matrix nature of asset management, the need for liaison with many groups, and the need to understand the context of the organization and its stakeholders. To indicate the competencies needed by people who work in asset management. To describe how the asset management system should plan for competency in asset management roles. *Outcomes* After reading this chapter you will know about:

- Matrix management nature of asset management and areas with which liaison is needed
- The definition of competence
- Competencies needed in asset management
- Filling competency gaps
- Key activities where competence is needed
- Personnel roles in asset management and related engineering and maintenance roles
- Personnel development
- Competency assessment
- Leadership
- Communication

3.1 Asset Management—A Matrix Activity

Asset management is a matrix activity which links with many areas of the business. Asset management involves ongoing liaison with diverse areas and Fig. 3.1 illustrates this. Asset managers need a range of knowledge and communication skills which enable them to deal with these interfaces. They need to combine a significant degree of technical equipment knowledge with the ability to communicate

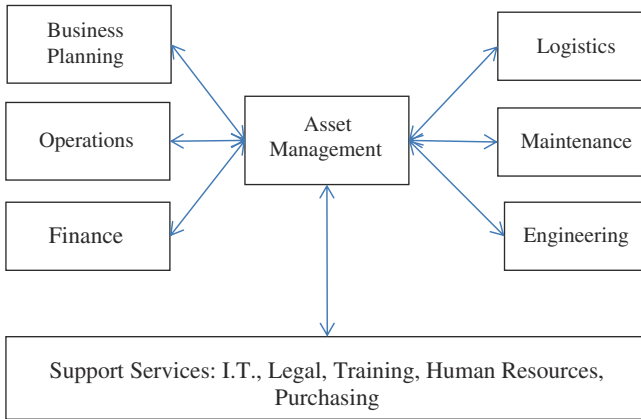

Fig. 3.1 Asset management—a matrix activity

with personnel in other business areas. Important characteristics of good asset managers are a willingness to learn the thought processes of other areas such as finance, information technology and human resource management, and skills in communication, conflict resolution, and dealing with differing cultures and with varying planning horizons. However, operations, finance, engineering design, and the building or installation of plant and equipment are generally not part of the asset management role. The normal running of maintenance and logistics operations are also not part of the asset management role, although responsibility for these departments may come under a Chief Asset Manager.

3.1.1 Understanding Needs and Expectations of Stakeholders

A *stakeholder*¹ is someone with an interest in something. If you have bacon and eggs for breakfast, the chicken is a stakeholder but the pig is committed. In an organization, internal stakeholders are the employees and functional groups such as those indicated in Fig. 3.1. Shareholders and owners are also stakeholders. In the public arena taxpayers are stakeholders, although their influence is indirect. External stakeholders include customers, users, suppliers, contractors, and regulatory authorities.²

¹ ISO 55000 Clause 3.1.22 gives a definition.

² ISO 55001/2 Clause 4.2 gives more detail of stakeholders.

3.1.2 *Understanding the Organization and Its Context*

Asset managers require broad knowledge of the external and internal working context of the organization.³

3.2 Competence

Competence is the ability to apply knowledge and skills to achieve intended results.⁴ The asset management system should specify competency requirements for personnel involved in asset management.^{5,6} The competency requirements will impact on the recruitment, training, and promotion of persons in the asset management field.

Asset management needs competencies⁷ suited to the requirements for knowledge, skills, experience, behavior, attitudes, and attributes related to asset management. The range of required knowledge will involve an understanding of technical areas of the business, the commercial needs of the business, the relevant suite of asset management techniques, skills in bringing together plans and projects, and in presenting a balanced view of all aspects of an issue as a basis for business case development and decision making. The ability to work in a team and to share, mold, and integrate opinions with logic and objective data are important.

Members of asset management groups will generally be drawn from technical, operational, and service areas and will be people with substantial experience and competence in their earlier roles. Members in specialist roles such as finance, legal, and engineering will combine their specialist knowledge with a thorough grounding in the technical and operational environment of the organization.

Asset managers will be selected for their combination of equipment knowledge and awareness of business requirements and processes. Equipment knowledge will assist them in identifying developments in their technical field, and assessing their practicality and business value. It is important to recognize and to provide sound responses to both customer pull and technology push.

³ ISO 55001/2 Clause 4.1.2.

⁴ ISO 55000 Clause 3.1.3.

⁵ *Competency Requirements for the management of physical assets and infrastructure*. The Institute of Asset Management. www.iam-uk.org.

⁶ ISO 55000 at Clause 2.5.3.5.

⁷ ISO 55001 Clause 7.2 Competence: “The organization shall determine the necessary competence... ensure...persons are competent...”.

3.3 Required Areas of Competence

Areas of competence required in an asset management group are as follows:

- Business awareness
- Demand forecasting
- Asset requirements planning
- Financial analysis
- Business case development
- General technical knowledge
- Technical knowledge of the specific industry
- Awareness of developments in the relevant asset types
- Acquisitions management
- Life cycle planning
- Logistics
- Risk management
- Change management
- Configuration management
- Reliability analysis
- Maintenance management
- Project management
- Communication
- Negotiation
- Team work
- Personnel development.

Figure 3.2 shows in graphical form the overlapping areas of competence needed by personnel in the asset management field.

3.3.1 *Filling the Gaps*

Guidelines for the development of an asset management-related competency management system are given in ISO 55002 at Clause 7.2.⁸ Unlike many other areas of business, there is not an obvious direct educational feed-in to the asset management area. Entrants to asset management cannot normally be expected to have strong competencies across all areas at the outset, and training and education are required to assist development over a period.

The most common route is for asset managers to be recruited from persons with the basic technical knowledge of the industry, either from an engineering or maintenance source. The need for people skills, means that those who naturally are good communicators will be likely to succeed as asset managers.

⁸ ISO 55002 at Clause 7.2.

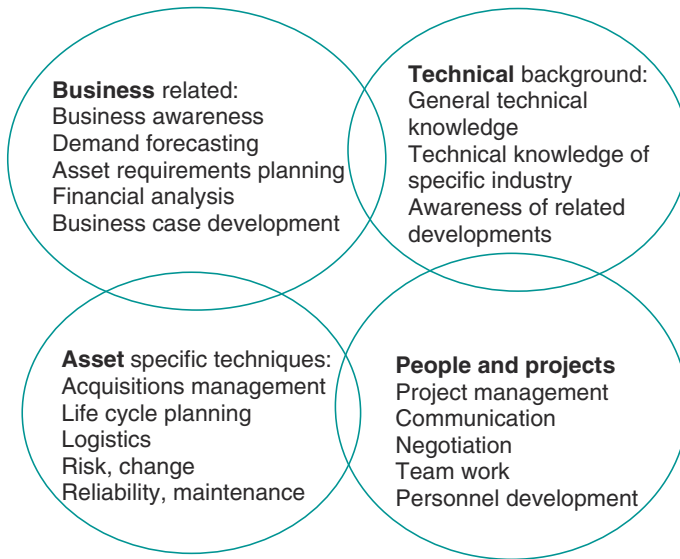

Fig. 3.2 Areas of competence in asset management

This then means that education and training are required in the areas of business finance, in business case development and budgeting, and in asset management specific techniques such as acquisition project development, change management, life cycle asset planning, logistics of asset support and in risk, contingency, reliability, and maintenance systems.

3.4 Key Activities Where Competence Is Needed

Specific tasks where particular competence is needed include the following:

- Development of asset management plans and interface with business plans
- Business case development for improvements and problem solving
- Preparing CAPEX and OPEX proposals—avoiding the asset death spiral
- Management of acquisitions and related change
- Stakeholder liaison
- Managing the maintenance interface, including resource provision, asset condition assessment, and repair/replace decisions
- Reliability and root cause analysis
- Risk identification and mitigation/contingency planning
- Supplier relationships.

3.5 Roles, Responsibilities and Authorities⁹

The following are key personnel roles in asset management. The assignment of persons to these roles will depend on the size and structure of the organization, and the existence of a role does not necessarily imply that that role constitutes a full time job.

Chief Asset Manager

The Chief Asset Manager plays a key role in asset-related decisions and activities. This includes:

- Participation in business development planning to ensure that the asset implications of the organization's business objectives and plans are understood by senior management and that the corresponding asset requirements are incorporated into all business plans.
- Developing plans and financial proposals for asset-related capital and operating expenditure, both for new assets and for the sustainment of existing assets.
- Taking responsibility for the many activities that assets require in an asset intensive organization—as represented in the Strategic Asset Management Plan (SAMP).

This role requires a combination of technical, financial, and personal communication abilities.

Asset Manager

Below the level of the Chief Asset Manager there will be asset managers involved with particular ranges of assets. For example, in an electricity transmission organization there are asset managers for Switchgear, Transformers, and Secondary Systems within the substation asset group. Asset Managers require knowledge of relevant technologies and their operational context. They provide management and leadership for the group, and also provide input into business development in relation to their technical area. This includes replacement planning, budgeting, and analysis related to equipment utilization, reliability, maintenance, and support policy.

Asset managers are likely to come from engineering or logistic backgrounds, but they need to be familiar with the business in its broader context, and with general accounting and financial concepts. While the ultimate detail of accounting and finance will remain the province of specialists in those areas, most business decisions are based on estimates or forecasts made from the basis of combined technical and business knowledge. Here, asset managers have a key role to play in providing timely and sound input into business decisions. A company with a

⁹ ISO 55001 Clause 7. Support, 7.1 Resources: “The organization shall determine and provide the resources needed for... the asset management system.”

strong asset management presence is likely to outperform one where asset management is weak or nonexistent, and it is particularly important that asset managers can provide a working link between the technical and the financial elements of the organization.

Project Manager

Project Managers—Acquisitions

Project managers—Sustainment

Acquisition and development projects constitute a major activity of the asset management function.

Project managers are typically trained and certified in relation to the requirements of professional organizations such as the Project Management Institute and the Project Management Body of Knowledge (PMBOK).

Finance, accounting and costing

Personnel in these fields play an important role in assessing costs, assessing the financial viability of projects, and in managing the finances of projects in progress.

Engineers

Engineers are required to provide detailed technical knowledge essential to decisions relating to the organization's assets. This includes knowledge of design and operation, and engineering and data analysis skills in reliability, maintenance, and through life support and replacement decisions. Engineers may take "subject matter expert" roles which run across an organization. For example, an expert on draglines may advise on technical and asset-related decisions across a range of sites.

Logisticians

Asset management is a mainstream area for the logistics specialist. The work involves applying such techniques as logistic support analysis and level of repair analysis. This activity area extends into configuration management, cataloging of spares, identification and coding of maintainable items of equipment, setting inventory control parameters, and ensuring that the distribution system for assets, consumables, and spare parts is appropriate to needs. A mining company once purchased a vehicle to work underground but then found that it was too big to be taken down the shaft. Roles are summarized in Fig. 3.3.

Technical Support Specialists

Lawyers Contracting and contract managers.

Procurement managers and officers

General staff are also required covering clerical and administrative functions.

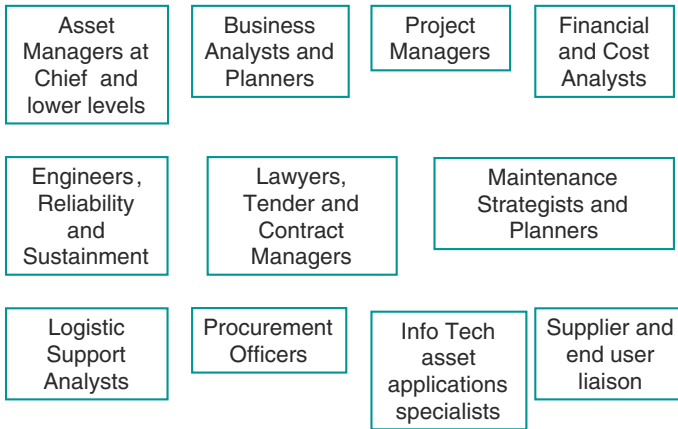

Fig. 3.3 Personnel roles in asset management

3.6 Engineering and Maintenance Roles

3.6.1 *Engineering Leaders*

Engineering Leaders may be Project Engineers, Engineering Managers, or Project Managers. It is the responsibility of the Engineering Leader to ensure that technical provisions are implemented and complied with. Engineering leaders have a responsibility to approve the appointment of Technical Authorities.

3.6.2 *Technical Authorities*

A person in a position of technical authority is required to ensure the technical integrity of assets by:

- Participating in the development, monitoring, and review of asset management plans.
- Reviewing inspection reports, failure reports, and technical data and making follow-up reports and recommendations.
- Providing technical support and recommendations to other personnel as necessary.

3.6.3 *Maintenance Manager*

Responsible for the overall activities and performance of the maintenance department. Budgeting and budgetary control.

3.6.4 Maintenance Superintendent

In a large organization, there may be maintenance superintendents for various areas and also for various trades, e.g., mechanical, electrical. It is the responsibility of the Maintenance Superintendent to:

- Direct, manage, and review maintenance activities including facility shutdowns and turnarounds.
- Manage and direct suppliers contracted to engage in maintenance activities.

3.6.5 Maintenance Team Leader

It is the responsibility of the Maintenance Team Leader to ensure that:

- Maintenance activities are supervised, controlled, and carried out in accordance with the maintenance policies, systems, plans, procedures, and work schedules as determined by management.
- All such activities are performed to the required work standard.

3.6.6 Maintenance Planner

It is the responsibility of the Maintenance Planner to:

- Produce planned maintenance programs, shutdown/turnaround and long term, work scopes, and associated documentation to the required work standard.
- Provide ongoing planning support to the Maintenance Schedulers and Team Leaders.
- Initiate, review, and update maintenance plans and documentation as appropriate.

3.6.7 Maintenance Scheduler

It is the responsibility of the Maintenance Scheduler to:

- Produce and deliver regular and timely maintenance work schedules in liaison with operations personnel.
- Produce supporting documentation and in conjunction with the maintenance supervisor, assign suitable resources that will enable such activities to be carried out to the required work standard.

3.6.8 Document Controller

It is the responsibility of the Document Controller to ensure that all related documents are controlled, are correctly filed, and readily accessible for reference, research, review, or audit purposes.

3.7 Personnel Development System

A competency development and recording system¹⁰ is needed in order to manage the competency of personnel. Topics to be covered include the following:

- Identification of required competencies.
- Development or identification of training and educational courses.
- Delivery of the required training and educational programs.
- Competency assessment.
- Documentation of training received and competency achieved.
- Personal development programs.
- Succession planning.
- Hiring of competent people.
- Evaluation and feedback in competency assessment.
- Linking of the asset management competency program with general personnel training and development processes.
- Linking of asset management system roles with business/financial/planning roles and people.

The competency of contractors and outsources must also be addressed.

3.8 Competency Assessment

Competency assessment is based upon:

- Qualifications;
- Demonstrated understanding; and
- Demonstrated experience;

Getting the right people into the right positions in asset management involves recognizing the competencies that are needed and recruiting, selecting, and developing people to deliver these competencies. For any particular appointment it is useful to identify the main competencies needed and then assess individuals against this. A simple rating system for any competency is:

¹⁰ ISO 55002 Clause 7.2.

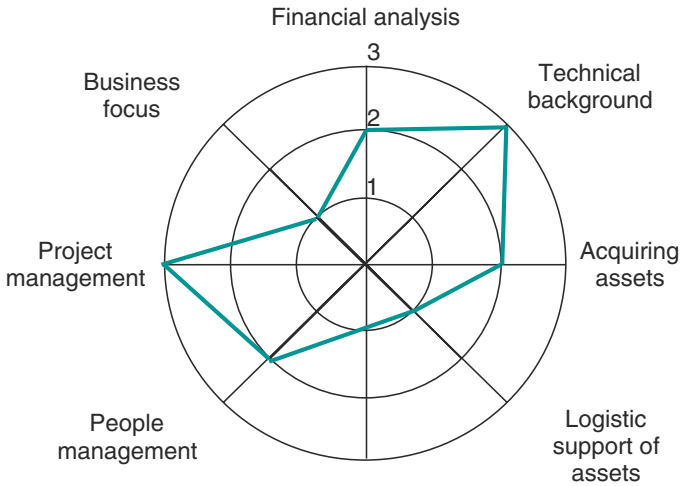

Fig. 3.4 Spider diagram for competency analysis

- 0 = None,
- 1 = Low,
- 2 = Medium,
- 3 = High.

A spider diagram helps in visualizing and presenting the competencies required for a particular post, and the competency status which has been assessed for a particular candidate. This approach is illustrated in Fig. 3.4 which is a spider diagram relating to the position of Asset Manager. This can assist with decisions on appointments, and also identify where individuals would benefit from additional training and experience.

Grander terms for the level of competency are: 1 = Foundation, 2 = Professional, and 3 = Mastery.

3.9 Leadership¹¹

Leadership is an important factor in effective asset management. The asset management function must be represented at a sufficiently senior level in the organization if adequate leadership in the asset management field is to be achieved. Without this leadership, business plans can fail due to inadequate or inappropriate asset provision or support. The existence of a Chief Asset Manager, or equivalent representation at Chief or Vice-President level, is important in this regard.

¹¹ ISO 55001 Clause 5.1 ‘Leadership and commitment’: “Top management shall demonstrate leadership and commitment to the asset management system.”

A primary element in leadership in asset management is the ability to combine an understanding of the business objectives with an understanding of the role of physical assets in meeting those objectives. This is the starting point for ensuring that the business objectives and the asset management plans are aligned. This must then be followed up by appropriate asset provision, asset support, and resources for the sustainment of an effective asset management system.

Leadership also plays a key role in establishing a positive workplace culture. This means extending from a sound practical system of asset provision and support, into encouraging active participation of all levels of staff in establishing a culture which respects safety, reliability, and cost effective operation.¹²

More generally, though, leadership is not necessarily the same as good direction, so do not get led astray.

3.9.1 Communication and Response¹³

Ongoing systems should be established for communication between management, employees, customers, suppliers, and stakeholders in regard to asset management issues and developments. In this way, asset knowledge will be developed, disseminated, and retained.

Communication must be two-way. It is highly important that good communications are established with employees in regard to feedback from operating and maintenance levels, as this is where the first indications of asset-related problems often come to light. Problems must not be swept under the carpet due to laziness or fear of retribution. Staff should be given time and encouragement to refer problems upward so that they may be acted upon. This includes respect for minority opinions and giving priority to bad news. If senior staff are ignorant of, or choose to ignore significant problems, respect will be lost and the workplace culture will deteriorate.

One day I saw a loose nut lying on the floor of my garage. No one else was going to do anything about it, so I checked to see where it had come from. I found that it was from the motor that drove the automatic door and that the motor was loose on its bearers. I replaced the nut and checked and tightened the other ones. In a working situation I might have ignored the nut, or even kicked it under a pile of wood—a reaction known jokingly as “industrial blindness,” which occurs where actual and potential failings are routinely ignored because no one seems to care.

Specific techniques which form a basis for good communication about assets are Failure Recording and Corrective Action Systems (FRACAS) and the use of regular tool box meetings involving operations and maintenance staff and

¹² J.R. Laffraia and J. Hardwick, *Living Asset Management*. ISBN 978 1 922107 25 1.

¹³ ISO 55001/2 Clause 7.4 Communication: “The organization shall determine the need for... communications ...what...when...with whom...how.”

supervisors. It is important that feedback from the workplace penetrates to higher levels of management where there is sufficient financial authority to address problems. Managers should understand the effect on business operations of shortcomings in asset performance and condition. It is important that any adverse findings are acted upon and not merely shelved.

The film, “The Caine Mutiny” dramatizes the difference between two ships’ captains. The first had good communication and rapport with his crew. He took note of suggestions and delivered a positive response or explanation. As a result the crew responded with good performance. His successor was a martinet whose reaction was to punish mistakes or delays, but not to listen to reasons why. The eventual result was a mutiny when conditions became tough.

3.10 Exercises

3.10.1 Self-Assessment Quiz 3.1

1. Identify four areas of an organization with which asset management has major interfaces.
2. What is the definition of competence?
3. Identify six asset management activities where competence is needed.
4. Identify six personnel roles in, or closely related to, asset management.
5. Identify six points to be covered in a system for the development of asset management personnel.
6. Why is leadership in asset management important in assisting an organization to meet its business aims?
7. Why are good communications between asset management and operations and maintenance important?

3.10.2 Pacific Earth Moving Part 1

Pacific Earth Moving is a medium sized company which sells, maintains, and hires out excavators, bulldozers, graders, trucks, and other earth moving equipment. Increased demand for the company’s services has led to the approval of a proposal to implement a major expansion plan. Several senior managers who grew up with the business have recently retired and a new organizational approach is needed to implement developments.

You have been assigned to advise Pacific Earth Moving on establishing an organizational structure for asset acquisition and asset management for the future, and indicating what personnel should be recruited. Provide an outline of the proposed organization in the form of an organization chart and an indication of the personnel roles and competencies required by the company.

3.10.3 Self-Assessment Quiz 3.1 Solution

1. *Identify four areas of an organization with which asset management has major interfaces.*
Any four of Business planning, Operations, Finance, Logistics, Maintenance, Engineering.
2. *What is the definition of competence?*
Competence is the ability to apply knowledge and skills to achieve intended results.
3. *Identify six asset management activities where competence is needed.*
Any of the areas shown in the dot points of Sect. 3.4.
4. *Identify six personnel roles in, or closely related to, asset management.* Any of the dot points shown in Sects. 3.5 and 3.6.
5. *Identify six points to be covered in a system for the development of asset management personnel.*
Any six of the dot points shown in Sect. 3.7.
6. *Why is leadership in asset management important in assisting an organization to meet its business aims?*
Without this leadership, business plans can fail due to inadequate or inappropriate asset provision or support.
7. *Why are good communications between asset management and operations and maintenance important?*
Because feedback from operations and maintenance gives the first indications of asset-related problems.

3.10.4 Pacific Earth Moving Part 1

The answer to this exercise is based on Sect. 2.5 of Chap. 2 and Sects. 3.3–3.5 of this chapter.

3.11 Asset Management—Who Needs It?

Every few weeks Jock would call in on his Pop at his old weatherboard house near the Yarra river at Warrandyte. Pop barracked for Richmond, unlike Jock who was a Brisbane Lions supporter. Pop also went along to the local oval every week to watch his youngest great-grandchild play for the Warrandyte Bloods in the local under 12 s league. After the usual football banter, Jock told Pop about his new job.

“What do you mean asset management?” asked Pop. Jock explained.

“We could have done with some of that in the early days of the war,” said Pop. Jock liked to hear Pop’s stories and waited for him to go on.

“Norway was a disaster,” said Pop. “We were supposed to block the German advance but we were landed without any of our stuff. We were sitting on a hillside with just our packs and rifles when an officer told us to start digging in. He didn’t stick around so we just took a couple of casual kicks at the rocks and sat down again.

Then my mate Happy Kershaw noticed a plane in the distance, and said that it was coming our way. Happy stood up and said, ‘It’s dropping something.’

We watched idly as the something fell to the ground, and then jumped a mile as it gave an almighty bang. Realization dawned, as the plane veered away and we could see black crosses on its wings. After that we lay flat, and dug furiously with our bayonets and bare hands.

Later that night we were pulled back and shipped out on a destroyer, but all our gear was lost. Someone must have learnt a lot about logistics from that little episode,” said Pop.

Part II
Acquisition and Development of Assets

Chapter 4

From Concept to Project Approval

Ideas are two a penny.
Bill Gates

Abstract The aim of this chapter is to describe the asset development process from concept to project approval. This chapter shows how asset management works with other parts of the organization in order to create sound development plans. The focus is on procedures for larger scale developments, such as major acquisitions. The chapter starts at the concept level, goes through the preliminary approval stage, to feasibility planning and on to final project approval. *Outcomes* After reading this chapter you will know about:

- The stages involved in asset development;
- The structure and role of development planning teams;
- The concept of capability, with examples;
- The identification of business needs;
- The concept of capability gap analysis, the development of a capability requirements statement and an operational concept;
- Prefeasibility analysis of development options, leading to a proposal at the preliminary approval stage;
- Feasibility analysis and the creation of an acquisition or development plan.

4.1 Project Initiation

Business development generally involves a senior level group which identifies business development needs and examines options for meeting those needs. This involves establishing priorities, assessing financial returns, assessing sources of funding and possible constraints. If an option appears favorable, the development

group will initiate a major development project. The rationale behind asset intensive projects may be one or more of the following:

- a. Capacity creation, expansion, reduction, or consolidation
- b. Process cost reduction
- c. New or improved business opportunities or directions
- d. Renewal or updating of existing capacity
- e. Process improvement in yield or quality
- f. De-bottlenecking
- g. Protection of assets
- h. Technical developments, internally and externally
- i. Environmental or safety improvements
- j. Response to regulatory changes.

Development ideas may have a *top-down* or a *bottom-up* origin. A top-down development will originate with senior management. A bottom-up development will start in the operations areas rising through the hierarchy and then feeding into the business development process. The organization should encourage business development from the bottom-up as well as from the top-down. Workplace personnel and managers close to the workforce are in an excellent position to see how improvements can be made, often on a very cost-effective basis. They should be encouraged to develop and bring forward proposals in a spirit of *continuous improvement*.¹

For a concept to proceed into the mainstream of development planning, the backing of senior management must be achieved. A *project initiation budget* needs to be set aside, and procedures established, for the purpose of getting ideas to “square one” of the development process.

4.2 Types of Acquisition or Development

Several different types of asset acquisition or development processes can be identified as follows:

- a. Off-the-shelf acquisition
- b. Business development but not primarily acquisition
- c. Design incorporating selection of off-the-shelf items
- d. Design from the drawing board but standard technology
- e. Introduction of technical change
- f. Design with developmental technology
- g. Research and development.

An off-the-shelf acquisition is one where we acquire an existing product, with no design or modification involved. With off-the-shelf acquisitions the logistic

¹ ISO 55002 Clause 10.3.

support requirements should be readily met and often are available as a standard part of the acquisition package. As we proceed down the above list, the level of complexity increases and so does the risk in the project. Businesses should be wary of projects that involve significant amounts of development work as they often lead to technical problems and delays. In such cases it is best to undertake a pilot project initially to eliminate as many unknown factors as possible.

4.3 Business Development Planning

Business development is a key role of senior management. Development planning requires confidentiality, as plans are discussed which may influence the overall direction of the business, but which are still in a state of flux. A *business development group* is normally established to generate, assess, and monitor major potential developments. In looking to the future, the business development group will need to draw on specific asset knowledge and in this situation the existence of a recognized asset management group with the necessary knowledge and skills is an advantage.

4.3.1 Major Projects

An example of a major strategic development decision is a commitment to develop a new mine. For example, a mining company may be considering developing a mine which will produce particular mineral, say nickel. A decision as to whether to proceed with the development of the mine will depend on an assessment of the current and future demand for and forecast price of nickel, the development cost of the mine, the production cost per tonne, the likely yield and other factors such as transport costs, energy costs, and regulatory issues.

Once a concept takes on the aspect of a major project, which usually means exceeding some financial threshold of the order of tens of millions of dollars, a development planning team will be formed. The asset management group, or equivalent, will play a key role here, particularly in regard to the asset acquisition and sustainment aspects of the project.

The stages of development of a major project are as follows:

- Project initiation
- Capability requirements analysis
- Prefeasibility analysis—identify options
- Feasibility analysis—detailed plan
- Project approval
- Implementation.

Figure 4.14 Steps in the Asset Management Process, provides more detail of the steps involved in a major asset development project, and the subsequent sustainment of the asset in-service.

4.3.2 Minor Projects

Minor projects play an important role in supporting and developing business performance. These developments may be handled within operating divisions and often form part of existing job activities rather than giving rise to specially formed teams. The logic of the steps involved in appraisal and implementation is much the same in both major and minor cases, but the volume of work is less in a simple acquisition or a development with modest logistic support needs.

4.3.3 Developmental Flexibility

In this chapter we describe processes for the assessment of business needs and the determination of asset requirements. In practice, our processes must not delay acquisition or development unnecessarily. Where the business justification is clear and the needs can be met by well-recognized steps, then our organization should be such that we can proceed without delay.

In a warehousing operation, for example, if additional forklift capacity of a standard type is needed, a rapid and favorable assessment of the factors involved should result in the acquisition of an additional machine within days. On the other hand, the development of a new warehouse site would involve a detailed analysis of issues such as future demand, site availability, site access, materials handling, and personnel requirements for operations and support. The extent of our deliberations, in terms of detail and time, should reflect the level of complexity and degree of urgency of the business need, and the acquisition or development process should adapt accordingly.

4.3.4 Delegation of Financial Authority

The organization should encourage business development from the bottom-up as well as from the top-down. Workplace personnel and managers close to the work-face are in an excellent position to see how improvements can be made, often on a very cost-effective basis. To take advantage of this there should be delegation of financial authority to intermediate and lower management levels. In addition, it is desirable to provide a budget for unforeseen events or contingencies.

Minor projects can form a basis for addressing problems or initiating development ideas which are then evaluated. The results will form a basis for expanding on or alternatively abandoning an idea. Adequate local financial discretion will tend to avoid the asset death spiral. An example of guidelines for financial delegation within a company is shown in Table 4.1. The “Unforeseen” category is a contingency budget enabling managers to react quickly to unforeseen events.

Table 4.1 Financial delegation example

Project type	Value range	Approval level	Management level
Small	\$0–10,000	Local	Local
Minor	\$10,000–100,000	Division	Local
Medium	\$100,000–2,000,000	Business	Division
Major	\$2,000,000+	Business	Business
Unforseen	To \$100,000	Division	Division

4.4 Capability

An important concept in business development planning and in asset management generally is *capability*. Capability is the ability of a system to meet a specified need in all its aspects. That is, it covers the combined concepts of capacity and ability, including all the assets and associated personnel, resources and services which are required to meet the need. It is essential that those involved in business development planning understand the concept of capability, as otherwise they will not take a sufficiently comprehensive view of all aspects of a development.

To illustrate the meaning of “capability” consider the example of a fire station. The primary assets are the fire engine or engines and the building which houses them. However, the total capability required, goes beyond these primary assets. There is a need for provision and storage of a range of firefighting and fire protection equipment, basic medical equipment and supplies, control and communications equipment, office space and equipment, electricity and water supplies, transport access roads and parking space, short term food supplies, the provision of training rooms and training facilities, the availability of personnel to staff the facility, and planning, and training for operations and maintenance. These elements in total comprise the firefighting capability which is needed. Figure 4.1 summarizes

Fig. 4.1 Capability example—fire station

Prime equipment = Fire Engines and Building
 Capability includes:
 Water supply
 Crew accommodation
 Office and control room
 Equipment storage
 Chemicals storage
 Training facilities
 Communications equipment
 Navigation equipment
 First aid equipment
 Vehicle access and parking
 Integrated Logistic Support (ILS) items
 Through Life Support (TLS) arrangements
 Risks e.g. Delivery delay, communications compatibility.

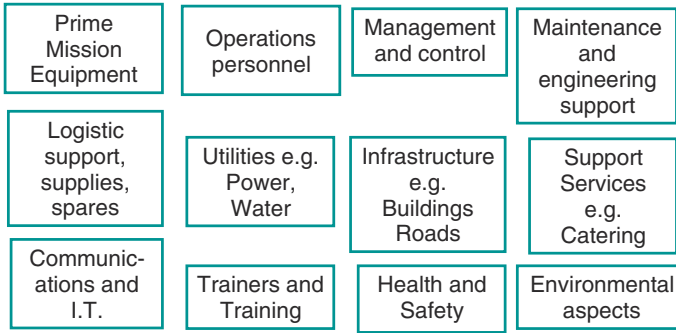

Fig. 4.2 Inputs to capability in the general case

this. In addition to the basic list of items, technical specifications will also be needed, such as the quantity, capacity, or level of service. The key point here is to be aware of the extensive range of items which typically constitute a capability.

Figure 4.2 illustrates the types of inputs to asset capability in a general case.

4.5 Capability Requirements Planning

Capability Requirements Planning is the determination of the capability requirements needed in order to support a planned business activity over a planning horizon. Figure 4.3 indicates the steps in capability requirements planning.

Capability requirements planning starts with *demand analysis*, that is, an assessment of the demand for a product or service, originating from the customers,

Fig. 4.3 Capability requirements planning

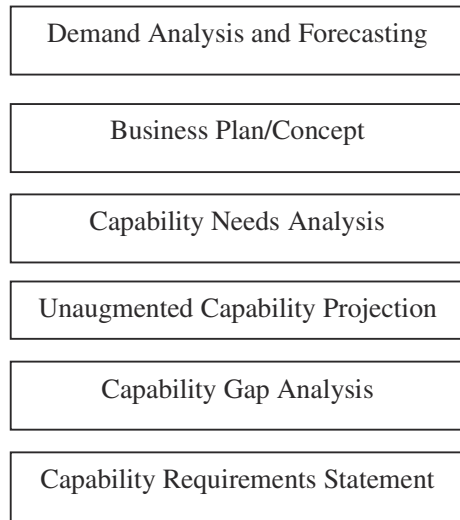

users, or stakeholders. Based on this demand, a business plan is developed. We then proceed into a *needs analysis*. A *needs analysis* is an assessment of the total capability required to support the business plan. An example is where the growth or reduction in demand for electricity, leads to a plan to expand or reduce the supply. This leads to an estimate of the generating capacity, transmission capacity (i.e., high voltage lines), and distribution capacity (i.e., local supply lines) needed at various geographical points over the planning horizon.

The next step is a projection of the *un-augmented asset capability*. This is the available capability, projected over the planning horizon, if no new development is undertaken. To assess this we start from the existing capability and project forward, taking into account all factors which will deplete this capability, such as the retirement of old plant, the impact of technical and regulatory changes and also any augmentation from the coming to fruition of existing committed plans. In this step we do not consider the addition of new capability which has not yet been approved. The result will be a projected available level of generating, transmission, and distribution capacity going forward in time.

The next step is *capability gap analysis*, where we identify the gap between the required capability and the projected un-augmented capability. This analysis will indicate a capability gap moving forward in time. In the electricity generating case the gap will be in megawatts of generating capacity and may also reflect legislation on the source of energy.

From the capability gap analysis we construct a *capability requirements statement*, which is a statement of the capability which we need to acquire to fill the gap. This statement will address both the quantity and type of capability required, the timings required, and issues such as level of service, essential criteria, and desirable criteria.

The capability requirements statement will form the starting point for the creation of a development plan which will deliver the capability necessary to support the business plan.

4.5.1 Development Planning Teams

The senior management of the organization will exercise a review function which will include an initial assessment of major development proposals. When a major proposal is seen as having potential it will become part of the *Requirements Portfolio* of projects and a development planning team will be formed. A development planning team is a group of people whose job is to plan the development.

Development planning teams will appear in the organizational chart as shown in Fig. 4.4 and will report to a development manager. They will draw on personnel from the Business Development Group, on the user area most involved in the development, and on asset management personnel with skills in the development area. Key stakeholders will be identified and brought in as required. The team will

Fig. 4.4 Development planning teams in the organizational structure

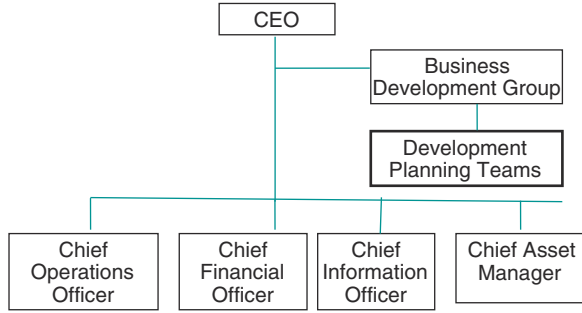
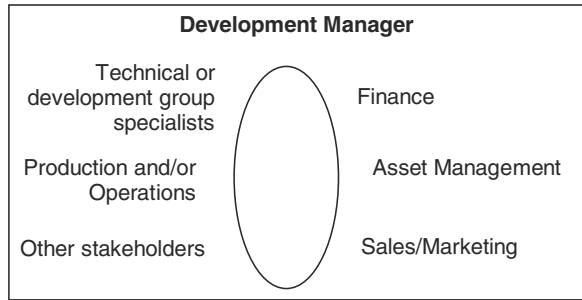

Fig. 4.5 Sources of development team representation



report to the head of business development, and through him, to the board of the company.

For large projects, subsidiary working groups may be established to deal with specific issues. If necessary, a separate exploratory or trials stage will be established. It is better to put in the effort at the early stages of a development than to rush into a project which later turns out to be technically or financially unsound, though in any case there is always an element of risk remaining.

Some asset-based businesses involve a continual succession of projects, such as small- or medium-sized building or equipment renewal projects, and they will be organized to deal with this routinely. The organization of each project will depend on its size and complexity. For smaller projects, the development will take place within the relevant operational area.

Figure 4.5 illustrates sources of development team representation.

4.5.2 Demand Analysis and Forecasting

“If you can look into the seeds of time
And say which grain will grow and which will not,
Speak then to me.”
Shakespeare, Macbeth

An underlying factor in development planning is forecasting future demand for the product or service. Forecasting is a general business challenge, but current asset knowledge and related technical knowledge make asset managers important contributors to the forecasting process. The simplest cases involve an extrapolation of current demand, for example, increasing demand for infrastructure and services in areas of urban growth. Harder to predict are the effects and speed of technological change and the actions of governments which can radically and unpredictably intervene in markets and influence the pattern of demand.

In the forecasting process we consider the following aspects for a given product or service:

- Level. What is the existing level of demand?
- Trend existing. Is the level of demand currently rising, falling, or remaining steady?
- Trend forecast. Are there market or technological factors that can affect trend in the planning period, and if so, in what direction?
- Seasonality. Are there seasonal or other cyclic factors that affect demand?
- One-Offs. Are there one-off or rare events which need to be allowed for?
- Outliers. These are past events which may need to be considered separately, for example, a flood, storm, or fire which may or may not recur.

However good the forecast, unforeseen changes can occur. For this reason, an important consideration is flexibility. Asset options which facilitate flexible responses to change are often better than longer term fixed commitments.

4.5.3 Demand Management

Demand management is the use of techniques which influence the demand for a product or service, in contrast to planning to meet the “unmanaged” demand. An example is to have a suitable pricing policy. The provision of a nominally free or heavily subsidized service of some type, such as public transport, can result in excessive levels of demand on the one hand, or in the provision of services that few people use. A guideline is to avoid subsidies, as the fact that there is no such thing as a free lunch will then combine with Adam Smith’s invisible hands to produce a manageable and sustainable result. Sure thing!

4.5.4 Needs Analysis

Needs analysis is the identification of what the organization needs in terms of asset capability in order to support its business plans. Initially, needs analysis works at the level of prime equipment and takes a broad view of business development. Any actual development requires a more detailed consideration of the factors involved in achieving and delivering a capability.

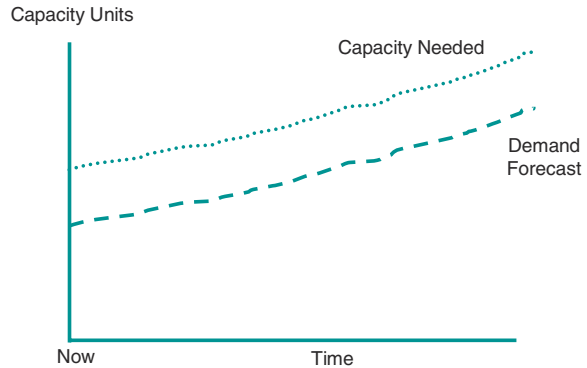
Fig. 4.6 Needs analysis

Needs analysis looks at several time frames on a rolling basis, such as 0–5 years, 5–10 years, 10–20 years. Analysts consider likely scenarios and responses to those scenarios, and identify the capability needs of the organization over the corresponding periods. This requires a good understanding of how business functional requirements convert into asset capability requirements.

Given a demand forecast, Fig. 4.6 schematically illustrates the principles of needs analysis at a simple level. The dashed line shows a projected increase in demand for a product or service. The dotted line shows the projected level of capacity needed in order to meet the demand, allowing for some spare capacity to accommodate variability and risk.

4.5.5 *Un-augmented Capability Analysis*

The next step in capability requirements planning is to assess what the capability will be over the planning horizon if no augmentation is carried out. We estimate the decrease in our production or service capacity if no acquisitions are made. Primarily, this decrease will be due to older equipment being retired or becoming obsolete. In Fig. 4.7 the light solid line, labeled “Capacity if no Acquisitions” shows the projection of the un-augmented capacity.

4.5.5.1 **Remaining Life and Retirement Schedule**

In assessing the un-augmented capability we consider the retirement of existing assets as they age. For capability requirements planning purposes we also need to consider the lead time required in order to replace them, whether as a direct replacement or as part of an alternative solution. Planning decisions must be made in sufficient time to allow for the lead time activities of the acquisition process.

Fig. 4.7 Capacity gap

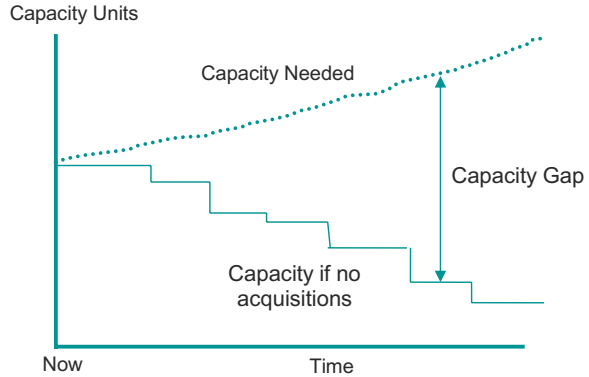

Details of this type of planning process is considered in Chap. 7—Asset Continuity Planning. At this stage we need to be aware that a retirement schedule has to be created for existing assets and that this will provide input into the “un-augmented capability” part of the needs analysis.

4.5.6 Capability Gap

The capability gap is the gap, projected forward over the planning horizon, between:

- a. The capability that we need.
- b. The un-augmented capability.

The gap may be positive or negative, that is to say, there may be a shortage of capability or an oversupply. The gap is the driver for new capability or, in the case of excess, for the disposal or reallocation of resources.

Figure 4.7 illustrates the capability gap, but for simplicity it is shown only as a single, or prime equipment, capacity level. The light solid line, labeled “Capacity if no Acquisitions” shows the projection of the un-augmented capacity. The gap between the capacity needed and the un-augmented capacity is the capacity gap. We may also refer to this gap as the *preplan capacity gap*, since it represents the situation before any plans to fill the gap are introduced. In practice we would consider a prime equipment capacity gap initially and then follow up with a consideration of the related subsidiary items of the capability. The gap will vary through time, in this case increasing as demand rises and un-augmented capacity falls. It is important to project the gap forward on the basis of the un-augmented capability, otherwise a lack of appreciation of the variations in the gap over the planning horizon can lead to the development of inferior capability plans. In some instances the gap may rise and then fall, suggesting that the company should plan to cope with a temporary rise which is quite different to dealing with a permanent one.

4.5.7 Capability Requirements Statement

Having completed the capability gap analysis, the development team prepares a *capability requirements statement*. This statement identifies the capabilities which are required to fill the capability gaps. The capability requirements statement forms a basis for further analysis and refinement toward a development plan. The statement must provide sufficient information to act as a starting point for subsequent development analysis, and take account of the financial aspects of the decisions, but great precision is not expected at this stage.

For example, a capability requirements statement may specify that a company will require trucks with sufficient capacity to move a specified volume of goods over specified routes, and logistic support for those trucks. The statement will also specify factors of timing and cost based on stated market expectations. The capability requirements statement will also specify *decision criteria* that any feasible plan should meet. Some of the criteria will be deemed to be essential, such as the ability to move a given volume of goods, and the ability to meet certain design regulations, whereas other may be desirable, for example, a requirement relating to fuel consumption.

4.6 Value Engineering

Value engineering is a systematic process of reviewing any acquisition proposal to see how it might be achieved in a cost-effective manner. It can be applied to the capability defined in the Capability Requirements Statement, or at other stages of an acquisition process. It involves asking a series of questions which in practice often lead to cost reductions, logistic support savings, or design improvements. At the same time we must avoid a “penny wise, pound foolish” approach, which may make short-term savings but cause longer term expense, and compromise the aims of the development.

Figure 4.8 provides a checklist of questions typical of value engineering.

Questions	Comments
Can the function or equipment be eliminated	
Can the function be achieved in another way	
Is there a cheaper alternative	
Are all the features of the equipment required	
Is the capacity greater than necessary	
Can cheaper materials be used	
Can parts be standardized	
Are the finishes specified essential	
Can installation time be reduced by design changes	
Can energy consumption be reduced	
Can maintenance costs be reduced	

Fig. 4.8 Value engineering checklist

4.6.1 Value for Money

A related concept is the need to provide value for money, that is, not to spend money unnecessarily on items or features that are not essential. This may be obvious to the person who provides the money, but needs to be emphasized in situations where the purchaser is remote from the funder, for example, in public sector purchases.

4.7 Creating the Development Plan²

Management will review the capability requirements statement and decide if the project is to go forward. If so, the project will move out of the requirements portfolio and go into the *planning portfolio*. The capability requirements statement is the starting point for the creation of plans to fill the capability gap. In the case of a major development, these plans are developed in two stages, referred to as Prefeasibility Analysis and Feasibility Analysis. If the project proceeds successfully through these stages, this leads on to the acquisition and implementation of the capability. Figure 4.9 shows the steps at the prefeasibility and feasibility analysis stages. In practice the level of formality in moving through the planning process will depend on the complexity or otherwise of the project and the timing requirements of the development. However, the basic logic of the process is valid, even when some steps are accelerated.

4.8 Prefeasibility Analysis

Prefeasibility analysis starts from the requirements determined in the capability requirements analysis stage. The analysis considers the scope of possible responses to the requirements statement and examines options for delivering them. A preferred option or small range of options is selected. It is important not to get emotionally committed to a particular option too early in the analysis. Prefeasibility analysis may indicate that some aspects of the capability requirements statement require review, resulting in reference back to the requirements planning stage.

The result of the analysis is a prefeasibility plan and an initial business proposal for the project. The proposal seeks approval to proceed to the feasibility analysis stage where a fully detailed and costed plan will be developed. The selection of a specific supplier will normally remain open at this point.

² ISO 55001 Clause 6.2.2 Planning to achieve asset management objectives: “The organization shall integrate planning to achieve asset management objectives with other...planning activities....”

Fig. 4.9 Prefeasibility and feasibility analysis stages

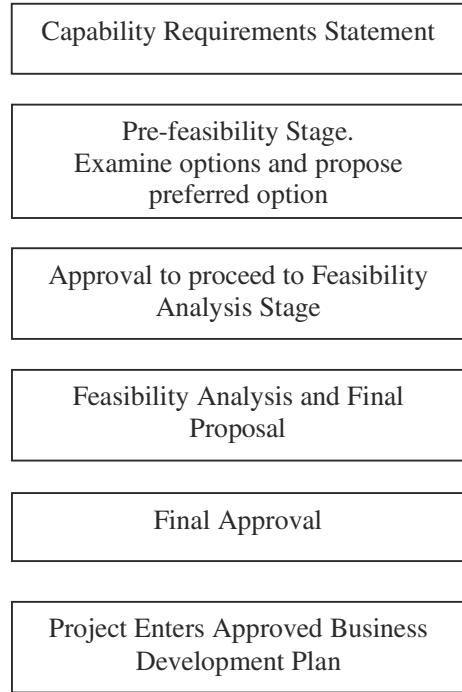

4.9 Feasibility Analysis

If the prefeasibility plan for a project is approved, the project enters the feasibility planning stage. Here the plans for the preferred option from the prefeasibility stage are subject to detailed analysis and costing. A feasibility planning project team will develop the analysis and there will be a broader stakeholder review which will provide feedback to the project team.

The result of feasibility planning is a development plan and a final business proposal. If this leads to a final decision to proceed, the project then enters the approved business development plan and moves forward to the physical acquisition or implementation phase.

4.10 Development Plan

The development plan will indicate what assets are planned to be acquired and when. In Fig. 4.10 the heavy line at the top shows a series of planned acquisitions which will be sufficient to keep capacity at a satisfactory level. A significant amount of supporting analysis and detail will normally accompany the plan, and we consider aspects of this in more detail in subsequent sections.

Fig. 4.10 Asset development plan

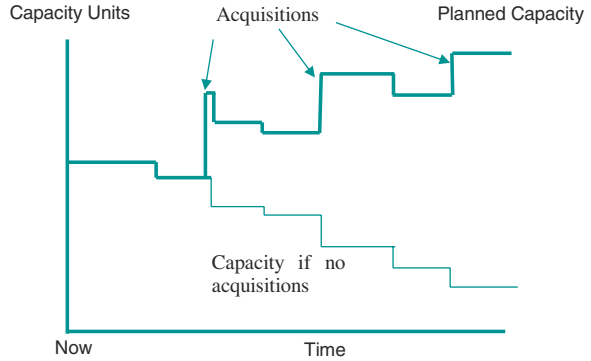

4.11 Development Plan Detailed Topics

The following is a list of topics which are typically covered in the development plan.

General Summary

- Title of plan
- Aims and scope
- Financial returns and costs
- Finance requirements and provision
- Schedule, date of decision
- Implementation and acquisition strategy and possible suppliers
- Risks
- Business case
- Prioritization

Requirements

- Land
- Civil works
- Buildings
- Machinery, equipment
- Tools, furniture, sundries
- Vehicles
- Facilities and resources
- Information technology
- Cleanup and restoration
- Disposal
- Capital costs
- Net operating costs
- Net people requirement
- Maintenance costs

- Materials
- Training
- Contingency allowance

Technical and Logistics

- Test and evaluation
- Project costs
- Maintenance concept
- Logistic support concept
- Life duration estimate
- Life cycle costs
- Health, safety, and regulatory considerations
- Associated changes or impacts

Background

- Stakeholders
- Assumptions
- Data analysis process
- Measure of success

The maturity of the feasibility stage can be assessed with the aid of the table shown in Fig. 4.13.

4.12 Considerations in Development Planning

4.12.1 Stakeholders³

Identify the stakeholders, that is, those people and functions that will be affected by the proposed plan. Survey their opinions and take them into account in developing, or even abandoning the plan. If necessary form a stakeholder committee. It is important to the success of any project that the stakeholders buy into the plan. Figure 4.11 shows some typical stakeholder groups.

For asset developments, the stakeholders normally include the relevant business, operations, and maintenance managers and staff. Where customers and suppliers are affected they will potentially form part of the stakeholder group, subject to business confidentiality. The plan is more likely to succeed if all the relevant groups have contributed to its development. At the same time, some stakeholders may resist the plan, particularly if they see it working against their interest, and it will be necessary to use management judgement and authority to present the

³ ISO 55002 Clause 4.2 “The organization shall determine the stakeholders...the expectations of these stakeholders...”

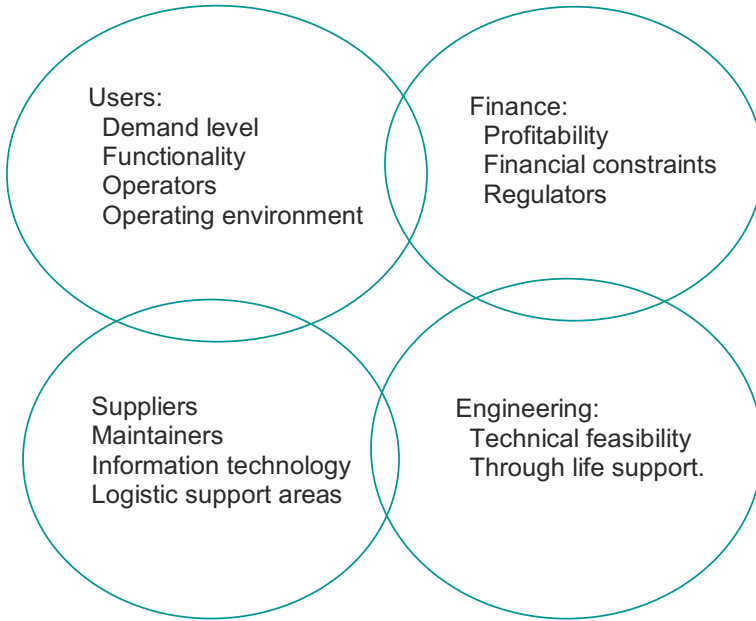

Fig. 4.11 Stakeholder groups

rationalization for the plan from the overall business viewpoint. But suffer fools gladly—they may be right.

4.12.2 Stakeholder Example

A modification to a machine is proposed which involves fitting a protective device designed to reduce rain and sun damage to exposed parts. This is estimated to prolong the life of the machine. The device will be fitted by maintenance staff during a servicing operation. Stakeholders involved are:

- Operations manager and operations superintendent—Production will prospectively benefit by extended machine life.
- Maintenance Superintendent—Reductions in scheduled maintenance and breakdowns are intended.
- Maintenance Department—Required to install the modification.
- Reliability Superintendent—Improvements in reliability and reduction in downtime will need to be estimated and later verified.
- Engineering—To confirm modification is technically acceptable. Involved in management of change.
- Stores Superintendent—Changed stockholding requirements.
- Component supplier.
- Financial—Approval of investment.

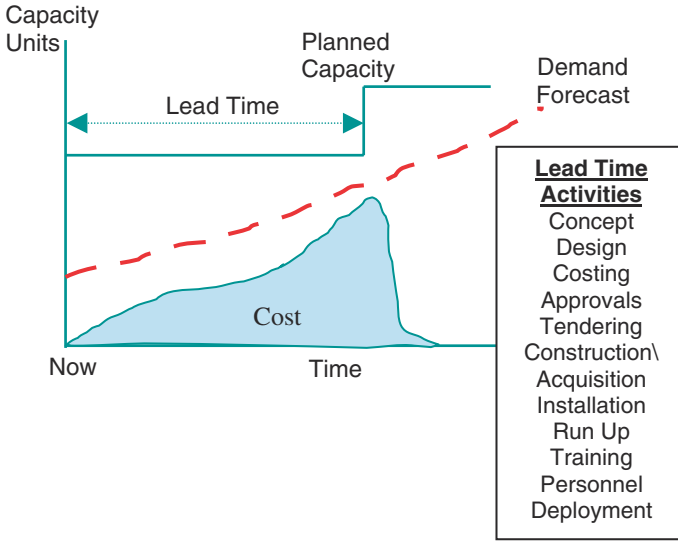

Fig. 4.12 Capital equipment lead time activities

4.12.3 Existing Processes and the Status Quo

In developing any plan it is important to be aware of the existing situation and the existing processes. Be sure to check out the existing situation and consult with stakeholders. Always consider the possibility of retaining the status quo, and use this as a basis for comparison.

4.12.4 Lead Time

An important factor in creating development plans is an appreciation of the amount of lead time required in order to introduce new equipment, and the range of activities which are essential to success. An indication of typical lead time activities is shown in Fig. 4.12.

4.12.5 In-Service Date

The Capability Requirements Statement will specify an “In-Service Date” as the date when a capability is planned to be available for service. This may be a single date or a range of dates in the case of a phased introduction. For a phased introduction we specify an Initial In-Service date and a Final In-Service date. An implementation timetable may also be needed. At the early stages, these dates

are preliminary estimates to be firmed up as the acquisition project proceeds. Awareness of the lead time activities and project progress will enable the project team to keep the end-user informed of potential changes to in-service dates. Adhering to the planned in-service date is a main target of the development team.

4.12.6 Date of Decision

To ensure an adequate focus on timing, it is desirable to specify a “date of decision” for the final approval of a project whilst it is in the capability requirements analysis and prefeasibility analysis stages. The many activities involved in an acquisition or development can easily be underestimated and this may result in the development not being completed in time to meet business needs.

4.12.7 Operational Concept Document

An operational concept document describes the characteristics of the proposed development in end-user terms. The simplest cases are expansions of existing functions. Other types of development may involve responses to new markets, new services, new technologies, or developments to existing services or processes. The development of this document will involve the operations group in working out how the new capability will be used and how it will work in with existing capability. This can involve market appraisal, technology appraisal, procedural appraisal, evaluation of competition, and financial appraisal.

Project studies may be undertaken to evaluate feasibility and potential profitability of probable options. For example, the organization may require an examination of capacity expansion options in terms of demand, revenue potential, technical options, staffing levels, and considerations of cost and timing, and disposal and redeployment.

The following factors are important in the development of the operational concept:

- a. Meet the market need in terms of key outputs, characteristics and features,
- b. Operationally practical,
- c. Technically feasible,
- d. Profitable,
- e. Affordable,
- f. Timing feasible,
- g. Technically supportable,
- h. No unsatisfactory risks,
- i. Reliability, availability, maintainability satisfactory,
- j. Meet design, environmental, health and safety standards,
- k. Life adequate,
- l. Retain some flexibility for revision as the acquisition develops.

4.12.8 Function and Performance Specifications

From the operational concept we develop functional and performance specifications for the key assets required. This about specifying how big, how strong, how many seats, how heavy, what power, what flow rate, how many bedrooms, how many bathrooms, how many garage spaces, what voltage, what noise level, etc., we require in the intended assets. Some features may be *essential* and some merely *desirable*. In developing specifications it is important not to get carried away and set specifications which are unachievable or will imply development work, unless development is a planned part of the project. Refer to existing performance standards and keep to modest variations.

4.12.8.1 Example

A specification for a new design of rotating turret for a vehicle required a rotational speed which was set to a high level without reference to existing performance standards. At the prefeasibility stage it became apparent that to achieve this performance would require a radical redesign of the drive system and quite infeasible changes to the vehicle body. Reference back to the capability requirements team showed that, once they related their specification to existing systems, they were quite happy to accept a rotational speed comparable to existing best practice, rather than the wildly optimistic number originally specified.

4.12.9 Level of Service⁴

Level of service relates to setting standards in such areas as performance, availability, reliability, timeliness of response, and provision of information when problems arise. Level of service relates to corresponding performance indicators. As an example, in a railway system, a performance indicator is the proportion of services that are not canceled due to train unavailability, and a corresponding level of service is a specification that this should be, say, 97 % or more.

4.12.10 Scope of Work

The scope of work details the work to be done and/or acquisitions to be made. This will be refined as the project firms up and will ultimately form a basis for procurement level costing and contracting.

⁴ ISO 55000 Clause 3.3.6.

4.12.11 Financial Analysis

Preliminary appraisals of revenue potential, costs, and profitability will be carried out and will be refined as the proposal proceeds. The analysis will be supported by data and estimates and a statement of assumptions, including the following:

- Demand forecast
- Revenue forecast
- Personnel and operating cost
- Equipment life cycle cost estimate
- Profit and Loss projection
- Cash Flow projection
- Balance Sheet projection
- Payback period, Internal rate of return
- Sensitivity analysis in regard to assumptions, particularly demand and costs
- Identification of major risks, business, technical, and regulatory.

4.12.12 Acquisition Strategy

In considering acquisition and development options it is important to ensure that they are feasible from a delivery point of view. A development team may be over-optimistic in assessing what the suppliers can supply and what the developers can develop, within a given timescale and cost envelope.

A danger lies in assuming that an acquisition is of an off-the-shelf nature when in fact it requires adaptation to suit our needs. In this case it is advisable to undertake the adaptation as a separate project, and only to proceed to the main project when we are sure that our needs can be met within desired business parameters.

Another factor is the availability of resources to implement any acquisition or development plan. This includes consideration of the availability of personnel for design and development functions, for equipment specification and evaluation and for cost analysis, legal and financial support and engineering support for acquisition and system implementation. Restrictions in these areas may be critical in reducing the range of projects that can be undertaken.

A summary of points relating to the acquisition strategy is as follows:

- a. What potential suppliers are available?
- b. How extensively should we canvas for potential suppliers?
- c. Do the potential suppliers have the necessary technical depth and logistic support strength?
- d. Should we adopt a preferred supplier list? If not, is there a danger of excessive logistic diversity or of attracting suppliers with insufficient technical backup?
- e. Should we go to open tender?
- f. Should we sole source?

- g. Is the item available “off the shelf”?
- h. Is development work required?
- i. Should the acquisition/development be phased?
- j. If phased, will changes to the equipment over the phases be a problem?
- k. Should the acquisition be evolutionary, allowing for possible equipment improvement over the acquisition process?
- l. Are there maintenance issues? Is a support contract available? Is outsourcing a consideration?
- m. What major logistic issues are there?

4.13 Project Maturity

At any given point in time a number of projects will be in the feasibility Planning Portfolio. Figure 4.13 shows a scoring system which enables management to track the maturity status of these projects. As a project matures its total maturity score will progress toward 25 and we can monitor progress and manage priorities by reference to the maturity score at any point.

4.14 Implementation Portfolio

The result of feasibility planning is a development plan and a final business proposal. If this leads to a decision to proceed, the project then enters the approved business development plan and moves forward to the implementation portfolio. The Implementation Portfolio consists of the set of acquisition or development projects which have been approved for development and are in progress, but not yet handed over to operations. The steps in the journey from initial idea to asset delivery and ultimate disposal are summarized in Fig. 4.14. The implementation phase of a project is considered in a later chapter.

Maturity Score	Business Status	Technical Difficulty	Cost	Schedule	Operations and Support
5	Firm	Minimal	Firm	Confirmed	Planned
4	Understood	Manageable	Estimated	Understood	Known
3	Feasible	Feasible	Contingent	Activities Identified	Understood
2	Plausible	Speculative	Speculative	Speculative	Conceptual
1	Exploratory	Unknown	Unknown	Unknown	Not identified

Fig. 4.13 Feasibility stage maturity status scoring

Development concept and capability requirement perceived
Capability requirements planning project approved, enters Requirements Portfolio
Forecasting, Needs analysis, Un-augmented capability analysis including retirement of older existing facilities, Capability gap analysis
Capability requirements statement established
Pre-feasibility project approved, project enters Pre-Feasibility Portfolio
Pre-feasibility project executed, examine options, initial financial analysis, date of decision
Initial business proposal
Preliminary approval
Feasibility analysis project approved, project enters Feasibility Portfolio
Feasibility analysis of preferred option, test and evaluation work, acquisition strategy, selection criteria, logistic support plan, financial analysis. Change management, risk management and site modification requirements assessed
Final business case
Project approval, project enters Implementation Portfolio
Acquisition/Development project established
Acquisition/Development process, request for tender developed and released, tendering, tender evaluation, equipment trials, supplier selection
Pre-contract negotiation, Contract acceptance
Training developed
Logistic support developed
Commissioning, Equipment pre-acceptance checks
Acceptance
Operational readiness, introduction into service
Hand over to user. Change management process enacted
Acquisition/Development implementation complete
Sustainment process operational
Operations and sustainment activities on-going
Configuration management, Performance monitoring, Condition monitoring
Defect reporting, analysis and corrective action as determined
Replacement planning
Disposal

Fig. 4.14 Steps in the asset management process

4.15 Exercises

4.15.1 Self-Assessment Quiz 4.1

1. Identify five reasons for initiating an asset-based development project.
2. Identify four different types of asset acquisition or development process which may be required in a project.
3. Identify the main stages of development of an asset acquisition project.

4. Define “capability” in an asset management sense.
5. Identify six inputs to capability.
6. Define *capability gap analysis*.

4.15.2 Self-Assessment Quiz 4.2

1. Asset planning involves forecasting of future demand. Give examples of considerations that are involved in forecasting.
2. What is meant by the Date of Decision and how is it derived?
3. List five activities that typically are required in the lead up to the use of a major asset.
4. What is an Operational Concept Document? Identify six factors that are important in its development.
5. Identify six factors that may be considered in formulating an acquisition strategy.
6. What is the difference between prefeasibility analysis and feasibility analysis?

4.15.3 Capacity Planning—Generators

4.15.3.1 Gap Analysis

An electricity generation company is considering developments for power generation over the period from 5 to 8 years ahead. A forecast of demand including reserve capacity indicates that demand will be for 5.2 Gigawatts (GW) in year 5, increasing at 10 % per annum compound over the remainder of the planning period. A projection of generating capacity available from existing sources is for 4.8 GW to be available in years 5 and 6, decreasing by 0.6 GW per year in years 7 and 8.

Calculate the following for each year of the planning period using a tabular format.

- Year
- Needs
- Un-augmented capacity
- Capacity gap.

4.15.3.2 Prefeasibility Planning and Options

Two options for covering the generating capacity gap are to be considered. These are,

- a. adding generator capacity in 600 MW units at the minimal rate to cover the forecast demand, at a cost of \$1 billion per unit, with a lead time of 3 years.
- b. adding capacity by building 2 GW power stations at a cost of \$2.7 billion each with a lead time of 4 years.

Extend your tabular format to develop plans for the two options. Discuss the financial and practical merits of two options and of other possible options. What major elements of capability would be likely to be required besides the generators?

4.15.4 Bottling Plant Exercise

A bottling plant has four old bottling production lines which need 48 h a week of scheduled operating time to meet demand. Unscheduled downtime has been eating into planned production time recently. A business development review finds that there is steady demand for the existing product, but that there is growing demand for bottles with a screw-top closure. A range of new equipment at various costs and levels of performance is available on the market. At present there are six mechanics, but several are nearing retirement and mechanics with suitable skills are not readily available. What should you do?

4.15.5 Own Project Exercise

1. Identify and briefly outline a project for a potential asset based development or improvement related to your workplace.
2. Identify existing procedures and/or documentation within your organization relating to decisions regarding asset acquisitions or developments, including financial or business case requirements and logistic support aspects.
3. Write an outline of the potential project that you have identified. This should include:
 - The title of your proposed project
 - The current situation addressed by your project
 - The desired future state
 - Proposed methods of progressing the project
 - The potential estimated value of the project
 - A summary of procedures or documentation relevant to advancing the proposal within your organisation.

4.16 Exercise Solutions

4.16.1 Self-Assessment Quiz 4.1 Solutions

1. *Identify five reasons for initiating an asset-based development project.*
Refer to Sect. 4.1, where the following reasons are listed:
 - a. Capacity creation, expansion, reduction, or consolidation
 - b. Renewal or updating of existing capacity

- c. New business directions
 - d. Process improvement
 - e. De-bottlenecking
 - f. Protection of assets
 - g. Technical developments, internally and externally
 - h. Environmental or safety improvements
 - i. Response to regulatory changes.
2. *Identify four different types of asset acquisition or development process which may be required in a project.*
Refer to Sect. 4.2 where the following are identified:
- a. Off-the-shelf acquisition
 - b. Business development but not primarily acquisition
 - c. Design incorporating selection of off-the-shelf items
 - d. Design from the drawing board but standard technology
 - e. Introduction of technical change
 - f. Design with developmental technology
 - g. Research and development.
3. *Identify the main stages of development of an asset acquisition project.*
Section 4.3.1 gives a brief list and Fig. 4.14 gives a more detailed list. An answer based on Sect. 4.3.1 is as follows:
- Project initiation
 - Capability requirements analysis
 - Prefeasibility analysis—identify options
 - Feasibility analysis—detailed plan
 - Project approval
 - Implementation.
4. *Define “capability” in an asset management sense.*
Capability is the ability of a system to meet a specified need in all its aspects. That is, it covers the combined concepts of capacity and ability, including all the assets and associated personnel, resources, and services which are required to meet the need.
5. *Identify six inputs to capability.*
Any six entries in the boxes in Fig. 4.2.
6. *Define capability gap analysis.*
Capability Gap Analysis is the process of identifying the gap between the capability required to deliver the business objective and the existing or planned capability.

4.16.2 Self-Assessment Quiz 4.2 Solutions

1. *Asset planning involves forecasting of future demand. Give examples of considerations that are involved in forecasting.*

Refer to Sect. 4.5.2. Factors are:

- asset knowledge
 - existing level of demand
 - technical trends
 - current trends
 - known factors, e.g., urban growth
 - seasonality
 - one-off changes
 - actions of governments
 - outliers
 - retain flexibility.
2. *What is meant by the Date of Decision and how is it derived?*
- Year of Decision—the year when a replacement decision needs to be made in order to allow time for the acquisition lead time activities. It is derived by estimating the “year of expiry,” which is when an asset should be replaced, and then subtracting the acquisition lead time. See Fig. 4.12.
3. *List five activities that typically are required in the lead up to the use of a major asset.*

These are listed in Fig. 4.12. Here is the full list from the figure.

- Concept
 - Design
 - Costing
 - Approvals
 - Tendering
 - Construction\Acquisition
 - Installation
 - Run Up
 - Training
 - Personnel Deployment.
4. *What is an Operational Concept Document? Identify six factors that are important in its development.*

An operational concept document describes the characteristics of the proposed development in end-user terms. Further description is in Sect. 4.12.5.

The following factors are important in the development of the operational concept:

- a. Meet the market need in terms of key outputs, characteristics and features,
 - b. Operationally practical
 - c. Technically feasible,
 - d. Technically supportable
 - e. Profitable,
 - f. Affordable,
 - g. Timing feasible
 - h. No unsatisfactory risks,
 - i. Reliability, availability, maintainability satisfactory
 - j. Meet design, environmental, health and safety standards
 - k. Life adequate
 - l. Retain some flexibility for revision as the acquisition develops.
5. *Identify six factors that may be considered in formulating an acquisition strategy*
- Refer to Sect. 4.12.10. The factors listed there are as follows:
- a. What potential suppliers are available?
 - b. How extensively should we canvas for potential suppliers?
 - c. Do the potential suppliers have the necessary technical depth and logistic support strength?
 - d. Should we adopt a preferred supplier list? If not, is there a danger of excessive logistic diversity or of attracting suppliers with insufficient technical backup?
 - e. Should we go to open tender?
 - f. Should we sole source?
 - g. Is the item available “off the shelf”?
 - h. Is development work required?
 - i. Should the acquisition/development be phased?
 - j. If phased, will changes to the equipment over the phases be a problem?
 - k. Should the acquisition be evolutionary, allowing for possible equipment improvement over the acquisition process?
 - l. Are there maintenance issues? Is a support contract available? Is outsourcing a consideration?
 - m. What major logistic issues are there?
6. *What is the difference between prefeasibility analysis and feasibility analysis?*
- Prefeasibility analysis considers the scope of possible responses to a requirements statement and examines options for delivering them. A preferred option or small range of options is selected. Feasibility analysis is creating and costing a plan for the preferred option, with a view to making a decision to proceed or not.

4.17 Capacity Planning Exercise Generators—Solution

The preplan gap analysis is shown in Fig. 4.15, rows 1–4. The total gap of 3.32 GW gives an indication of the minimum additional capacity required over the planning period and can be a useful guide in selecting options for the prefeasibility analysis. Figure 4.15 also shows the calculations for Option 1. Figure 4.16 shows the calculations for Option 2. Option 2 is cheaper, but Option 1 offers more flexibility in the event that the needs forecast turns out to be inaccurate. A combination of the two sizes of generator might offer a better combination of flexibility and cost.

	A	B	C	D	E	F
1	Years from Now, i	5	6	7	8	Total
2	Forecast capacity needed GW.	5.2	5.72	6.29	6.92	
3	Un-augmented capacity available	4.8	4.8	4.2	3.6	
4	Pre-plan Gap	0.4	0.92	2.09	3.32	
5	Capacity before install. Row5(i-1)+Row7(i-1)-(Row3(i-1)- Row3(i))	4.8	5.4	5.4	6	
6	Gap before install. Row2 - Row5	0.40	0.32	0.89	0.92	
7	Install qty GW	0.6	0.6	1.2	1.2	3.6
8	Install cost \$billion	1	1	2	2	6
9	Year of decision, i-3	2	3	4	5	

Fig. 4.15 Generator capacity planning option 1

	A	B	C	D	E	F
1	Years from Now, i	5	6	7	8	Total
2	Forecast capacity needed GW.	5.2	5.72	6.29	6.92	
3	Un-augmented capacity available	4.8	4.8	4.2	3.6	
4	Pre-plan Gap	0.4	0.92	2.09	3.32	
5	Capacity before install. Row5(i-1)+Row7(i-1)- (Row3(i-1)-Row3(i))	4.8	6.8	6.2	7.6	
6	Gap before install. Row2 - Row5	0.40	-1.08	0.09	-0.68	
7	Install qty GW	2	0	2	0	4
8	Install cost \$billion	2.7	0	2.7	0	5.4
9	Year of decision, i-3	1	0	3		

Fig. 4.16 Generator capacity planning option 2

Additional aspects of capability include; physical site availability and features; fuel supply and handling equipment; cooling water; power transformers; transmission and distribution requirements; etc.

4.18 Bottling Plant Exercise Solution

Concept stage Formalize the projected demand over a planning period of several years ahead. Consider competition which may affect market share and total revenue. Try to determine the expectations of major customers and potential customers. Estimate the revenue from meeting demand and costs of meeting demand at a concept level. If further analysis seems worthwhile proceed to the next stage.

Prefeasibility analysis Get data on available bottling machines, new, and possibly second hand. Determine acquisition costs, operating costs, maintenance costs, and production capacity.

Consider the physical and financial characteristics of options including:

- Continue with existing system, reviewing maintenance policy for possible improvements.
- Replace oldest or most troublesome machines to improve reliability.
- Acquire new machines, considering configurations to address the old and new markets.

If the prefeasibility analysis looks promising proceed to the next stage.

Feasibility analysis Review the options and select a preferred option, possibly involving some combination of those outlined. Develop the plan in detail for the preferred option, including acquisition strategy (e.g., supplier options, shortlist of suppliers, tendering procedure if any) installation requirements, staffing requirements, maintenance and logistic support requirements, financial analysis. Bring this together into a business case and seek approval. If the plan is approved proceed to the next stage.

Acquisition process Acquire, install, commission, train, introduce into service.

Operational phase Operations proceed with new more reliable equipment, reducing the maintenance requirement, increasing production capacity and addressing the new market for screw-top bottles. Enjoy the financial benefits.

4.19 A Business Imperative

Jock and Sheila's trip to look at the blocks of land was not as successful as they had hoped. The prices were much higher than they had anticipated and the best blocks had already gone. They renewed the lease on their apartment and things

drifted on for several months. Then one day Jock got in from work to find that Sheila was already home and looking excited.

“You’re home early,” said Jock.

“Look at me,” said Sheila.

As he was already looking at her, this involved no special effort on Jock’s part.

“So,” he said.

“It’s happened!” said Sheila.

With no further response from Jock she gave him a “men are so dumb” look and said,

I’m pregnant!

Jock picked her up and whirled her around.

“Careful!” she said.

He put her down gently.

“Wow,” he said.

A little while later, Sheila said,

We are going to have to get on with buying a house. We will need three bedrooms, or maybe four—and a new car.

“We won’t need so many bedrooms at the start,” said Jock, “and why do we need a new car?”

Well we can hardly put a baby seat in that ridiculous two-seater, and we will need room for a pram and baby things. I think we’ll have to get a hatch-back.

Jock gave a slight groan.

“Aren’t you pleased?” said Sheila looking hurt.

“Of course,” said Jock, and he thought about the Capability Development Team that he was involved in for the process plant expansion at work.

His mind turned back to the impending baby. It wasn’t the technicalities that worried him. It was the money.

“Maybe I can get the job of Project Leader for the next Feasibility study” he said, half out loud.

“This isn’t one of those work projects that you spend all your time thinking about,” said Sheila. “It’s a baby and it’s ours.”

He gave her another hug.

Chapter 5

Financial Methods

The hardest part of financial analysis is not the calculations, but deciding what factors should be taken into account and estimating the costs, revenues and risks.

Abstract The aim of this chapter is to introduce the concepts of discounted cash flow in the context of asset management decisions to see how these are applied in establishing asset investment criteria. Asset managers need to have a working knowledge of business finance so they can provide input to business decisions. *Outcomes* After reading this chapter you will know about:

- Interest rates
- The time value of money
- Present value(PV) and net present value(NPV)
- The discount factor
- Cash flow diagrams
- Equivalent annual cost and equivalent unit cost
- The use of Excel financial functions
- The annuity factor and the capital recovery factor
- Asset investment criteria
- Payback period
- Internal rate of return
- Minimum acceptable rate of return

5.1 Introduction¹

Asset management decisions involve the application of a combination of technical and financial knowledge. Asset managers play a key role in ensuring that the physical facts and the financial and cost data which are used in making asset management decisions

¹ ISO 55002 Clause 6.2 'Asset management objectives and planning to achieve them,' and sub-clause 6.2.1.3, indicate a requirement for consideration of financial analysis methods including net PV and return on investment.

are sufficiently accurate and sufficiently well aligned so that sound decisions can be made. To carry out these functions successfully, asset managers need to be familiar with the language and methods of accounting and financial analysis.²

In this chapter, we shall introduce a range of methods of financial analysis and shall illustrate them by asset-related examples. In practice, these methods are used to assess whether particular projects are financially worthwhile, and if so, to support the business case for the projects. By adopting standard methods of financial analysis, we can evaluate and compare projects in a consistent manner. These standard financial analysis methods also provide the basis for good communication between asset managers and financial analysts. Financial methods are developed further in later chapters.

5.2 Discounted Cash Flow

Fixed assets such as buildings, infrastructure, and plant have lives extending over many years. Discounted cash flow analysis is a method of analyzing cash flows over a period of years, which takes account of the time value of money. The topic involves the concepts of interest rate, discount factor, present value (PV), cash flow diagrams, and equivalent annual cost (EAC). We shall study these concepts in an asset management context and also use Excel spreadsheet functions to calculate discounted cash flow quantities.

An example of the application of discounted cash flow that we encounter in everyday life is the repayment of a loan for a motor vehicle purchase. This involves borrowing money and then repaying the initial capital and also the interest on the outstanding loan, so that ultimately both capital and interest costs are covered. Another similar example is the repayment of a mortgage.

5.2.1 Interest Rate

The interest rate is the cost or return per year of either borrowing or lending money, expressed as either a decimal fraction or a percentage of the amount borrowed or lent. The interest rate on borrowing is higher than on lending, the difference being the bank's margin or source of income.

An industrial project will only be worthwhile if the return on it exceeds the return which we could get on a safe investment such as a bank deposit or government bonds. The return must also be high enough to cover the cost involved in carrying out the project, the risk that all may not go according to plan and to provide a profit in return for the effort involved. For information on the interest rate applicable to particular asset-related calculations, it is advisable to consult your finance personnel. For calculation purposes it is easy to change an interest rate in a spreadsheet and to assess the sensitivity of a calculation to different interest rates.

² ISO 55001 Clause 7.5 Information Requirements: "The organization shall determine the requirements for alignment with financial... terminology..."

"The organization shall ensure there is consistency...between financial and technical data...".

5.2.2 Present Value (PV)

The PV of an amount of money V_n received in n years time is the amount of money available now which will attain the value V_n if invested at interest over the intervening years. For an interest rate r , the present value, PV, of an amount V_1 received in 1 year's time is given by the equation:

$$PV = V_1 / (1 + r) \quad (5.1)$$

Thus, with an interest rate of 10 %, the PV of \$100 received in 1 year's time is:

$$PV = 100 / (1 + 0.1) = \$90.91 \quad (5.2)$$

For an amount V_n received in n years time, the PV is given by:

$$PV = V_n / (1 + r)^n \quad (5.3)$$

5.2.2.1 Why Consider Present Value?

The reason why we need to consider PV is that asset investments often only pay off over a period of years. We need to take account of this delay factor in making asset management decisions.

5.2.3 Discount Factor

The multiplier $1/(1 + r)$ which occurs in Eqs. 5.1–5.3, arises frequently in discounted cash flow analysis and is known as the discount factor. The discount factor is the proportion by which an amount is reduced to give its equivalent value 1 year earlier. We shall denote the discount factor by the symbol p . Then:

$$p = 1 / (1 + r) \quad (5.4)$$

Using the discount factor, p , the PV of an amount V_n received in n years time is given by:

$$PV = p^n * V_n \quad (5.5)$$

Example: Calculate the PV of \$100 received in 2 years time, with an interest rate of 10 %.

Solution: For an interest rate of 10 %,

$$p = 1 / (1 + 0.1) = 0.9091 \quad (5.6)$$

$$PV = p^2 * V_2 = 0.9091^2 * 100 = \$82.64 \quad (5.7)$$

We see that \$100 received in 2 years time only has the same value as \$82.64 received now, assuming a 10 % interest rate.

5.2.4 Net Present Value (NPV)

The NPV of a series amounts received or expended over a number of years is the sum of the PV of the amounts. For a series of amounts $\$V_i$ received in i years time, the Net Present Value, NPV, is the amount of money available now which is equal to the value of the series, allowing for the interest rate.

$$\text{NPV} = V_0 + pV_1 + p^2V_2 + \dots + p^nV_n \quad (5.8)$$

5.2.4.1 Example

As an example, consider receiving \$100 in 1 year's time and then another \$100 in 2 years time. If the interest rate is 10 %, the discount factor will be as given by Eq. 5.6, that is $p = 0.9091$. Using the symbols of Eq. 5.8 we have:

$$V_0 = 0, \quad V_1 = 100, \quad V_2 = 100, \quad p = 0.9091.$$

$$\text{NPV} = 0 + 0.9091 \times 100 + 0.9091^2 \times 100 = \$173.55. \quad (5.9)$$

Thus the NPV of the amounts received is \$173.55. In other words, \$100 received in 1 year's time plus \$100 received in 2 years time has the same value as \$173.55 received right now, if the interest rate is 10 %.

5.2.4.2 Cash Flow

A cash flow is an amount of money that we receive or expend. Money received is a positive cash flow and expenditures are negative cash flows. In the example just given, both cash flows were positive. More generally, in NPV calculations some of the cash flows may be positive and some negative.

5.2.4.3 Why Consider NPV?

The reason why we need to consider NPV is that asset investments often involve a series of expenditures and revenues over a period of years. We need to take account of amounts and timings of these cash flows in making asset management decisions. Use of the NPV allows us to put any series of cash flows onto a common basis.

5.2.5 Cash Flow Diagram

A cash flow diagram is a schematic representation of cash received and expended year by year in the course of an activity. A cash flow diagram is a convenient way of visualizing the income and expenditure in a project. As an example, consider the

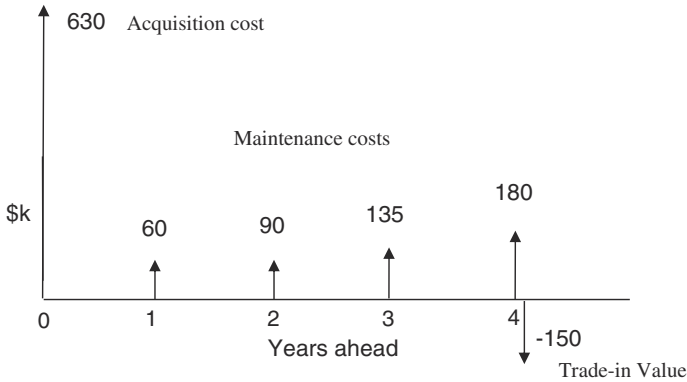

Fig. 5.1 Loader—cash flow diagram (\$k)

purchase, maintenance, and disposal of an earth moving machine called a loader. The following costs are incurred over the life cycle of the loader at the times indicated.

- Year 1 (beginning) \$630 k acquisition cost
- Year 1 (end) \$60 k maintenance cost
- Year 2 (end) \$90 k maintenance cost
- Year 3 (end) \$135 k maintenance cost
- Year 4 (end) \$180 k maintenance cost
- Year 4 (end) -\$150 k trade-in value.

We have assumed that the maintenance costs are end-of-year costs. This is not strictly accurate but adjusting for part year timings is usually not considered justified in this type of calculation. The cash flows can be represented as shown in Fig. 5.1.

The NPV of the cash flows in Fig. 5.1 can be calculated using Eq. 5.8. Prior to the widespread availability of spreadsheets, PV calculations were facilitated by the use of tables which give values of the n year discount factor, p^n , for various values of interest rate and numbers of years. Appendix shows an example of such a table. However, in current practice we are likely to use a spreadsheet such as Excel for this type of calculation so we shall illustrate the use of the Excel NPV function.

5.2.6 Excel Function NPV

In Fig. 5.2 the Excel function NPV is used to calculate the NPV of the life cycle costs for the loader. The costs are as shown in Fig. 5.1. In the spreadsheet, Fig. 5.2, cells B3–F3 show the acquisition and maintenance costs of the loader. Note that the net cost in year 4 was entered, that is the maintenance cost minus the trade-in value. The interest rate in this case was 9 % and this value is shown at cell B1.

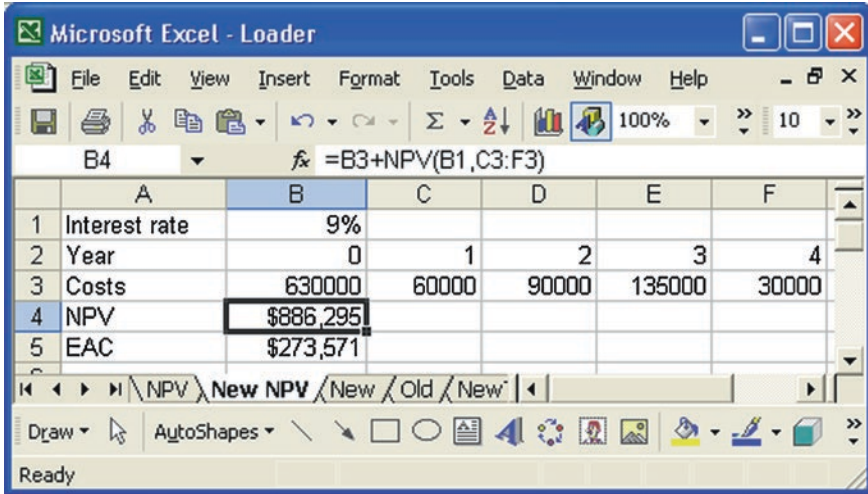

Fig. 5.2 NPV of life cycle cost of a new loader

The format of the NPV function is illustrated in the function field in Fig. 5.2. The Excel NPV function calculates the NPV of a series of values at a given interest rate, for annual payments starting in 1 year’s time. An initial cost, which is undiscounted, in this case the acquisition cost from cell B3, must be shown separately from the range of values supplied to the NPV function.

From the spreadsheet, we see that the NPV of the life cycle cost is \$886,295, shown at cell B4.

5.2.6.1 Applications of the NPV

The NPV is useful in understanding the total cost involved over the life cycle of the machine and in relating it to revenue factors, such as the value of the work done by the machine in its life time. The NPV of the life cycle cost can be used to compare rival types of machine, with the machine with the lowest NPV being the one to be preferred, provided that the performance is similar. In making comparisons, we must be careful to ensure that the comparison is fair in terms of factors such as the productive capacity of rival machines.

5.2.7 Equivalent Annual Cost (EAC)

EAC is the amount of a regular annual cost which, over a given period of years, has the same NPV as any given series of costs. The EAC converts the NPV into an equivalent annual amount. The term Equivalent Annual Value (EAV) is also be

used when income as well as cost is considered. An example of an EAC is a mortgage repayment made at a regular amount per year. The NPV of the payments over the whole period adds up to the amount of the original loan plus the interest payments on the loan.

5.2.7.1 Why Do We Calculate the EAC?

EAC is a useful concept in asset management. It helps in the comparison of options, particularly where the options are dissimilar in type or duration. The difference between two options can often be more easily appreciated, particularly in relation to external or risk factors, when converted into an annual cost. Examples are in comparing life cycle costs of different items, or of similar items over different lives, and comparing the value or cost of competing projects with different durations. For example, in deciding on a house purchase we look at the capital cost, but also we focus on the monthly mortgage repayments and whether we can afford them from our income. This is essentially an “EAC” assessment.

5.2.7.2 Excel Function PMT

We can use the Excel function PMT to calculate an EAC. The name PMT derives from the word “payment”. In Fig. 5.3 the Excel function PMT is used to calculate the EAC of the loader, using the data in Fig. 5.2. The function field shows the format of the Excel function PMT. The PMT function value takes the opposite sign to the NPV, and the minus sign in front of the function gives the EAC the same sign as the NPV.

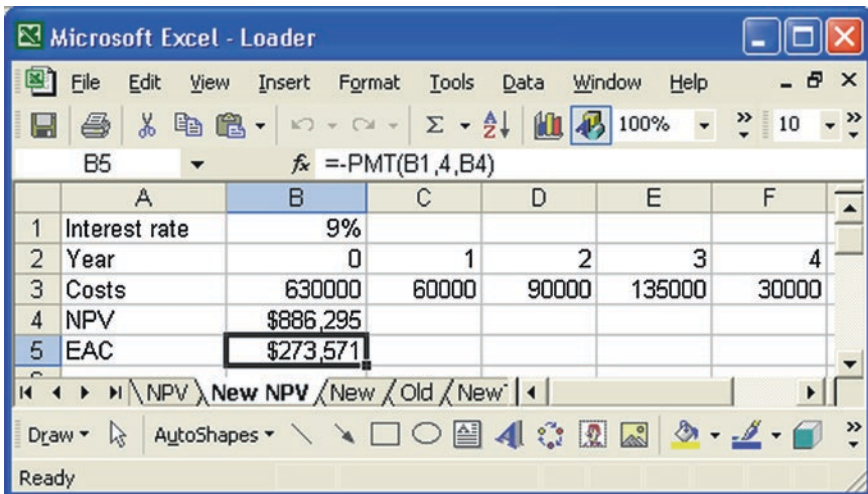
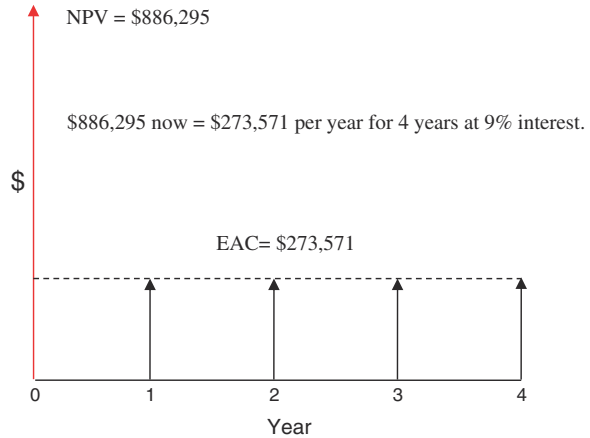

Fig. 5.3 Loader EAC using PMT function

Fig. 5.4 Net present value and equivalent annual cost



In Fig. 5.3, cell B1 shows the interest rate at 9 % and cells B3–F3 show the acquisition and maintenance costs of the loader as before. Cell B5 shows the EAC for the loader, which is \$273,571 per year. The EAC provides information to supplement that provided by the NPV, and is useful in asset management decisions such as comparing with possible leasing costs and in replacement decisions.

5.2.8 Relationship Between EAC and NPV

In Fig. 5.3, cells B4 and B5 show the NPV (\$886,295) and the EAC (\$273,571 per year) for the loader, respectively. Figure 5.4 illustrates the relationship between the NPV and the EAC, with the NPV being the NPV of the series of costs represented by the EAC over the specified life cycle.

5.3 Other Financial Terms

Here are some other financial terms which may be encountered in an asset management context.

5.3.1 Annuity Factor

The annuity factor is the NPV of an amount of \$1 per year, received for n years, with the first dollar being received in 1 year's time, at a specified interest rate. The relationship between the NPV and the EAC is:

$$\text{EAC} = \text{NPV}/\text{Annuity Factor} \quad (5.10)$$

Prior to the widespread availability of spreadsheets, tables of the annuity factor were used to calculate the EAC from the NPV. An example of such a table is given in Appendix.

5.3.2 Capital Recovery Factor

The Capital Recovery Factor, C , is the reciprocal of the Annuity Factor. It is the amount we need to receive per year for n years to have an NPV of \$1 at the specified interest rate. The Capital Recovery Factor is the amount that must be paid each year over the given repayment period, per dollar of initial capital, in order to repay that capital and the interest on the outstanding capital at each stage. These concepts are related by the following equations:

$$\text{Capital Recovery Factor} = 1/\text{Annuity Factor} \quad (5.11)$$

$$\text{EAC} = \text{NPV} * \text{Capital Recovery Factor} \quad (5.12)$$

5.3.3 Equivalent Unit Cost (EUC)

Sometimes we need to make comparisons between items which serve similar purposes but have different capacities. For example, we may be deciding whether to purchase haulage trucks of 50 or 200 tonne capacity. The concept of EUC is useful here. The EUC is the EAC divided by the number of units of production which the item has capacity to generate, per year. For comparison purposes, we will need to make standardizing assumptions for each of the relevant items, such as how many shifts are worked by each type of equipment. We refer to the productive capacity per year as the Annual Production Capacity (APC). The EUC is then given by:

$$\text{Equiv. Unit Cost} = \text{Equiv. Annual Cost}/\text{Annual Production Capacity} \quad (5.13)$$

5.4 Asset Investment Criteria

In this section, we describe the methods used in evaluating the financial merits of investments in physical assets and illustrate these by examples. The examples used are intended to illustrate the principles involved and it will be understood that practical situations typically involve more detail and a wider range of relevant factors, including possibly less readily costable benefits. The investments that we are considering may be of a variety of types, including asset acquisitions,

modifications, upgrades, overhauls, or other improvements to existing plant or facilities. Topics dealt with include the following:

- Net present value
- Payback period
- Internal rate of return
- Excel function IRR
- Minimum acceptable rate of return
- Profitability index
- Discussion of project financial measures
- Comparison and selection of projects
- Planning horizon

5.4.1 Net Present Value

If we are to invest in an acquisition or development, key financial questions are;

- what returns can we expect?
- when can we expect to get them?
- will the investment be worthwhile?

The NPV tells us what an investment is worth. For an investment to be worthwhile, the NPV must be positive and it must also be sufficiently large to satisfy other criteria that we shall consider in this section.

A first step in any investment decision is usually to estimate the NPV of the investment, using the methods already detailed in Sect. 5.2, and in particular Eq. 5.8. An example is given as Exercise 5.5.1, NPV of Material Handling System, at the end of this chapter.

5.4.2 Payback Period

The payback period is the time required to recoup an investment. Suppose that we initially invest an amount V_0 in a given capability and that it generates returns V_1, V_2, V_3, \dots in years 1, 2, 3, ... The payback period is reached when the NPV of the sum of V_1, V_2, V_3, \dots first exceeds V_0 . An investment which has a short payback period is attractive because there is less risk that things will go wrong over a short time frame.

Use of the payback period avoids the difficulty of evaluating a long series of returns, since all we focus on is how quickly the series becomes positive.

Figure 5.5 illustrates the concept of the payback period.

An example is given as Exercise 5.5.2, Pay Back Period of Material Handling System, at the end of this chapter.

Fig. 5.5 Payback period cumulative plot

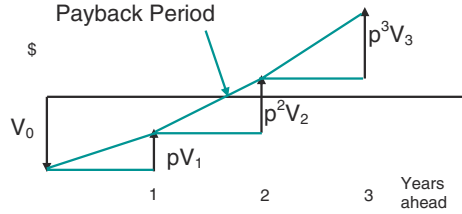

5.4.3 Internal Rate of Return (IRR)

Suppose that we invest an amount V_0 and that it generates returns $V_1, V_2, V_3, \dots, V_n$ in years 1, 2, 3, ..., n . The internal rate of return is the value of the interest rate which makes the present value of the sum of the returns exactly equal to the value of the initial investment.

Thus if,

$$V_0 = pV_1 + p^2V_2 + p^3V_3 + \dots + p^nV_n \tag{5.14}$$

Then p is the discount factor for which the corresponding interest rate is the internal rate of return (IRR).

This is illustrated in Fig. 5.6 which shows the initial investment and the cumulative discounted cash flow for its subsequent returns. The internal rate of return is the rate at which a project generates returns from the money invested in it. It is the return on the *unrecovered balances*, not the rate of return on the initial investment over the whole period of the project.

The internal rate of return (IRR) of a project provides a measure of profitability which can be compared with returns on other investments. The IRR calculation is also a form of risk analysis. The higher the IRR, the less susceptible the project is to risk.

5.4.3.1 Excel Function IRR

Calculation of the IRR is complex, as it involves solving Eq. 5.14 for the discount factor, p , and hence getting the value of the internal rate of return, r . Excel includes an IRR function which will carry out the necessary calculations. An illustration of the use of the Excel IRR function is given in the solution to the Communications System Exercise at the end of this chapter, Fig. 5.10.

Fig. 5.6 The internal rate of return makes the NPV equal to the initial investment

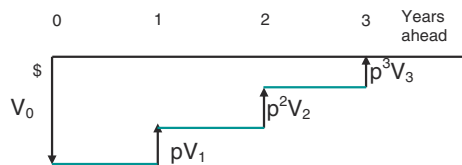

5.4.4 *Minimum Acceptable Rate of Return (MARR)*

It is common business practice to expect an investment to achieve at least a certain internal rate of return, if it is going to receive financial approval. This return is known as the Minimum Acceptable Rate of Return (MARR) or as the Hurdle Rate. The minimum acceptable rate of return is a return which will cover:

- the costs incurred in carrying out the project,
- the cost of capital, including both the interest charged and the repayment of the capital over the period of the investment,
- an element of profit on the project,
- an allowance for risk.

Typically, this leads to a MARR of not less than 15 %.

An example of a MARR calculation is given in the solution to the Communications System Exercise, Fig. 5.10.

5.4.5 *Profitability Index*

Another investment measure is the Profitability Index. This is defined as:

$$\text{Profitability Index} = \text{NPV of Earnings Net Investment/Investment} \quad (5.15)$$

The calculations are based on discounting at the MARR. For a project to be acceptable, its Profitability Index must be greater than 1. Competing projects can be ranked by their profitability index.

An example of a profitability index calculation is given in the solution to the Communications System Case Study Exercise, Fig. 5.11.

5.4.6 *Return on Investment (ROI)*

In the case of a specific project, the Return on Investment is the same as the Internal Rate of Return which we have already considered. When considering the activities of the organization as a whole—as opposed to individual projects—we define the return on investment as follows:

$$\text{ROI} = \text{Annual Operating Profit \$/Value of Operating Assets \$}. \quad (5.16)$$

Thus, for example, an organization with \$1 billion in operating assets and \$100 million in operating profit would have a ROI of 10 %.

5.4.7 Project Financial Measures—Summary

The following project financial measures have been outlined. Here we summarize some of their features. In practice, we may evaluate several of the measures to help us in our investment decisions.

- a. Net Present Value NPV: This is the only measure that indicates the size of a project. It does not give an indication of risk, but analyses can be carried out under different scenarios and at different interest rates as an aid to evaluating risk.
- b. Payback Period: Gives an indication of how soon we expect a project to be “in the black.” A short payback period is a highly desirable feature in an investment, as it is then less sensitive to risk and to revenue or costs estimates which can become inaccurate over time.
- c. Internal Rate of Return IRR: This is probably the most widely used measure. When compared with the Minimum Acceptable Rate of Return (MARR), it indicates whether a project is financially worthwhile and gives an indication of risk. A project with a high IRR is less vulnerable to risk.
- d. Profitability Index: Simpler in concept than the IRR, but plays the same role in estimating the financial viability of a project.

5.5 Exercises

5.5.1 Discounted Cash Flow Revision Question

Explain the following terms:

- a. Interest rate
- b. Present value
- c. Discount factor
- d. Net Present Value
- e. Cash flow diagram
- f. Equivalent Annual Cost
- g. Annuity factor
- h. Capital Recovery Factor
- i. Payback period
- j. Internal rate of return
- k. Minimum acceptable rate of return
- l. Profitability index

5.5.2 Materials Handling System—Net Present Value Exercise

A planned new materials handling system in a chemical plant has costs and returns which have been estimated as follows. The returns, or net benefits, are the savings made by the system, in comparison to an earlier less efficient system which it replaces. An interest rate of 5 % is to be assumed in this case.

- a. System purchase and installation at beginning of year 1 costs \$1,000,000.
- b. Additional costs associated with workflow changes and training in year 1, less benefits in year 1, amount to a net cost of \$200,000, considered effective at end of year (EOY).
- c. Net benefits in year 2 are \$500,000 (EOY) and thereafter \$750,000 pa (EOY).

5.5.2.1 Tasks and Questions

- a. Construct a cash flow diagram.
- b. Create a spreadsheet to determine the NPV of the project up to 5 years ahead.

5.5.3 Materials Handling System—Payback Period Exercise

A planned new materials handling system in a chemical plant has costs and returns which have been estimated as follows. An interest rate of 5 % is to be assumed in this case.

- d. System purchase and installation at beginning of year 1 costs \$1,000,000.
- e. Additional costs associated with workflow changes and training in year 1, less benefits in year 1, amount to a net cost of \$200,000, considered effective at end of year (EOY).
- f. Net benefits in year 2 are \$500,000 (EOY) and thereafter \$750,000 pa (EOY).

5.5.3.1 Tasks and Questions

Create a spreadsheet to estimate the payback period.
Comment on the suitability of the project in terms of the payback period.

5.5.4 Communications System Exercise

Purchase of a new communications system by a maintenance organization has been estimated to save money in travel time and staffing. The cost of the new

Table 5.1 Communications system estimated cost and savings

Year	0	1	2	3	4	5
Cash flow end of year	−\$2,500,000	\$500,000	\$750,000	\$900,000	\$900,000	\$900,000

system is \$2,500,000. The system will be used over a 5-year period in which the expected savings year by year are as shown in Table 5.1.

Tasks and questions:

- Create a spreadsheet to calculate the Internal Rate of Return.
- The Minimum Acceptable Rate of return for projects used as a company guideline is 15 %. Does this project meet the guideline requirements?
- What is the Profitability Index for the Communications System?
- Would you recommend that the investment in the communications system should proceed?

5.6 Financial Analysis of a Turbo-Generator Project—Exercise

An electric power generation company can install a small gas turbine-powered generator at an initial cost of \$15 million, to provide peak load power. The revenue from the sale of electricity from this plant, and the corresponding expenses have been estimated, on an End of Year basis, as shown in the following data table.

Year	Revenue (\$Million)	Expense (\$Million)
1	12	5
2	12	5
3	13	6
4	13	7
5	14	8

The Minimum Acceptable Rate of Return used by the company is 15 %. Calculate the following.

- a. The NPV of the project over 5 years at a cost of capital of 8 % (\$11.53 million)
- b. The payback period (3 years).
- c. Show that the internal rate of return over 5 years is approximately 35 %.
- d. What is the value of the project to the company, over and above the minimum acceptable return (\$7.40 million).

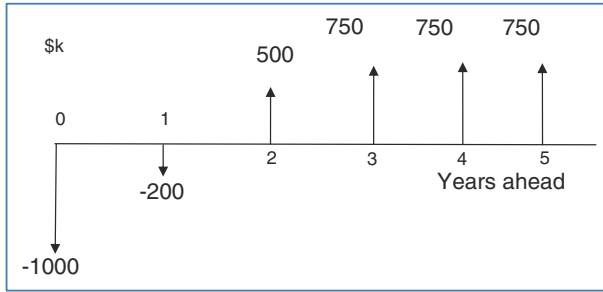

Fig. 5.7 Materials handling system cash flow

5.6.1 Materials Handling System—Net Present Value Solution

5.6.1.1 Cash Flow Diagram

The cash flow diagram is shown in Fig. 5.7.

5.6.1.2 Net Present Value

The calculation of the NPV generated by the materials handling system over a 5 year horizon is shown in Fig. 5.8, using the Excel NPV function. The result is an NPV of \$1,115,588 shown at cell G4. This is the net benefit generated by the new system over the 5 year period.

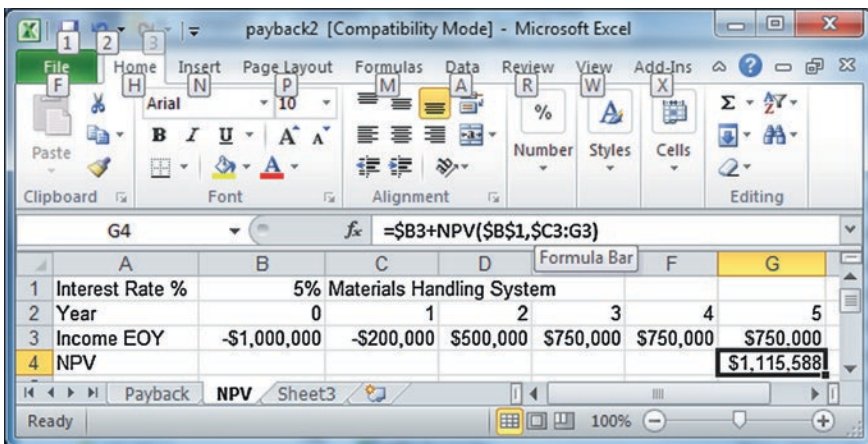

Fig. 5.8 Net present value of materials handling system

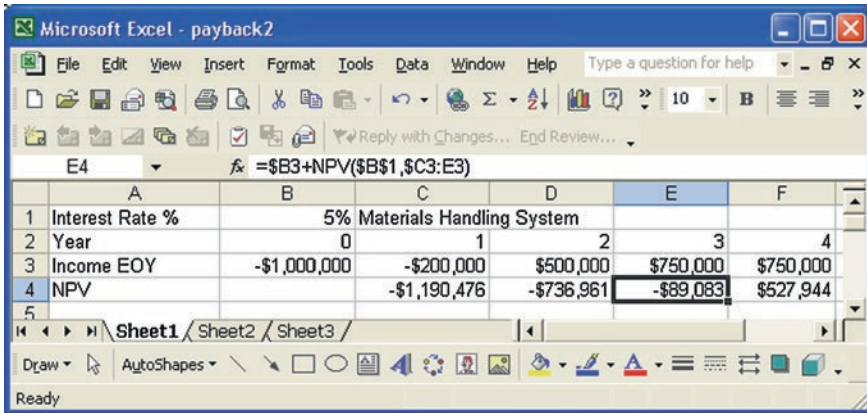

Fig. 5.9 Materials handling payback period calculation

5.6.2 Materials Handling System Payback Period—Solution

To determine the payback period, we calculate the cumulative NPV of the investment plus its related returns, working forward year by year until a positive value is obtained. Figure 5.9 shows the calculation of the NPV of the investment plus returns working forward year by year. The financial data are in row 3, and row 4 shows the NPV of the cumulative returns up to years 1, 2, 3, and 4.

As an example of the calculation, the formula field shows the formula used to calculate the returns up to end of year 3. This is given by the initial investment, from cell B3, plus the NPV of the returns from end of year 1 to end of year 3, from cells C3:E3. The result for year 3 is $-\$89,083$, showing that we have not fully recouped the investment by the end of year 3. However, for year 4 we get a positive value of $\$527,944$, shown in cell F4. Hence we see that the payback period for this investment is a little over 3 years.

The project appears worthwhile as the payback period is reasonably short and the benefits may continue for some time ahead. However, there is always the possibility of further technical developments in a time frame of 5 years plus.

5.6.3 Communications System Solution

Figure 5.10 shows the calculation of the IRR using Excel. The investment amount of $\$2,500,000$ is in cell B3 and the expected savings are in cells C3–G3. Cell B4 shows the IRR which is 15.85%. The IRR function is shown in the function field.

In this example the IRR is 15.85%, so that, at a MARR of 15%, the project is just acceptable.

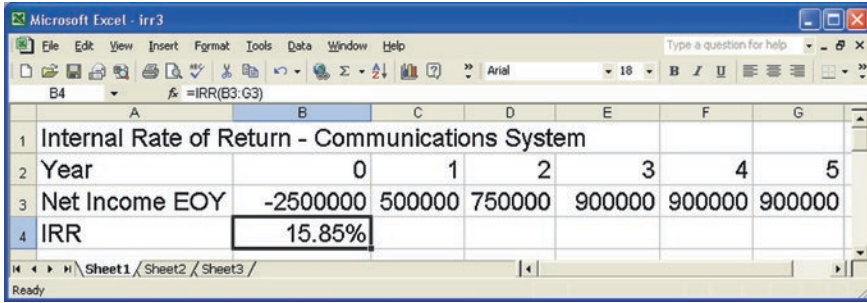

Fig. 5.10 Communication system IRR using excel function

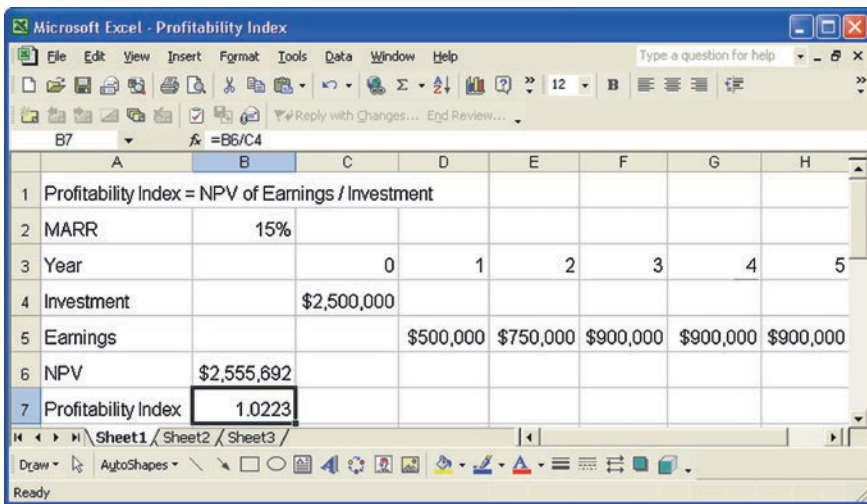

Fig. 5.11 Profitability index

Figure 5.11 shows the calculation of the Profitability Index. The investment of \$2,500,000 is at C4, the returns are at D5–H5. The NPV of the returns is calculated at B6 using the NPV function and the MARR interest rate. The Profitability Index is calculated at B7 and is given by B6/C4. The Profitability Index is slightly greater than 1, which we expect as the IRR is slightly greater than the MARR. In practice, this project may be displaced by others with a higher profitability index.

5.6.4 Financial Analysis of Turbo-Generator Exercise Solution

	A	B	C	D	E	F	G
1	Pay Back Period		PBKdesk.xls		Power Station		
2	Year	0	1	2	3	4	5
3	Interest rate %	8					
4	Discount factors	1	0.9259	0.8573	0.7938	0.7350	0.6806
5	Revenue	0	12	12	13	13	14
6	Expense	15	5	5	6	7	8
7	Net Income EOY	-15	7	7	7	6	6
8	PV of Net Income		\$6.48	\$6.00	\$5.56	\$4.41	\$4.08
9	Cumul NPV		(\$8.52)	(\$2.52)	\$3.04	\$7.45	\$11.53
10	IRR using Excel function						35.060%
11	Interest Rate %	15					
12	Discount factors	1	0.8696	0.7561	0.6575	0.5718	0.4972
13	Revenue	0	12	12	13	13	14
14	Expense	15	5	5	6	7	8
15	Net Income EOY	-15	7	7	7	6	6
16	PV of Net Income		\$6.09	\$5.29	\$4.60	\$3.43	\$2.98
17	Cumul NPV		(\$8.91)	(\$3.62)	\$0.98	\$4.41	\$7.40

Chapter 6

Developing a Business Case

Abstract The aim of this chapter is to outline the principle steps involved in developing a business case. Asset managers are frequently involved in developing business cases which may range from the level of major capital projects to process improvements or system changes. Business cases are also required for activities such as outsourcing. This chapter is concerned with the overall structure outline content of business cases. *Outcomes* After reading this chapter you will know what steps to take in order to develop a business case. You will have available a list of headings under which a business case can be developed, for both large and small projects. You will have enjoyed reading about the use of business case methods to choose a bottle of wine in a restaurant.

6.1 Business Case Introduction¹

A business case is an argument for taking a particular acquisition or development path. It involves defining the proposed path and stating the reasons for and against pursuing that path, in terms of revenue, costs, discounted cash flow criteria, benefits, and risks. Development of a business case is an essential activity which arises at several stages in the asset development process. Asset management personnel need to be familiar with the steps involved in developing a business case, and to be skilled in developing and presenting cases. It is also important to undertake this task objectively, so that the business advantages and disadvantages of any particular case are presented in a balanced way, without undue bias or emotional commitment.

The ability to develop and present a well-argued business case is a key attribute of a good asset manager. Lack of ability to develop and present a business case indicates a lack of maturity in the asset management role.

¹ Relevant areas of the standards are ISO 55001 Clause 6.2.2 and ISO 55002 Clauses 6.2.1.3 and 6.2.2.1.

Good management will take many factors into account when assessing a proposal, but it is important to recognize that the focus of senior management will certainly include:

- Profit,
- Accountability, and
- Business strategy.

Practitioners are often more focused on:

- Equipment availability,
- Maintenance,
- Logistics,
- Risks,
- Continuity, and
- Technology.

The asset management role involves bridging the gap, giving the best outcome for the organization as a whole. In particular it should be recognized that any particular project may have merits, but is likely to be in financial competition with others.

It is therefore essential to bring financial considerations to bear and to express these in standard terms such as Return on Investment and Net Present Value in order to establish the case in the minds of senior management.

6.2 Development Plan

Before a business case can be developed it is essential to create the plan on which it is to be based. In the case of a major project development, based on the procedure outlined in the previous chapter, project planning and business case development proceed hand-in-hand. Thus, the prefeasibility analysis phase will lead to the development of an initial business case. If this is approved the project will enter the feasibility analysis phase which will lead to the development of the final business case, and if this is approved the project will proceed to the acquisition/development stage.

Besides the formal development of business cases for major projects, we will often want to develop business cases in a wide range of situations. The evaluation of options for practically any development can be assisted by the development of an initial business case. For minor projects the two stage process used in major developments may still be followed in principle, but only one actual business case will normally be created, and less detail will be required.

6.3 Business Case Outline

An asset development plan contains information from which we develop a business case. The business case is a summary of the plan, put forward for approval and funding. In outline it covers the following points:

- (1) Project title, name of proposing group, name and details of contact person(s)
- (2) Executive summary
 - (i) Brief statement of problem or opportunity
 - (ii) Aim of proposal, expected function or effect, and main benefits
 - (iii) Financial summary, revenue, costs, and NPV projected
 - (iv) Risks
- (3) Background situation
 - (i) An objective statement of current strengths, weaknesses, opportunities, and threats
 - (ii) Development concept
 - (iii) Asset needs analysis
 - (iv) Existing capability, planned capability, and capability gap analysis
 - (v) Indication of any important relationships to other capabilities or proposals
- (4) Stakeholders—list the roles and/or individuals impacted by the proposal
- (5) Planning assumptions such as
 - (i) Level of service required
 - (ii) Availability of relevant items, e.g., equipment, land, and utilities
 - (iii) Demand assumptions
 - (iv) Price assumptions
- (6) Options available
 - (i) Include “do nothing” or “base case” option
 - (ii) For each option summarize relevant concept, data, and analysis
 - (iii) Include consequences if no action taken
 - (iv) Indication of preferred option with reasons
- (7) Preferred option description
 - (i) Operational concept, function, effects, and net benefits
 - (ii) Technical feasibility
 - (iii) Function and performance specifications
 - (iv) Acquisition strategy
 - (v) Financial summary
 - (vi) Consider wider impacts

- (8) Project financial analysis for preferred option
 - (i) Added revenue, value, and/or cost savings
 - (ii) Acquisition and development costs
 - (iii) Net personnel and operating costs or savings
 - (iv) Logistic support and through life costs, LCC
 - (v) Project implementation costs
 - (vi) Required budget
 - (vii) Cash flow analysis
 - (viii) Investment analysis: Payback Period
 - (ix) Investment analysis, NPV, IRR (indicate planning horizon)
- (9) Semiquantifiable benefits. Estimate physical values, e.g., extra tonnes produced, reduction in losses. Possibly estimate \$ value but state basis of calculation so that management judgement can be applied. Benefits may include:
 - (i) Increased reliability and availability
 - (ii) Reduced production loss
 - (iii) Asset life extension
- (10) Human resource factors, availability, net cost, and training
- (11) Environmental assessment
 - (i) Environmental protection actions required, such as sound barriers and waste disposal facilities
 - (ii) Environmental benefits and regulatory requirements met
- (12) Health and safety assessment and requirements or issues
- (13) Nonfinancial benefits
 - (i) Identify benefits of a nonfinancial nature such as social services, sports ground development,...
- (14) Summary of project activities
 - (i) Acquisition/Development strategy
 - (ii) Scope of Work
 - (iii) Timings, Project lead time
 - (iv) Business continuity plan during implementation
 - (v) Sustainability aspects
- (15) Risk analysis
 - (i) Identify risks of doing nothing
 - (ii) Identify risks to the project succeeding, solution risk, schedule risk, and financial risk. May include high, medium, and low analysis
 - (iii) Identify risks in the longer term
- (16) Development project management
 - (i) Indicate the resources and funds required to manage the implementation of the plan

- (17) Performance monitoring
 - (i) Indicate how the intended results will be monitored and reported
 - (ii) Identify the key measure of success
- (18) Proposed date of decision
- (19) Proposed in-service date
- (20) Concluding summary.

6.4 Smaller Project Business Case Outline

For a smaller project a brief case will cover the following points:

- (1) Name of Proposer
- (2) Title of Project
- (3) Executive summary, physical, and financial
- (4) Introduction and background
- (5) Current situation
- (6) Forecasts and opportunities
- (7) Stakeholders impacted by the proposal
- (8) Desired future state
- (9) Outline of options including maintain status quo and potential development paths
- (10) Proposed development, acquisitions, and scope of work
- (11) Physical/material business benefits, e.g., more production quantity, less losses, staffing, or resource savings
- (12) Estimated value NPV, Payback Period, and IRR
- (13) Identify the key measure of success
- (14) Risk, environmental, and health and safety considerations
- (15) Proposed timings including in-service date.

6.5 Impact of Downtime

When a machine breaks down, there is usually a loss of production or service, as well as repair costs, and little or no saving on other costs of doing business. Many projects involve a justification based on reductions in actual or potential downtime.

The impact of downtime can vary widely depending on circumstances. In making out a business case for an asset-based acquisition or improvement, it is desirable to address the issues associated with the impact of downtime or other service losses which may occur if the project is not pursued. The following are some types of cost arising from downtime:

Loss of production which cannot be made up In this case, sales of the product are lost and the corresponding revenue is lost. The cost of downtime is the cost of

the lost sales minus unused consumables. This applies to every machine for which downtime results in irrecoverable loss of production. Machines which impact fully on lost revenue are referred to as *bottleneck* machines. Asset improvement efforts are often directed at relieving bottlenecks, with the idea of improving throughput and reducing vulnerability of revenue to failures at the bottleneck.

Recoverable production loss Machine downtime may cause a production loss which can be made up by overtime working, subcontracting, outside purchasing, etc. When the machine is down, some costs may be saved, e.g., power and other consumables. But the cost of idle labor is often not recoverable. In this case the cost of downtime is the extra cost of running the machine in overtime. For subcontracting it is the cost of the subcontract minus the saving of unused consumables. For outside purchase it is the outside purchase cost minus unused consumables.

Contractual financial loss Failure to deliver the product on time may result in financial loss as part of a contract undertaking. Alternative product may need to be bought in from more expensive sources.

Loss of goodwill This may result in lost sales in the future and may have negative political impacts.

Spare capacity To reduce the impact of machine downtime we may introduce spare capacity. For example, a company operates a fleet of four-wheel-drive vehicles to support its operations. In normal operation, 80 vehicles are required to be available. The company has a fleet of 90 vehicles, providing a repair pool to cover breakdowns and routine maintenance. The provision of this spare capacity is a cost. If breakdowns occur to the extent that there are production losses, this is an additional to the cost of providing spare capacity.

Continuing with the vehicle fleet example, if the condition of the fleet deteriorates to an extent that less than 80 vehicles are available, and this impacts on production, then we need to address this by changes such as replacing older vehicles, increasing the size of the repair pool, or improving operating or maintenance practices. The justification for a project to make these changes would involve identifying the impact on the business of the loss of availability of the vehicles.

6.5.1 Physical or Service Losses

It is often easier to identify physical or service losses than it is to put an accurate cost on them. The reduction of losses may well be worthwhile even though we cannot cost them accurately. In making out a business case we should estimate the savings in physical or service terms, even if the precise financial effect is hard to quantify. Financial and operations' managers can make their own assessments of the impact of physical losses, and this may vary with the state of the market, levels of stockpiles, and so on.

For example, an ore loader moves approximately 5,000 tonnes of ore per day. If the loader is down for a day, 5,000 tonnes of production will be lost. This is the physical loss rate from loader downtime. If the typical sales price of the minerals yielded by a tonne of ore is \$100 then the loss of 5,000 tonnes amounts to \$500,000 in lost revenue. This is a figure which can be given in the business case, but the basis for calculation should always be given. Including the physical loss rate in a business case will provide information on which management can make its own financial judgement based on the perceived value of this production loss.

In a general business setting, the term Price of Non-Conformance (PONC) is used to describe the costs involved in any deviation from correct processes.

6.5.2 Cost of Failure

Figure 6.1 lists some of the cost factors which can arise when a failure occurs.

6.5.3 Indicate Savings and Returns on Investment

Always give a financial estimate of the value of your proposal and the basis on which it is calculated. For a proposal which will improve reliability, provide forecasts of the reduction in the numbers of failures and hence in the costs of downtime, repairs, spares, and lost production. Provide historical or comparative data where possible.

Fig. 6.1 Cost factors of failure

Production or Service <ul style="list-style-type: none"> • lost sales through downtime, and wind-down and start-up of related areas • contractual loss • goodwill loss • rework Primary Repair Cost <ul style="list-style-type: none"> • labour • overhead • spares Secondary Repair Cost <ul style="list-style-type: none"> • labour • overhead • spares 	Safety/Health <ul style="list-style-type: none"> • lost time • trauma • workers compensation and insurance Environment <ul style="list-style-type: none"> • clean up • corrective • legal costs • legal liabilities
-----------------------------------------------------------------------------------------------------------------------------------------------------------------------------------------------------------------------------------------------------------------------------------------------------------------------------------------------------------------------------------------------------------------------------------------------------------------------	------------------------------------------------------------------------------------------------------------------------------------------------------------------------------------------------------------------------------------------------------------------------------------------------

For a proposal which will reduce downtime, estimate the reduction in production or service losses and estimate the value to the organization. This will offset any additional expenditure on maintenance personnel or equipment.

Liaise with accounting personnel on getting the financial implications correct and in regard to the timing of submissions.

Indicate trends, e.g., increasing demand, aging equipment, replacement requirements, changes in costs, and the financial implications of these factors.

6.6 The Final Decision to Proceed

The final decision to proceed lies with senior management. It will be based on financial considerations, combined with judgement in relation to forecasts of future developments, consideration of future flexibility and of risks to both the project itself and to the assumptions underlying the business case. Health, safety, and regulatory factors will be considered.

6.7 Approved Development Plan

Once approved, a project becomes part of the organization's approved Business Development Plan. This is a portfolio maintained by the organization, which contains all project plans which have received final approval but are not yet introduced into service.

Projects in the approved Business Development Plan must be taken into account in subsequent planning, and will be regarded as fixed, unless changes are approved at senior level. Such changes should only be made in response to significant changes in the business environment.

6.8 Wine Selection Example

Some fundamentals of the entire business development process can be illustrated by means of the following example relating to the purchase of wine in a restaurant.

Problem Statement

To meet the drinking requirements of the party

Stakeholder group: All members of the party

Options: Beer, Wine (white or red?), and Water

Needs analysis: We need 2 bottles of red wine, 1 bottle of white, and some water.

Capability Gap Analysis

Needed = 2 red, 1 white, and water

Available = 1 bottle of white brought by a member of the party. Water is available in restaurant at no cost.

Gap = 2 bottles of red wine.

Capability Requirements Statement

We require 2 bottles of red wine.

Decision Criteria

A next step is to establish the criteria on which we are going to make our decision. For wine selection we may decide that our criteria are:

- Produced in South Australia (or other region preferred by top management)
- Made from one grape variety—no cheap blends
- At least 2 years old—no vintage-Thursday-week stuff
- At least 14 % alcohol—we are serious
- Within notional budget—but not rash.

Prefeasibility analysis

Acquisition strategies were identified as:

- Buy from the restaurant wine list
- Buy from the bottle shop down the road.

Check against criteria—was there wine on the list that met them. Answer, Yes there were three. Options analysis involved ranking them in order of price. One wine was deemed too expensive and so it was eliminated.

Stakeholder group meeting

No one wanted to go out to the bottle shop.

White wine drinkers now say that one bottle may not be enough.

Prefeasibility proposal

Buy the middle priced red wine from the restaurant list—the cheapest wine was considered too high a quality risk. White wine drinkers are to buy extra by the glass if needed. It was noted that this extra white wine requirement should have been identified at the needs analysis stage. A possible issue was whether white wine drinkers should pay separately for extras, but this was countered by the fact that the bottle of white was provided by a member of the party. The prefeasibility proposal was approved.

Feasibility analysis

Check current availability of selected wine with waiter. Confirm that the price is as on list.

Test and Evaluation

Sample the wine and continue with the current plan only if the wine is satisfactory.

Project approval

Wine approved. Place order for selected wine. Wine ordered.

Implementation

Wine delivered, drunk, and empty bottles disposed of thoughtfully.

Note: For the white wine, through life logistic support was required in the form of an ice bucket and ice, or other temperature maintaining device.

6.9 Exercises

6.9.1 Organizational Structure and Procedures

Check out the organizational structure for asset management within your own organization. Identify any documented procedures for asset management aspects of business planning, expenditure proposals, and acquisition projects.

6.9.2 Own Project

Develop, and present a plan and business case for an asset management development in your organization or similar. The report may represent a project proposal or may extend into implementation and assessment of results. The scale of this and the degree of detail may vary depending on the type of development, which can be a minor improvement proposal or a more significant acquisition or development.

Typical features to be contained in your report are shown in the Business Case Outline in Sect. 6.3. However, the range of items and level of detail covered in your report should reflect the actual range and relevance of the activity in your project. For smaller projects use the Smaller Business Case Outline from Sect. 6.4.

6.9.3 Pacific Earth Moving Part 2

Pacific Earth Moving is a medium-sized company which sells, maintains, and hires out excavators, bulldozers, graders, trucks, and other earth moving equipment. Increased demand is occurring for the company's services and the company needs to develop proposals which will enable it to fund and implement expansion. Several existing senior managers have recently retired and a new organizational approach is needed to plan and implement developments.

You have been hired to advise Pacific Earth Moving on establishing a systematic approach to its future. What factors should the organization consider in deciding on the overall direction and pace of development? What analysis should be undertaken prior to commencing equipment acquisition? Give your answers in dot point form.

6.10 Experience Required

Jock applied for the position of Project Manager for the prefeasibility study for an expansion at the Sandy Point plant. He was doubtful of his chances of getting the job, but was disappointed to find that he was not even short-listed. Rumor had it that the front runner was an experienced project manager from Sydney, but a counter rumor said that this guy was fishing for an even bigger job. There were also four or five others who had made the short list.

Jock and Sheila continued house hunting and Jock continued worrying about money. Sheila gave up work.

“I have more important priorities now,” she said.

Jock looked out for other job options, but nothing came up. Then out of the blue he had a call from the Human Resource Manager. She said that Ricardo wanted to see him. Ricardo was the CEO and he had only met him once before. That time he had made the mistake of calling him “Mr. Ricardo”, not realizing that Ricardo was his first name. Ricardo was only a Divisional Manager then and less well known, but still it was an embarrassing moment.

Jock’s meeting with Ricardo went surprisingly well. Ricardo wanted him to run the Sandy Point project!

“Yes Mr. Mello,” said Jock.

“Call me Ricardo,” said Ricardo and they both laughed.

Jock was mystified how he had got the job, but his friend Declan from corporate legal said it must have been to do with the bitumen plant. It was after a budget meeting at the bitumen plant that Jock had met Ricardo the first time.

“Yes, maybe,” said Jock to Declan. “I was lumbered with the job of Acting Operations Manager at the bitumen plant when some guy went sick. That was when I realized the meaning of the phrase ‘Asset Death Spiral’. The funny thing was that the plant was running above nameplate output and bitumen was selling like hot bitumen.”

“No wonder the financial boys were happy,” said Declan, “It was the classic ageing cash cow.”

“But nothing happened,” said Jock, “My budget was approved.”

“I was at that meeting,” said Declan, “And it may have seemed like nothing to you but after you left there was a massive argument. The Divisional Financial guy said that your budget proposals for CAPEX and OPEX had no business justification and were just waffly ambit claims. But my boss spoke up for you. It was the first time that I had heard him speak up on anything. It was those photos that you showed at the end of your presentation—the ones with the leaking drums.”

“I wasn’t sure if I should show those,” said Jock, “It could have been a CLM.”

“CLM?” said Declan.

“Career Limiting Move. I held back the worst ones just in case,” said Jock.

“Well, anyway,” said Declan, “My boss said that if any of that stuff leaked into the creek, and it got out that they had knocked back your budget proposal then it would look bad in court. When he said “in court” Ricardo really picked up on it. The argument went on, but Ricardo eventually said that he took it that nobody was opposed to the budget submission, and by that time, nobody was.”

Later Jock caught up with the HR manager to fix up some details. He could not resist asking how it came about that he got the job when he was not short-listed. She was cagey—she had done the short-listing.

“Ricardo looked through all the applicants and said he wanted someone with in-plant experience,” she said, turning away.

Jock had not worked at Sandy Point, but had had 3 years at Jungalup. “Those other applicants certainly weren’t Desert Rats, more like Gabardine Swine,” he mused, with one of his Pop’s old phrases coming into play.

That evening Sheila had more news—she had found a house. No, she did not care about Jock’s stupid decision criteria, the point was that she liked it. Jock looked at the Real Estate Agent’s brochure and it seemed that it actually met all his stupid criteria except one—it was \$150,000 over budget. Jock looked at her.

“Okay,” he said. Sheila gave him a hug.

The next day at work Jock worried about what Declan had told him about the inadequacy of his budget proposals at the bitumen plant. If he was going to make a success of the prefeasibility project then he would have to get a grip on the business of creating business cases. And he did not want to go asking the Gabardine Swine.

“I need to make some notes on business case development,” said Jock to himself.

6.11 Exercise Solution

6.11.1 *Pacific Earth Moving Part 2 Solution*

- Forecast of demand
- Forecast of revenue
- Asset gap analysis in relation to existing fleets
- Assessment of quantities and types of equipment needed
- Consideration of commercial competitors
- Proposed volumes and timing of acquisitions
- Identification of prospective suppliers and options, e.g., purchase and leasing
- Identification of logistic support requirements and costs
- Financial analysis including sources and cost of funds, return on investment
- Projected Cash Flow, Profit and Loss, and Balance Sheet calculations
- Risk analysis including optimistic, average, and pessimistic scenarios
- Acquisition approval.

Chapter 7

Implementing Development Plans

Success has many fathers, failure is an orphan.

Abstract To present the steps involved in implementing an asset acquisition or development plan from project approval to introduction into service. *Outcomes* After reading this chapter, you will be aware of the steps required to implement an asset acquisition or development plan. You will gain an overall perspective of the steps and activities involved in the implementation of asset development, from the establishment of a project team, through acquisition to commissioning, introduction into service, and change management. This will assist you in managing or participating in asset development.

7.1 Asset Development Portfolios¹

At any given point in time there will be many assets in service and many asset development projects at various stages. We shall use the term “portfolio” to mean a set of projects and/or their associated assets. The assets are grouped into several portfolios which correspond to their stage in the life cycle. These portfolios are labeled as follows:

- Requirements Portfolio
- Planning Portfolio
- Implementation Portfolio
- In-Service Assets
- Disposal Portfolio

We shall consider these portfolios as we discuss the development and lifecycle processes. Figure 7.1 shows the portfolios which assets go through over their lifetime. It is important to recognize that, although we may initially think of the life

¹ ISO 55001 Clause 8.1 Operational planning and control: “*The organization shall ...implement processes...to implement the...asset management plans...*”.

Fig. 7.1 Asset and project portfolios

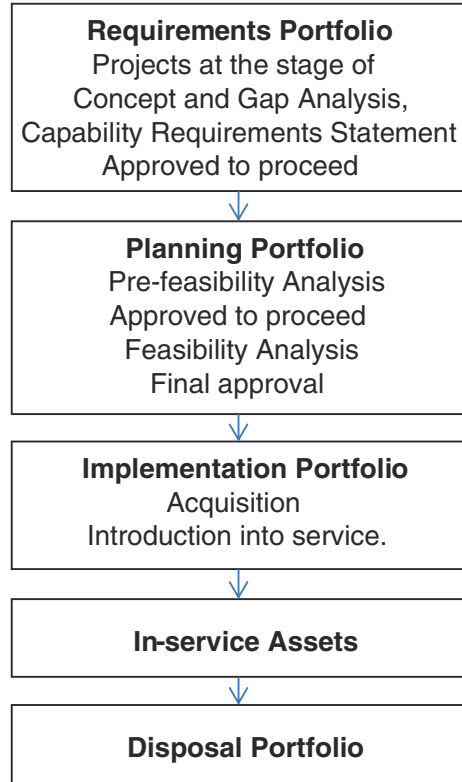

cycle of particular assets, the asset manager is concerned with a whole range of assets, and that at any one time, different assets are at different stages in their lives.

7.1.1 Requirements Portfolio

The *Requirements Portfolio* consists of projects which are in the concept or gap analysis stages and are working toward the capability requirements statement. They are not yet approved for detailed planning. When the capability requirements statement is complete, management will decide if a project is to go forward. If so, the project will move out of the requirements portfolio and go into the planning portfolio.

7.1.2 Planning Portfolio

The planning portfolio contains projects which are being planned. In the case of a major development, these plans are developed in two stages, referred to as

Pre-feasibility Analysis and Feasibility Analysis. In practice, the level of formality in moving through the planning process will depend on the complexity or otherwise of the project and the timing requirements of the development. However, the basic logic of the process is valid, even when some steps are accelerated. When planning is complete, management will decide if a project is to go forward. If so, the project will move out of the planning portfolio and into the implementation portfolio.

7.1.3 Implementation Portfolio

The implementation portfolio consists of projects which are being implemented. This involves the acquisition and implementation of the capability and its introduction into service.

7.1.4 In-Service Assets

These are the assets which are currently in-service, being used in operations and which require maintenance and logistic support.

7.1.5 Disposal Portfolio

These are the assets which are in the process of being disposed of.

7.2 Project Team and Activities

The requirements and planning stages of business development projects were considered in earlier chapters. The phases of capability requirements analysis, pre-feasibility analysis, and feasibility analysis establish the need, the asset requirements, the project plan, and the business case covering all aspects of the capability and its logistic support. A project budget will have been prepared and approved. The next step is to carry out the acquisition or development.

7.2.1 Team Functions

For a major development, a project team is established and a development project schedule is prepared. The project team will address the following roles, the number of persons involved being dependent on the size of the project. Some roles may be shared across projects, depending on the volume of work involved.

- Project Manager
- Assistant Project Managers for major subsidiary areas, geographically or technically, e.g., mechanical systems, electrical systems, instrumentation systems, and site construction
- Logistic support manager
- Scheduler
- Commercial manager
- Contracts manager
- Technical and administrative personnel supporting the above as required by the volume of work.

The members of the project team may be a dedicated business developmental group, may be sourced from relevant operational areas, or from asset management. In many cases, the asset management group will be either in a full project management role, or providing a major part of the development team.

7.2.2 Project Management

The implementation of development plans has three main stages, first the creation and letting of contracts for acquisition, development, and/or construction, second, the implementation of the defined work, and third, introduction into service of the new capability. A standard project management or work management software tool should be adopted as an aid to managing any large project. Planning and control is required for:

- Activities
- Resources
- Resource allocation
- Critical path
- Acquisition procedure
- Progress reporting

If the resources being used for a project overlap with those used for maintenance work, then it is desirable to manage all the activities in the one database.

7.2.3 Activities

The range of activities will typically include the following:

- a. Create a Project Management Plan for the development, including a list of activities and a schedule
- b. Create a functional specification document and selection criteria for tendering against
- c. Incorporate through life support requirements

- d. Create an Invitation to Register Interest if required
- e. Create request for tender document
- f. Tender evaluation and supplier selection process
- g. Pre-contract testing and evaluation against specifications
- h. Contract negotiation and agreement
- i. Acquisition
- j. Management of assets under construction
- k. Quality assurance
- l. Implement logistic support plan
- m. Installation
- n. Commissioning
- o. Pre-acceptance checks
- p. Equipment acceptance
- q. Implement training plan starting with train-the-trainer
- r. Operations and maintenance personnel to be trained and deployed
- s. Introduction into service
- t. Disposal of replaced equipment.

7.3 Project Milestones

Stages in a project can be identified by milestones such as the following:

- a. Requirements defined
- b. Design or acquisition specification complete
- c. Tendering complete
- d. Pre-contract testing and evaluation complete
- e. Contract let
- f. Installation complete
- g. Commissioning complete
- h. Pre-acceptance testing complete
- i. Final acceptance
- j. Operational.

7.4 Reliability Centered Procurement

Reliability Centered Procurement is the concept of considering the long-term reliability and sustainability of equipment at the procurement stage. It involves making decisions which make it easy to subsequently maintain and sustain the equipment, and to ensure that it is reliable both initially and through life. It involves giving weight to the selection of equipment which is known to be reliable and maintainable and for which logistic support is most readily delivered. In

practice, this often means selecting equipment which is available *off-the-shelf* and which is common use already. It involves checking for reliability and satisfactory installation at the time of acquisition. Key factors are equipment commonality, reliability, and maintainability appraisal, and acceptance testing.

7.4.1 Equipment Commonality

Commonality of equipment and systems helps to ensure a minimum of problems in operation and support. Commonality facilitates the achievement of high standards of productivity, reliability, and availability, by avoiding unnecessary operational and logistic problems. It involves applying the following principles:

- a. Keep to common equipment and to common systems across all sections of the organization. This minimizes diversity in operation, training, and maintenance, reduces total spares requirement by type and quantity; minimizes demands for tools, test equipment, range of know-how, and facilitates cannibalization.
- b. There can be negative aspects in reducing the diversity of systems to an absolute minimum. If a significant fault occurs it will affect all items, although there is then a counter argument that this will mean a rapid focus on solving the problem. It can also mean that the user is committed to just one supplier who may exploit this as a commercial advantage. A compromise is to use two suppliers, striking a balance between the benefits of reduced diversity and supplier competition.
- c. Purchase items which are of a type widely used in the community—operational and maintenance skills and spares will be available and relatively cheap.
- d. Purchase items locally manufactured (if any), assembled, or widely supported—operational and maintenance skills and spares will be available and relatively cheap.

7.4.2 Performance Standards

Consider performance standards in the following areas:

- a. Functional performance
- b. Operability
- c. Reliability
- d. Maintainability
- e. Logistic supportability
- f. Compatibility with, and integration with, related systems
- g. Health, safety, and environmental factors.

Resist political or prestige purchases where possible.

7.4.3 Test and Evaluation Criteria

Test and evaluation criteria are required in order to ensure that equipments perform to a sufficient standard to deliver the required capability. At the preacquisition stage, relevant standards and tests should be specified and a test and evaluation management plan should be created. Ideally, some testing of items should take place early, so that a realistic appreciation of expectations of equipment can be formed, and test criteria specified in the contract phase. Equipment is usually specified to prescribed standards such as ISO, BS, DIN, or EN.

7.4.4 Preferred Suppliers

The principles just outlined, particularly regarding commonality, may conflict with the requirements of open tendering. A compromise position can involve the use of preferred (or accredited) suppliers, whose technical and logistic support credentials have been established in advance.

Suppliers are invited to prequalify as accredited suppliers. A panel is established which determines the range and quality of equipment which a given supplier can provide, the extent and location of logistic support, and the ability to work with users to meet needs over a period of time. It is important to allow for new entrants and business transparency. The market generally should be kept informed of needs and be allowed to respond to developments and requirements as technologies evolve.

Where several manufacturers produce to an established international standard, it can be difficult to distinguish between suppliers. Life cycle costing provides a basis for taking into account factors beyond the initial acquisition cost. However, the operating expenses in the life cycle cost are often a less firm than the initial capital costs. Ultimately, a tender selection problem remains to be resolved by a combination of performance, cost, logistic support analysis, and judgment.

7.5 Evaluation of Suppliers

Before committing to a supplier, assess the potential ability of the supplier to deliver the proposed capability. This will involve assessing technical and managerial competence, financial viability, track record, and future potential. There is a tendency to play safe and prefer larger organizations to smaller ones. Look particularly at the competence of a supplier in close relation to the specific capability which is sought. One supplier may match your need well, whereas another supplier may be relying on ambit claims of competence which do not include the specific area required by the current project.

7.6 Equipment Selection and Trials and Acceptance

Formal tests should be organized as part of the acquisition process, both in deciding on the acquisition and in verifying the equipment selected. The results obtained in the application of the test and evaluation plan should form key milestones in the subsequent acquisition process.

- a. Carry out a formal appraisal of operations, reliability, and maintainability. This will involve setting up a trial in order to check that equipment performance is up to expectations in terms of operating, reliability and maintainability criteria. For equipment with design features special to your application, a Reliability Centered Maintenance approach should be adopted, reviewing equipment functions, potential failure modes, potential effects of failure including safety and environmental effects, and related maintenance or inspection tasks.
- b. In assessing a new type of equipment, consider (and cost) the training and logistic support required.
- c. Ensure that products are in good condition and meet necessary specifications before acceptance.
- d. Pay attention to installation and set up.

Figure 7.2 shows a check list of points relating to equipment selection and acceptance.

Criterion	Option 1 Equipment Type A	Option 2 Equipment Type B
Performance in relation to specification		
Acquisition and life cycle cost assessment		
Compatibility with existing equipment and systems		
Operations considerations		
Site preparation, Facilities		
Maintenance considerations		
Documentation provision and standards		
Logistic support		
Overall rating		

Fig. 7.2 Equipment rating and selection summary

7.7 Through Life Support

Through Life Support provision involves implementing the logistic support plan, updated to reflect the actual equipment selection choices made in the acquisition process.

7.8 Financial and Contract Process

Figure 7.3 summarizes the steps to be taken.

7.9 Project Maturity Status

At any one time, a portfolio of implementation projects will be current. Figure 7.4 shows a scheme for describing the maturity status of these projects. As a project matures, its total maturity score will progress towards 25 and we can monitor progress and manage priorities by reference to the maturity score at any point.

7.10 Assigning Responsibilities

In any project or operational situation it is important that people understand what their responsibilities are. A convenient way of considering this for any given function is to consider who is *responsible* for carrying out the function, who is

Fig. 7.3 Capital project financial and contract stages

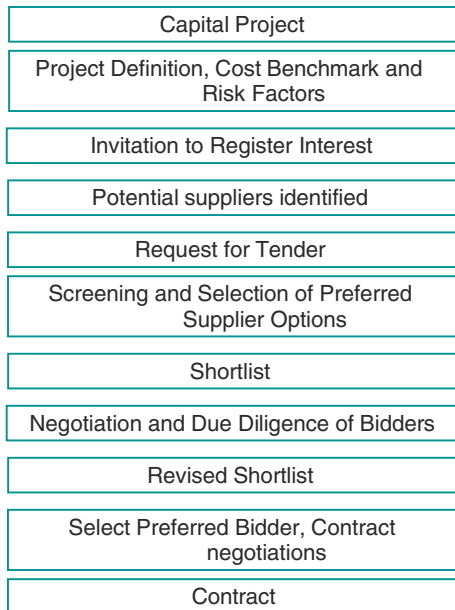

Maturity Score	Business Status	Technical Status	Cost	Schedule	Operations and Support
5	Achieved	Proven	Within Budget	Achieved	Operational
4	Demonstrated	Demonstrated	Within Contingency	Confident	Transitional
3	Acceptable	Integrated	Exceeds contingency	Acceptable	Developing
2	Contracted	Designed	Contracted	In tolerance	Being procured
1	Negotiating	Planned	Negotiating	Manageable	Defined

Fig. 7.4 Implementation project maturity scores

accountable for the results, who needs to be *consulted* about the activities and who needs to be *informed*. This is referred to as a RACI analysis.

A RACI chart is a chart in which the columns contain personnel functions and the rows contain activities. The cells contain one or more of the letters R, A, C, I indicating:

R = Responsible
A = Accountable
C = Consulted
I = Informed

Although this approach is described as RACI, in terms of seniority of roles, Accountable is the highest. Thus the technique is really better described as ARCI, but the abbreviation does not work out so well. The Accountable person has the overall responsibility (!), the Responsible person does the day to day management, the Consulted persons are drawn on for specific knowledge or expertise and the Informed persons are kept informed of progress.

Only one Accountable and one Responsible entry should appear in any row. Figure 7.5 shows an example relating to an equipment acquisition project. There

	Project Manager	Contracts Manager	Logistic Support Manager	Equipment User Representative
Meeting schedule and budget	RA	I	I	CI
Acquisition contract	A	R	I	I
Logistic support plan	A	C	R	I
Introduction into service	A	I	C	R

Fig. 7.5 RACI chart for acquisition project

should be a single point of overall accountability for the business deliverables in any project.

7.11 Project Management Reports

Standard reporting methods must be established for projects. Examples of types of reports are as follows:

7.11.1 Topics

- a. Financial overview report
 - i. Monthly
 - ii. Cumulative
 - iii. Forecast
- b. Project overview report; progress to date, forecast, and risks
- c. Recent activities and immediately forthcoming activities
- d. Logistic support and sustainment, overview report
- e. Capital budget progress reports
- f. Project summary report.

7.11.2 Financial Overview Report

The financial overview report contains information on the following points:

- Project total budget
- Project financial status in relation to planned milestones
- Actual expenditure to date
- Planned expenditure to date
- Planned future expenditure
- Budget remaining
- Budgetary status of risks remaining and retired
- Contingency used
- Contingency remaining.

7.12 Project Progress Monitoring

Once a capital project has been approved, it enters the implementation portfolio. Its progress is then tracked and monitored at project review meetings which are held regularly (weekly or monthly) and are attended by the relevant management team

members and stakeholders of the project. The regular meetings are to make sure that the projects keep progressing and any potential issues are identified and actioned.

For the portfolio of implementation projects, progress can be monitored with the help of a one-line progress report per project, indicating the status in respect to the following features. Traffic light symbols or smiley face symbols may be used to give a rapid visual summary of project status.

- physical progress relative to plan,
- financial status relative to budget,
- current problem severity,
- risk severity, and
- financial forecast.

Management should then drill down to more detail on under-performing features. As the project proceeds, monitoring should cover the following points.

- Executive summary
- Project background and aims
- Current overall project status
- Status in relation to in-service date
- Schedule progress issues—any activities delayed and their potential effect
- Budget status planned versus actual, budget projection, contingency used, and remaining
- Projected performance assessment of primary system
- Current and projected status of remaining items of the capability
- Stability of requirements
- Current feedback from stakeholders
- Performance and potential performance of the contractors/suppliers
- Report on resourcing of the development project
- Report on progress with logistic support plan
- Current issues summary
- Risks.

7.12.1 Delays and Overruns

Sometimes a project will hit a roadblock, that is, a major problem which, unless and until it is resolved, will prevent the project proceeding. For example, in a project to upgrade a load carrying vehicle, it was planned to install a larger engine than that used in the original version. However, tests showed that the new engine overheated when installed in the original layout and that major design revision was required. Unfortunately, the project manager, the stakeholders, and senior personnel in the organization continued to focus on schedules and budgets as though the engine overheating issue did not exist, or was about to be quickly resolved. In fact, the redesign problem was very challenging and a 2-year delay occurred. Money could have been saved by halting many activities while the engine heating problem was resolved.

Performance monitoring and solution risk are important aspects of project management that can easily be sidelined in the wealth of detail and the political commitment to schedules, budgets, and announcements. Project managers need to have the following questions firmly in mind in regard to technical performance issues:

- Does it work?
- Does it perform to specification?
- If not, can it possibly/probably be fixed—indicate risks
- If so, is there a reasonable plan to probably fix it?
- Is there an acceptable performance level if the fix does not work?
- Is there an acceptable performance level if the item does not meet the original specifications?
- Is there a contingency plan?
- Should we declare a formal delay?
- Should we abandon the project?

Sadly, these questions may be pushed under the carpet, until a multi-billion disaster occurs.

7.12.2 Scope Creep

Ideally, the scope of a project should not change once it has started. In reality, the world does not stand still, so that, while we should be generally resistant to changes in project scope, they may sometimes represent the best option for the organization as a whole.

Initial plans for a footbridge over the river in Brisbane were changed midstream to reduce the slope of the approaches and add a lift. This greatly improved the practicality of the bridge for cyclists and wheel chair users. At the time of these changes, the bridge was described in the media as being late and over-budget, but the final product was successful, very well patronized, and was built at reasonable cost in terms of what was actually delivered, though this was about twice the cost of the version that was originally planned. This positive example, however, is not intended to excuse scope creep in general.

7.12.3 Project Progress Report Examples

Examples of some graphically focussed project progress reports, based on a plant upgrade project, are shown in Figs. 7.6, 7.7, 7.8, and 7.9.

7.13 Project Portfolio Management

At any one time a number of projects will be active in the business development portfolios. In managing a portfolio, changes due to delays from many causes both internal and external are likely to occur. Occasional speeding up, cost overruns and scope

Factor	Performance to date	Forecast	Comments
Physical capabilities	☹	☹	Satisfactory progress in achieving planned activities to date – mainly civil work.
Cost	☺	☹	Spend to date is less than planned, but is expected to finish on budget.
Schedule	☹	☹	Behind schedule due to shortage of project personnel.
Risk	☹	☹	Risk of transportation problems for SAG Mill.
Requirements volatility	☹	☹	Demand growth indicates need to change the planned capacity to above the original specification
Operational support	☹	☹	Operational groups have not agreed to support the new equipment.
Training	☺	☺	Training program is ahead of schedule
Project resource issues	☹	☹	Shortage of project personnel is delaying tender evaluation for some items.
Suppliers	☺	☹	Suppliers currently engaged are meeting due dates and material needs.
Revenue	☹	☺	Revenue projections remain sound.

Fig. 7.6 Project progress scorecard for a plant upgrade

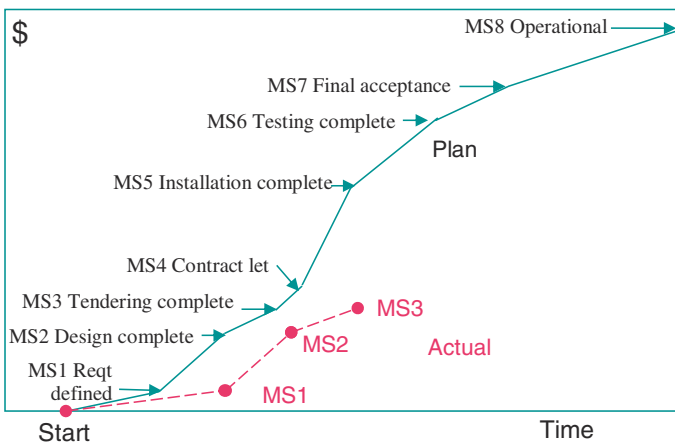

Fig. 7.7 Time and cost milestones (MS)—plant upgrade

A. Milestone	B. Cumul Planned Cost \$1000s	C. Cumul Planned Time months	D. Cumul Actual Cost	E. Cumul Actual Time	F. % over or under cost (B-D)/B	G. % over or under time (C-E)/C
1= reqt definition	10	2	12	2.5	-20%	-25%
2= design complete	45	3	40	3.5	11%	-17%
3= tendering complete	55	4	45	5	18%	-25%
END	250	6				

Fig. 7.8 Progress data—plant upgrade

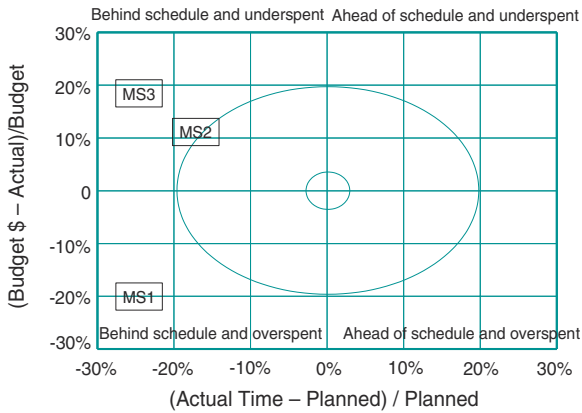

Fig. 7.9 Bulls-eye chart for project progress MS = Mile Stones

changes need to be taken into account. Portfolio managers must take action to prioritize and balance resources, including financial and staffing resources, and keep senior management and project managers well informed of developments and changes.

Figure 7.10 shows a summary report with one line per project in a portfolio. The status summary columns may be in the form of traffic lights with a red color indicating projects that are in trouble, green for satisfactory, and amber for in-between. For further detail, we would refer to reports relating to any particular project of interest.

7.14 Commissioning and Introduction into Service

Commissioning of new plant involves the builder or developer in starting up and operating the plant on a trial basis to check the functionality and satisfactory operation. A commissioning manager should be appointed, with technical

Row	Project	Team	Budget \$M	Prime Contractor	Budget Status	Schedule Status	Solution Status
1	Rail passing loop	Rail A	24.5	Railex	Fair	Good	Good
2	Wharf	Dock A	79.4	Asia Cons	Poor	Good	Good
3	Crane 150 tonne	Purch A	2.5	Crane All	Good	Fair	Good
4	Wagons	Rail B	10.0	Gowag	Poor	Fair	Fair
5	Control System	Info Tech	5.56	All Soft	Poor	Poor	Poor
6	Dragline Upgrade	Overhaul B	14.7	Huron	Poor	Fair	Fair
7	Road 124	Civil	22.6	Hollander	Good	Good	Good
8	Road 126	Civil	14.2	Hollander	Fair	Fair	Poor
9	Dam C	Civil	23.45	North Bund	Fair	Poor	Fair
10	Ship Loader	Overhaul C	78.63	Huron	Fair	Fair	Good

Fig. 7.10 Summary report for a project portfolio

support dependent on project size and complexity. The commissioning manager will develop a commissioning plan during the feasibility stage and will manage its implementation. The performance of the plant will be checked and any operating or functional issues will be addressed. This might include such factors as failure to meet performance ratings, leaks, equipment failures, or premature wear. Issues of safety in operation and of safe access for operators, maintainers, and materials must be addressed. Operations and maintenance should be represented as key stakeholders in the commissioning stage. It is important to have logistic support arrangements in place before introduction into service; otherwise, users gallop off with the equipment and there is no support when problems arise.

7.14.1 Operational Readiness

Operational readiness involves getting new or upgraded plant to the point where it can be handed over to operations. A site operations representative should be nominated, to represent the interests of operations in the installation, commissioning, and operational readiness processes. Defects identified during reliability testing

or during commissioning should be addressed before acceptance of the equipment, and safe operating procedures must be confirmed before handing over of the equipment to operations. It is common to find that there are some items that are less than perfect and lists are made of outstanding tasks. These lists are called *punch lists*. The punch list work is then completed, or some items may be agreed to be left until later.

Plans are to be developed for the transition from the commissioning project to operation at design capacity. The plans developed for all logistic support and information technology issues should come to fruition prior to the equipment entering service.

7.14.2 Training

Training is an important aspect of introduction into service. For both operators and maintainers, the following activities should be completed prior to introduction into service:

- Preparation of train-the-trainer material
- Preparation of training material
- Train-the-trainer training
- Training for operators and maintainers.

The operating and maintenance procedures must include the consideration and treatment of hazards, and contingency plans.

7.14.3 Introduction into Service

A key aspect of implementation is the introduction of assets into service. Prior to introduction the following steps are important:

- a. Logistic support developed and ready
- b. Training developed
- c. Training completed for relevant personnel
- d. Commissioning and run up completed
- e. Equipment pre-acceptance checks completed satisfactorily
- f. Operational readiness achieved
- g. Change management plan developed.

Once the above are satisfactorily completed, the asset is ready to be handed over to the user.

7.15 Change Management²

Change Management is a formal approach to managing workplace changes, intended to ensure that changes are assessed, managed, effectively controlled, communicated, and implemented successfully. Whenever changes are proposed, a change management process should be applied. The aim is to ensure maximum benefit is achieved from the proposed changes and that there are no adverse effects to health and safety, no damage to plant or equipment, that legislative requirements are upheld, and negative impacts on performance are avoided.

Managers should think through the impact of changes on all aspects of work activities during the planning process, although it must be accepted that not every potential impact of a change will be completely anticipated.

In any change, workers will want to protect their jobs and status and that of their immediate colleagues, and change is much simpler if these factors can be respected. Examine the implications of change from a worker/user point of view and consider the redeployment, training, or redundancy issues in advance of implementing change. Pilot studies, trial implementations of limited scope, and evolutionary changes may help. Ultimately, however, management must be prepared to take the responsibility for whatever hard decisions may be required.

Having decided on a change, conversion training from current processes and procedures must be provided. Involve the supervisor and other stakeholders, as local ownership of the solution is essential. Develop an implementation kit containing all the necessary equipment, documentation, and training procedures. Provide instructions, procedures, and check lists. Ensure sustainability of the solution through supporting facilities and materials as needed. If the new solution only works when senior management is enforcing it, then it is likely to fail. Ensure that necessary support is ongoing. If it really does not work, take a fall back position.

Danger points on implementation of a desirable change occur on the withdrawal of an implementation team and on a break in activity, such as a plant shut-down or a holiday period. Unless the change is well bedded down, operators may revert to the old way of doing things and the benefits are lost.

7.15.1 Change Analysis

Factors to be considered in change analysis include:

- Have a formal change proposal and evaluation procedure
- Details of the proposed change
- Reasons for change

² ISO 55001/2 Clause 8.2 Management of Change: “*Risks associated with any planned ... change shall be assessed... The organization shall ensure that such risks are managed...*”.

- Extent of change, e.g., retrofit or not
- Resources required for change
- Evaluate impact across all aspects of the capability
- Operational implications
- Logistic support implications
- Human resource implications
- Proposed timing
- Cost and benefit analysis.

7.15.2 Change Management Plan

A change management plan will involve such features as:

- Explanation of change and reasons for change
- Stakeholder involvement
- Operational plan, e.g., down time required
- Change/Modification details and procedure
- Areas impacted with details, e.g.,
 - Business
 - Mechanical
 - Electrical
 - Chemical
 - Process
 - Health and Safety
 - Environment
 - Regulations
 - Stores
 - Supply Chain
- Implementation plan, where, when
- Modification kits, tools, materials, and components
- Documentation changes
- Conversion training from current processes and procedures
- Disposal considerations
- Configuration update.

7.15.3 Approval of Changes

Changes will normally require the approval of an appropriate technical authority, typically the relevant engineering manager.

7.16 Exercises

7.16.1 *Self-Assessment Quiz 6.1*

1. Identify the project portfolios that are used in the capability development process.
2. Identify five general business considerations that should be taken into account in an asset development plan.
3. Who are the stakeholders in an asset development project and how should their views be considered?
4. What is meant by “level of service”?
5. Identify five points which should be considered in relation to the acquisition strategy for an asset.
6. How might you track the maturity status of projects in the Planning Portfolio?
7. What do the letters in the term RACI stand for?

7.16.2 *Pacific Earth Moving Part 3*

Pacific Earth Moving has obtained financial support and Board approval to purchase a range of additional earth moving equipment. The plan has been approved in principle, the main equipment to be acquired has been agreed, and an indicative budget has been approved.

The next step is to spell out more detail of the acquisition, including support facilities and services, and to create tender documents. The acquisition process will then proceed. The size and complexity of the acquisitions are greater than those previously undertaken by the company. Your group has been asked to advice on the following points:

- a. What organizational structure is needed to effect the acquisition process?
- b. What activities will the acquisition management group undertake?
- c. What types of management monitoring and reporting will be required?
- d. What types of risk may occur in such projects?

7.17 Exercise Solutions

7.17.1 *Self-Assessment Quiz 6.1*

1. *Identify the project portfolios that are used in the capability development process.*
 - a. Requirements Portfolio
 - b. Planning Portfolio
 - c. Implementation Portfolio

- d. In-Service Assets
 - e. Disposal Portfolio.
2. *Identify five general business considerations that should be taken into account in an asset development plan.*
Any five of the following:
- a. Meet the market need in terms of key outputs, characteristics, and features.
 - b. Profitable.
 - c. Affordable.
 - d. Technically feasible.
 - e. Timing feasible.
 - f. Risks identified and assessed.
 - g. No unsatisfactory risks.
 - h. Operationally and technically supportable.
 - i. Reliability, availability, maintainability satisfactory.
 - j. Meet design, environmental and safety standards.
 - k. Life adequate.
 - l. Retain some flexibility for revision as the acquisition develops.
3. *Who are the stakeholders in an asset development project and how should their views be considered?*
- a. Stakeholders are those people and functions that will be affected by the proposed plan. Survey their opinions and take them into account in developing, or even abandoning the plan. If necessary, form a stakeholder committee. For asset developments, the stakeholders normally include the relevant business, operations, and maintenance managers and staff. Where customers and suppliers are affected, they will potentially form part of the stakeholder group, subject to business confidentiality. The plan is more likely to succeed if the relevant groups have contributed to its development. At the same time, some stakeholders may resist the plan, particularly if they see it working against their interest, and it will be necessary to use management judgement and authority to present the rationalization for the plan from the overall business viewpoint. But suffer fools gladly—they may be right.
4. *What is meant by “level of service”?*
- a. Level of service relates to setting standards in such areas as performance, availability, timeliness of response to failures, and provision of information when problems arise. Level of service monitoring requires corresponding performance indicators. As an example, in a railway system, a performance indicator is the proportion of services that are not canceled, and a corresponding level of service is a specification that this should be, say, 97 % or more.
5. *Identify five points which should be considered in relation to the acquisition strategy for an asset.*

Any five of the following:

- a. What potential suppliers are available?
 - b. What major logistic issues are there?
 - c. How extensively should we canvas for potential suppliers?
 - d. Should we adopt a preferred supplier list?
 - e. Should we go to open tender?
 - f. Should we sole source?
 - g. Is development work required?
 - h. Should the acquisition/development be phased?
 - i. If phased, will changes to the equipment over the phases be a problem?
 - j. Should the acquisition be evolutionary, allowing for possible equipment improvement over the acquisition process?
6. *How might you track the maturity status of projects in the Planning Portfolio?*
- a. Figure 7.4 shows a scoring system which enables management to track the maturity status of these projects. As a project matures its total maturity score will progress towards 25 and we can monitor progress and manage priorities by reference to the maturity score at any point.
7. *What do the letters in the term RACI stand for?*
- a. Responsible, Accountable, Consulted, Informed.

7.18 Pacific Earth Moving Part 3 Solution

- a. Project Team Sect. 7.2.1
- b. Project Management Sect. 7.2.2, Activities Sect. 7.2.3
- c. Project Management Reports, Sects. 7.11–7.14
- d. Chapter 16, Sect. 16.6.

7.19 An Acquisition Decision

“We are going to have to get a new car,” said Sheila. “We need a four-seater at least, with somewhere to put a pram and a baby back-pack, besides shopping.”

Their present car was an MG two-seater sports model that dated back to Jock’s bachelor days. Jock said that he would look into the possibilities.

“The Cougar SS seems like a good option,” said Jock later that week. He was looking at a car magazine which gave the vehicle an enthusiastic write-up.

“It’s a sports sedan with a good sized boot and a terrific performance,” he said.

“Let me see,” said Sheila. She turned over a few pages.

“This looks more realistic,” she said, and handed the magazine back to Jock, open at a page which showed a picture of a medium sized Toyota hatchback.

Jock groaned inwardly.

“I need to be able to put things in the back, without having to lift them over a sill,” said Sheila. “And anyway, we don’t need fancy performance for doddling around suburbia.”

“We need to get on with buying it,” Sheila went on. “We can trade in the MG at the Toyota dealer on Burwood Highway.”

“Okay,” he said.

Jock’s domestic scene was looking good, but there was trouble with the project that he was managing. A few days later at work he headed for the water cooler only to find his boss, Sam, already there.

“Project 413 is behind schedule,” said Sam, who was not strong on small talk.

“I’m pressuring Dead Sea Systems but these software integration projects are pretty difficult to push along,” said Jock. “We’ve tried some strong arm stuff already. I’ll have another go at getting to the bottom of the problem with the project people there.”

“Okay, but don’t let them pass the blame back to us,” said Sam as he left.

Veronica, Jock’s favorite work buddy arrived as Sam departed.

“Trouble in’t mill?” she said.

“I just can’t get any sense out of Dead Sea on this 413 project,” said Jock.

“My nephew works for them,” said Veronica as Jock was about to start on a tirade of criticism of Dead Sea.

“Hmm,” said Jock, “Maybe you could get some inside info?”

.....

“Anything new from Dead Sea,” asked Jock when he met Veronica at the water cooler a week later. Veronica didn’t answer directly.

“Software projects are difficult to manage, and it’s not always the project people’s fault,” she said.

“Tell me something!” said Jock. “I remember a project that I was on for St Helens Glass. They asked our team leader how long it would take and he said, ‘6 months’.

“It was January at the time, and the St Helens guy said, “So you can finish it by July!”

“Yes,” said our guy, “If we get the go-ahead today.”

“Then nothing happened until another meeting in May, when the St Helens guy asked if the software would be ready by July ‘as promised’.

“Does that mean that you are approving the project?” our manager said.

“And they did. It still took 6 months, but somehow the delay had become our fault.”

“There are a lot of witty sayings about software projects and they are all true,” said Jock. “Like—projects quickly become 90 % complete and then remain that way indefinitely.”

“And, you can browbeat a programmer into committing to a deadline, but you can’t make him meet it,” added Veronica.

“So what is happening at Dead Sea,” said Jock trying to get to the point.

“Well everything on Project 413 was given top priority after they got a rocket from us earlier, but some of the work is sub-contracted to Uluru Developments and they haven’t delivered.”

“Well, sub-contractors are the prime contractors responsibility,” said Jock, feeling stern and worried at the same time. “You don’t happen to know anyone at Uluru do you?”

“No,” said Veronica.

Jock wasn’t supposed to deal directly with sub-contractors but after a while he couldn’t resist. He rang Uluru and asked if anyone knew about Project 413. He got through to Charlie McSporran.

“Your not related to the McSporrans of Dunbar Street are you?” said Jock.

“Aye,” said Charlie, “I went to Dunbar Street Primary right enough.”

It took them half an hour to get on to Project 413.

“What’s the hold up?” asked Jock.

“It’s you blokes,” said Charlie. “We can’t get on with our part until your development boys release the operating specs for the radiation sensors.”

Jock nearly choked.

“Who are you in contact with at our end?” he said.

“Stonewall Jackson,” said Charlie.

Later Jock wondered if there was any solution to stuff ups like Project 413. The best he could come up with was the two phrases “Date of Decision” and “In Service Date”. If every manager had to specify those in every meeting and every report, maybe some sort of awareness would creep in, he thought.

Chapter 8

Life Cycle Costing

Abstract The aim of this chapter is to describe the technique of life cycle costing and to illustrate it with an example. We also develop a life cycle asset management plan for an item. *Outcomes* After reading this chapter you will understand the reason for life cycle costing and have seen a check list of factors that go into a life cycle costing analysis. You will have seen an example of a life cycle cost analysis. You will understand the concept of a life cycle asset management plan.

8.1 Life Cycle Costing

Life Cycle Costing (LCC)^{1,2,3,4} is the estimation of the cost of acquiring, commissioning, operating, maintaining, and disposing of equipment. It is a “cradle to grave” cost analysis. The aim of life cycle costing is to ensure that all relevant costs are identified, and that through life costs are considered at the planning, acquisition, and budgeting stages.

8.1.1 Why Do We Need Life Cycle Costing?

We need life cycle costing to assist us with the following types of asset management decisions:

- Acquisition decisions, with consideration of the life cycle costs of different acquisition options
- Life cycle asset management planning as an input into determining the operating and maintenance resources and budget for in-service assets
- Replacement decisions.

¹ Australian Standard AS 4536 Life Cycle Costing.

² AS/NZS 15288 Systems Engineering—System life cycle processes.

³ IEC 60300-3-3 Life Cycle Costing.

⁴ ISO 55002 Clause 6.2.1.3 d.

8.2 Acquisition Decisions

The first reason for carrying out life cycle costing arises in the preacquisition stage of an asset, where we need to determine life cycle costs, initially at a broad brush level, to assist with acquisition analysis and decision making among possible options. The key point is to avoid doing something stupid, such as neglecting or badly under or over estimating a major cost area.

The aim of life cycle costing at the acquisition stage is to ensure that all relevant costs are identified, and that through life costs are adequately considered. Life cycle costing is applied initially at a broad brush level. Costs will later be refined in the course of making a firm acquisition decision.

Life cycle costing considers acquisition cost but also gives attention to operating costs, consumables, life of the item, spares costs, life of key components, diversity of spares and tools, and issues related to training.

Figure 8.1 illustrates the stages in the life cycle of an equipment, showing schematically the cumulative cost and the opportunity to influence costs. The opportunity to influence costs is concentrated at the planning and acquisition stages. It is important in selecting equipment that we take due account of logistic support considerations, otherwise equipment support costs, performance and availability may produce poor results that negate perceived advantages in initial cost. In Fig. 8.1 the acquisition costs are dominant, and this is often the case for passive items. However, for items such as vehicles or plant, or anything that consumes fuel, the operating costs may be the most significant cost area. In this case operating costs should be an important consideration in equipment decisions.

An illustration of the application of life cycle costing relates to a company which builds prisons. In some cases it will be competing for a contract to design and build a prison and then hand it over to another organization to run it. In other cases the contract will be to design, build, and operate the prison. In the first case, the company will create a design which is inexpensive to build, but gives little attention to the operational aspect. If it did otherwise it would almost certainly not

Fig. 8.1 Life cycle stages

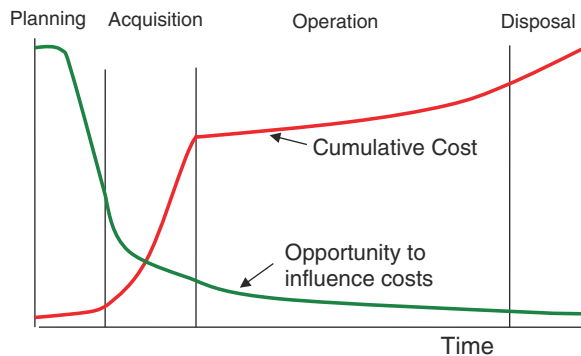

win the contract because its tender price would be too high. In the second case, the design would take account of the fact that the company would itself be operating the prison, and they would therefore aim to minimize costs over the whole life cycle of the contract.

8.3 Life Cycle Asset Management Plan

A life cycle asset management plan is a plan formed by identifying the operating regime of the asset, the associated maintenance, repair and overhaul activities, the planned life, and the disposal plan of the item. Life cycle costing involves creating a life cycle asset management plan. In fact the plan and the costing occur together, and the need for the plan is the second reason for carrying out life cycle costing.

8.3.1 Why Do We Need a Life Cycle Asset Management Plan?

We need a life cycle asset management plan as a basis for planning resources and budgets for support of the asset.

The life cycle asset management plan can be broad brush at the preacquisition stage but will then be refined at the feasibility analysis stage and again when the asset is in service.

8.3.2 Sources of Information

Maintenance requirements will include routine maintenance and an estimate of nonroutine maintenance requirements. Logistic support analysis, carried out as part of the feasibility phases of the development will provide an input into the Life Cycle Asset Management Plan.

Basic information relating to the maintenance regime will normally be supplied by the equipment manufacturer. However, this may need adjustment depending on the planned level of activity and the operating environment. If operating rates, for example, are significantly higher than normal or environmental condition significantly more severe, then the life cycle asset management plan and costs must take this into account. The plan must also take account of the relevant regulatory regimes. If the equipment or the application is nonstandard then an analysis technique such as Reliability Centered Maintenance can be used to determine an appropriate maintenance policy.

8.4 Replacement Decisions

The third reason for life cycle costing relates to replacement decisions. As assets age, we need to consider replacing them. The replacement decision is based on comparing the annual cost of maintaining the existing asset with the equivalent annual cost of the new asset. Replacement should occur once the annual maintenance cost of the old item exceeds the equivalent annual cost of the new item, calculated over its life cycle. Thus the life cycle cost of the new item is a significant consideration in the replacement decision. In a later chapter, we shall consider replacement decision analysis in more detail and bring a range of factors into the discussion.

8.5 Life Cycle Planning and Costing Elements

The topics listed in this section form a check list of items to be considered in the Life Cycle Planning and Costing process. The main areas considered are:

- Acquisition
- Installation
- Transportation
- Operations
- Computer systems
- Engineering
- Maintenance
- Support services
- Supply
- Spares/Cataloging
- Training
- Disposal.

8.5.1 Acquisition

- Preacquisition and acquisition project costs
- Prime equipment cost
- Support equipment cost
- Supporting utilities
- Test and evaluation
- Operational facilities
- Supporting computer and information systems
- Technical data and related systems
- Storage, handling, and transportation
- Initial training development
- Initial training
- Commissioning/introduction into service.

8.5.2 Operations

- Net personnel requirements for operations
- Materials and consumables
- Energy (e.g., power, fuel)
- Personnel recruitment
- Personnel training
- Personnel transport and accommodation if required
- Operational documentation
- Information technology systems and training
- Equipment and facilities
- Net personnel cost
- Net operating cost.

8.5.3 Maintenance

- Routine maintenance including lubricants and consumables
- Breakdown maintenance and planned availability
- Planned upgrades
- Major overhauls
- Maintenance labor
- Maintenance training
- Maintenance facilities
- Maintenance documentation
- Contractor services, selection, and management
- Maintenance IT support
- Engineering support
- Engineering modifications
- Configuration management
- Repair parts (rotables)
- Spare parts
- Life of major assemblies were different from the complete equipment.

8.5.4 Support Services

- Office facilities
- Corporate management
- Administrative overheads
- Information technology
- Insurance
- Human resource management

- Consumables, spare parts, and materials in support areas
- Warehousing facilities
- Packaging, shipping, and transportation.

8.5.5 Disposal

- System shutdown
- Disassembly and removal
- Recycling or safe disposal
- Product residual value.

In the case of buildings, the industry is well served by architects and quantity surveyors. We briefly summarize some main headings:

8.5.6 Buildings—Design and Construction

- Market research
- Development of concept and detailing of needs
- Preparation of requirement specification of the building
- Site acquisition
- Design and design documentation
- Construction tendering and selection
- Construction planning
- Construction management
- Construction
- Midlife refurbishment, décor, lifts, escalators, and gates.

8.5.7 Buildings—Operation, Maintenance, and Disposal

- Owners' operational outgoings, e.g., cleaning, power, and gardening
- Owners' maintenance outgoings, e.g., maintenance of heating, ventilating and air conditioning, lifts, escalators, painting, water, and drains
- Supplies
- Support services
- Disposal value.

8.6 Life Cycle Costing Example

In Life Cycle Costing the costs associated with acquisition, operation, and through life support are brought together in a spreadsheet or in a similar purpose built system, and the total costs across the life cycle are calculated. To build the spreadsheet we need to establish the life cycle asset management plan, which involves determining the operation, maintenance, repair, and overhaul activities which will be required over the life cycle. Thus, although the emphasis in the techniques is on “costing,” we see that the life cycle asset management plan must be created before the costs can be estimated.

As the life cycle extends over a period of years, discounted cash flow techniques are used to calculate Net Present Value and the Equivalent Annual Cost. Figure 8.2 shows an example of the life cost analysis for a Circuit Breaker Bay in an electricity transmission system. The details are simplified to show the principles involved, and no operating costs are shown as they are not a significant issue in this case. The Bay has a 30-year life, with the first 16 years being shown in Fig. 8.2.

The year labeled –1 is the year prior to acquisition, when initial engineering analysis, acquisition project work, and vendor selection are carried out. Year zero is the year of acquisition. Life cycle cost elements include the planning and management of the installation; the building of roads, paths, and ducts; the acquisition of the main switchgear and of the other items shown under the “year zero” heading in column A.

The life cycle asset management plan is formed by deciding—on an initial planning basis—the operating life, maintenance, overhaul, and disposal plans. These are then costed and linked to the life cycle time frame.

In the example the life cycle asset management plan involves:

- A planned life of 30 years
- Annual maintenance at a cost of \$3,000 per year
- 3 year cyclic maintenance at a cost of \$6,000 per event
- Midlife upgrade at a cost of \$250,000
- Disposal after 30 years at a cost of \$48,000

In Fig. 8.2, the annual maintenance costs are shown in row 15, the 3-year cyclic costs are in row 16, and the midlife upgrade is in row 17, specifically at cell R17. The disposal cost of \$48,000 is incurred in year 30, which is not shown in the figure, as this only shows years up to 16.

Life cycle costs are then calculated, specifically the net present value and the equivalent annual cost. Inflation is allowed for by expressing costs in year zero values and using the real rate of interest, which is estimated at 4 % and shown at cell C2. The Net Present Value of costs is \$1,619,000, shown at cell C20 and the Equivalent Annual Cost is \$94,000 shown at cell C21.

The costs then form the basis for budgeting for acquisition and sustainment and the life cycle asset management plan forms a basis for maintenance and logistic resource provisioning.

The screenshot shows an Excel spreadsheet titled "Microsoft Excel - LCC Bay". The formula bar displays the NPV calculation: $=B19*(1+\$C\$2)+C19+NPV(C2,D19:AG19)$. The spreadsheet data is as follows:

	A	B	C	D	E	F	G	H	I	J	K	L	M	N	O	P	Q	R	S
1	Year	1	2	3	4	5	6	7	8	9	10	11	12	13	14	15	16		
2	Real rate of interest		4.00%																
3	Prior year																		
4	Initial engg analysis & planning	30																	
5	Acquisition project + vendor selection	35																	
6	Acquisition Year																		
7	Installation plan & mgmt		45																
8	Roads, paths, ducts, ...		75																
9	Main switchgear		950																
10	Secondary wiring & controls		125																
11	Installation and commissioning		65																
12	Documentation		10																
13	Initial spares & consumables		45																
14	Maintenance																		
15	Annual maint			3	3	3	3	3	3	3	3	3	3	3	3	3	3	3	3
16	3 year cyclic maint				6														
17	Upgrade																		250
18	Disposal																		
19	Totals		65	1315	3	3	3	3	3	3	3	3	3	3	3	3	3	3	259
20	NPV																		1619
21	EAC																		94

Fig. 8.2 Life cycle costs for a circuit breaker bay

8.7 Input to Plans and Budgets

The life cycle plan and costs have several uses as follows:

8.7.1 Acquisition

In developing a business case for an acquisition project the results of Life Cycle Planning and Costing feed into the project proposal.

8.7.2 Support Facilities and Logistics Planning

Life Cycle Asset Management Plans form building blocks for identifying the requirements for support facilities and logistics. This leads to decisions regarding level of repair and outsourcing. These features are illustrated in Fig. 8.3.

8.7.3 In-Service Asset Management Planning and Budgeting

Life cycle asset management plans for individual assets or groups of similar assets form building blocks from which plans and budgets are generated for in-service assets. Time-based plans (e.g., a one year or 5-year asset management plans and budgets) are formed by consolidating the asset and support facility requirements across the whole asset portfolio.

To do this we need to know the repair, maintenance, overhaul, and replacement plan for the individual assets or groups of similar assets so that we can develop an aggregated plan for the asset portfolio as a whole. The planning will take account of the current age and condition of the assets, using the original life cycle plan and costings as a starting point.

Costings for individual assets feed into the organization’s budget for the following year and for longer planning periods such as a 5-year asset management plan. The process is illustrated in Fig. 11.4.

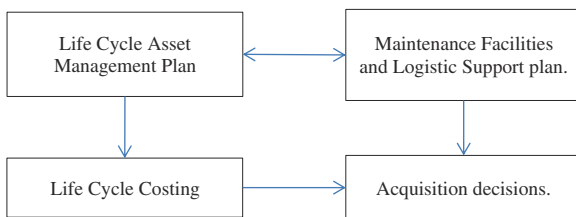

Fig. 8.3 Asset management plan and costing at the acquisition stage

8.8 Exercises

8.8.1 Self Assessment Quiz

1. What is the aim of life cycle costing?
2. What is a Life Cycle Asset Management Plan?
3. Identify 5 cost elements in life cycle costing related to asset acquisition.
4. Identify 5 cost elements in life cycle costing related to the asset operations.
5. Identify 5 cost elements in life cycle costing related to asset sustainment.
6. Identify three different types of use of a life cycle planning and costing.

8.8.2 Solution to Self Assessment Quiz

1. *What is the aim of life cycle costing?*
 - a. The aim of life cycle costing is to ensure that all relevant costs are identified, and that through life costs are considered at the planning, acquisition, and budgeting stages.
2. *What is a Life Cycle Asset Management Plan?*
 - a. A Life Cycle Asset Management Plan is a plan formed by identifying the operating regime of the asset and the associated maintenance, repair, and overhaul activities, the planned life and disposal plan of the item.
3. *Identify 5 cost elements in life cycle costing related to asset acquisition.*
 - a. Any 5 items listed in Sect. 7.3.1.
4. *Identify 5 cost elements in life cycle costing related to the asset operations.*
 - a. Any 5 items listed in Sect. 7.3.2.
5. *Identify 5 cost elements in life cycle costing related to asset sustainment.*
 - a. Any 5 items listed in Sects. 7.3.3 or 7.3.4.
6. *Identify three different types of use of life cycle planning and costing.*
 - a. Acquisition decisions, with consideration of the life cycle costs of different acquisition options.
 - b. Life cycle asset management planning as an input into determining the operating and maintenance resources and budget for in-service assets.
 - c. As an input into replacement decisions where the annual cost of an old item is compared with the equivalent annual cost of the new.

Part III
Managing In-service Assets

Chapter 9

Know Your Assets

Familiarity breeds

Abstract The aim of this chapter is to draw attention to the need for asset managers to be familiar with their assets in a technical, business, and operational context. The role of the asset manager involves being well informed across the application of the assets, although this does not mean that the asset manager will be the ultimate expert on any one functional aspect. The asset manager will have an integrated view of the assets as a whole and will understand the relationships, interdependence, and degree of criticality among the deployed assets and be aware of asset condition. *Outcomes* After reading this chapter you will be aware of the importance of understanding the range of assets which are used in the business, their roles, the technologies involved, and the relative criticality of particular assets. You will be aware of the value of expert teams which have in-depth asset knowledge of particular asset types. You will be aware of the significance of bottlenecks that can occur particularly in flow process businesses and of possible backlogs of work and of asset condition. These are factors which may require an adjustment of resources.

9.1 Awareness of Key Assets¹

Successful asset management is dependent on managers having a clear understanding of the assets that are required to physically sustain the business and to keep it profitable. There is value in having a *register of key assets* of the organization which includes information on their leading specifications and age. Having a high standard of awareness of the key assets promotes good asset management. In particular, it focuses the attention of employees at all levels on the role and significance of the assets on which the organization depends. It is also valuable to

¹ ISO 55001 Clause 4.3: “The organization shall determine the boundaries of the asset management system...”.

promote an awareness of the range of assets and their interrelationship in providing essential capabilities.

Key aspects of asset knowledge can be summarized as:

- Awareness of key assets
- Block diagrams of major product flows, systems, etc.
- Criticality of assets from technical and business viewpoints
- Awareness of expert individuals or teams who have fully detailed knowledge of particular asset types
- Asset utilization
- Bottlenecks
- Backlogs
- Asset condition

Asset management information systems contain a vast amount of detailed information. In order to see the wood for the trees, the register of key assets, which is essentially a report generated from the full asset register, lists the main items at a senior management decision level. The register of key assets is a useful document in capability development planning and capital budgeting. This document will incorporate information such as:

- Asset/capability title
- Brief configuration detail
- Location
- Age
- Asset condition
- Estimated remaining life
- Book value
- Replacement cost
- Recent history, e.g., last overhaul or upgrade date
- Known issues
- Known plans

There is also value in having maps, plans, satellite images, photographs, and surveillance images at various levels of detail, making it as simple as possible to understand the location and nature of assets and their current condition.

9.1.1 Examples

An indication of the range and complexity of industrial assets is given by Fig. 9.1, which shows the assets at a mine site. The actual mining operation is not in the picture, and requires a further range of assets in the form of mining machinery and supporting services. Most industrial complexes involve a wide range of types of assets.

A statement of the quantity of assets under management, of the budget involved and of the work carried out annually is valuable as an indicator to staff, to

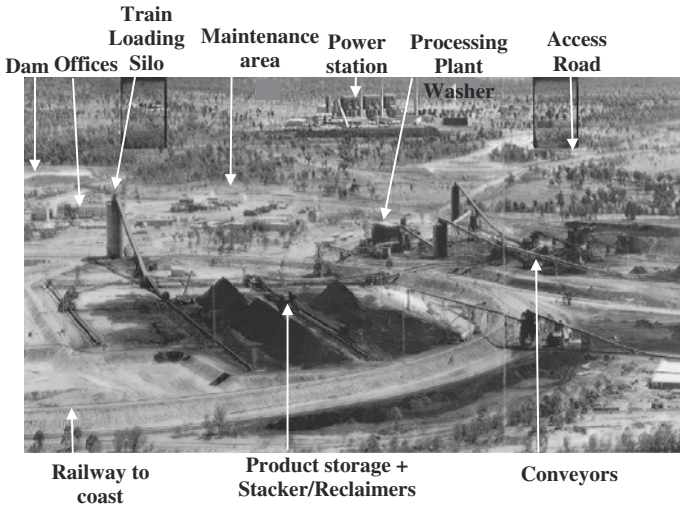

Fig. 9.1 Mine site assets

Asset	Quantity
Track	1800 kilometers
Electrification system	1600 kilometers
Turnouts	4715
Signals	3683
Train services per day	2500
Customer journeys per day	2.7 million
Annual capital budget	\$1billion
Annual maintenance budget	\$1 billion
Annual track reconstruction	42 kilometers
Annual rerailing	74 kilometers
Annual overhead wiring rebuild	16 kilometers
Turnout renewals	60
Track circuit renewals	155
Source: RailCorp New South Wales Asset Management Group	

Fig. 9.2 A railway asset summary

senior management, and to the public of the scale of the asset management task. Figure 9.2 gives an example.

At an electricity transmission company the CEO arranged for video screens in the head office to display, on a real-time basis, the electricity throughput of each of the company’s major transmission lines. This drew the attention to the fact that the important action was happening out there in the field, and that the activities of the office staff were essentially in support of the physical transmission process.

9.2 Acquisition of Asset Knowledge

The acquisition of asset knowledge requires a formal effort. Asset managers should always take the trouble to learn about the assets under their jurisdiction. A good approach to this is to assign young engineers the task of documenting areas of plant and explaining their workings in a descriptive document. Staff generally can then be made aware of the contents of the descriptive documents and they can be used in induction and training programs.

9.3 Block Diagrams

System block diagrams help in understanding the role and criticality of assets. A very simplified block diagram based on a power station is shown in Fig. 9.3.

The following are some rules for creating block diagrams:

1. The *function* of each component or block should be identified.
2. Each block should be *physically* identifiable.
3. The blocks should be mutually independent (as far as reasonably possible).
4. Links, e.g., pipes, wiring, couplings should be assigned to specific blocks, or form their own block where justified.
5. Each block should preferably focus on one main technology, e.g., mechanical, electrical, hydraulic, PLC.

9.3.1 Information Required Per Block

The following points give an indication of the type of information required in relation to each block:

- Function of block and basic operating principles
- Inputs
- Outputs

Fig. 9.3 Power station block diagram

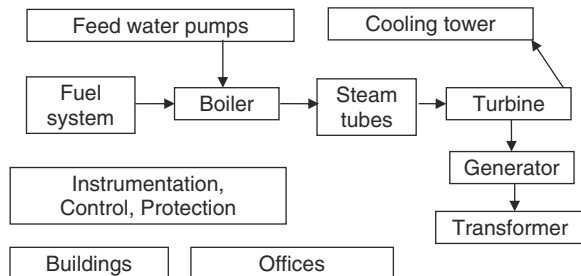

- Structure, e.g., assemblies, components, and functions and operation of these
- Operating norms, e.g.,
 - Production or flow rate
 - Yield
 - Pressure
 - Temperature
 - Other gauge settings.

9.3.2 Drawings

To fully understand the detail of a system it may be necessary to study the engineering drawings or piping and instrumentation diagram. This can be a worthwhile exercise. As my father used to say (probably quoting the Duke of Wellington), “time spent in reconnaissance is seldom wasted.”

9.4 Criticality

For asset planning we need to understand the *criticality* of the various items. This will be in terms of potential production losses if they fail, and also reflect safety and environmental issues. Criticality analysis helps us to prioritize maintenance work and also provides a basis for designing-in redundancy and making contingency plans. There are many examples where the loss of a production unit has caused major disruption on a statewide basis, such as the Varanus Island gas terminal in Western Australia, where a failure cut off one-third of the state’s gas supply. A similar example is the Longford gas plant in Victoria where a failure cut off the gas supply to Melbourne for several weeks. In the aftermath to this latter event, other sources of gas supply were expanded so that risk was reduced.

9.4.1 Example—Chemical Plant

In the example in Fig. 9.4 which is from a chemical plant, the heat exchangers were identified as the most critical assets as they are not duplicated and can only be repaired off-line, a time-consuming process involving extensive delays for cooling and start-up. To offset the criticality we need to prioritize these items and ensure that they meet fitness-for-service criteria at a standard sufficient to sustain them over a defined planning and inter-inspection period.

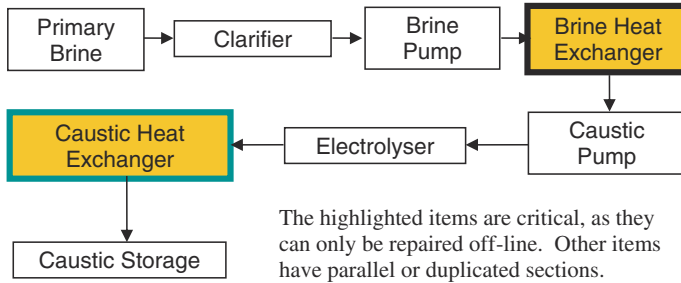

Fig. 9.4 Block diagram and criticality—chemical plant

9.4.2 Example—Mining Site

In the example shown in Fig. 9.5 from a mining site, criticality is based qualitatively on the following factors:

- Failure Category (Unlikely, Adequate warning, Sudden)
- Failure Impact (Low, Medium, High)
- Ease of Repair (No shutdown, Shutdown area, Shutdown plant)
- Mean downtime (Low, Medium, High)
- Cost of Breakdown (Repair cost only, Minor production loss, Major production loss)

	A	B	C	D	E	F	G	H	I
	Equipment Name	Number off	Failure rate off 1=Low 2=Medium 3=High	Safety-Enviro impact. 1=Low. 2=Medium. 3=High.	Ease of repair. 1=No shutdown reqd. 2=Shutdown of area. 3=Shutdown of plant	Mean Down Time 1=Low. 2=Medium. 3=High	Cost of Breakdown. 1=Repair cost only. 2=Minor production loss. 3=Major production loss	Criticality = 3* C*(D+E+F +G)	Comment
1	Drilling rigs	2	3	2	1	2	1	54	Can lease if critical
2									
3	Dragline	1	2	1	2	2	1	36	
4	Coal loaders	8	2	1	1	2	2	36	6 out of 8 reqd.
5	Dump trucks	14	2	1	1	1	1	24	10 out of 14 reqd
6	Transport	12	1	1	1	1	1	12	
7	Main conveyors	2	2	3	3	3	3	72	
8	Subsidiary conveyors	12	2	2	2	2	2	48	
9	Stacker-reclaimer	1	2	1	2	2	2	42	
10	Blender	1	2	1	2	2	2	42	
11	Coal washer	1	1	3	2	2	2	27	
12	Loading silo	2	1	1	2	2	2	21	Old silo retained as standby
13	Rail track	1	1	3	2	2	3	30	Contractor
14	Rail system	1	1	3	2	1	2	24	
15	Rail locos	6	1	1	2	2	2	21	Contractor
16	Rail wagons	248	2	2	2	2	2	48	More redundancy reqd
17	Unloading bay	1	1	1	2	2	3	24	
18	Port stacker-reclaimer	1	1	3	2	3	3	33	
19	Dozers	1	1	3	2	3	3	33	
20	Port conveyer	1	2	1	2	2	3	48	
21	Ship loader	1	2	1	2	2	3	48	

Fig. 9.5 Criticality analysis of mining assets

9.5 Expert Teams

An expert team is a group of people with specialized knowledge of the working of a particular functional area or of a particular type of plant. Figure 9.6 shows an example of the type of membership of a team. The technical nature of the equipment and the processes makes it essential to have people who understand the plant in order to make sound decisions. Forming expert teams give plant personnel status and motivation. They take their expertise seriously and it is taken seriously by management.

In some cases the expert team may be formed by linking experts across sites. For example, a mining company may have an expert team with knowledge of a particular type of process or machine, such as draglines. Technical problems relating to draglines, such as root cause analysis of failures, would draw on the knowledge of this group.

However, it is important to keep focussed on the objectives of the organization and not get side tracked into displacement activities.

9.6 Bottlenecks

A bottleneck is a part of a process which has limited capacity, and therefore constrains the throughput of the system as a whole. In systems involving simple flow processes, effective improvements can only occur at bottlenecks. However, bottlenecks are not always constant, but may depend on the production or product mix. For example, in a production facility, we received a large order for product requiring heat treatment. This made our heat treatment plant into a bottleneck at that time, whereas with a normal mix of orders, we had plenty of heat treatment capacity. We should therefore consider how demand on machines varies with the product mix before focusing on a current bottleneck. Also, if we act to remove

Fig. 9.6 Expert team

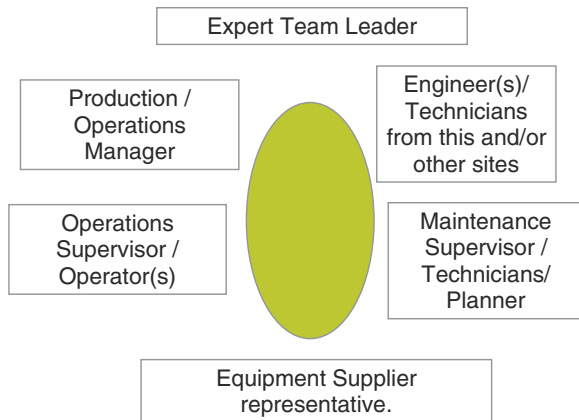

an existing bottleneck, the effect may be limited by causing a new bottleneck to appear in a different part of the process.

De-bottlenecking involves making investments that are cost-effective in increasing product flow or reducing costs by relieving bottlenecks. As part of our asset knowledge we should be aware of existing and potential bottlenecks, if any, and seek to relieve bottlenecks where this can provide the most cost-effective improvements. The following steps are recommended for this purpose:

1. Flowchart the process, identifying operations, queues, storages.
2. Identify demand drivers (e.g., customer pull), demand rates, and translate into average required throughput rates for each part of the process. Take account of average and peak loads.
3. Identify capacity constraint areas—potential bottlenecks.
4. Calculate maximum throughput rate of areas, using averages, then allow 25 % extra for queueing effects. Take maintenance into account.
5. Recognize areas as (a) complete bottlenecks, (b) occasional bottlenecks, (c) excess capacity.
6. Consider variability in service times. A high degree of variability (as opposed to consistent, even performance) leads to longer queues and/or larger stockpiles.
7. Treat bottlenecks by adjusting capacity, reducing variability, or prioritizing flows.

9.7 Backlogs

The buildup of backlogs of work in particular areas is relatively easy to identify, but is often ignored by management. Backlogs are an indicator of lack of resources in particular areas, whereas lack of a backlog indicates adequate resources. Watch out in case there is some deliberate attempt to distort the picture. Management should respond to the buildup of backlogs by checking the reason and taking steps to reduce the backlog, or to contain it to reasonable levels.

9.8 Asset Condition²

Asset condition will usually deteriorate over useful life. Normal depreciation reflects this loss of condition in a general sense. If the condition of an asset is such that it can no longer serve its functional purpose, then corrective action should be taken to restore the functionality. Considerations are:

- Asset condition in regard to primary functionality and safety.

² International Infrastructure Management Manual. Association of Local Government Engineering NZ Inc. P.O. Box 118, Thames, New Zealand. www.ingenium.org.nz. Section 2.5.

- Asset condition in regard to expected level of service, particularly for those which deteriorate gradually and where the condition can then be restored, such as roads and buildings.

An approach is to assess condition on a specified scale. This may be a 1–5 scale such as:

- 1 = very good
- 2 = good
- 3 = moderate
- 4 = poor
- 5 = very poor.

For comparison purposes it is important to have agreed systems for assessing asset condition.

The response to deteriorating asset condition can involve a timescale over which corrective action needs to be taken, such as:

- Immediate,
- Within 1 month,
- Within 3 months,
- Within 1 year,
- Monitor at next inspection.

For any given equipment type, the details can be spelled out in an inspection or condition monitoring procedure. The key point is to be aware of asset condition and to respond in time to sustain the functionality and safety.

9.9 Plant Criticality Exercise

The senior management of a process plant wants to increase production. They are considering adding another product line and have a cost estimate of \$750,000. You are a plant engineer and are asked to comment on the proposal. You know that the standard of reliability of the equipment is not high and that down time is significant, particularly for the furnace and blower.

The plant produces intermediate plastic products. Raw material is fed from any of three hoppers into either of two feeder lines. The feeder lines pump material via a flow controller, through a furnace, and then into a blower where it is formed into continuous sheet. There is a pump for each feeder line. From the blower, the material can be fed to any of five existing product lines. Give answers in dot point form to the following questions.

- Draw a block diagram of the process.
- Which stages of the process are critical from an operational point of view?
- What do you suggest to management?
- How would you back up your recommendations?

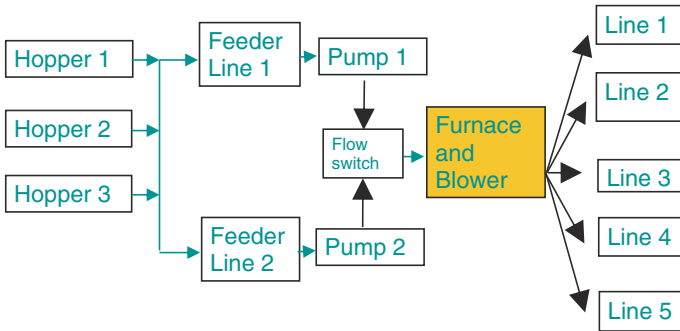

Fig. 9.7 Plant criticality block diagram

9.10 Plant Criticality Exercise Solution

The furnace and blower are critical. Increasing their availability through better maintenance planning, maintenance resource provision, and maintenance execution are recommended. In practice, this solution enabled increased production targets to be met without installing a new product line (Fig. 9.7).

Figure 9.8 illustrates the relative cost-effectiveness of the solution options.

9.11 Look Back in Embarrassment

“You’re such a wiz at asset management—I wonder if you ever did anything wrong?” said Veronica as she met Jock at the water cooler.

“There was one thing,” said Jock.

“Only one?”

“Only one I remember.”

“Tell me.”

Fig. 9.8 Cost-effectiveness of de-bottlenecking—example

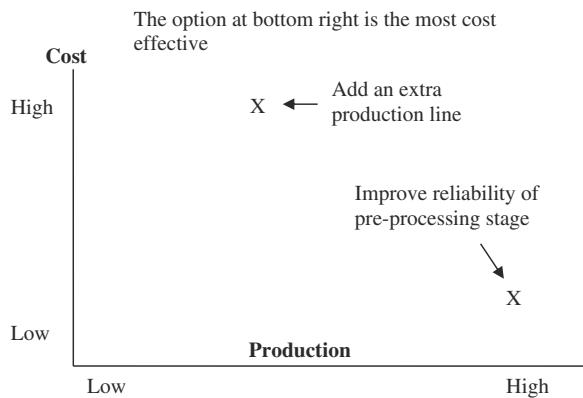

Okay, “said Jock,” I’ll own up to it. It was in my early days out of college. I was in charge of a repair workshop, way up-country. Most of the focus of my life at the time was on sport and running a dance band and all I really took note of in the workshop was keeping up the stocks for the vending machines. There was a heap of complaints if they ran out of anything.

It was a couple of years later, after I had moved on, that I realized some of the things that I should have been doing and looked back in embarrassment.

There was a bottleneck in our production—I’m sure now that people were trying to tell me about it at the time. It was in textile work—not a big technical focus but there was a lot of it. We only had one textile worker and she was always flat out and holding things up. I could have easily recruited another textile worker when one of the staff from another area left, but my mind just wasn’t into gear on that sort of thing. It’s definitely not covered in an engineering degree.”

“It doesn’t seem such a big deal,” said Veronica.

“Maybe not, but I still feel stupid about it,” said Jock.

“I’ve been thinking about ways of getting it wrong,” said Veronica sometime later.

“Yeah?” said Jock, “like what?”

“Well, first you can have a senior management that is completely out of touch.”

“That’s quite common,” said Jock.

“I was reading about the high priests of the Incas sacrificing virgins to stop the advance of the Spanish conquistadores,” said Veronica.

“That’s a good example, but be careful, the Incas might sue you for defamation,” said Jock.

“Then there is not reacting to known issues, like ignoring obvious worn out stuff. And then just not being aware if issues that you—or someone—should be aware of, such fatigue failure or insulation degradation,” said Veronica.

“And then there’s just bad luck,” said Jock.

“Yeah,” said Veronica. “I think I’ll buy a Lotto ticket.”

Chapter 10

Asset Continuity Planning

Abstract The aim of this chapter is to describe how to plan for the provision of assets which are required to meet an ongoing need. This is a very common situation, in which demand for a type of asset continues into the future, but older items require replacement and variations occur, due to the changes in demand levels and to market and technical developments. *Outcomes* After reading this chapter you will have learnt how to plan the purchase of items to sustain an ongoing capability requirement, by calculating the preplan capability gap and then working toward the planning horizon calculating the purchase needs year by year and making suitable purchase decisions. You will become familiar with a spreadsheet-based method for carrying out the necessary calculations and for graphically illustrating the gap analysis and the acquisition costs.

10.1 Asset Continuity

Asset continuity refers to the common situation where the requirement for the services delivered by a given type of asset is ongoing. Most asset management situations involve planning for the continuity of an existing system of assets, the role of which will continue on into the future. Each asset will have its own life cycle, but the overall situation is more complex than might be suggested by a focus on the life cycles of individual assets or of particular asset types alone. The “inputs to capability” of ranges of major asset types frequently overlap, as do the requirements for supporting asset systems and facilities.

An example is a trucking business, where continuity is required in meeting the demands of the business, so that disposal of old trucks at the end of their useful life is matched by acquisition of new trucks, with variations as necessary to reflect business and technical developments. At the same time, the support facilities such as maintenance personnel and facilities, and asset information systems, will need to continue, but also with developments as necessary to follow the changes in the assets themselves and in the related technology.

10.1.1 Factors in Continuity Planning

10.1.1.1 Financial

To maintain continuity in an asset fleet it is necessary to make financial provision for the purchase of new items as the fleet ages. If the fleet has an even spread of ages, disposals and acquisitions can occur at roughly even rates to keep the fleet size in balance. It is more likely, however, that most of the items in a fleet will have similar ages, and in this case we must make financial provision against the time when many replacements are due. The numbers purchased at any one time may involve considerations of available capital and economies of scale.

Ideally, we would like to know how much longer individual items will last before we need to replace them. But at the overall budgeting stage we need a process which will ensure that we have, at an aggregate level, the funding to provide the equipment that we need when we need it. In practice, we will take into account individual asset condition and service requirements when making a specific replacement decision.

10.1.1.2 Uniformity

There are advantages in having uniform fleets, so that we may wish to retire a particular equipment type all together and bring in the replacement type. This simplifies issues such as operations, training, spare parts provision, and technical support. We may also wish to use preferred suppliers so as to avoid too wide a spread of types for logistic support.

10.2 Asset Data

For planning purposes, data will be required. This will be held in an *Asset Register* and will be along the following lines:

- The types of assets in the fleet;
- The quantity of each type;
- Date of acquisition of each asset.

Also, we need an estimate of the useful life of each asset type. Ideally, this will be contained in the life cycle asset management plan for the asset. We may also take account of utilization data such as service hours of operation, or kilometers run in the case of vehicles.

10.3 Planning Terminology

The following terms are useful in the planning process. These are illustrated in Fig. 10.1.

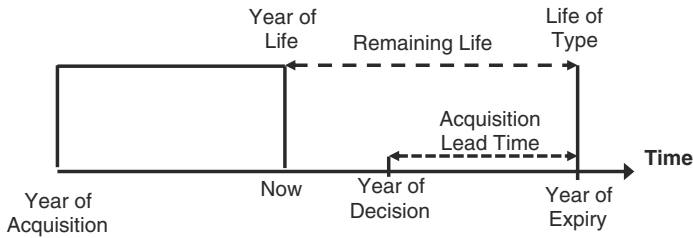

Fig. 10.1 Terms used in asset continuity planning

- *Year of Acquisition* is the year when the asset is acquired, usually also assumed to be the year when it starts its operational life. This should be recorded in the asset database.
- *Age or Year of Life* Measures of the age of an asset. Year of life is the age +1. Thus the first year of life is year 1, the second year is year 2, and so on.

$$\text{Year of Life} = \text{Current year} - \text{Year of Acquisition} + 1$$

For some assets, cumulative utilization may be a more effective measure than calendar time.

- *Life of Type* is the number of years for which a given type of item is assumed to last, for planning purposes. An alternative term is Estimated Useful Life. This concept is useful in planning for fleets of similar assets. For major assets, we may base our planning on individually assessed remaining lives. The Life of Type may vary with the application and with the environment. For asset fleets, it is advisable to assign a Life of Type for each type of asset. A guideline is given by the depreciation schedules published by tax authorities. This lists “effective lives” for a whole range of asset types. Decisions on specific item replacement can be made tactically in the short term, but it is unwise to rely on a purely tactical approach, as this may not give an adequate signal of financial requirements.
- *Remaining Life* is the number of years which we expect an asset to last from now.

$$\text{Remaining Life} = \text{Life of Type} - \text{Year of Life}$$

For major items the remaining life may be assessed individually.

- *Year of Expiry* is the calendar year in which an asset runs out of planned life. This is normally when it reaches its Life of Type.

$$\text{Year of Expiry} = \text{Current year} + \text{Life of Type} - \text{Year of Life}$$

Or we may estimate the Year of Expiry from the Remaining Life and the current year. It is the current year plus the Remaining Life.

$$\text{Year of Expiry} = \text{Current year} + \text{Remaining Life.}$$

- *Acquisition Lead Time* The time taken to plan and give effect to the acquisition of an item and bring it into service.

- *Year of Decision* The calendar year when an acquisition must be approved in order to make an item available when it is needed.

$$\text{Year of Decision} = \text{Year of Expiry} - \text{Acquisition Lead Time.}$$

10.4 Planning Schedules

In practice, asset continuity planning will involve many types of assets with varying ages and conditions. Planning schedules, usually in a spreadsheet format, can be used to assist in asset planning process. Useful schedules are:

- *Expiry Schedule* This shows how many items of a given range of assets are expected to reach their Year of Expiry by nominated calendar years.
- *Retirement Schedule* This is a schedule of planned retirement dates, which reflects decisions whereby some items retire at dates which differ from the expiry schedule. We should not lightly run over the Year of Expiry, but variations in timing may occur for reasons of cost and operational factors. If every item retired at its expiry date, the expiry and retirement schedules would be the same.
- *Decision Schedule* shows the types and numbers of items on which replacement decisions are needed in each year.
- *Acquisition and Cost Schedule* is derived from the preceding schedules.

10.5 Planning Schedules Example

The spreadsheet shown in Fig. 10.2 in an Excel format relates to an electricity distribution company. The company has a number of transformers of various types. It is planning a capital budget for transformer replacement. The types of transformers are designated H, K, and M in column A. Different numbers of transformers were purchased in different years in the past.

	A	B	C	D	E	F	G
1	Item Type	Year	1	2	3	4	5
2	H				10		
3	H						12
4	K				30		
5	K					24	
6	K						30
7	M			12			

Fig. 10.2 Transformer expiry schedule

10.5.1 Expiry Schedule

Figure 10.2 shows the expiry schedule for various cohorts of transformers. For example Row 2, Column E, shows that 10 transformers of type H will reach their expiry date in year 3 (i.e. 3 years from now). Similar entries are shown for the various cohorts of transformers.

10.5.2 Acquisition and Cost Schedule

The expiry schedule of Fig. 10.2 forms a basis for planning a replacement schedule in which some adjustment of the replacement pattern may take place in order to smooth both the replacement workload and the capital requirements. The smoothing process assumes that there will be some latitude for varying the expiry schedule based on asset condition. Technical knowledge of asset condition will be required to confirm whether this is practical. The replacement schedule is not shown separately, but is incorporated into the acquisition and cost schedule shown in Fig. 10.3.

In Fig. 10.3, Row 1 shows the years ahead, which normally would be shown as calendar years. The “Qty” column for each year shows the number of transformers of a given type which are budgeted for replacement in that year. The replacement quantities were initially derived from an expiry schedule, but the results have been smoothed during the planning process, so that, for example, the plan is to replace 11 type H transformers in each of years 3 and 4, rather than 10 in year 3 and 12 in year 5.

The “Cost” column shows the corresponding capital cost for replacement. For example, cell J3 shows a cost of \$8,250,000 to be budgeted for replacement of 11 type H transformers in Year 3. The final result from the acquisition and cost schedule will feed into the overall Capital Expenditure Budget.

10.5.3 Application of the Acquisition and Cost Schedule

The resulting acquisition and cost schedule forms a basis for budgeting and acquisition planning. The actual numbers of replacements may in practice vary from

	A	B	C	D	E	F	G	H	I	J	K	L	M	N	O
1	Item Type	Quantity	Renewal Cost,\$k	Year	1	1	2	2	3	3	4	4	5	5	Total
2					Qty	Cost	Qty	Cost	Qty	Cost	Qty	Cost	Qty	Cost	
3	H	10	750		0	0		0	11	8250		0		0	
4	H	12	750		0	0		0		0	11	8250		0	
5	K	30	345		0	0		0	28	9660		0		0	
6	K	24	345		0	0		0		0	28	9660		0	
7	K	30	345		0	0		0		0		0	28	9660	
8	M	12	1,250		0	0	12	15000		0		0		0	
9	Totals				0			15000		17910		17910		9660	60480

Fig. 10.3 Acquisition and cost schedule

those planned, but if estimates have been based on sound experience and judgment, the overall numbers of replacements will be approximately correct. The result will be effective management of the assets, which might otherwise have been allowed to run to failure with resulting loss of system reliability and safety.

10.6 Planning Example with Varying Needs

In the previous example, replacements were planned on a one-for-one basis, but in practice there may be variations as changes in capacity requirements result in the population being increased or decreased through time. The following example illustrates this.

A transportation company maintains a vehicle fleet.

Figure 10.4 shows data relating to a particular range of vehicles, for which the unit acquisition cost is \$800,000 and the unit disposal cost is \$100,000. These unit costs are shown in Row 2. The number of units needed in-service over the next 6 years is shown as “In-Service Need” in Row 4. This number includes a provision for local contingency holdings to cover emergencies. Initially there are 108 vehicles in-service including contingency, and 10 vehicles acquired but not currently deployed, giving a total of 118, shown as the year 1 “Un-augmented qty” at cell B6. Senior management has stated that the number of non-deployed vehicles is to be reduced.

The number of disposals of vehicles over the planning period has been estimated, allowing for aging and condition of the existing items. This is shown in Row 5 as “Disposals end of year”. The problem is to plan the purchase of new vehicles over the 7-year planning period and to estimate the financial capital requirements.

10.6.1 Preplan Gap Analysis

The first step is to carry out a preplan gap analysis. A preplan gap analysis is an analysis of the situation before we plan any acquisitions or other changes. It represents how the situation would unfold if we do nothing. In the example, the gap

	A	B	C	D	E	F	G	H
1	Capacity Planning Example - DATA							
2	Unit Costs \$M	Acquisition		0.8	Disposal		0.1	
3	Year	1	2	3	4	5	6	7
4	In-Service Need	108	108	110	112	114	117	120
5	Disposals end of year	2	12	14	10	5	1	1
6	Un-augmented qty	118						

Fig. 10.4 Vehicle planning data

	A	B	C	D	E	F	G	H
1	Capacity Planning Example - PRE-PLAN GAP ANALYSIS							
2	Unit Costs \$M	Acquisition		0.8	Disposal		0.1	
3	Year	1	2	3	4	5	6	7
4	In-Service Need	108	108	110	112	114	117	120
5	Disposals end of year	2	12	14	10	5	1	1
6	Un-augmented qty	118	116	104	90	80	75	74
7	Pre-plan Gap	-10	-8	6	22	34	42	46

Fig. 10.5 Gap analysis calculation

between the in-service need and the quantity available after disposals is the *pre-plan gap* this represents the situation before we plan any acquisitions.

The calculations are shown in Fig. 10.5. We first calculate the un-augmented capacity by subtracting the disposals (Row 5) progressively from the initial quantity available (cell B6).

Figure 10.5 Row 6 shows the result. We then calculate the preplan gap by subtracting the un-augmented capacity (Row 6) from the need (Row 4). Row 7 shows the result.

Figure 10.6 shows the preplan gap as a graph, based on the needs (Row 4) and the un-augmented qty available (Row 6). The space between the two lines is the gap, and can be negative (representing a surplus) or positive (representing a shortage). The preplan gap result can assist with acquisition planning. In the example, the minimum total number of vehicles to be acquired over the planning horizon is 46, given in cell H7 of Fig. 10.5. This result can assist us in deciding on an acquisition strategy, for example, we may decide to develop a purchase plan covering all 46 vehicles, from our preferred potential suppliers. We also see that there will not be a positive gap until year 3, and this tells us that we have some lead time in hand.

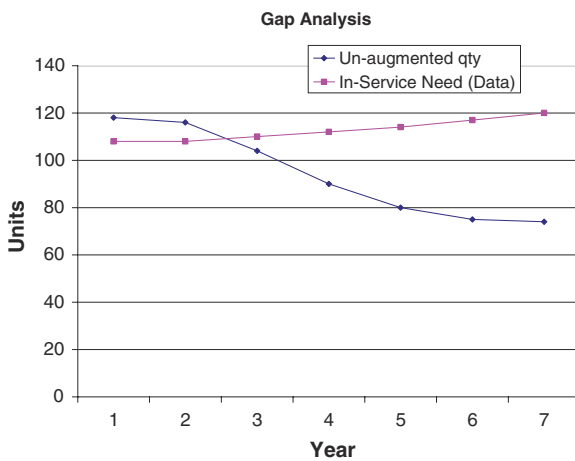

Fig. 10.6 Gap analysis graph

10.6.2 Creating the Purchase Plan

The process for creating the purchase plan for each year across the horizon is as follows. The process is illustrated in Fig. 10.7 and summarized algebraically at the end of this section.

- Calculate the quantity-before-purchase, that is, the fleet quantity available in the current year before more items are purchased (Row 9 and Eq. 8.3);
- Calculate the gap-before-purchase, this gives the minimum number to be purchased to cover the gap (Row 10 and Eq. 8.4);
- Create a purchase plan quantity (Row 11, BOY = Beginning of Year) which may vary from the minimum purchases;
- Calculate the fleet quantity-after-purchase, (Row 12 and Eq. 8.5);
- Calculate the cost (Row 17).

10.6.2.1 Planning Steps

The steps in the example are as follows: For year 1 we calculate the quantity-before-purchase and the gap-before-purchase. In year 1, the gap-before-purchase is negative so we decide to make no purchases. In year 2, the gap is also negative so again we make no purchases. In year 3, the quantity-before purchase, is 104 but the In-Service Need is 110, so we get a gap-before-purchase of 6. These vehicles are normally purchased in multiple quantities of about 10. The reason behind the minimum lot size is that we want to avoid having too fragmented a set of assets and also to achieve economies of scale in purchasing. Since our policy is to

	A	B	C	D	E	F	G	H
1	Capacity Planning Example PLANNING: ROWS 9 to 17							
2	Unit Costs \$M	Acquisition		0.8	Disposal		-0.1	
3	Year	1	2	3	4	5	6	7
4	In-Service Need	108	108	110	112	114	117	120
5	Disposals end of year	2	12	14	10	5	1	1
6	Un-augmented qty	118	116	104	90	80	75	74
7	Pre-plan Gap	-10	-8	6	22	34	42	46
8								
9	Qty before purchase	118	116	104	100	102	109	118
10	Gap before purchase	-10	-8	6	12	12	8	2
11	Purchase Plan BOY	0	0	10	12	12	10	10
12	Qty after purchase	118	116	114	112	114	119	128
13								
14	Cumul Purchased	0	0	10	22	34	44	54
15	Planned excess	10	8	4	0	0	2	8
16								
17	Capital Reqt \$M		0.2	9.2	11	10.6	8.5	8.1

Fig. 10.7 Asset purchase planning

Fig. 10.8 Vehicle purchase capital requirements graph

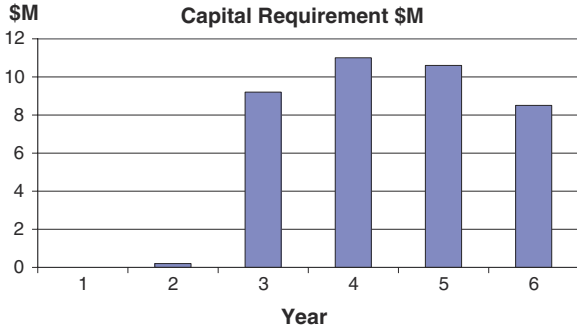

purchase in lots of at least 10, we plan to purchase 10. The quantity-after-purchase then becomes 114, shown at cell D12.

For year 4, the quantity-before-purchase is found by subtracting the disposals at the end of year 3, and the gap-before-purchase is calculated. This is 12 as shown at cell E10. We then make a purchase plan decision for year 4, and in the example this is for 12 items. The calculations then continue in the same way, with purchase plan decisions being made for each year. As we proceed, the spreadsheet calculates the capital requirement based on the numbers of purchases and disposals and their costs. A graph of the capital requirements year by year is shown in Fig. 10.8.

The spreadsheet format allows us to model a range of data assumptions and plans and to present the corresponding tabular and graphical results.

10.6.2.2 Planning Formulas

The planning process is summarized algebraically as follows.

Let

- i* year number
- N* in-service need (Row 4)
- D* disposal quantity at end of year (Row 5)
- U(i)* un-augmented quantity (Row 6)
- X(i)* preplan gap (Row 7)
- Q* fleet quantity-before-purchase (Row 9)
- G* gap-before-purchase (Row 10)
- P* purchase quantity (Row 11)
- R* fleet quantity-after-purchase (Row 12)

Then for the preplan gap analysis:

$$U(i) = U(i - 1) - D(i) \tag{10.1}$$

$$X(i) = N(i) - U(i) \tag{10.2}$$

And for the purchase planning stage:

$$Q(i) = Q(i - 1) + P(i - 1) - D(i - 1) \quad (10.3)$$

$$G(i) = N(i) - Q(i) \quad (10.4)$$

$$R(i) = Q(i) + P(i) \quad (10.5)$$

10.7 Capability Continuity Planning

The process described in this chapter represents a basic approach to the planning of prime equipment requirements and in practice additional work will be required in planning for the continuity of the total capability involved in the sustainment of the assets. Having established the prime asset requirement we continue to plan for the related elements of the capability, and this may cause feedback into the prime equipment plan. In practice, a number of interrelated spreadsheets or similar planning systems will be needed.

10.8 Columnar Format

The analysis can also be carried out in the style indicated by Fig. 10.9. This lists the assets by type and age, and shows the *life of type* or estimated useful life of each group. From this the *year of expiry*, that is, the year by which replacement is needed, can be calculated. In Fig. 10.9 this is shown in relation to “Now” but in practice an actual calendar year would be shown. The acquisition lead time is then entered and we then calculate the year of decision. The *year of decision* is the year in which we must make a decision about replacing the assets in order to acquire their replacements by their year of expiry. The year-of-decision calculation gives an indication of the urgency of the development process.

The analysis proceeds to an asset retirement schedule as illustrated in Fig. 10.10.

Item Type (1)	Qty (2)	Year of Life, (3)	Life of Type, (4)	Year of Expiry, (5)=Now+(4)-(3)	Acquisition Lead Time, years (6)	Year of Decision (7)=(5)-(6)
A	10	13	15	Now+2	2	Now
A	12	11	15	Now+4	2	Now+2
B	30	7	10	Now+3	3	Now
C	24	37	40	Now+3	3	Now
C	30	36	40	Now+4	3	Now+1
D	12	15	15	Now	2	Now-2

Fig. 10.9 Determining year of expiry and year of decision

Item Type	Now	Now+1	Now+2	Now+3	Now+4
A	0	0	10	0	12
B	0	0	0	30	0
C	0	0	0	24	30
D	12	0	0	0	0
E	0	3	15	0	6
F	2	7	3	2	0

Fig. 10.10 Retirement schedule, numbers retiring each year

10.9 Exercises

10.9.1 Continuity Planning

A fleet of five specialized vehicles used in road maintenance was purchased 4 years ago. Their Life of Type is 10 years. Because they are imported and then adapted to local conditions, their acquisition lead time is 2 years. Calculate the following:

- The year of life of the fleet;
- Their remaining life;
- Their year of expiry;
- Their year of decision;
- The capital expenditure plan for continuity of the fleet, given a cost of \$700,000 2 years prior to entry into service and \$300,000 1 year prior to entry into service.

10.9.2 Vehicle Fleet Capacity Exercise

A company currently has 10 trucks. Trucks are sold when they become 7-years old. A forecast of the required number of vehicles to be in-service, and of the projected numbers of disposals year by year, is shown in Fig. 10.11.

Year	1	2	3	4	5	6
Vehicles Required In-Service	10	12	10	12	12	13
Disposals end of year	1	0	2	1	2	1

Fig. 10.11 Projected vehicle demand and disposals

New trucks cost \$200,000. Old ones are sold for \$15,000. The company policy is to own sufficient trucks to cover “base load” requirements. Shortages can be made up by leasing at \$50,000 per truck per year. Capital rationing limits purchases to at most three trucks in any year.

Determine a suitable purchasing and hiring plan. Estimate the cost year by year and calculate the net present value of costs.

10.10 Exercise Solutions

10.10.1 Continuity Planning Solution

- Year of Life = Current Year – Year of Acquisition + 1 = 4 + 1 = 5.
- Remaining Life = Life of Type – Year of Life = 10 – 5 = 5 years (beyond current year).
- Year of Expiry = Current Year (say NOW) + Remaining Life = NOW + 5.
- Year of Decision = Year of Expiry – Acquisition Lead Time = NOW + 5 – 2 = NOW + 3.
- Assuming entry into service at start of NOW + 6, CAPEX in NOW + 4 is $5 \times \$700,000 = \3.5 million and in NOW + 5 is $5 \times \$300,000 = \1.5 million.

10.10.2 Vehicle Fleet Capacity Exercise

The solution can be developed using the template shown in Table 10.1 Vehicle Fleet Planning Template. BOY means Beginning of Year and EOY means End of Year.

Table 10.1 Vehicle fleet planning template

1. Year, i	1	2	3	4	5	6
2. Vehicles reqd BOY	10					
3. Disposals EOY	1					
4. Number owned BOY before purchase = Row 2 (i – 1) – Row 3 (i – 1)	10					
5. BOY shortage (+) or surplus (–) = Row 2 – Row 4	0					
6. Purchase plan BOY	0					
7. Number owned BOY after purchase = Row 4 + Row 6	10					
8. Lease reqt BOY = Row 2 – Row 7						
9. Lease cost = Row 8 \times \$50 k						
10. Capital cost = Row 6 \times \$200 k – Row 3 \times \$15 k	–15					
11. Total \$k	–15					

Table 10.2 Vehicle fleet planning solution

1. Year, i	1	2	3	4	5	6
2. Vehicles reqd BOY	10	12	10	12	12	13
3. Disposals EOY	1	0	2	1	2	1
4. Number owned BOY before purchase = Row 2 (i - 1) - Row 3 (i - 1)	10	9	10	8	10	10
5. BOY shortage (+) or surplus (-) Row 2 - Row 4	0	3	0	4	2	3
6. Purchase plan BOY	0	1	0	3	2	2
7. Number owned BOY after purchase = Row 4 + Row 6	10	10	10	11	12	12
8. Lease reqt BOY = Row 2 - Row 7	0	2	0	1	0	1
9. Lease cost = Row 8 \times \$50 k	0	100	0	50	0	50
10. Capital cost = Row 6 \times \$200 k - Row 3 \times \$15 k	-15	200	-30	585	370	385
11. Total cost \$k	-15	300	-30	635	370	435

Notes

- A rolling plan will be reviewed annually
- Capital costs are smoother if approximately the same number of vehicles bought each year, but this can have the disadvantage that the fleet is made up of many different models
- Leasing is usually more expensive than owning in terms of costs per vehicle leased, but...
- Leasing costs are an expense which is tax deductible in the current year
- Leasing gives more flexibility in responding to changes in demand, particularly downturns; there is more downside liquidity
- If demand is up, revenue will be up and the extra cost of leasing will be affordable

The analysis can be carried out using the following steps:

- Calculate the number of vehicles which will be owned at the end of the year after disposals, but before purchases. Row 4.
- Compare this with the number required next year, to check for a potential shortage. Row 5.
- Decide how many to buy, if any, make up the rest of any requirement with leasing. Row 6, Row 8.
- Calculate costs. Rows 9-11.

Microsoft Excel - CapacityPlan MainBud

File Edit View Insert Format Tools Data Window Help

B18 =NPV(10%,B17:H17)

	A	B	C	D	E	F	G	H
1	Vehicle Fleet Capacity Planning							
2	Lease cost \$k (Data)	50						
3	Unit Cost \$k (Data)	200						
4	Disposal value \$k(Data)	15						
5	Year (Data)	1	2	3	4	5	6	7
6	Units Required (Data)	10	12	10	12	12	13	13
7	Disposals EOY (Data)	1	0	2	1	2	1	1
8	BOY before purch. No. owned (Data yr 1)	10	9	10	8	10	10	11
9	BOY before purch. Shortage	0	3	0	4	2	3	2
10	Purchase Plan BOY (Data)	0	1	0	3	2	2	1
11	BOY after purch. No. owned	10	10	10	11	12	12	12
12	No Leased	0	2	0	1	0	1	1
13								
14	Acquisition cost	0	200	0	600	400	400	200
15	Lease cost	0	100	0	50	0	50	50
16	Disposal net cost	-15	0	-30	-15	-30	-15	-15
17	Financial Reqt \$k	-15	300	-30	635	370	435	235
18	NPV \$k							\$1,241

Fig. 10.12 Vehicle fleet planning—excel solution

The results are shown in Table 10.2 Vehicle fleet planning solution and Fig. 10.12.

Chapter 11

Management of In-Service Assets

Abstract The aim of this chapter is to outline the organization and functions involved in providing for the management of in-service assets over their lifetime, and to describe the formation of asset management plans for in-service assets. *Outcomes* After reading this chapter you will be aware of the types of activities needed for management of the deployed assets of the organization. This includes the need for having an integrated overview of the deployed assets and of the planning needed to provide support and sustainment of the “fleet” as a whole on a through life basis. You will have seen how asset management plans are developed for an in-service asset fleet as a whole for given planning horizons. You will also be aware of the need for configuration management for the fleet.

11.1 In-Service Assets

In-service assets are those currently deployed for use within the organization. In-service assets may be referred to as a “fleet,” regardless of the type of asset. In this chapter the organization and functions involved in providing for the management of in-service assets will be outlined. The development of asset management plans will be considered, leading to the formation of a consolidated asset management plan which forms a basis for budgeting for the fleet.

11.2 In-Service Support Aims

In-service asset support involves ensuring that deployed assets are able to deliver their intended function over their required life. The objectives are to achieve business goals for the deployed assets by providing productive capacity, availability, quality, safety, and meeting regulatory standards. Well directed support policies

and matching levels of expenditure, including maintenance, will enable the assets to effectively support business goals and will also save money by avoiding premature replacement and reducing the need for additional equipment.

The management of in-service support for any particular capability is based on the logistic support planning undertaken at the acquisition stage, but involves integrating the activities across the range of deployed assets, and dealing with the current circumstances as they evolve over the life of the assets.

11.3 In-Service Support Activities

The following activities are required to support the deployed assets.

Asset continuity planning and management For any particular range of capability the asset support manager will maintain information on the asset capability required, the current deployment of assets; surplus or shortages in asset inventory levels; equipment condition; configuration and modification status; logistic support status; remaining useful life and requirements and plans for deeper maintenance and renewal. This information will be used as a basis for decisions relating to equipment deployment, procurement of spares and replacements, and equipment maintenance policy particularly in regard to overhauls or deeper maintenance, renewal, and disposals.

Maintenance This is a basic requirement which is separate from the function of asset management groups. It may come under the overall control of a Chief Asset Manager. Close liaison and regular feedback between asset management and maintenance is important for the effective delivery of asset performance.

Facilities and resources planning Planning of facilities for maintenance and logistic support across the organization and over the life of the deployed equipment. This requires a maintenance staffing plan, maintenance training plan; balancing of workloads of maintenance staff.

Asset Information Systems Application, development, and support for the asset management and maintenance applications.

Spares and consumables management In the acquisition phase there will normally be an initial buy of equipment, consumables, spares, and rotables. Once the equipment is in service the continued acquisition of consumables, spares, and rotables becomes part of the in-service asset management function. This includes monitoring and controlling stock levels, including such issues as setting reorder controls, establishing reserves and repair pools, monitoring procurement contracts, and creating new contracts as necessary. It will be necessary to keep up-to-date with technical changes and with changes in supplier and support services.

Regulatory issues awareness and response Awareness of and response to needs relating to regulatory issues such as safety, health, environment, and technical properties of the assets. Statutory requirements for inspections and maintenance activities.

Risk analysis and risk management

Technical developments monitoring and response Assessment of the significance of technical developments to operations and asset requirements. Application of technical developments in maintenance, e.g., condition monitoring and proactive asset care rather than a breakdown approach. Care must be taken to ensure that changes are fully substantiated by technically qualified and authorized persons before changes are made.

Development implementation decisions

Technical improvements or modifications will come along from time to time. An issue is how any particular change should be implemented. Factors to be considered are:

- If essential for operational, safety or regulatory reasons, prompt implementation will be required.
- If significantly advantageous but not essential, a phased implementation will be suitable.
- If only moderately advantageous then the change may be effected as and when it becomes convenient to do so.

A policy decision categorizing the change and setting out implementation rules will be needed.

Change Management Whenever changes are implemented, a change management process should be applied, so as to ensure that changes are assessed, managed, effectively controlled and communicated. The aim is to ensure maximum benefit is achieved from the proposed changes and that there are no adverse effects to health and safety, no damage to plant or equipment, legislative requirements are upheld and negative impacts on performance are avoided.

Configuration management Maintaining records of the configuration status of in-service equipment. Input into modification decisions, planning upgrades including making equipment available, timing of work and facilities and contract management.

Deeper maintenance awareness and planning Awareness of the status of equipment in regard to deeper maintenance needs. Planning for deeper maintenance, for example, planning site shutdowns across the organization, so as to minimize impact on business goals and to be consistent with maintenance resource availability. Arranging deeper maintenance contracts.

Outsourcing Strategy and contracts for maintenance and related support activities.

Replacement analysis Reviewing the condition and supportability of equipment, life cycle cost review and management, input to economic life decisions and to repair/replace strategy.

Continuous Improvement Continuous Improvement means continually seeking to make improvements in procedures and processes. The accumulation of small improvements can, over time, achieve substantial benefits. Care must be taken to

ensure that changes are fully substantiated by technically qualified and authorized persons before changes are made. Pilot studies and a formal review of possible consequences are recommended before a proposed improvement is adopted.

Disposal

Planning and Budgeting for all of the above.

11.4 Organization for In-Service Support

The structure required for the organization of in-service asset support is shown in Figs. 2.4 and 11.1 where we see in-service asset support as part of the activity of each asset management group.

The in-service asset support group manages at the strategic level, the activities involved in logistic and technical aspects of deployed assets. The detailed activity of maintenance will be carried out by maintenance departments and workshops which may be part of an operating division or may come directly under the asset management function, or may be outsourced. Engineering, finance, and legal staff work with the in-service support personnel to provide integrated management of the support functions. In a smaller or decentralized organization, in-service asset management may combine with maintenance management roles.

Staff in the in-service support group will be drawn from experienced maintainers, experienced operations personnel, technical or engineering support personnel, particularly those familiar with the relevant equipment.

Fig. 11.1 Organization for management of in-service assets

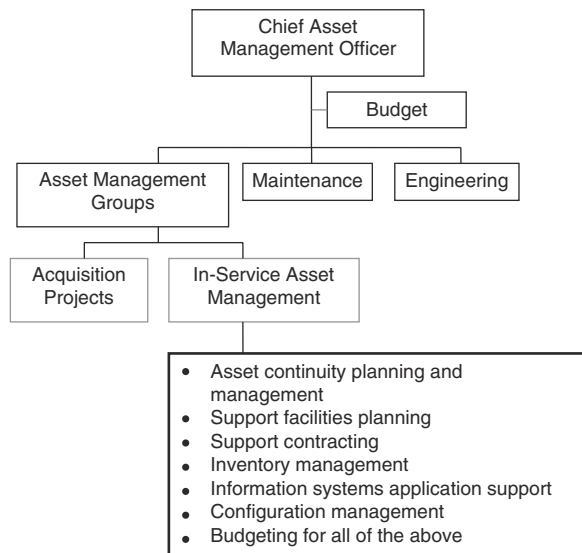

11.5 Engineering and Technical Services

The role of engineering and technical services is to develop, maintain, and apply technical knowledge of the main areas of activity. They deal with the more technical aspects of equipment operation and sustainment and provide a resource which can respond to technical problems which cannot be resolved by line managers and maintainers. They maintain contacts with original equipment manufacturers (OEMs), with local support services and with suppliers. They maintain knowledge of technical developments, including condition monitoring techniques. They carry out studies of technical problems leading to improvements in reliability, maintainability, and availability. Depending on organizational size and dispersal, they may be centralized to a greater or lesser extent with company asset management. Technical changes to assets, operations, or maintenance regimes must be cleared by the appropriate technical authority before implementation.

11.6 Asset Management Plans

11.6.1 ISO 55000 Definition and Requirements

The term “Asset Management Plan” is defined in ISO 55000 as:

“documented information that specifies the activities, resources and timescales required for an individual asset or grouping of assets to achieve the organization’s asset management objectives.”¹

Thus, ISO 55000 defines an Asset Management Plan as referring to a specific asset or group of assets, and involving specifying:

- Activities
- Resources
- Timescales.

ISO 55001 states that “the organization shall establish, document and maintain asset management plans...”² Thus asset management plans are a required feature for compliance with the standard.

An *asset management plan* as defined in ISO 55000 is a conventional plan for managing an asset or group of assets. This is *different from* the ISO 55000 definition of the *Strategic Asset Management Plan (SAMP)*, despite the similarity in the name. The SAMP is discussed in a later chapter.

¹ ISO 55000 at Clause 3.3.3.

² ISO 55001 at Clause 6.2.2: “The organization shall establish...asset management plans...”.

11.6.2 Life Cycle Asset Management Plan

There are two very distinct types of asset management plans which arise in practice. The first is the Life Cycle Asset Management Plan which was discussed in the chapter on Life Cycle Costing. A Life Cycle Asset Management Plan is a plan formed by identifying the maintenance, repair, and overhaul activities for the particular asset type.

For example, for an aero engine of a given type, we plan the series of maintenance actions required, based on its flying hours from new, including when the engine would require heavy maintenance and eventual replacement. The plan would also tell us, the facilities that were required and the spares and labor needed at various stages for engines of this particular type.

11.6.3 Planning-Period Asset Management Plan

A Planning-Period Asset Management Plan is a plan that is for the management of a whole portfolio of assets over a given time period, such as 1, 5, or 10 years. This is the type of plan that we need for developing budget proposals for the management of our in-service assets.

In the aero engine case, the planning-period asset management plan considers all the aero engines of a given type, and possibly of several types where their need for resources interacts. The planning-period plan draws information from the Life Cycle Asset Management Plans of individual engines or engine types to create a plan for a given time period for the portfolio as a whole.

To give another example, suppose that we are managing a vehicle fleet. The Life Cycle Asset Management Plans for a given type of vehicle are the plans for vehicles of that type, usually developed from the manufacturers' specifications, showing their servicing requirements, augmented by estimates for repairs, assembly or component replacements, and so on. The Planning-Period Asset Management Plan is the plan for a given period of time for the whole facility which involves a mixture of vehicles of various types of varying numbers, varying ages, and with varying demands.

The Planning-Period Asset Management Plans form the basis for budgetary proposals for CAPEX and OPEX to provide ongoing support for sustainment of the fleet. The Planning-Period Asset Management Plans should align with the Life Cycle Asset Management plans for individual assets, and with the business operating requirements.

11.6.4 Planning Overview

In this chapter we consider Planning-Period Asset Management Plans. We shall assume that Life Cycle Asset Management Plans are available.

Asset management planning focuses on the alignment of assets with the requirements of an organization to enable maximum return of value. The aim is to produce plans over given time horizons, which are achievable from all perspectives, that is, operationally, financially, and in terms of the required assets and supporting services. This involves the integration of:

- operational plans,
- financial plans and
- asset management plans.

The asset management plans will take into account the life cycle activities and logistic support needed to sustain the assets. The planning process will involve the creation of asset management plans for individual assets or groups of assets which will be coordinated with operational plans and the financial plans.

Plans for individual assets or groups of assets will feed up into a *consolidated asset management plan* which typically will involve some prioritization and selection from the lower level plans. Figure 11.2 illustrates the process in a schematic way. The consolidated asset management plan is integrated with the operational plan and the financial plan and budget at business level to produce a coordinated set of plans for the organization.

Inputs to the asset management planning process are both “Top Down” and “Bottom Up.” Top-Down inputs will be in response to changes from external sources, such as market demand, product changes, technical changes, or changes in the business structure or strategy. These will directly affect the business plan and this in turn will affect the asset management plans. Bottom-Up inputs will come from the need to replace or upgrade equipment, changes in service level expectations or technical change.

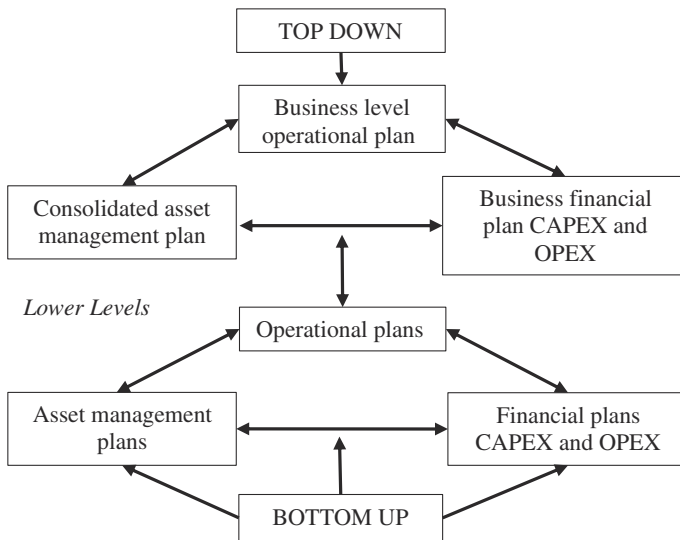

Fig. 11.2 Business and asset planning process overview

It is important that the asset management plans respond to all these inputs. The resulting changes in the plans will lead to financial proposals to support the necessary physical changes. There must then be an effective business-level response, so that funding is available, and is suitably delegated, in order to keep the assets in step with the business strategy.

11.6.5 Asset Management Plan Inputs

The elements that go into making an asset management plan for a group of assets can be summarized as follows:

- Identification of the assets planned for in the plan (includes asset register references)
- Outline of business objectives and plans for which the assets are required
- Identification of responsibilities in relation to the plan
- Asset criticality, priority
- Forecast demand
- Demand management
- Service levels planned and current actual
- Maintenance activities including overhaul or refurbishment
- Remaining lives
- Renewal plan
- Support services, e.g., spares, maintenance facilities, information systems
- Risk and contingency
- Communication
- Asset values
- Configuration management
- Change management.

11.6.6 Planning Considerations

Asset management plans will be developed for major assets or groups of assets. The plans combine operational, capital, and maintenance aspects of the management of the assets and form the basis for input into the CAPEX and OPEX budgets. For any given major asset or asset group, the asset management plan will cover the following points:

- Identify and list the relevant assets, any related projects (e.g., existing acquisitions or disposals in progress) and specifically related systems and facilities.
- Summarize the current role of, need for and criticality of the assets including operational and financial significance.
- Report on the current status of the asset in terms of condition, performance, functionality, regulatory compliance, and maintenance cost (including reliability, availability, maintenance backlog) of the asset.

- Compare the status of the asset with current service standards and operational and regulatory requirements.
- Predict the status and performance over the planning period.
- Identify where the asset is performing below the required standard now, or at projected times in the planning period.
- Identify actions required to maintain the assets to the required standard over the planning period. Actions involved may be: Do Nothing, Replace, Refurbish, Modify, Augment.
- Preliminary review, financial analysis, and business case.
- Take the results for this asset or asset group forward for consideration in the Consolidated Asset Management Plan.

11.6.7 Consolidated Asset Management Plan

A consolidated asset management plan is plan which consolidates information from individual asset management plans and applies to a stated time period. The consolidation process may involve some coordination and prioritization. The creation of a Consolidated Asset Management Plan is a step in developing the financial budget needed to support the assets and the asset management system.

Having developed plans for individual major assets and groups of assets, we take these forward for consideration in the consolidated asset management plan. This plan, as the name suggests, consolidates the requirements from the individual asset management plans into a single plan across the business. The actions arising from the individual plans are now treated as follows:

- Bring forward actions from individual asset management plans
- Review actions from integrated standpoint
- Prioritize actions
- Financial analysis and business case
- Final approval process
- Create project plans for acquisitions, refurbishments, disposal, etc.

11.6.8 Plan Summary

The resulting consolidated plan consists of the follow main elements.

- Schedule of major maintenance activities, e.g., shutdowns or refurbishments.
- Changes in resource allocations by location, quantity, and time.
- Schedule of proposed acquisitions with timings.
- Schedule of proposed disposals with timings.
- CAPEX and OPEX financial plan or proposal with business case.
- Allocation of responsibilities in relation to the plan.

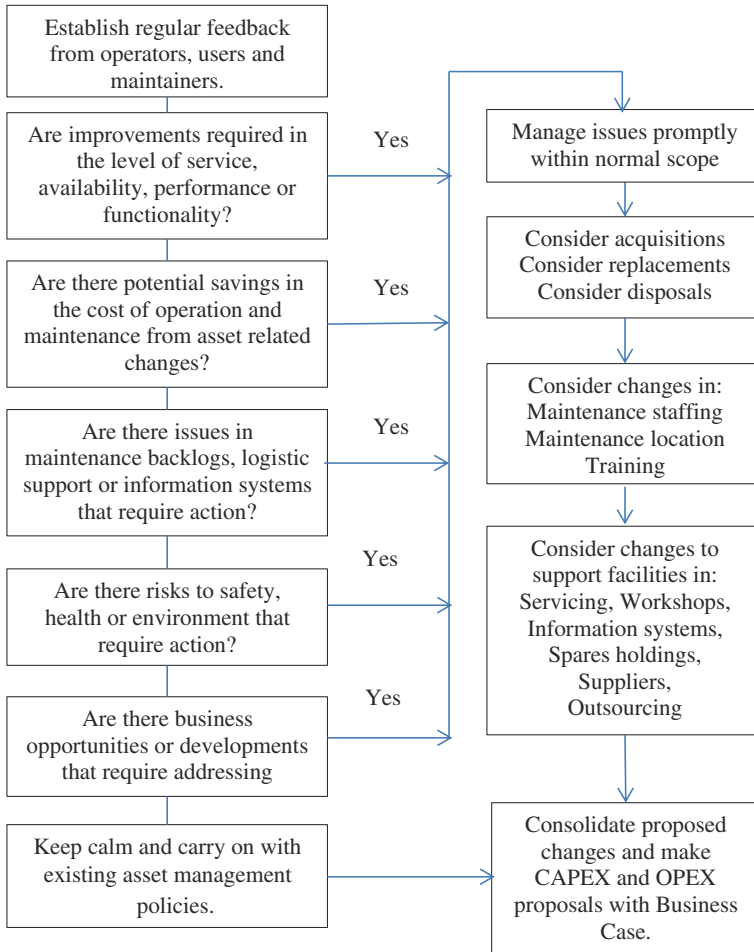

Fig. 11.3 In-service asset management, planning, and budgeting

The consolidated asset management plan goes forward as part of the budgeting process. This process is summarized in Fig. 11.3.

11.7 Time Period (e.g., 5 Year) Asset Management Plan

11.7.1 Introduction

There is a requirement within organizations for a document which provides an overview of the current and projected asset plan over various time periods, e.g., a 5- or 10 year horizon. This document is not a budget submission but is based

on a combination of the agreed or projected budget commitments over the planning period. This document outlines the current assets and their status, the drivers, external and internal, which influence current asset requirements, and the asset plans and expenditures for given future planning periods. I shall refer to this document as the 5 Year Asset Management Plan, although variations on this title may be preferred or already exist in organizations, and the actual planning horizon can be longer or shorter. This document is of interest to a range of stakeholders, including senior management, asset managers, and managers in areas outside of the asset management team.

11.7.2 Relationship to the SAMP

The 5 year Asset Management Plan is an asset management plan in the sense defined in ISO55000.³ That is to say, it focusses on activities, resources, and time-scales. The SAMP,⁴ which is discussed in a later chapter, by contrast, focusses on “how to” information on the asset management system as a whole. The SAMP is particularly relevant for ISO55000 accreditation as it describes how the broad requirements of the standard are to be met. The SAMP and the 5 Year Asset Management Plan will have some material in common. The extent to which they are merged or linked into a single document is at the discretion of the organization.

11.7.3 Role of the 5 Year Asset Management Plan

The 5 year Asset Management Plan serves the following purposes:

- Informs senior management and other stakeholders of the current role and status of assets
- Informs senior management and other stakeholders of the current role and status of asset management and the systems used to support it
- Summarizes asset management plans for both assets and support services over the designated planning horizon
- Links the current business plans and asset management plans
- Links the asset plans to the CAPEX and OPEX budgets.

³ ISO 55000 at Clause 3.3.3.

⁴ Defined at ISO 55000 Clause 3.3.2.

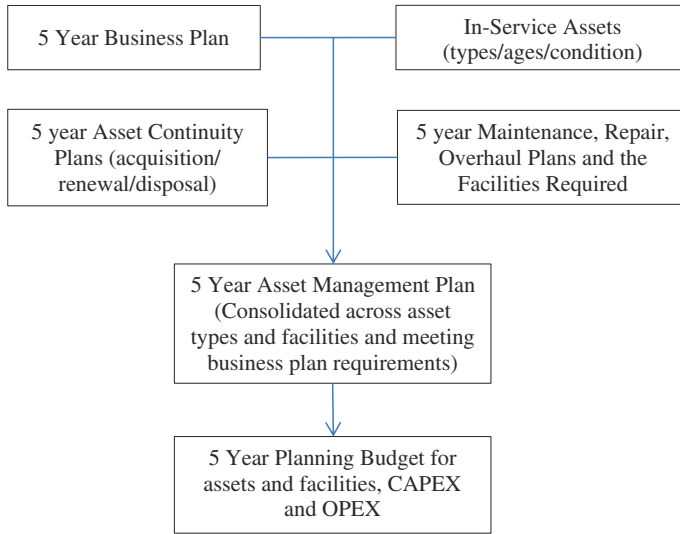

Fig. 11.4 Development of the 5 year asset management plan

11.7.4 Development of the 5 Year Plan

Development follows the outline in Fig. 11.4.

11.7.5 Outline Contents of a 5 Year Asset Management Plan

An outline of the contents of a 5 year Asset Management Plan document is as follows:

1. Title
2. Foreword
3. Executive Summary
4. Introduction
 - 4.1. The Organization and its Context
 - 4.2. Objectives
 - 4.3. Stakeholders
 - 4.4. Leadership
 - 4.5. Policy, Vision, and Mission Statements
 - 4.6. Organizational Diagram
 - 4.7. Organizational Roles
 - 4.8. Regulatory Environment

5. Planning Process

- 5.1. Purpose of Plan
- 5.2. 5 Year Asset Management Plan Development Framework

6. Asset Description

- 6.1. Key Asset Summary
- 6.2. Maps, Schematic Diagrams, Flowcharts
- 6.3. Current Utilization
- 6.4. Asset Age and Condition Summaries by Asset Type

7. Asset Management Drivers

- 7.1. Strategic Drivers
- 7.2. Market Drivers
- 7.3. Specific Demand Drivers
- 7.4. Technological Factors
- 7.5. Demand Management

8. Levels of Service

- 8.1. Definition of Levels
- 8.2. Targets
- 8.3. Performance
- 8.4. Service level Plans and Strategies

9. Plans

- 9.1. Capacity
- 9.2. Availability
- 9.3. Maintenance and logistic facilities and equipment
- 9.4. Information systems, procedures, analysis
- 9.5. Risk, emergency response
- 9.6. Safety
- 9.7. Environment
- 9.8. Monitoring and Improvement

10. Financial Summary

- 10.1. Developments
- 10.2. Continuity
- 10.3. Maintenance
- 10.4. Asset Disposal
- 10.5. Projected Budget for Relevant Planning Periods

11. Appendices

- 11.1. Definitions
- 11.2. Abbreviations and acronyms
- 11.3. References.

11.8 Configuration Management⁵

Configuration management involves keeping track of technical details of the assets in a fleet in regard to all the factors which are important for operation and maintenance. It provides information for operators, maintainers, and engineers in dealing with activities relating to the assets. A configuration management plan should be established as part of the logistic support plan. If configuration management is lacking, an organization can easily find itself with an unknown mixture of equipment configurations, creating problems for operations, maintenance, and logistic support. Configuration management is important in relation to change management.

11.8.1 Configuration Management Example

Consider an organization which operates a large fleet of buses, perhaps as many as 1,000. Buses will have been bought at different times and will have different specifications. Configuration management involves keeping track of the details of the buses in the fleet in regard to all the factors which are important for bus operation and maintenance. The operators of the buses will need to have up-to-date information for each bus regarding such factors as: the number of seats, standard of comfort, audio or video equipment on board. Older buses may be subject to different regulatory design rules from newer buses. Some buses may have been upgraded, for example, by adding seat belts, but this may not apply to all buses which are otherwise similar. Maintenance personnel will require access to drawings and specifications for maintenance and repair tasks.

11.8.2 Configuration Description

The configuration description of a capability is a description, usually held in a computer database, which gives details of the configuration. The fields in the configuration description need to be defined as a preliminary to creating the configuration descriptions for the relevant assets.

Configuration management, including drawings and all relevant details, is required for:

- Land,
- Buildings,
- Machinery and equipment,

⁵ ISO 10007 Configuration Management.

- Water, electricity and gas supply,
- Drainage,
- Sewerage,
- Roads,
- Bridges,
- Embankments and civil works,
- Piping and instrumentation in chemical, oil, and gas plant,
- Software and electronic systems installed in or used with assets.

11.8.3 Configuration Management Process

The configuration management process involves creating the configuration description, coordinating, controlling, approving and recording configuration changes, and auditing physical configurations to ensure that the necessary capability is deliverable. Without tight configuration management, capability can be lost due to the loss of essential components or features, through shifting priorities and lack of awareness of the capability requirements.

11.8.4 Configuration Change Control

Configuration change control involves the analysis of proposed changes, combining technical and business viewpoints, and the application of a formal procedure for the approval of agreed changes. Changes need to be evaluated in regard to their functional and logistic implications before being implemented. Records of actual configurations are made and changes are recorded as they are implemented. Awareness of and adherence to design and construction standards is an important factor in the approval of configuration changes. The configuration change control process should ensure that related technical information is updated as changes occur. Configuration audits should be carried out to ensure that configuration records are being maintained.

11.9 Exercises

11.9.1 Self-Assessment Quiz 9.1

1. What are “in-service assets”?
2. Name four activities involved in the management of in-service assets.
3. What is the difference between a life cycle asset management plan and a planning-period asset management plan?

4. What top-down factors can influence the management plan for in-service assets?
5. What bottom-up factors can influence the management plan for in-service assets?
6. Identify four reasons for having a time period (e.g., 5 year) asset management plan

11.9.2 Configuration Management Exercise

1. What is configuration management?
2. Why is configuration management needed?
3. List ten characteristics of a bus which you would expect to feature in configuration management data.

11.10 Exercise Solutions

11.10.1 Self-Assessment Quiz 9.1 Solution

1. *What are “in-service assets”?*
 - a. In-service assets are those currently deployed for use within the organization.
2. *Name four activities involved in the support of in-service assets.*

Any of the following:

- Asset continuity planning and management
 - Maintenance
 - Facilities and resources planning
 - Asset Information Systems applications and developments
 - Regulatory issues awareness and response
 - Spares and consumables management
 - Technical developments monitoring and response
 - Configuration management
 - Change Management
 - Deeper maintenance planning
 - Outsourcing management
 - Replacement analysis
 - Disposal
 - Continuous Improvement
 - Planning and Budgeting for all of the above.
3. *What is the difference between a life cycle asset management plan and a planning period asset management plan?*
 - a. A Life Cycle Asset Management Plan is a plan formed by identifying the maintenance, repair and overhaul activities for the particular asset type over its whole or remaining life.

- b. A Planning-Period Asset Management Plan is a plan for the management of a whole portfolio of assets over a given time period, such as 1, 5, or 10 years. This is the type of plan that we need for developing budget proposals for the management of our in-service assets.
4. *What top-down factors can influence the management plan for in-service assets?*
- Market demand,
 - Product changes,
 - Technical changes,
 - Changes in the business structure or strategy,
 - Changes to the business plan.
5. *What bottom-up factors can influence the management plan for in-service assets?*
- Need to replace equipment
 - Need to upgrade equipment
 - Need to maintain, restore, or upgrade the service level
 - Technical or regulatory changes affecting operations or maintenance.
6. *Identify four reasons for having a planning-period (e.g., 5 year) asset management plan.*
- Informs senior management and other stakeholders of the current role and status of assets
 - Informs senior management and other stakeholders of the current role and status of the systems used to support the assets
 - Summarizes asset management plans for both assets and support services over the designated planning horizon
 - Links the current business plans and asset management plans
 - Links the asset plans to the CAPEX and OPEX budgets.

11.10.2 Configuration Management Solutions

1. *What is configuration management?*
- Configuration management involves keeping track of technical details of the assets in a fleet in regard to all the factors which are important for operation and maintenance.
2. *Why is configuration management needed?*
- If configuration management is lacking, an organization can find itself with an unknown mixture of equipment configurations, creating problems for operations, maintenance, and logistic support. Configuration management is important in relation to change management.

3. *List ten characteristics of a bus which you would expect to feature in configuration management data.*

Configuration data will include:

- Registration number
- Year of manufacture
- Make and model
- Engine type
- Engine serial number
- Fuel type
- Fuel capacity
- Kerb mass
- Length
- Width
- Height
- Wheelbase
- Turning circle
- Maintenance data document reference
- Engineering drawings reference
- Headlight type
- Transmission type
- Cruise control yes/no
- Number of seats
- Upholstery type
- Seat belts fitted yes/no
- Air conditioning yes/no
- Audio system
- Entertainment system
- Sunroof
- Navigation system
- Stop distance
- Tyre size and type.

11.11 Roll Over

Bruce pulled in beside Norm on the beach at Cable Bay. He jumped down and got a Darwin stubbie from the Esky.

“You got a new ute?” he asked.

“No, I cleaned it,” said Norm.

“What about the roll-bar, that’s new. Who put it on?”

“That little fabrication shop near the old pearl luggers. We all have them now. We’ve got a contract to do Non-Destructive Testing on the gas pipelines. Our boss

rolled his ute on a trip to Uranus Island and was lucky only to break his arm, so now it's become a safety thing. Weren't you supposed to get roll-bars ages ago?"

"Too right. It was after we had a fatal down by the dinosaur footprints. They sent out an engineer, Tom Peirce—I knew him from uni—and he drew up plans for roll-bars. But nothing happened. I saw him again later and he said that the engineering branch had said that they couldn't approve it because there wasn't an official standard to check it against."

"Sounds like a cop-out. They don't want to sign off and then get blamed if it's not perfect."

"Anyway, Tom said the operations people pushed them on it and they decided to do some tests. Apparently his design only covered 90 % of situations."

"90 % would be better than 0 %."

"There was another problem. We bought these utes over a few years and some were imported, some locally assembled from kits and some modified since in various ways. So the configurations are all over the shop, and apart from the original purchase records there is no documentation."

"So they would have to look at every vehicle separately. Not short of money are they?"

"Short of money! Not Canberra. No, there were actually going to do it, but someone pointed out that these utes were past their replacement age anyway so it wasn't worth doing."

"But you're still driving them!"

"Yes, but there is a big fleet replacement project in the works. Could come through any time—but I'm not holding my breath."

"Let's hope that you hold on to your head."

"Hey, look at that chick on the last camel."

"Wow!"

Chapter 12

Capital Planning and Budget

If you will the end you must will the means.
(A parliamentary saying).

Abstract To introduce the concepts of capital and operating budgets. To describe the process for developing a capital budget. To introduce the concept of capital rationing. To consider capital budget prioritization, based on returns, risks, and criticality of assets. *Outcomes* After reading this chapter you will know:

- The difference between capital and operating budgets;
- The typical structure of capital budgets;
- The process for developing capital requirements for particular equipment types and consolidating them across types;
- The meaning of capital rationing and how it affects budgets;
- Methods of dealing with capital rationing including prioritization based on financial return, equipment criticality, equipment age, and condition and risk;
- How to summarize the capital budget and to be aware of factors involved in managing the capital project portfolio.

12.1 Capital Planning Considerations

The allocation of resources within a company involves top management judgment, taking many factors into account. The financial viability of the organization is the leading concern, and in this respect, resources should be directed to those areas which have the best prospects for producing value. Value can arise in several forms, the most common being a financial return on investment. Value may be sought by generating new business, or by increasing production leading to greater sales volume, and in turn to greater sales value. Or the return may arise by reducing costs or alleviating bottlenecks.

At the same time as financial returns are being sought, it is important to take into account of other factors which are more defensive in nature. These include the

sustainment of existing assets and existing business, meeting legal, environmental, safety, or regulatory requirements, and the reduction of risk.

12.1.1 Cyclic Aspect

The condition and performance of a company's assets can often be allowed to deteriorate while still providing adequate service. Eventually in the life cycle of assets, the condition may reach a critical threshold where performance is difficult to sustain without significant expenditure. Understanding where you are in the cycle, and being able to evidence it, is critical to sound asset management, and to preparing financial and regulatory submissions
P.C. Fordham, South West Water Limited (UK). ERA Report 99-0764 1999.

12.2 What is a Budget?

A budget is an allocation of financial resources to a specific function or area, and represents a commitment on the part of management to the corresponding activity. Conversely, lack of a budget allocation to an activity is a de facto indication of lack of management commitment to that activity.

Budgets are generally based on reasoned proposals, and they help to promote good planning and a considered allocation of resources. Changes to budgets require senior management approval and require significant justification. Budgets help managers at all levels to plan and control business activity.

12.3 Types of Budget

In asset management there are two types of budget:

- a. Capital Budget, known as CAPEX = Capital Expenditure
- b. Operating and Maintenance Budget, known as OPEX = Operating Expenditure

The capital budget is used to purchase fixed assets and the operating budget is used to operate the business and to purchase expense items. The difference between the two is dictated partly by taxation systems which allow operating expenditure to be deducted from income in the current year in determining taxable income, whereas, only the depreciation of fixed assets is allowed as a current year tax deduction. Also, the two types of budget require quite different management. The operating budget is used by operating departments to cover outlays required to support their immediate activities, such as wages, materials, rents, and equipment lease payments. The capital budget is used to acquire major items of plant and equipment, requiring analysis of the business needs and investment options, followed by detailed acquisition planning and implementation.

The separation of budgets into CAPEX and OPEX can have some undesirable consequences. For example, there may be excessive OPEX expenditure in order to maintain aging equipment which should have been replaced earlier from the CAPEX budget.

The term TOTEX or Total Budget Expenditure refers to the total of CAPEX and OPEX. The TOTEX concept has value in drawing attention to the need to consider the interactions between the budgets, and ultimately, the total cost involved in supporting the asset functions. However, the interaction between CAPEX and OPEX is quite complex.

12.4 Budget Structure

Figure 12.1 shows a typical budgetary structure for a large corporation.

12.5 Devolution of Authority

An issue in the organization of a corporation is the extent to which authority should be delegated or devolved down to subsidiary levels. As an example, in a state-wide water supply system, initially there were 10 regions. Each region “owned” its local assets, and managed them—some well, some not so well. Because each region was small, their buying power, their access to capital funds, and their degree of technical support were limited.

To overcome these problems, ownership and decision making were centralized. This addressed the perceived problems, but had the disadvantage that local managers felt less interest in and less authority over, the assets in their region. In many cases the assets deteriorated.

“Not my problem,” the local managers said, as they disowned the remote centralized bureaucracy.

Fig. 12.1 Budget planning levels and time horizons

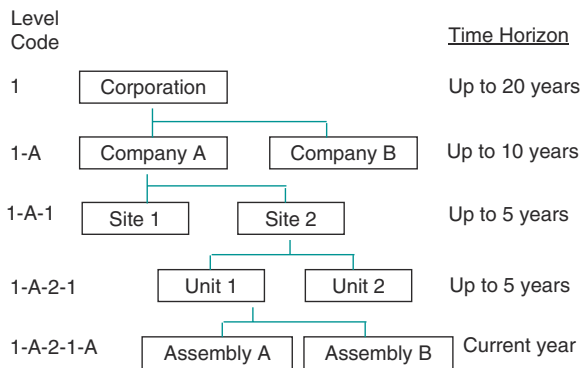

To strike a balance, the asset ownership was devolved back to four large regions, with positive effects. Technical and financial support functions remained centralized. The benefits and disbenefits of centralization are debatable, but it is important to keep users involved. The saying is: “big enough to cope, small enough to care”.

An example of a budgetary financial delegation policy is shown in Table 4.1 Financial Delegation Example.

12.6 Organizational Planning Process

Capital asset planning and budgeting involve identifying the most beneficial use of funds, planning, and scheduling the application of funds and arranging for the availability of those funds. Capital planning and budgeting are integral to the business development plan. The plan may involve consolidation, risk reduction, or outsourcing and is not necessarily expansionist.

The business development plan leads into a *capital expenditure program*. This will be consolidated across a number of different capability requirement areas. To check the financial viability of the whole program the organization will create analyses showing:

- i. Budgeted cash flow
- ii. Budgeted balance sheets
- iii. Budgeted profit and loss accounts.

The detailed development of these analyses will be an accounting or financial planning function rather than an asset management function, so we shall not consider them in detail. However, it is important that the data provided as a basis for these reports is as accurate as possible and this will require asset management input. The results may lead us to question the choice of earlier options, and may require modification for risk.

12.7 Asset Planning Process¹

In earlier chapters we have seen how the asset planning process involves several areas of development. The life cycle of specific assets is taken into account in determining Life Cycle Asset Management Plans. The continuity of asset provision is taken into account in Asset Continuity Planning. The requirement to match the needs of the business is taken into account in all the plans, but specifically in Capability Requirements Planning. The need to provide for and respond to support

¹ ISO 55001 Clause 8.1 Operational planning and control: “The organization shall ...implement processes...to implement the...asset management plans...”.

Fig. 12.2 The planning and budgeting process

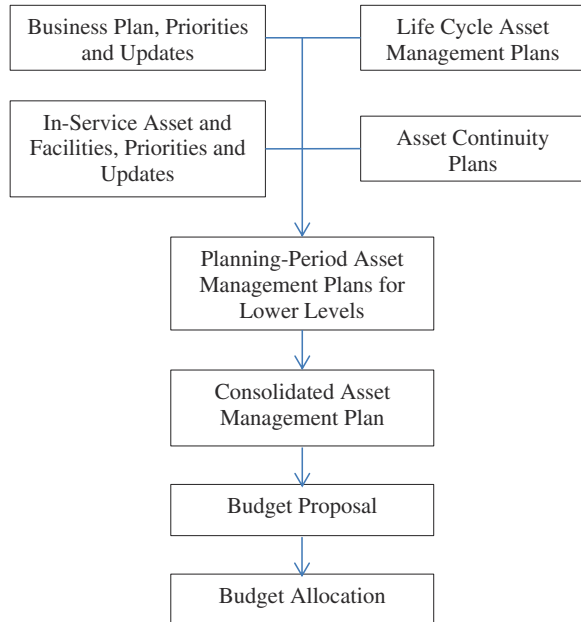

for the In-Service Assets are taken into account in the creation of Planning-Period Asset Management plans. The Planning-Period Asset Management Plans for lower levels of the organization are subsequently consolidated to produce Consolidated Asset Management Plans. These form the basis for budget proposals, leading ultimately to budget financial allocations. The process is summarized in Fig. 12.2.

12.7.1 Planning Periods

The capital expenditure program will consider a range of planning periods, such as 1, 3, 5, 10, and 20 year horizons. A rolling review will also apply, as circumstances develop. A balance must be struck between stability and flexibility in regard to changing situations. An appreciation of the lead times involved in implementing asset acquisition plans is essential, so we will need to firm up on our plans for particular projects for a given period ahead, dependent on the lead times involved.

12.7.2 Source and Application of Funds

It is not unusual for owners or senior management to have favored areas which do not correspond to those which are most profitable for the business. For example, a

railway may get the bulk of its net revenue from freight operations, but may direct the major part of its budget to passenger operations. Significant mismatches in the source and application of funds create a danger for any organization and should be guarded against. However, King Louis XIV is said to have appropriated one-third of the revenue of France to his personal use. He got away with it, but eventually his successors did not.

12.8 Capital Requirement Plans for Asset Types

Capital requirement plans for all asset types are developed, usually as part of an annual activity cycle. These are then consolidated into a master development and capital budget plan. The steps are summarized in Fig. 12.3. The consolidation across types is summarized in Fig. 12.4. Asset managers need to be fully aware of, and actively involved in the organization’s capital budget planning process. The bringing together of asset knowledge and business and financial knowledge into a sound decision making process is an essential part of the asset management contribution to the well-being of the organization.

Fig. 12.3 Capital planning and budgeting outline steps for an asset type

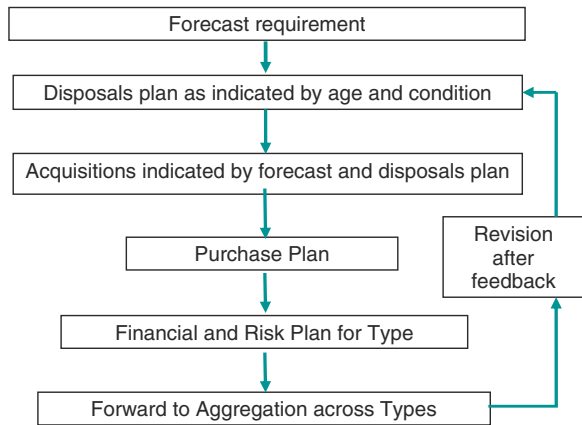
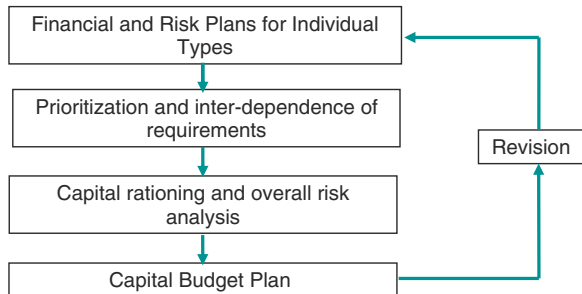

Fig. 12.4 Capital asset budget aggregation across types



12.9 Capital Budgeting Cycle

Within an organization, the capital budgeting process generally follows an annual cycle. There must also be provision for the response to emergency or unforeseen circumstances. A typical cycle can be as follows. This is based on a January–December annual cycle, but would vary to fit in with the relevant financial year timings.

1. February–March—Departmental level
 - a. Review life cycle asset management plans for major assets
 - b. Review current condition of assets
 - c. Determine status of current asset related projects
 - d. Review proposed acquisitions
 - e. Review proposed replacements
 - f. Review proposed overhauls
 - g. Review proposed disposals
 - h. Review proposed developments or opportunities
 - i. Review capital requirements for facilities.
2. April—Departmental level
 - a. Consolidate physical proposals in consultation with relevant managers
 - b. Prepare costings in consultation with finance personnel.
3. May–June—Business level
 - a. Consolidate physical proposals from departments and review priorities and costings. Prioritize list of proposals.
4. July–August—Business level
 - a. Capital budget proposals submitted for the following year.
5. September—Budget deliberations
6. October—Budget approved and issued for the following year.
7. November—Commence implementation of budget.

12.10 Capital Rationing

The requests on the capital budget often exceed the finance available. The prioritization of projects, and the making of decisions as to what items can be included in a given capital budget is known as capital rationing.

Some projects may be nondiscretionary in a regulatory sense—they have to be done. This typically includes, risk mitigation for health and safety, environmental protection, or reliability improvement in critical areas. Other projects may be essential to the business, such as maintaining the continuity of assets which provide essential services. Other projects may be discretionary, but nevertheless

important to the future success of the business. A major factor in capital budgeting is the financial return on capital invested.

The age and technical profile of major capital equipment will be determined by the pattern of installations in the past. We need to ensure that sufficient capital is allocated to meet the requirements for replacement and technical advance. Lumpy replacement patterns give rise to uneven capital requirements. Other things being equal, smoother capital demands through time are easier to manage. However, if major capital expenditure is justified it should be accepted and managed.

12.10.1 Capital Rationing Example—Postal Vans

A simple type of capital rationing decision occurs when a fleet of relatively small items requires on-going renewal.

Example Newistan Postal Service has a large fleet of vans, but a limited budget for van replacement. The replacement policy is to budget a selected amount each year to replace a number of oldest and highest mileage vans. Some contingency capital is also set aside for *spend-limit* replacements, that is where an expensive repair is required which is not justified in terms of the estimated remaining life of the vehicle, even though that vehicle would not normally be replaced on grounds of age alone.

The vans are identified by registration number. A list of vans is made by age in years and, within years, by kilometers run. Vans are then replaced down the list as far as the capital budget will allow.

Figure 12.5 shows an example in which vans at the oldest ages in the fleet have been listed in descending order by age, and within age groups, in descending order by kilometers run. A budget of \$200,000 has been allocated for replacements and the vans cost \$45,000 each. The budget allows the vans shown in the shaded area to be replaced. In practice some flexibility in application may allow engineering judgement of van condition to influence the precise outcome.

Registration number	Age (years)	Kilometers	Cumulative cost, \$	Policy
ABC123	12	246,897	45,000	Replace
ABD234	12	242,442	90,000	Replace
BWE876	11	189,342	135,000	Replace
BES541	11	163,903	180,000	Replace
BDF012	11	138,901	225,000	Keep
BBX945	11	99890	270,000	Keep

Fig. 12.5 Capital rationing—van replacement

12.10.2 Replacement Prioritization

In the vehicle fleet example just given, it is easy to rank the vehicles in priority order for replacement, since they are all basically the same. In other cases, we need to create a ranking system, based on factors such as condition and criticality. In order to establish a consistent terminology we can define descriptors for condition and for criticality as shown in Fig. 12.6.

The budget proposal then shows the condition and criticality of various proposed replacements. Figure 12.7 shows an example, with the replacement decision shown in the right-hand column. We see that replacement was approved for items 1–4 but not for items 5 and 6.

12.10.3 Condition/Criticality Plot

An example of a type of graphical display which can illustrate the status of many items on one page is shown in Fig. 12.8. This type of plot gives a compact view of the overall status of an organization’s assets to senior management.

Very high
High
Medium
Low
Very Low
Zero

Fig. 12.6 Classification descriptors for condition and criticality

Rank	Asset	Condition	Criticality	Replacement Cost	Decision
1	Excavator A	Zero	High	\$845,000	Replace
2	Pump 12	Very Low	High	\$290,000	Replace
3	Air Motor B	Very Low	Medium	\$135,000	Replace
4	Pump 56	Low	High	\$225,000	Replace
5	Conveyor 3	Low	Medium	\$380,000	Keep
6	Generator 1	Medium	Low	\$270,000	Keep

Fig. 12.7 Replacement prioritization by condition and criticality

Fig. 12.8 Condition/criticality plot

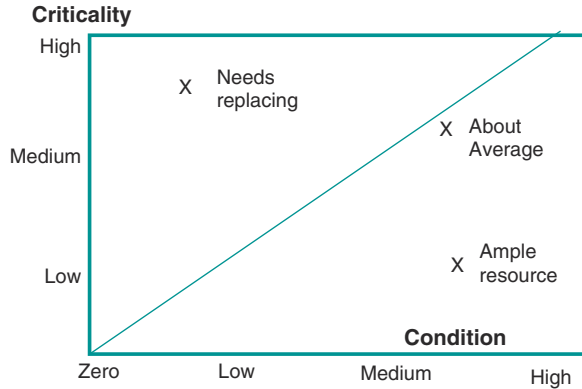

12.10.4 Financial Return

For new projects the financial returns are usually measured by the Internal Rate of Return (IRR). The definition and calculation of this measure are considered in another chapter.

12.10.5 Risk

Another factor that needs to be taken into account is the risks involved if a project is or is not undertaken. This may be concerned with safety, regulatory requirements, or a risk of business loss or lost opportunity.

From the point of view of the asset manager, it is advisable to make clear to senior management the risks involved both in carrying out a project and also in failing to approve a project. It is then up to senior management to make a final decision. The advantage of the risk-based approach is that it can create a situation of positive dialog between asset managers and senior management as the merits and risks of various projects are discussed. A reasonably argued case should be presented for each project, without crying wolf or being smart after the event.

Figure 12.9 shows an example where a number of projects have been presented to a budget committee. The list includes projects which have been included for environmental or safety reasons, and ones which are profit motivated and show their internal rate of return (IRR). The right-hand column shows the ranking of the projects by the committee. The rank 1 project is seen as essential from an environmental and regulatory point of view. The rank 2 project has a high-internal rate of return and is seen as essential to the on-going needs of the business. The rank 3 project is a safety requirement, and so on.

Project	Cost \$M	IRR	Risk description	Risk rank	Project Rank
Extend tailings dam	1.6	-	Environmental	1	1
Second unloading station	3.6	36%	Production opportunity cost	-	2
Replace ventilation compressor No. 3	1.3	-	Safety risk if fails	2	3
Replace dewatering pumps on level 19	2.8	-	Production loss if failures	3	4
Acquire 2 loaders	1.55	22%	Production opportunity cost	-	5

Fig. 12.9 Project rankings with returns and risk

12.11 The Capital Budget

Ultimately, senior management brings together the various decisions into a consolidated capital budget. An example is shown in Fig. 12.10.

12.12 Managing the Capital Project Portfolio

The direction, monitoring, and control of the capital project portfolio is a major commitment of senior management. The summary in Fig. 12.10 shows a portfolio of capital projects which are at various stages of development. The status column shows the stage of progress for each project. The projects at the top of the list are those that are currently in progress of acquisition or development, projects 1–3. Project 4 is approved but not yet started. Projects 5 and 6 are in the feasibility planning stage, project 7 is in the pre feasibility planning stage, and projects 8 and 9 are at the requirements analysis stage. Projects will progress up the list as their status develops toward completion. In practice, the number of projects may be larger and separate tables may be made to focus on projects at particular stages of development or on projects for particular areas of the business.

Each project has a project manager who reports on the project to a senior manager in the area to which the project relates. Senior management will coordinate progress and financial requirements. The availability of finance can depend on many factors and is not necessarily smooth through time. Both the requirements of the projects and the financial situation of the organization can vary depending upon external and internal factors. It is common to find that projects slip back in time, although this should be avoided wherever possible. Delay factors include changes in scope (naughty), delays in specifying requirements, and delays in supply. In organizations with strict annual budgeting systems, delays in one project may work to the advantage of another.

Capital Budget Summary		Years ahead					
Project	Status	1	2	3	4	5	6
1. Vehicles type A	Implementation in progress	200	150	100	250	250	150
2. Building C development	Implementation In progress	250	4000	1500	0	0	0
3. Site X clear and dispose	Implementation In progress	500	-3000	0	0	0	0
4. Building B extension	Plan approved	0	1500	1500	0	0	0
5. Pumping system replace	Feasibility stage	0	2000	0	0	0	0
6. Vehicles type B	Feasibility stage	0	0	550	675	300	750
7. Building A refurbishment	Pre-feasibility stage	0	0	0	2000	0	0
8. Production stream A upgrade	Requirements /Analysis	0	0	0	0	3500	0
9. Power transformer replace	Requirements /Concept	0	0	0	0	5000	0
Total cost \$k		950	4650	3650	2925	9050	900

Fig. 12.10 Capital planning budget summary, \$k

Care must be taken to identify cases where projects are interrelated, since progress in one may then influence the development of another.

12.12.1 Capital Budget for Current Year

In the shorter term, we also need to manage the capital budget for the current year, and for other medium-term horizons. Figure 12.11 shows an example of a current year capital budget, showing for a number of items, expenditure year to date (YTD) and planned expenditure for the rest of the year (ROY). Uncommitted funds are also shown. The management of the budget will involve working with the managers responsible for the various task items or projects. An understanding

	A	B	C	D	E	F	G
1	Item	Budget for year	Actual YTD	Planned ROY	Actual+Planned	Uncommitted	Date
2	Road Section A	\$3,692,450	\$745,990	\$540,221	\$1,286,211	\$2,406,239	4-Oct
3	Road Section B	\$1,458,321	\$580,432	\$993,450	\$1,573,882	(\$115,561)	
4	Storm Water Area K	\$2,576,449	\$903,034	\$840,453	\$1,743,487	\$832,962	
5	New Recreation Bldg	\$760,652	\$188,930	\$650,000	\$838,930	(\$78,278)	
6	Parkland Development	\$275,500	\$98,405	\$48,775	\$147,180	\$128,320	
7	Totals	\$8,763,372	\$2,516,791	\$3,072,899	\$5,589,690	\$3,173,682	

Fig. 12.11 Current year capital budget

of the lead time factors in projects, the need to manage resources within and between projects, and awareness of the risks involved, will assist the budget manager to work toward the best achievable outcome.

12.13 Contingency Allowances

Emergency, urgent, or critical work can arise which the original asset management plan and budget have not allowed for. A contingency budget should be held to cover such situations. It is important that asset managers respond adequately to actual or potential failures and to situations involving risks to safety or the environment. Financial support should be sought as the situation justifies.

12.14 Exercises

12.14.1 Self-Assessment Exercise 12.1

1. What is a budget?
2. What do the abbreviations CAPEX and OPEX stand for?
3. What is capital rationing?
4. How would you monitor budgetary expenditure?

12.14.2 Long River Ferry Company Exercise

The Long River Ferry Company currently operates a fleet of small wooden ferry boats. They are planning to introduce three new, larger boats which are faster and have air-conditioning. The larger boats will require new pontoons and there is also a requirement that work to protect the riverbank from erosion be undertaken before large boats are introduced. It is believed that the larger boats will increase revenue, but some of the customers for the larger boats will be displaced from the

Fig. 12.12 Small boats cost data

Year	1	2	3	4
Boats req. overhaul @\$0.5M per boat	4	4	2	2
Overhaul cost \$M	2	2	1	1
Boats req. replace	6	3	0	5
Replacement cost \$M @ \$2M per boat	12	6	0	10

Fig. 12.13 Large boats cost data

Year	1	2	3	4
Acquisition Boat#1, \$M	3	5	0	0
Acquisition Boat#2, \$M	0	3	5	0
Acquisition Boat#3, \$M	0	0	3	5

smaller ones. If Long River does not introduce larger boats there is a distinct possibility that a rival company will introduce similar boats and capture the higher priced end of the market.

Long River has three divisional managers who respectively are responsible for:

1. Small boats,
2. Large boat project, and
3. Shore facilities.

The divisional managers have produced the following budget information:

Shore Facilities

Pontoons \$2 M required in year prior to commencement of large boat#1, and \$1 M in year prior to commencement of large boat#3.

Riverbank \$4 M required in year prior to commencement of large boat#1 (Figs. 12.12 and 12.13).

Large boats require a payment of \$3 M in the year prior to acquisition and \$5 M in the year of acquisition.

Task Prepare a capital budget for Long River for the four-year period. Indicate options which may benefit the business in overall financial and operational terms.

12.15 Are Your Assets Liabilities?

Shortly after Jock joined the asset management group his boss Dan called him in. “We are going to do a due diligence on Front-IT,” said Dan.

Jock was not sure what a due diligence was so he kept quiet. All he knew was that Albany—the large conglomerate where he and Dan worked—were putting together a bid for Front-IT.

“What is the main idea?” asked Jock.

“We need to check out their assets,” said Dan. “They have nice offices in a smart location, lots of modern computer gear and the managers all have swishy company cars so it looks pretty good as far as I can see.”

Check it out they did. The cars and the computer equipment were all leased. The office building was 6 months into a 3-year lease—making it a cost commitment. The only fixed asset on the books was a backroom computer system valued at \$5,000,000—but when they got specialists to look at it, it turned out to be obsolete and to have zero market or practical value.

Dan and Jock made their report. Later at a drinks session to celebrate the acquisition, Sean, a lead guy on the takeover team spoke to Dan and Jock.

“You did a good job on the asset evaluation,” he said.

“But they weren’t worth anything,” said Jock.

“Too right,” said Sean, “It brought the price down a treat.”

“But why did we go ahead,” said Jock, puzzled.

“They had some heavily amortized intangibles we were interested in,” said Sean, turning away as though he had said too much.

Jock did not know what an intangible was, much less a heavily amortized one. Front-IT looked like a dead duck from where he saw it.

At home that night it occurred to Jock that Sheila might know about intangible assets.

“Can I ask you a question?” said Jock.

“Yes,” said Sheila, brightly.

“It’s not that kind of question,” said Jock, “It’s about intangible assets and amortization.”

“Oh,” said Sheila, and she explained that an intangible asset was something like a patent, or intellectual property or goodwill. It had value but was not money and was not a physical thing. The value declined over time, and the decrease was called amortization.

“It’s like depreciation,” she said.

At work later Jock asked Dan if he knew why Albany had bought Front-IT.

“Apparently Front-IT developed an advanced safety relay for electricity transmission systems years ago,” said Dan.

“They still own the patent. It seems that our guys reckon they can develop the idea further and that we can use it on our upcoming projects and also license it out.”

“I see,” said Jock.

12.16 Exercise Solutions

12.16.1 Self-Assessment Exercise 12.1 Solution

1. *What is a budget?*

A budget is an allocation of financial resources to a specific function or area.

2. *What do the abbreviations CAPEX and OPEX stand for?*

CAPEX is Capital Expenditure and OPEX is Operating Expenditure.

3. *What is capital rationing?*

Capital rationing is the determination of which items can be included within a limited allowable expenditure of a given budget.

4. *How would you monitor budgetary expenditure?*

- a. Create a budget in a spreadsheet (or other established system) indicating the various cost categories and the amounts allocated.
- b. Record actual expenditure as it occurs.
- c. Calculate planned expenditure for rest of the planning period. This is based on the original budget, adjusted to allow for known or expected changes. These may be increased or reduced relative to the original plan.
- d. Calculate the balance of commitments. This will be a positive amount if there is a projected budget surplus and a negative amount if there is a projected budget shortfall.
- e. Take steps to remain within budget, or discuss the situation with management if an unavoidable shortfall or surplus is emerging.

12.16.2 Long River Ferry Company Exercise Solution

The capital expenditure as proposed is as follows:

Year	1	2	3	4
Small boats	14	8	1	11
Large boats	3	8	8	5
Shore facilities	6	0	1	0
Total	23	16	10	16

Suggestions Propose cutting back expenditure on small boats in years 1 and 2 in case demand is taken by large boats from year 3. Better demand information may emerge over years 1 and 2. Market may switch to large boats, or may grow in total.

Is it possible to lease boats to cover the short term?

Chapter 13

Asset Management Information Systems

Abstract The aim of this chapter is to outline the functions of an asset management information system and to consider issues relating to the use, resourcing, and operation of the system. *Outcomes* After reading this chapter you will know the main applications for which an asset management information system is programmed and the type of coding systems which are used to identify equipment, locations, and activities. You will be aware of the need for adequate resources to maintain the system and for user training in its use. You will see the structure of the data flows and be aware of the role of the system in the on-going management of current tasks.

13.1 Information System Role and Applications¹

An asset management information system is a computer-based system which is designed to assist the user to create and maintain documentation for the asset management function.

Asset management requires accurate, comprehensive, documented details of the identity, operating, and maintenance parameters of equipment. This information is utilized throughout the life cycle of the equipment by plant operating and maintenance personnel.

Historical information aids in troubleshooting, root cause analysis, and the identification of safety performance and improvement opportunities by providing data for analysis and decision making. The records also provide evidence to regulatory bodies that maintenance tasks are being performed so that the technical integrity of the equipment is maintained.

¹ ISO 55001 Clause 7.5 Information requirements “The organization shall determine its information requirements...” “The organization shall... implement... processes for managing its information” and Clause 7.6 Documented information “The organization’s asset management system shall include...documented information...”.

Early computer systems were developed for individual management areas, such as maintenance, accounting, or personnel. Systems originally developed specifically for maintenance are known as Computerized Maintenance Management Systems or CMMS. Later, more integrated systems were developed, which may be described as “enterprise asset management systems”. For asset management purposes it is desirable to have an integrated system which covers the following applications:

- Asset Register including listing of maintainable assets with full range of configuration management parameters, cost and depreciation information, valuation, and condition information
- Estimating and costing
- Budgeting and budgetary reports
- Links to accounting systems
- Routine maintenance lists
- Routine maintenance prompts
- Work requests
- Planning and scheduling
- Work order management
- Spare parts and consumables inventory management
- Suppliers and purchasing
- Data logging and remote data entry and reporting

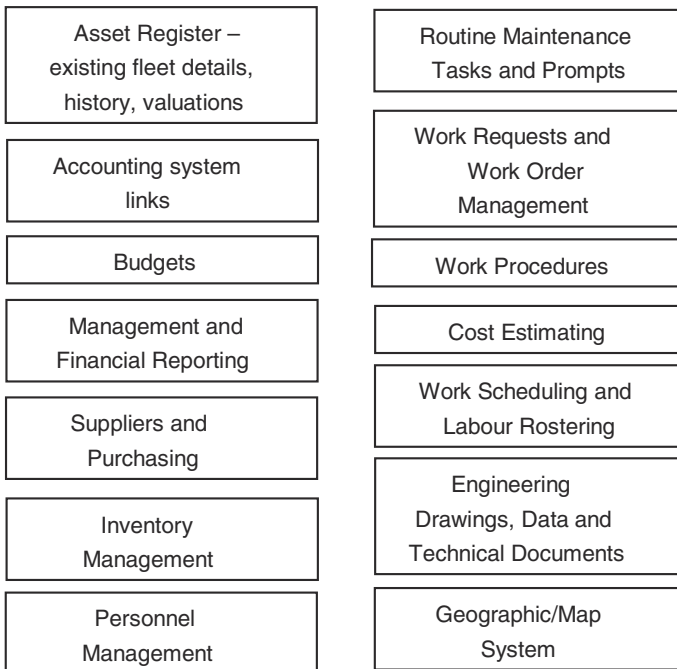

Fig. 13.1 Asset management information system

- Work history including costs and renewals
- Reliability and cost reports
- Global positioning systems, mapping, and GIS
- Work procedures including safety
- Tools and equipment inventory
- Labor data, personnel, availability, rosters, assignment
- Management reports.

These systems require extensive initial data setup, on-going data input, working methods which are consistently applied, training, and implementation support. The range of applications is shown in graphical form in Fig. 13.1.

13.2 Base Data and the Need for Coding

When a company buys an asset management software system it buys an *empty* database. To use the system, it must populate the database with data from its own business. This requires the company to establish a system for designating and coding all the entities involved in the various applications that it requires. Systematic structuring and coding is essential. The codings required for financial purposes and for maintenance purposes involve different levels of detail, and it is therefore usually necessary to have both Account Codes and Functional Location Codes within the system.

13.2.1 Fixed Plant and Functional Locations

The data requirements differ to some extent between fixed and mobile equipment. We shall consider fixed plant first.

A functional location is a place where an item is located in order to carry out a given function. In fixed or static plant or buildings, a functional location corresponds to a place and the function of the item located there. For example, in a house, the kitchen is a different functional location to a bathroom. Further breakdown of locations would identify such functional locations as the kitchen sink, cooker, and refrigerator locations.

13.2.1.1 Why Do We Need Functional Locations?

The functional location enables us to identify locations for operational and maintenance purposes. The functional location is used on Work Requests, Work Orders, Inspection Plans, and related documents such as safety or emergency plans. Thus if a user has a refrigerator in a certain place which is faulty, they create a Work Request which specifies the Functional Location. The specific item at a functional location may change, but the functional location remains the same. Thus, if the

Fig. 13.2 Plant area location coding (part)

Area	Location or Grouping
100	Administration
110	Administration General
111	Management and Supervision
130	Supply
131	Storage
132	Fuel
150	Accommodation
154	Site Camp
160	Site Maintenance
162	Buildings
170	Services
171	Power
172	Water Supply
173	Potable Water
200	Mining
220	Dewatering
221	Groundwater
222	In Pit Water
290	Environment
300	Concentrator
310	Concentrator General
312	Buildings
313	Spares
316	Smelting
318	Cobalt Study

refrigerator at a given functional location changes, the functional location remains the same. If we wish to track the history of a particular refrigerator, we need to record information which specifies the serial number.

As a further example, consider a mining site. The site has different areas and different activities within those areas. Figure 13.2 shows part of the higher level functional location coding system for the site. Some judgment is required in order to achieve clarity but to avoid an excess of detail. The level of detail required for accounting purposes is generally less than that required for maintenance purposes.

Figure 13.3 shows entries for specific assets within an area. The style of the detailed entries will reflect the industrial application. For example, in process plant the identification may be by drawing reference and tag number.

13.2.1.2 Global Positioning Systems (GPS) and Mapping

For geographically dispersed assets, the GPS location is a useful feature to show in the asset register. Maps and photographs are also valuable aids to identifying assets and assessing condition.

Plant Ref	Description	Account Code
110RD501	TAIT T3020 II Hand Held Radio Manager	H610
110RD502	TAIT T3020 II Hand Held Radio Admin	H610
110RD503	TAIT T3020 II Hand Held Radio IS Admin	H610
110RD508	TAIT T3020 II Hand Held Radio Health &S	H610
130AC001	Air Conditioner Purchasing	H630
130AC002	Air Conditioner Purchasing	H630
130AC003	Air Conditioner Supers Office	H630
130AC004	Air Conditioner Supers Office	H630
130AC005	Air Conditioner Despatch	H630
130AC006	Air Conditioner Despatch	H630
130AP	Area 130 Supply Electrical Appliances	H630
130AP001	Cordless Jug Warehouse	H630
130AP002	Microwave Oven Warehouse	H630
130AP003	Refrigerator Warehouse	H630
130AP004	Ext Lead Short Warehouse Office	H630
130AP005	Ext Lead 8 Mtr Warehouse Office	H630
130AP006	Portable Outlet 4 Pole Warehouse Office	H630
130AP007	Mobile Phone Charger Warehouse Office	H630
130AP008	Portable Outlet 4 Pole Warehouse Office	H630

Fig. 13.3 Asset register items within area location

13.2.2 Location Code Structure

The following example relates to an electricity transmission system. The system covers a number of geographic areas, labeled A, B, C, etc. Within each area there are a number of substations. In area A the substations are labeled A01, A02, and so on. The identifier substrings are kept to uniform length to facilitate report generation.

Within each substation there are a number of circuit breaker bays. In substation A01 there are bays A01-01, A01-02, and so on. Then within a particular bay there are individual circuit breakers, and for any circuit breaker there are important components which include Current Transformers and Voltage Transformers (these are instrument transformers which are part of the circuit protection system). The coding system is illustrated in Fig. 13.4.

The system enables us to identify any item down to the coded level of components. Also, in analyzing historical data, for example, all work orders relating to Current Transformers can be extracted by selecting on code “CT” in positions 8:9.

Fig. 13.4 Functional location coding—electricity substation

Area A
Substation A01-00-000
Bay A01-01-000
Circuit breaker A01-01-CB1
Current transformer A01-01-CT1
Voltage transformer A01-01-VT1
Circuit breaker A01-01-CB2
Current transformer A01-01-CT2
Voltage transformer A01-01-VT2
Bay A01-02-000
Circuit breaker A01-02-CB1

13.2.3 Mobile Plant Coding

For mobile plant, such as motor vehicles, railway wagons, or aircraft, the vehicles themselves will be identified by serial number. Functional locations will be defined for the constituent internal locations. These location codes will apply to all similar types of plant. Major assemblies for which individual tracking is required will also be identified by serial number. Serial number tracking is necessary for major assemblies which may move between functional locations, if their life history is to be traceable.

An item type, such as a particular model of diesel engine, will be identified by:

- Type Code
- Description
- Manufacturer
- Technical characteristics
- Power rating
- Number of cylinders and layout
- Size and weight ...
- Bill of Materials/Spares catalog reference.

A specific item, such as a particular diesel engine, will be identified by:

- Serial Number
- Type Code
- Date of Manufacture

An example of mobile plant functional location coding is shown in Fig. 13.5 for an electric train.

13.2.4 Activity and Trade Codes

Examples of activity type and trade type codes are shown in Fig. 13.6.

Fig. 13.5 Functional location coding for an electric train (part)

01 ELECTRICAL SYSTEM	
0101	AC Breaker Panel
0102	AC Auxiliary Control Panel
0103	Door Supply
0104	Battery Charger
0105	Battery System
0106	DC Breaker Panel
0107	DC Auxiliary Control Panel
0108	Grounding System
02 PNEUMATIC SYSTEM	
0201	Air Compressor
0202	Air Control Package
0203	Brake Control Package
0204	Auxiliary Release Package
03 AUTOMATIC TRAIN CONTROL SYSTEM	
0301	Automatic Train Protection
0302	Automatic Train Operation
0303	Automatic Train Supervision
04 PROPULSION AND DYNAMIC BRAKING SYSTEM	
0401	Propulsion System Devices
0402	Dynamic Braking System Devices
0403	Traction Motor
0404	Motor Control Box
0405	Brake Resistors
0406	Brake Transformer
0407	Brake Interposing Relay Box
0408	Propulsion Monitor Panel

13.3 Resourcing and Managing the System

13.3.1 Data Administration

Maintenance data administration must be a recognized activity. A combination of staff abilities is required, since technical knowledge is needed for part of the work, but data handling skills are a predominant requirement in other phases of the application. Adequate and consistent resources must be allocated to creating and maintaining the data otherwise it will quickly become worthless. This includes keeping up-to-date the register of maintainable assets, the maintenance policies, and supporting data such as work procedures and safety procedures.

13.3.2 Information Technology Support

Information technology support for the asset management information system is essential. Developments will be on-going in terms of both the application and the underlying information technology.

Fig. 13.6 Activity codes and trade codes

ACTIVITY CODES - EXAMPLE	
I	Inspect
R	Repair
X	Replace
A	Adjust
L	Lubrication, Fluids
C	Condition Monitoring
F	Fabrication, Manufacture
TRADE CODES - EXAMPLE	
M	Mechanical
E	Electrical
W	Welder
T	Textile
I	Instrument
A	Air Conditioning
L	Laborer

13.3.3 Users

All trades personnel should be familiar with the system. This familiarization must be part of the training requirement for all potential users. It is highly desirable to get those who enter data, typically the trades persons who carry out work, to make use of some reporting features of the system. This will provide motivation for maintaining the quality of the data input. The more extensively the system is used, the greater are the benefits.

13.4 Reports and Their Uses

The following are examples of the type of reports which can generally be generated from the asset management computer system, and some of the uses to which these reports are put.

- Asset identification, location, and valuation.
- Budget expenditure year to date by account code, by equipment type, by location. This report helps with current budgetary management, and with the assessment of future resources.

- Operational loss reports. Check causes and follow up to improve performance and reliability.
- Unscheduled work orders. Check causes and follow up to improve performance and reliability. Check history to see if job is recurring, if so investigate, improve—Pareto analysis. Review downtime and seek reductions using rotables, repair kits, better diagnostics, training, spares, and support equipment availability. Update job procedures and job requirements. Review inspection and replacement intervals.
- Manpower utilization by trade; by equipment type; by location. This report helps with the allocation of staff by location, and with determining staff requirements.
- Maintenance cost by item type by year of life. This report provides a basis for replacement planning.
- Spares utilization by part number. This report provides the basic input into stock control parameter setting and reorder decisions. Use forecasting and reorder analysis to review spare parts holdings.
- Failure frequency by failure mode and year of life. This report provides a basis for determining optimal component replacement and inspection policies.
- Assembly replacement events and odometer readings. This provides a basis for planning and monitoring policy regarding rotables provision and repair services.

13.5 Document Control²

A system for document control must be established in order to ensure that documents are adequately protected for improper use, loss of integrity, and loss of confidentiality.

13.6 Implementing Changes

A factor in the management of computer systems is the need to make changes, but at the same time to exercise control over the validity of changes. Anyone who has tried to notify their bank of their change of address will be aware of the problem. Figure 13.7 shows the steps involved in implementing a data change in a computer system. Data integrity can only be achieved at the expense of a considerable number of checks. A *data custodian* has responsibility for overseeing changes.

² ISO 55001 Clause 7.6.3 Control of documented information: “Documented information...shall be controlled...”.

Fig. 13.7 Steps in implementing data changes

Create Data Change Request	Anyone
Approve Request	Operations or maintenance supervisor
Identify full range of changes	Data coordinator
Agree changes	Data custodian
Implement changes	Data coordinator
Review and sign off change	Change requester

13.7 Exercises

13.7.1 Asset Data Setup Exercise

This exercise relates to a part of a Chlorination Blower. Chlorination Blowers are used in oil refineries as part of the catalytic reforming process. Initially, you are setting up the asset register. A small section of the Bill of Materials for the blower is shown in Figs. 13.8 and 13.9. Use this to:

- Create a coding system for the components shown.
- Create coding systems for the trade and activities shown.

Fig. 13.8 Chlorination blower bill of materials

Chlorination Blower Reformer A
Mechanical System
Housing
Casing
Fan Shaft
Seals
Guards
Coupling
Guard
Impeller
Bearings
Seals
<i>By part number:</i>
Plugs
Fasteners

Fig. 13.9 Trade and activity types

<p>Trade: Mechanical</p> <p>Activity Types:</p> <ul style="list-style-type: none"> Inspect Lubricate Replace Repair Adjust Condition Monitor (Vibration, Thermal, NDT) Fabricate/Manufacture

The following exercises indicate only the brief descriptions and related codes for the key tasks.

- An operator carrying out a shift inspection sees that the casing of the blower is loose and leaking fluid. Create a work request indicating the fault location by code and the fault description.
- A site check indicates that a casing bolt is broken. Create a work order to replace the bolt and to carry out vibration monitoring of the fan.
- Vibration monitoring indicates that an impeller bearing needs replacing. Create a work order for this job.

13.7.2 Pacific Earth Moving Part 4 AM Info. System

The senior management of Pacific Earth Moving is assessing the need to introduce a comprehensive asset management information system to replace a number of different software systems. Your group has been retained to advise on the desirability or otherwise of such a system and the support which such a system would require in order to implement and maintain it.

- (a) List in dot point form the functions which an asset management information system can be expected to support and indicate their value to the company.
- (b) List in dot point form the resources needed to implement and support an asset management information system.
- (c) Briefly summarize the case for and against such a system for presentation to a company board consisting predominantly of lawyers, financiers, and entrepreneurs.

13.8 Exercise Solutions

13.8.1 Asset Data Setup Exercise

Chlorination Blower Reformer A	RA-CB-00-00-00-00
Mechanical System	RA-CB-MS-00-00-00
Housing	RA-CB-MS-HS-00-00
Casing	RA-CB-MS-CA-00-00
Fan Shaft	RA-CB-MS-FS-00-00
Seals	RA-CB-MS-FS-SE-00
Guards	RA-CB-MS-FS-GD-00
Coupling	RA-CB-MS-CO-00-00
Guard	RA-CB-MS-CO-GD-00
Impeller	RA-CB-MS-IM-00-00
Bearings	RA-CB-MS-IM-BE-00
Seals	RA-CB-MS-IM-BE-SE

By part number:

Plugs

Fasteners

Numerous other 'nickel and dime' parts.

Trade: Mechanical	M
Activity Types:	
Inspect	I
Lubrication	L
Replace	X
Repair	R
Adjust	A
Vibration Monitor	V
Fabricate/Manufacture	F

Work Request. Loose casing and fluid leak. Location = RA-CB-MS-CA-00-00

Inspection Reference: INS1234

Work Order 1. Location = RA-CB-MS-CA-00-00

Replace broken casing bolt; Trade M, Activity X

Location = RA-CB-MS-00-00-00

Vibration monitor blower; Trade M, Activity V

Work Order 2. Location = RA-CB-MS-IM-BE-00

Replace impeller bearing; Trade M, Activity X

13.8.2 Pacific Earth Moving Part 4 AM Info. System Solution

- Functions are listed in Sect. 13.1.
- Resource support requirements are required for the computer system itself and the related hardware and software support, plus data administration and

training for all users. Trades personnel should be fully familiar with the system and make extensive use of it. See Sects. [13.3.1](#) and [13.3.2](#).

- c. An information system is essential to maintain a record of maintainable assets. This is a separate requirement from the financial asset viewpoint, although some systems may offer both features. Key functions include, work management, scheduling maintenance, records of equipment maintenance, inventory control and spares purchasing, maintenance budget planning and control, and work procedures including safety and permit systems. Refer to Sect. [19.1](#), Chap. [20](#), and Sect. [21.1.3](#).

Part IV
General Management Considerations

Chapter 14

Cost–Benefit Analysis

*A cynic is a person who knows the price of everything
and the value of nothing.*
Oscar Wilde

Abstract The aim of this chapter is to discuss situations where the benefits of some or all of the activities are not measurable in terms of direct financial returns. We then indicate how asset management decisions may be approached in these cases. *Outcomes* After reading this chapter you will be aware of those areas where benefits are wholly or partly of a nature which is not readily quantifiable in financial terms. You will learn about how to approach problems of this type and how to carry out cost–benefit analysis using a planning balance sheet.

14.1 Cost–Benefit Analysis¹

Cost–benefit analysis is the analysis of projects in which some of the inputs and outputs can be assigned financial values but some cannot. Cost–benefit analysis is a major factor in asset developments which have social or environmental impacts. The aim here is to present a basic outline of the concepts used in approaching cost–benefit analysis.

14.1.1 Nonfinancial Benefits

Examples of types of project where there are nonfinancial benefits occur extensively in the provision for community services in areas such as:

- Health,
- Safety,

¹ A.S. Goodman and M. Hastak, “Infrastructure Planning Handbook,” particularly Chaps. 11–13.

- Education,
- Recreational or sporting facilities,
- Parks and gardens, and
- General user infrastructure.

Other areas where no direct financial benefit is available but investment can still be necessary or worth while are:

- Value preserving or protecting activities, in that they reduce the probability of, or effects of, deterioration, failure, accidents, faults, fatigue, or delays.
- Meeting regulatory requirements. This is usually in relation to technical, health, safety, or environmental considerations and may include the identification of, and compliance with, technical regulations or standards.
- Exploratory or pre-feasibility studies which may or may not lead on to business generating projects, examples; geological evaluation of a prospective mineral area; evaluation of a condition monitoring technique to assess its applicability and effectiveness in a particular application.
- Improvements in materials handling, access, communication, housekeeping, simplifying operations, layout, or storage.
- Research with the aim of furthering knowledge, but without a specific, pre-defined financial motivation.

14.2 Cost–Benefit Analysis Outline

Cost–Benefit Analysis involves the evaluation of scenarios where the outcomes involve both financial and nonfinancial benefits and disbenefits. We wish to have an approach to striking a balance between the financially quantifiable and the more subjective aspects of an issue.

Examples occur particularly in areas involving the environment and in public works. An example is the Brisbane—Gold Coast freeway, the route of which was changed to protect the habitat of koala bears. Another case is the Mullum Mullum tunnel in Melbourne which was created to avoid disturbing a flora and fauna sensitive area. The cost of these route choices was significantly higher than the minimum cost alternative, but was considered acceptable by the general community. With electricity transmission lines there is often public resistance to the creation of new routes, and it is easier to upgrade an existing route than to create a new one. However, almost every project gives rise to protests, but a simple BANANA (Build Absolutely Nothing Anywhere Near Anything) approach is not the complete answer.

14.2.1 A Basic Example

The problem addressed by cost–benefit analysis can be characterized by the following scenario based on options for a road building project. The cost–benefit analysis here is looked at from a general community perspective. The financial

analysis of the project as an investment for a toll road would focus financially on construction cost versus toll income, but may include a contribution from government in recognition of amenity value. The following options, costs benefits and disbenefits exist for the project.

1. Do not build the road. This is the base case against which the other options are compared.

Cost Zero

Benefit Zero

Disbenefits Traffic congestion and environmental impact on existing roads.

2. Build a tunnel.

Cost \$2,000,000,000. Toll of \$5 per vehicle.

Benefits Reduced traffic congestion and reduced environmental impact on existing roads. Reduced travel times for vehicles, leading to greater general efficiency of movement and trade.

Disbenefits Cost to road users.

3. Build road through parkland.

Cost \$1,000,000,000. Toll of \$2.50 per vehicle.

Benefits Reduced traffic congestion and reduced environmental impact on existing roads. Reduced travel times for vehicles, leading to greater general efficiency of movement and trade.

Disbenefits Reduced area of parkland for community. Impact on wildlife habitat. Cost to road users, but less than for tunnel.

4. Route the road through an existing developed area by compulsory purchase of land and properties.

Costs Road building \$500,000,000. Compensation to existing property owners \$200,000,000. No toll.

Benefits Reduced travel times for vehicles, leading to greater general efficiency of movement and trade. Property owners who are compensated can redeploy their part of the cost and this is therefore a financial transfer rather than a sunk cost.

Disbenefits Impact on developed areas close to route. Traffic congestion still significant.

The point of cost–benefit analysis is that there is no purely financial solution, and that a judgment must be made between options that involve some well-defined costs, some less well-defined costs, revenues or transfers, and some subjective benefits and disbenefits.

14.3 Needs and Wants

In cost–benefit analysis it is desirable to recognize a spectrum of desirability which ranges from needs to wants. Thus, a community *needs* an adequate and healthy water supply, but may also *want* to preserve swamp land for frogs. This is also an issue of priorities. At a basic level, many people would see that the humans

Question	Comment
Can all or some of the function be User Pays?	
Is expenditure by the taxpayers or a similar broad non-benefitting group justified?	
Can the function be provided within an existing service?	
Can the function replace or reduce an existing one?	
Does the proposal provide an opportunity to rationalize related activities?	
Are all the features requested really required?	
Are the requested capacity and availability fully justified?	
Can the function be outsourced?	
Can economies be made in regard to development effort, materials, finishes, energy consumption, maintenance?	

Fig. 14.1 Value analysis questionnaire for cost–benefit project

are more important than the frogs, but once human needs are met then preserving the frogs is a worthwhile benefit. Ideally, a balance of expectations must be struck.

We should aim to increase the combined economic and social benefits to the community as a whole. It helps if we enable members of the community to participate in selection and prioritization of projects, but it is likely that some people will oppose any given outcome. Public education regarding the various options will help to achieve a solution which reflects the balance of community priorities. In a democratic system, if the legal rules are followed, the decisions of the elected government can reasonably override the objections of a few protesters.

A Value Engineering style of analysis can be useful in refining options in relation to cost–benefit-based public sector developments and a possible questionnaire is shown in Fig. 14.1.

14.4 User Pays Principle

The User Pays principle is that those who use or benefit from a service should pay for it. Cost–benefit analysis involves variations from this principle, on the grounds that not all the issues are financially tractable, and that wider social benefits need to be considered. Nevertheless, it should be recognized that money represents a broadly based measure of “good” and a financial approach should not be abandoned too lightly. Anything that can reasonably be costed should be costed. The User Pays principle should be maintained as far as reasonably possible, though

in a cost–benefit situation this will often mean that the user does not pay the full price. The amount paid by the user acts as a regulator of demand, and also guards against frivolous use or misuse.

Payment rules should avoid creating situations where an organization has an open-ended commitment to provide a service at below cost. Cross-subsidization, that is assets or services being provided for one group but being paid for by another, should be kept to minimal levels. Some acceptance of cross subsidy is, however, likely to be involved in many cost–benefit cases. The term postage stamp pricing applies to cases where all users pay the same price for a service, even though the cost of delivery varies.

Some people are likely to have genuine loss of amenity and in this case compensation will be a reasonable issue. It will be necessary to evaluate the claims of vocal as against nonvocal groups and to deal with the NIMBY or Not In My Back Yard effect.

14.5 Activity-Based Cost–Benefit Analysis

Activity-based costing means relating costs for a product or service closely to the activities needed to support it. This is in contrast to a broad brush approach which allocates overheads in proportion to some simple measure such as direct man-hour content, even when a particular overhead may not apply to a particular activity. Activity-based costing is a way of accurately allocating of overheads to the activities they are used on, and not to others.

In activity-based costing, we

- Identify the “cost drivers” of each activity.
- Relate costs, and hence budgets and prices for these activities to the drivers.

Activity-based cost–benefit analysis (a term which I have just invented) involves identifying the cost and benefit drivers of each activity and using these as a basis for cost–benefit analysis. The focus of activity-based cost–benefit analysis is to avoid misallocating costs or benefits to activities to which they do not apply. This applies particularly to overhead or in-direct costs which can often be distributed across activities which do not require them. Equally, it applies to assigning those costs to areas which do require them. An example of an inappropriate cost allocation is applying bushfire insurance costs as a charge on all properties, regardless of whether they are in a bushfire prone area or not.

14.6 Lost Opportunity Cost

As well as the active options identified in a cost–benefit study there may be other opportunities which could arise. Thus if a sports center is *not* built in a certain place, it may be possible to sell the land and use the money for other benefits. It

can be argued that this then becomes an option in a normal sense, but it is important to consider lost opportunity aspects of the various scenarios.

14.7 Measures of Benefit

Quality-adjusted life-years is a concept used in evaluating the benefit of medical treatments to patients. Other measures correspond to the types of key performance indicators discussed in the section with that title.

14.8 Cost–Benefit Analysis Steps

Cost–benefit analysis proceeds through the following steps:

- a. State the objectives.
- b. Obtain basic information.
- c. Identify measures to be used in evaluating scenarios.
- d. Select scenarios.
- e. Include a base case scenario relative to which the costs and benefits are calculated. This is usually the “do nothing” scenario.
- f. Identify the stakeholders.
- g. Identify activities or events which impact on each stakeholder.
- h. For each stakeholder and activity identify the costs, benefits, and disbenefits.
 - i. Present the result as a Planning Summary Sheet.
 - j. Rank scenario options.
 - k. Recommend preferred option.

14.8.1 Activity-Based Cost–Benefit Summary Sheet

To illustrate the cost–benefit process and give an example of a summary sheet, consider the following cost–benefit example.

14.8.1.1 Example—Undergrounding of Electricity Distribution System

Residents in suburban city are interested in having their overhead electricity distribution system put underground because:

- The area is prone to occasional severe storms which cause extensive electrical outages;
- The streets look better without overhead wires (amenity value).

A study of undergrounding options for the city has been found as follows. Eighty percent of the area is on sandy soil where undergrounding is relatively cheap. The cost of undergrounding this area has been estimated at \$3,000,000. The cost of undergrounding the remaining 20 % which is on rocky ground would be \$4,000,000 which is considered prohibitive. Undergrounding reduces the frequency of outages significantly in the area undergrounded, marginally in adjacent areas and slightly in other areas.

Prepare a cost–benefit summary sheet for a scenario where the 80 % area is undergrounded with the \$3,000,000 cost being met as follows:

City council \$1,000,000

Electricity company \$1,000,000

State government \$1,000,000.

14.8.1.2 Solution

The conclusion from the cost–benefit analysis is that the residents in the undergrounded area are the significant benefactors, particularly in regard to amenity. Most of the cost is paid by others, but it is spread quite thinly. The city residents were willing to bear their share of the cost for the sake of the amenity value.

In the example of Table 14.1 only one scenario is shown. There could be other scenarios, for example with less or more of the city undergrounded or with the costs distributed in some other way.

Also, for each stakeholder there can be multiple activities, to be shown in a separate activities column, each with its own costs and benefits. The Regional Health Clinics exercise gives an example of this.

Table 14.1 Cost–benefit summary sheet

Stakeholder	Cost	Benefits/disbenefits
Residents in undergrounded area	\$800,000 (via city rates)	Amenity
		Significantly reduced outage frequency
Residents in non-undergrounded area	\$200,000 (via city rates)	Marginally reduced outage frequency
Electricity consumers	\$1,000,000 (via electricity bill)	Slightly reduced outage frequency
Electricity company	Nil (cost is passed on to consumers)	Slightly reduced outage frequency
State tax payers	\$1,000,000	Nil
Total cost	\$3,000,000	

14.9 Regional Health Clinics Exercise

A regional health organization is facing increased demands for services. At present, there are four small clinics in separate locations. Users are asking for reduced waiting times and for a greater range of services. There is local concern that government may close some clinics in order to save money.

In fact, government is willing to spend more money but requires a cost–benefit analysis as an input to planning. Give an outline cost–benefit analysis in dot point form. Factors include the following:

- Large clinics can have more facilities.
- Attendees at clinics include significant numbers of parents with young children.

Options are:

1. Retain the four small clinics as they are at the existing locations. This option includes some minor improvements at each site and is the base case.
2. Create a large central facility and close the other clinics.
3. Create an intermediate-sized central facility and retain three existing clinics in their present form, with minor improvements.

A solution in dot point form is in the exercise solutions section.

14.10 Regional Health Clinics Exercise Solution

Objectives

- Increase service capacity
- Improve range of services
- Maintain access

Basic Information

- Numbers of existing treatments and trends
- Demographics
- New treatment options projected

Evaluation Criteria

- Cost
- Capacity provided
- Range of services provided
- Accessibility

Scenarios

1. Retain the four small clinics, and make minor improvements to each clinic at its existing location.
2. Create a large central facility and close the other clinics.

3. Create an intermediate-sized central facility and retain three existing clinics in their present form, with minor improvements.

Costs/Savings—for each scenario

- Capital costs: Land purchase, construction, relocation, and refurbishment (existing locations)
- Sale of property if clinics closed
- Operating costs: Staff and building maintenance
- Travel costs: For members of the public to each location.

Qualitative

- Improved range of services at major clinic
- Improved staff working conditions at major clinic
- Travel time and inconvenience for public if clinics closed.

Ranking

- The cost analysis favored the creation of a single central clinic.
- Disbenefit of closure of local clinics, causing travel problems for families, was considered to be a significant factor.
- Option 3 was selected, with intermediate development at central location and minor improvement of existing clinics (Table 14.2).

Table 14.2 Activity-based cost–benefit summary for clinics

Scenario	Stakeholder	Activity	Benefits	Disbenefits	Costs/savings
1. Four small clinics	All	All	Base case	Base case	Base case
2. One large clinic only	Patients	Minor treatment	Nil	Travel required	
	Patients	Major treatment	More services	Nil	
	Government	Buildings, equipment, operating			Development cost minus sale value of small sites
	Staff		Better conditions	Nil	
3. Medium clinic plus three small clinics	Patients	Minor treatment	Nil	Nil	
	Patients	Major treatment	Some more services	Nil	
	Government	Buildings, equipment, operating			Development cost
	Staff		Some conditions improved	Nil	

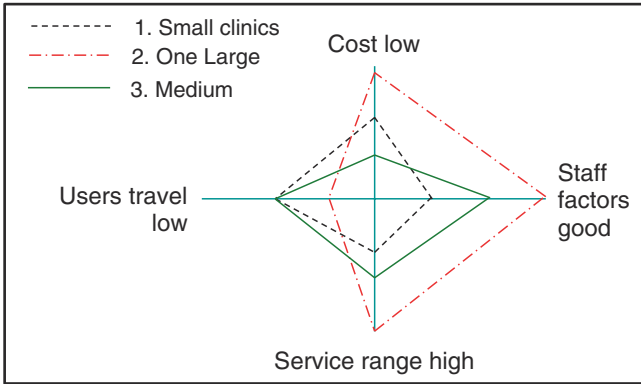

Fig. 14.2 Cost–benefit spider diagram for health clinics

14.11 Cost–Benefit Spider Diagram

The factors in a cost–benefit analysis may be represented in a spider diagram. Figure 14.2 shows a diagram for the Regional Health Clinics Exercise. Four factors are illustrated. More distance from the center represents a good outcome. The upward line represents cost, with lower cost being further from the center. The cheapest option is Option 2 because the income from sale of the unused sites and the economies of scale at a single site more than offset the cost of developing the large site. Option 3 is the most expensive because no sites are sold but there are more development costs than for Option 1. Users travel is the same for Options 1 and 3 but higher for Option 2. Option 3 is relatively expensive but has the benefit of an improved service range at the main location without major impact on user travel.

Chapter 15

Risk Analysis and Risk Management

The risk in a project is proportional to the square of the hype associated with it.

Abstract This chapter introduces the concept of risk, gives references to standards and major documents which deal with risk, and defines terms relating to risk. The procedures in the management of risk are then outlined and the legislative approach to risk is discussed and illustrated by an example. Various types of risk are described, and hazard analysis and the assessment of consequences are discussed. Factors in mitigating risk and contingency planning are presented. The chapter concludes with an example of risk analysis and management in a water supply system. Risk considerations in safety critical plant are addressed in the separate chapter under the title of “Safety.” *Outcomes* After reading this chapter you will know how to analyze and treat risk. This will include an awareness of the legal approach based on meeting duty of care and regulatory obligations, and the analysis and assessment of risk in relation to projects and to plant and machinery. You will be aware of techniques of hazard analysis, the assessment of consequences, the use of contingency allowances, and of methods of mitigating risk. You will have seen how risk analysis was used in a water supply system application.

15.1 Aim

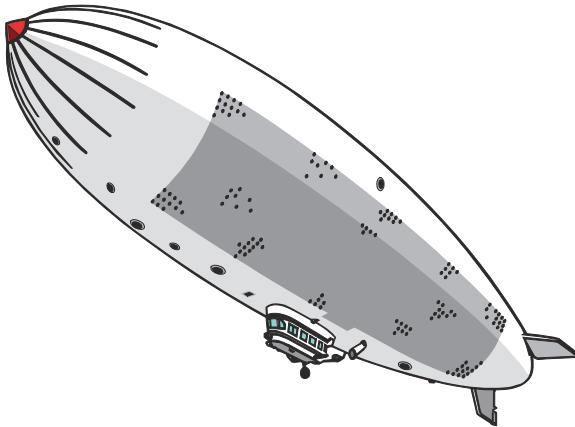

The aim of risk analysis and risk management is to address four fundamental questions:

- What can go wrong?
- How likely is this to happen?
- What are the consequences if it does?
- How can the likelihood and consequences be reduced or mitigated?

Risk is a very broadly based concept, and one whose range has expanded in recent times to cover everything except a racing certainty. There is a strong emphasis on risk in the ISO 55000 Asset Management standards.¹

15.2 References

The following documents deal in detail with the issue of risk in a variety of contexts.

- ISO 31,000 Risk management—Principles and guidelines.
- ISO 31,010 Risk management—Risk assessment techniques.
- ISO/IEC Guide 73, Risk management—Vocabulary—Guidelines for use in standards.
- AS 3931 or IEC 60300-3-9. Risk analysis of technological systems.
- IEC 61882. Risk analysis in chemical plants and other high risk environments: HAZOP—Hazard and Operability Studies. Hazard and Operability Studies Application Guide.

¹ ISO 55001 Clause 6.1 ‘Actions to address risks and opportunities...’ “The organization shall plan actions to address risks and opportunities....”

- API 580 and API 581 Risk-Based Inspection. Oil and gas industries. There are many publications and training programs from the American Petroleum Institute.
- Lees' "Loss Prevention in the Process Industries" published by Elsevier, (3 volumes) provides a comprehensive cover of risk.
- ISO 22,000, Food safety management systems—Requirements for any organization in the food chain.
- Hazard Analysis Critical Control Point—HACCP is a system which identifies, evaluates, and controls hazards in the food industry. It is used internationally to provide assurance that food is safe for consumption. Guidelines are issued by the Codex Alimentarius Commission.

15.3 Risk Analysis

Risk analysis is concerned with identifying risks and assessing potential likelihood and consequences. Events can have favorable as well as unfavorable consequences, for example, a construction project may encounter good or bad weather. Risk analysis should assist us to avoid adverse effects, and to be prepared to deal with them if and when they do occur. Risk assessment involves a willingness to consider possibilities which we would rather not consider.

Over zealous commitment to a project and the wide engagement of senior personnel and high-level stakeholders make it harder to admit and avoid risk. Had the voyage of the Titanic not been such a high-profile event, it is most probable that the ship's captain would have slowed down and not hit an iceberg at fatal speed.

15.4 Definitions

ISO Guide 73 defines a range of terms relating to risk. The following are key terms:

Risk the chance of something happening (an event) that will have an impact on objectives.

Hazard a source of potential harm.

Consequence the outcome of an event in the form of loss, gain, disadvantage, advantage, or injury.

Likelihood a qualitative description of probability or frequency of occurrence of an event.

15.5 Management of Risk

Risk management involves recognizing risk and taking steps as may be necessary to reduce the potential effects. This involves the creation of roles, responsibilities, and authorities in relation to risk.

Fig. 15.1 Risk management outline

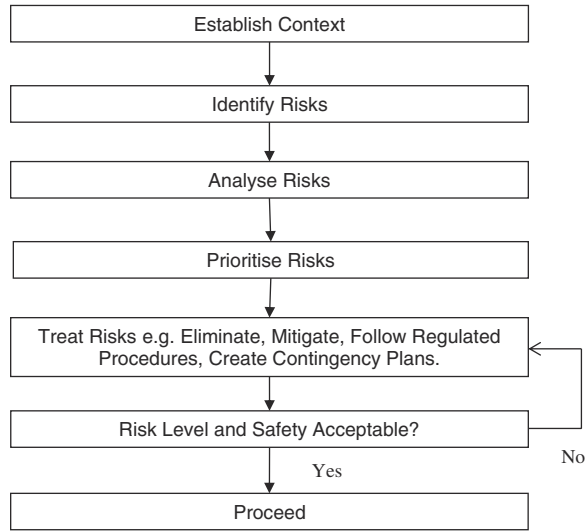

In practice, this means that a hazard analysis is undertaken in which we make a list of the risks, known as a risk register. We then analyze the risks, considering their significance and how they may be overcome or mitigated. We then create the necessary controls, procedures, and contingency plans. A general outline of the procedure is shown in Fig. 15.1, which is based on diagrams in the standards previously cited.

In setting roles, responsibilities, and authorities, the general principle is that managers with budgetary authority over an area have responsibilities for risk in that area. This is because budgetary authority is required in order to take the steps necessary to address any risk issue.

Specialist advice is also likely to be required in relation to technical functions and specific hazards. For this purpose, we may create a company-wide risk assessment team which specializes in understanding the types of risk that occur in the business. This can be a task of the asset management group, or the relevant asset manager, but it is also important to engage local operations personnel. Specific equipment specialists, legal liability specialists, and health, safety, and environmental specialists may be involved as necessary. The risk assessment team advises on the analysis of risk, risk mitigation activity, and contingency plans and recommends funding support to the regular budgetary authority, such as a plant manager.

15.5.1 Risk Management Documents

To manage risk, appropriate documentation is required. Key documents are:

- Risk Management Policy Statement;
- Risk Register showing identified risks and risk ratings;
- Risk Treatment Schedule and Plan; and
- Risk Action Plan.

Examples are given later in this chapter.

Fig. 15.2 Take 5 Risk management process

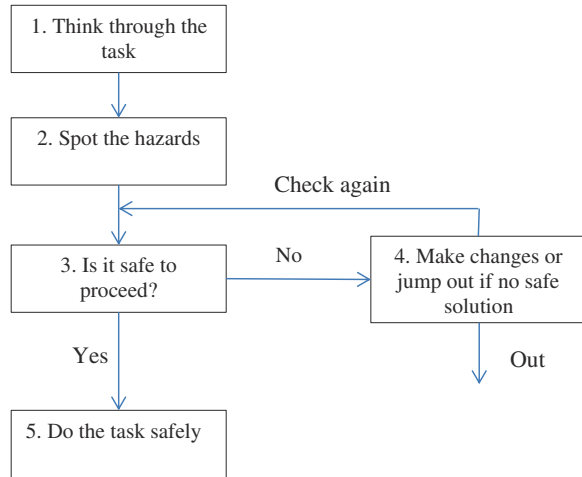

15.6 Take 5²

Take 5 is a technique aimed at encouraging the widespread adoption of risk management, by summarizing the process in a simple form. In the Take 5 process, the individual reviews the job, the workplace, the system of work, and the work environment immediately prior to starting a task. The individual is responsible for the decision to proceed with the task or not, based on the Take 5 process outcomes. If it is unsafe, the task must not be started. Figure 15.2 shows the step by step process.

15.7 Legislative Approach

The legal approach to risk centers on meeting the requirements of existing legislation, existing standards or, in the absence of these, of good practice. It is important to be aware of legislation and related standards which apply to your activities, and to comply with these. The documents listed earlier in this chapter form a useful starting point, and some other relevant standards are listed in the Standards section at the end of this book.

A *duty of care* exists (under Common Law) where there is a foreseeable and predictable cause and a hazardous effect and where it is practicable to remove the cause or control the effect. If a zoo keeps a tiger, it is up to the zoo to ensure that the tiger does not get out and kill someone. Conforming to an appropriate regulation can provide a legal defense in a prosecution for breach of an obligation. Where there is no defined regulation, you must be able to show that you took

² BHP Billiton Western Australia Iron Ore Health and Safety Take 5.

reasonable precautions and exercised due diligence in managing exposure to risk. If the procedures associated with the precautions are not documented, then they do not exist!

Maintenance specified by a manufacturer must be carried out unless a convincing reason otherwise can be presented. The maintenance that is carried out must be recorded. Regulations applying to the design or operation of equipment must be complied with, and good practice must be followed in regard to issues such as operation and supervision by competent persons. This will often extend to the assessment of equipment condition by technically qualified staff.

Figure 15.3 illustrates the issue of satisfying a duty of care in an application involving an electricity cable. A contractor digs up and severs the cable causing damage and disruption to businesses. The contractor argues that the electricity company which owns the cable has failed in its duty of care. The duty of care of the electricity company covers four regulated features;

- marking the position of the cable;
- placing it at the correct depth;
- aligning it correctly in relation to nearby buildings; and
- providing protection in physical and electrical terms (e.g., circuit breakers).

Fig. 15.3 Satisfying a duty of care

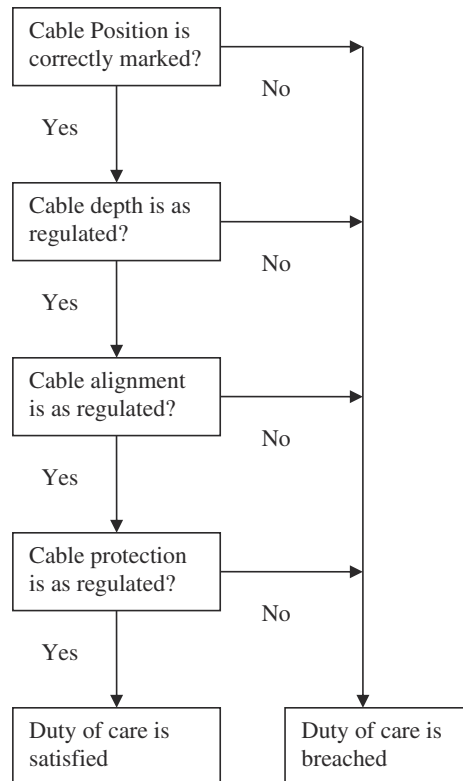

If the electricity company has carried out these duties correctly, it will have a presentable defense against the contractor's arguments.

15.8 Types of Risk

15.8.1 *Sovereign Risk*

Sovereign risk is risk associated with high-level events outside your organizational control, particularly those involving government actions.

- Government changes the law, the regulatory rules, or the level of subsidies after you have invested;
- Political change of sentiment;
- War and peace.

Sovereign risk may be offset by *force majeure* clauses in a contract which specify that certain risks are excluded from the contractor's liability.

15.8.2 *Solution Risk*

Solution risk is where the expected solution to a problem, or the technology underlying a project, turns out not to work or to be prohibitively expensive. Solution risk is easy to overlook or underestimate. Many major losses have occurred because the wrong solution was selected for a development. Project managers should be aware of this issue and avoid excessive commitment to a solution which is in fact unproven. If in doubt, undertake a pilot study or do more research.

15.8.3 *Technical Development Risk*

Development work is notoriously risky. Assumed technical progress is often not realized. Projects involving software, combining software and hardware, or integrating of two or more systems are particularly difficult. It is advisable to regard development strictly as development, and not to jump into a production phase before a concept is proven.

15.8.4 Performance Risk

The performance resulting from development may prove to be unsatisfactory. Production or support aspects of a development may prove unsatisfactory, or new developments may overtake the original concept.

15.8.5 Commercial or Financial Risk

Sales may not be realized—fewer buyers or users may appear than forecast. The profit margin will then be eroded by lack of sales. Competition is another factor that can depress sales. Costs may be higher than forecast, leading to an eroded profit margin. Anticipated capital funds may not become available.

15.8.6 Administrative Risk

Risks can arise from events inside your organization but outside your project. Other departments do not commit; there are delays in or lack of approvals, and delays in, or nondelivery of, related activities needed for your project. A rendez-vous is a weakness in a plan.

15.8.7 Safety and Environmental

Safety and environmental impact are often risk factors. Extensive legislation and procedures relating safety and environmental protection are normally specified for any hazardous industry or occupation and the relevant rules must be identified and followed. Safety is discussed further in the chapter with that title.

15.8.8 Supplier Risk

A supplier may fail to deliver, or there may be delay in delivery. There may be changes to pricing or level of support.

15.8.9 Resources

Physical facilities or human resources in design, development, acquisition, production, operations, or sales may fail to eventuate.

15.9 Hazard Analysis

Hazard analysis means considering all the things that might go wrong and making a list of them. This is a basic step in addressing risk. Hazard analysis should be carried out by persons with a thorough knowledge of the plant or service characteristics and methods of operation—steady-state and transient. Formal processes have been developed and extensively documented to assist with hazard analysis, including the following. References are given in the references section at the beginning of this chapter.

- Hazard Identification (HAZID)
- Hazard and Operability Analysis (HAZOP)
- Failure Mode and Effects Analysis (FMEA)
- Risk-Based Inspection (RBI).

15.10 Consequences

A *consequence* is the result of an adverse event occurring. Consequences associated with risk include the following:

- loss of business, at minor or major level;
- legal liability and costs;
- loss of reputation;
- lost production;
- project failure;
- project delays or additional costs;
- emergency service costs;
- repair costs;
- secondary damage;
- adverse environmental impact;
- injury; and
- loss of life.

Figure 15.4 illustrates an adverse consequence of risk.

15.11 Risk Analysis and Risk Rating

Risk analysis is an assessment of the seriousness of the risks that we have identified. As part of the analysis, we consider any existing controls that may be applied and the effectiveness of those controls.

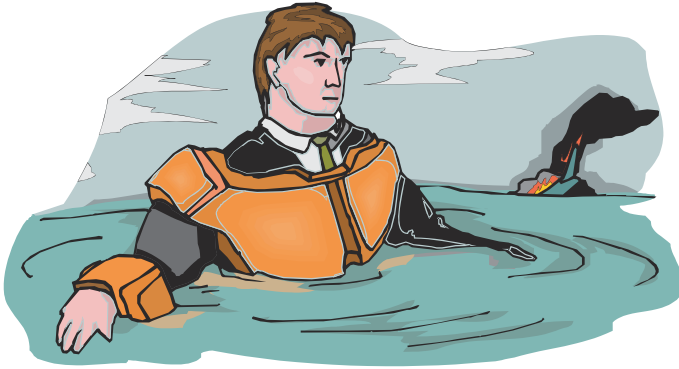

Fig. 15.4 An adverse consequence of risk

At its simplest, risk analysis may be done by a direct judgment approach in which we rate and rank the risks. We then proceed to consider how we might reduce or mitigate those risks that we have judged to be sufficiently serious to warrant attention.

A more structured approach is to apply qualitative scales to assess the likelihood of each risk the consequences if it occurs. The likelihoods and consequences are then combined to determine a risk rating. Table 15.1 Risk Level Matrix, shows the approach. This is based on the type of risk matrix in IEC 30010.

15.11.1 Risk Matrix

In Table 15.1 the following qualitative ratings are used. An alternative is to use 1–5 numeric ratings.

- *Likelihood* Rare, Unlikely, Moderate, Likely, and Almost Certain
- *Consequence* Insignificant, Minor, Moderate, Major, and Severe
- *Risk Rating* Low, Medium, High, and Extreme.

Table 15.1 Risk level matrix

Likelihood	Consequence				
	Insignificant	Minor	Moderate	Major	Severe
Almost certain	Medium	Medium	High	High	Extreme
Likely	Medium	Medium	Medium	High	Extreme
Moderate	Low	Medium	Medium	High	High
Unlikely	Low	Low	Medium	Medium	High
Rare	Low	Low	Low	Medium	Medium

We may then specify that the various levels of risk call for action to be taken at suitable levels of management and within suitable time scales, such as the following:

- *Extreme* Immediate executive action is required
- *High* Executive action is required
- *Medium* Management assignment of action and responsibilities is required
- *Low* Manage using routine processes.

15.11.2 Consequence Ratings

In manufacturing applications, the consequence rating options might take the following form:

Consequence ratings

- Insignificant,
- Customer complaint,
- Product recall,
- Serious illness/injury,
- Fatality.

15.12 Risk Register

Each identified risk should be entered into a risk register. The format may vary with the various techniques. For each risk identified, a risk register records such factors as:

- source;
- nature;
- existing controls;
- likelihood and consequences;
- initial rating; and
- vulnerability to change.

15.13 Mitigating Risk

The primary reason for considering risk is in order to avoid undesirable consequences. This means that we need to take steps to eliminate, mitigate, or reduce risk.

It is often not possible to eliminate risk entirely, and in this case the aim will be to substantially reduce risk. One approach to this is described as reducing risk to a level which is As Low As Reasonably Practicable (ALARP). An alternative terminology is that risks should be reduced So Far As is Reasonably Practical (SFAIRP). There is debate about how different these approaches are. ALARP may be said to imply some form of numerical estimation of the remaining risk. SFAIRP is described as “precautionary,” meaning that evident precautions should be taken, without implying that numerical estimation is involved. The precautionary or SFAIRP approach appears to carry more legal weight.

At the general business level, some techniques which we may use to reduce risk are as follows:

- Risk identification to create awareness and good practice.
- Creating and implementing plans to reduce risk.
- Adopting safety precautions.
- Contingency planning.
- Contract terms to limit business risk.
- Using the skills of a group of experts to assess risk and mitigate risk.
- Use skills of experienced estimators and managers in creating and managing projects.
- Record and apply corporate knowledge of previous risks.

In the remainder of this section, we provide a brief resume of more technical techniques in the risk mitigation area, but note that it is important in practice to be aware of and follow the detailed techniques relevant to the actual situation of any particular industry or service.

15.14 Contingency Planning³

Contingency planning is making plans to be brought into effect if adverse conditions eventuate.

15.14.1 Contingency Allowance

Contingency allowances are a common way of allowing for risk in projects. Typically, 10–20 % contingency funds will be allowed in project budgets. The level depends on an assessment of the risks. Contingency allowances are best held on a central basis, as this allows for flexibility. However, the existence of contingency allowances should not be taken as a substitute for good management.

³ ISO 55001 Clause 6.2.2: “The organization shall ensure that...risks are considered...including contingency planning.”

15.14.2 Contingency Plan

An example from a contingency plan is shown in Fig. 15.5, which shows the locations to be adopted by crew members of a passenger ferry in the event of various types of emergency. Further detailed procedures for different circumstances would form part of the contingency plan.

15.14.3 Retirement of Risk

When a risk is no longer relevant, it should be retired from the analysis and any corresponding contingency allowance should then be discontinued. An issue that arises is whether, as contingency funds are retired, they should be applied to increasing capability within the same project or should be returned to higher levels for reallocation. In principle, return to higher level is the norm, but project managers often put forward strong and successful cases for using retired contingency to enhance their particular project.

15.15 Quantitative Risk Analysis

Quantitative risk analysis works in terms of a definition of risk as a probability.

Person	Fire	Collision	Mechanical Failure
Captain	Bridge	Bridge	Bridge
1st Officer	Direct fire fighting priorities	Assess and report damage status	Assess and report navigational status
2nd Officer	Report fire status	Monitor external danger	Monitor external danger
Engineer	Engine room	Damage site, direct action	Failure site, direct repairs
Assistant Engineer	Manage fire fighting	Engine room	Engine room
Crew	Fight fire	Repair activities	Repair activities
Radio Op.	Send alarm	Send alarm	Notify status
Chief Steward	Control passengers	Control passengers	Communicate with passengers
Stewards	Lifeboat stations	Lifeboat stations	Assist passengers

Fig. 15.5 Contingency plan for passenger ferry

Concepts in a quantitative approach are,

- *Probability of occurrence* The probability that an event occurs in some defined period or situation of risk.
- *Occurrence Rate* The average number of times an event occurs per year, or other time interval.
- *Risk-cost* The probability that an adverse event occurs multiplied by the cost if it does.
- *Risk-cost per year* The occurrence rate of events per year \times \$ cost per event.

Techniques for estimating risk-cost include the following:

- statistical analysis of failure and successful performance data
- “gut feel” based on experience and judgment
- use of event trees, or simulation.

Although risk-cost can be a guide to our thinking, the product of a very low occurrence rate multiplied by a very high cost does not always result in a meaningful number when related to conventional financial analysis.

The risk-cost of business liabilities can be difficult to assess. It is desirable to get senior management to make an assessment of potential risks and costs, as middle management can waste time and resources on excessively detailed studies, when a decision, say to replace or retain a certain group of old equipment, may be quickly made by a senior manager with a more overall view of the situation.

15.16 Other Methods⁴

Other methods of risk analysis involve a more analytical or detailed level of approach. These include:

- a. Analysis of reliability and maintenance data.
- b. Use scaling systems for factors such as event probability, severity, and detectability as in Failure Mode and Effects Analysis (FMEA).
- c. Application of hazard indices, see for example, Lees’ op cit, Volume 1, Chap. 8.
- d. Analysis of wear rates based on materials and operational temperatures and pressures, as applied in Risk-Based Inspection.
- e. Test and evaluation procedures, for example in estimating fatigue life or corrosion or degradation rates under specified conditions.
- f. Event trees.
- g. Fault trees analysis, described, for example, by J.P. Bentley, “Quality and Reliability Engineering”, Longman.
- h. Sensitivity analysis for various scenarios: Optimistic, Best Estimate, and Pessimistic.

⁴ An extensive list of risk analysis techniques is given in IEC 31010.

- i. Risk adjusted discount factor. The discount factor is increased to penalize risky investments.
- j. Simulation modeling including reliability block diagrams.

15.17 Project Risk Examples

These are some examples of risks in acquisition projects.

Machinery is being purchased from an overseas supplier whose technical documentation, operating procedures, and training manuals are in another language. A local contractor has been engaged to provide translation of the documentation, and adaptation to local technical and environmental standards. The possibility that the local contractor has bitten off more than he can chew constitutes a risk in the overall acquisition and deployment.

A number of complex machines are being made to order. Demand on the manufacturer for products generally is rising, and there is a risk that our production will be delayed. Although this will give rise to cost penalties, the negative impact on our company may be significant.

Equipment may fail acceptance requirements. This is always a possibility, but the position will become clearer from early results and supplier responses to problems.

15.18 Water Supply System Example

The following example, relates to the assessment of risk in a water supply system. The system involves pumping water from a river to supply an irrigation system and a town. A flowchart of the system is shown in Fig. 15.6. The heavy arrows indicate water flows.

The hazards were identified using the system flowchart and fault trees. The flowchart identified each component of the system, e.g., pumps, rising main, pipes, valves, channels, power supply, switchboard, control system, and communication system.

Fault trees were then used to identify possible faults in each component. Figure 15.7 shows an example.

For each possible fault, risk assessments were then made. The results were recorded on forms using the concepts suggested in the risk standards, although the actual form layouts were specific to the application. Examples of completed forms are shown in Fig. 15.8.

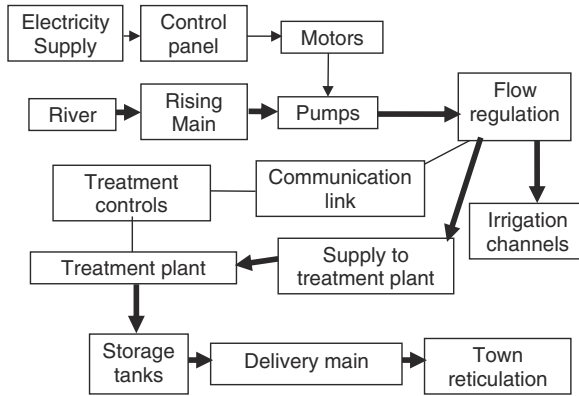

Fig. 15.6 Flow chart for water supply system

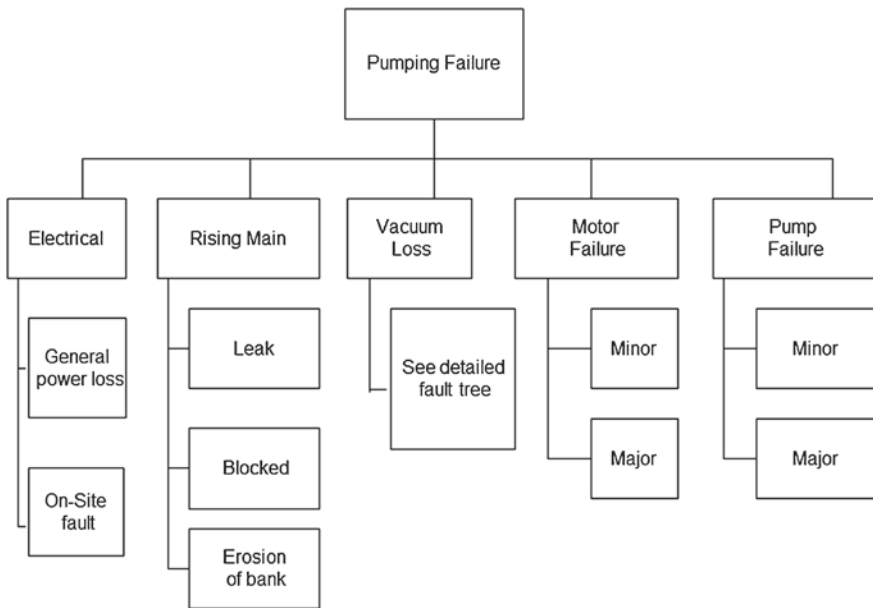

Fig. 15.7 Fault tree for pumping failure

Fig. 15.8 Hazard analysis risk ranking scale

0 =Zero
 1=Very Low,
 2=Low,
 3=Medium,
 4=High,
 5=Very High

15.18.1 Hazard Analysis

In this application, the fault or hazard rate assessments were based qualitatively on the scale shown in Fig. 15.9. The scale was refined by allowing noninteger values in the range 0–1 to reflect varying degrees of likelihood of rare events.

The nature of the risks was assessed under the headings:

- Safety,
- Cost,
- Function,
- Environment.

The consequences were assessed on the same 1–5 scale as Fig. 15.8, giving a risk rating under each heading. A risk rating was then calculated for each potential fault using the formula:

$$\text{Risk Rating} = \text{Hazard Rate} * (\text{Safety} + \text{Cost} + \text{Function} + \text{Environment}.)$$

For example at Ref. 3 of the Risk Register in Fig. 15.9, the following hazard analysis is shown:

1. Hazard is “Unable to Supply Water Due to Pump Failure”
2. Hazard Rate: 3 = Medium
3. Consequences:
 - a. Safety: 1 = Very Low
 - b. Cost: 4 = High
 - c. Function: 5 = Very High
 - d. Environment: 1 = Low

$$\begin{aligned} \text{Risk Rating} &= \text{HazardRate} * (\text{Safety} + \text{Cost} + \text{Function} + \text{Environment}) \\ &= 3 * (1 + 4 + 5 + 1) = 33 \end{aligned}$$

The highest score (worst case) is a rating of 100.

Mitigation for this hazard (pump failure) was to have a trailer-mounted standby pump available to cover a number of locations and applications.

15.18.2 Risk Treatment

Examples of a risk treatment analysis and risk treatment plans are shown in the second and third parts of Fig. 15.9. The example focuses on the risks associated with failure of the control switchboard of the water supply system. This is the hazard listed at Ref. 7 in the risk register on the first page of Fig. 15.9. In this study, the risk of loss of the switchboard, due to a fire, flood, or cyclone, for example, was considered significant, and a risk treatment analysis was developed.

Risk Register		Compiled by Revised by	NA/JH		Date			
Title	Irrigation System				Date	Date		
Ref.	Hazard	Current Controls	Rate	Safety	Cost	Function	Environment	Risk Rating = R*(S+C+F+E)
1	Unable to supply water due to leak in rising main resulting	None	2	1	5	5	1	24
2	Unable to supply water due to pipework seal failure.	Inspect annually	2	2	3	3	2	20
3	Unable to supply water due to pump failure	Routine maintenance	3	1	4	5	1	33
4	Flooding of property.	Operating procedures	1	3	2	2	2	9
5	Unable to supply treated water to town due to control failure.	Communication link	1	3	3	3	5	14
6	Unable to supply water due to switchboard minor failure.	None	1	1	2	5	1	9
7	Unable to supply water due to switchboard major failure.	None	1	2	5	5	1	13

Fig. 15.9 Water supply risk documents

Risk Treatment Schedule and Plan		Compiled by	NAJH	Date
Title:	Irrigation System	Revised by		23-Dec-00
Ref.	Hazard	Current Controls		
7.	Unable to supply water due to switchboard major failure.	None		
Treatment Options		Cost Benefit Summary		
A.	Upgraded fire detection and alarm system and regular thermographic monitoring.	A. Cost estimate \$20,000 plus \$3000 per year. May not entirely prevent failure.		
B.	As option A but with additional contingency plan with jury rig switchboard which can be activated in 6 hours.	B. Cost estimate \$30,000 plus \$5000 per year. Loss of supply for 6 hours may occur.		
C.	Keep standby switchboard.	C. Initial cost \$100,000. Also significant costs in maintaining duplicate board as system develops.		
Implementation Recommendation:		Option B.	Initial Rate	Revised Rate
Person responsible:		Northern Engineering Manager.	Safety	0.2 Safety
Action Plan Reference:		AP 4/2000	Cost	5 Cost
Timing:		To be in place by 1 July 2001	Function	5 Function
			Environment	1 Enviro
			Risk Rating	2.6 Risk Rating
				0.26

Fig. 15.9 (continued)

Risk treatment analysis considers the options for treating the various risks. An *action plan* documents the management controls to be adopted and lists the following information:

- Who has responsibility for implementation of the plan.
- What resources are to be utilized.
- Budget allocation.
- Timetable for implementation.
- Details of the mechanism and frequency of review of compliance with the treatment plan.
- Urgent repair or replacement.
- Nonurgent repair or replacement.
- Plant redundancy.
- Insurance spares.
- Contingency plans.
- Condition assessment and monitoring.

15.18.3 Monitoring and Audit

Monitoring and audit records should document:

- Details of the mechanism and frequency of review of risks and the risk management process as a whole.
- The outcomes of audits and other monitoring procedures.
- Details of how review recommendations are followed up and implemented.

Risk tends to increase as items enter the wearout phase. This is due to the long-term degradation of materials such as decay of plastics and other insulating materials, rust, wear, vibration, fatigue, creep, and physical impact. Monitoring of risk should involve a review of current asset condition in relation to these factors.

15.19 Exercises

15.19.1 Self-Assessment Exercise 15.1

1. Identify four basic questions which risk analysis and management techniques are intended to address.
2. Give definitions of the terms Risk, Hazard, Consequence, and Likelihood.
3. Give definitions of Sovereign Risk and Solution Risk.
4. Identify four types of document used in the analysis and management of risk.
5. Identify four methods which can be used to reduce or mitigate risk.

15.19.2 Self-Assessment Exercise 15.1 Solution

1. *Identify four basic questions which risk analysis and management techniques are intended to address.*
 - a. What can go wrong?
 - b. How likely is this to happen?
 - c. What are the consequences if it does?
 - d. How can the likelihood and consequences be reduced or mitigated?
2. *Give definitions of the terms Risk, Hazard, Consequence and Likelihood.*
 - a. *Risk* the chance of something happening (an event) that will have an impact on objectives.
 - b. *Hazard* a source of potential harm.
 - c. *Consequence* the outcome of an event in the form of loss, gain, disadvantage, advantage, or injury.
 - d. *Likelihood* a qualitative description of probability or frequency of occurrence of an event.
3. *Give definitions of Sovereign Risk and Solution Risk.*
 - a. Sovereign risk is risk associated with high-level events outside your organizational control, particularly those involving government actions.
 - b. Solution risk is where the expected solution to a problem or the technology underlying a project turns out not to work or to be prohibitively expensive.
4. *Identify four types of document used in the analysis and management of risk.*
 - a. Risk Management Policy Statement;
 - b. Risk Register showing identified risks and risk ratings;
 - c. Risk Treatment Schedule and Plan; and
 - d. Risk Action Plan.
5. *Identify four methods which can be used to reduce or mitigate risk.*

Any of the following:

 - a. Risk identification to create awareness and good practice.
 - b. Creating and implementing plans to reduce risk.
 - c. Adopting safety precautions.
 - d. Contingency planning.
 - e. Contract terms to limit business risk.
 - f. Use skills of experienced estimators and managers in creating and managing projects.
 - g. Record and apply corporate knowledge of previous risks.
 - h. Delphi technique. A group of experts are used to assess risk.

Chapter 16

Outsourcing

Abstract The aim of this chapter is to outline the main things to be considered by management in regard to outsourcing of asset management and maintenance work. Both positive and negative aspects of outsourcing are indicated, with the aim of helping managers to get the best value from their outsourcing options. *Outcomes* After reading this chapter you will know what type of tasks to outsource and what types are best kept in-house. You will learn about the types of outsourcing contract and about the points to watch for in creating and management of outsourcing contracts. You will also read about outsourcing from a contractor viewpoint, which will assist both parties to an outsourcing contract to achieve a favorable outcome. You will also read about forms of contract such as Build Own Operate Transfer and Public Private Partnerships.

16.1 Introduction¹

Civilization is based on specialization and specialization involves the devolution of work to those who specialize in specific types of task. Specialization enables an individual or an organization to be equipped, trained, skilled, and experienced in a chosen range of tasks, and potentially to execute those tasks efficiently and relatively cheaply. This is the rationale for outsourcing. At the same time, outsourcing introduces communication, negotiation, and pricing activities which must be set against the advantages of specialization.

Outsourcing of maintenance activities from utilities and large-scale enterprises has occurred on a substantial scale in recent years. To some extent this is a political issue, since large-scale enterprises suit the bargaining power of labor organizations. However, our concern here is with the practicalities rather than the politics of outsourcing.

¹ ISO 55001/2 Clause 8.3 Outsourcing: “The organization shall ensure that outsourcing processes and activities are controlled.”

16.2 What to Outsource

The basic reason for outsourcing work is that it provides a cheaper and/or better service than if we try to do the work ourselves. Besides cost, it may also be simply impractical for us to cover all the supporting activities needed by our business on an in-house basis. However, we need to be sure that there is a real cost saving, that it does not lead to a loss of quality, and that it does not come at an ultimately greater cost to our business.

16.2.1 Noncore Activities

The activities required to provide a capability can be divided into core and non-core activities. For example, in running a power station, the operation of the power plant itself and of the immediate engineering support can be regarded as core, whereas site activities such as:

- gardening
- cleaning
- security

are noncore. Noncore activities are ready candidates for outsourcing to organizations which specialize in the relevant functions, and which are likely to take on similar contracts with a range of organizations whose core businesses can vary widely.

16.2.2 Minor Player

Outsourcing also makes good sense for technical activities where our organization is a relatively minor player. Examples can include:

- Electric motor repairs
- Oil condition analysis
- Heating, ventilating, and air-conditioning maintenance

16.2.3 Peak Load Resources

Another common area for the use of contract resources is in the meeting of peaks in activity, such as maintenance personnel required for shutdown work.

16.3 The Owner/Operator Model

Another scenario is for an asset owner to appoint an operator who runs the entire operation. For example, a government entity may own a railway, but contract the operation of the railway to an operating company. We often find a multiple level structure in which the operator then subcontracts some functions to more specialized organizations. The general principle here is that a prime contractor should be responsible for his subcontractors. In what follows we refer to the owner or prime operator as an “outsourcer” and the organizations which are contracted to undertake particular types of task as “contractors”.

16.4 What NOT to Outsource

16.4.1 Core Activities

It is best not to outsource activities which are central to the business, or where the business has more specialist knowledge than the potential contractor. It is important to ensure that the potential contractor knows the business for which they are bidding.

16.4.2 High Customer Impact

Another area where companies should be cautious about outsourcing is for functions with high-customer impact. It is best to keep a close watch on these activities and to be able to pick up feedback and respond effectively and quickly to problems.

16.4.3 Problem Areas

It is best not to outsource activities which are currently causing a problem. Solve the problem in-house and then consider outsourcing once a satisfactory working solution has been found. Alternatively, if this is not possible, outsource the problem-solving activity on its own and then consider your position once a proven solution has been found.

16.4.4 Examples

A paper manufacturer outsourced the maintenance of its overhead cranes to a maintenance organization. But it turned out that the contractor, although

competent in maintaining mobile and construction cranes, had no experience in factory overhead cranes of the type used by the paper manufacturer and did not understand the necessity of maintaining strict alignment of the running rails, nor were they equipped to do this. After a couple of near accidents the company brought the maintenance of the overhead cranes back in-house.

In another example, a large insurance company was alarmed to find that only two people had a full understanding of the workings of their computer systems, and that both were contractors. They subsequently developed in-house skills and a succession plan.

16.5 Benefits of Outsourcing

16.5.1 Concentration on Core Business

Concentration on core business tends to benefit an organization, giving greater focus to essential activities and resulting in fewer direct employees, less fringe activities, and fewer birthdays to celebrate.

16.5.2 Redress Workforce Imbalances

Outsourcing can provide an opportunity to redress imbalances in the workforce. Organizations may have taken on workers in the past whose numbers, skills, and flexibilities are out of step with current requirements. Outsourcing provides an opportunity to review the workforce position from a zero base. Subsequently, it provides greater flexibility in meeting the needs of a changing business environment.

From the workers point of view, outsourcing can mean the loss of jobs. But many workers benefit from pursuing new lines of activity, and some find employment related to their original tasks, but on a basis that, given the increased flexibility involved, provides benefits for them as well as for their original employers.

16.5.3 Reduce Fixed Costs

Outsourcing can also have the benefit of moving fixed costs into variable costs. For example, maintenance and support equipment, is now provided by the contractor as an operating expense to the outsourcer. Keeping this equipment up-to-date is now an issue for the contractor, but as this is part of the contractor's main business, it is likely to be well managed and give economies of scale.

16.5.4 Review Maintenance Practices and Resources

In the maintenance area, outsourcing provides an opportunity to review and update maintenance practices. Formalizing a contract can create a clearer definition tasks and responsibilities. The contractor, who is likely to have responsibilities across a range of plant, can bring in economies of scale across the maintenance function. Paradoxically, an asset manager can sometimes find it easier to get good performance from a contractor, whose tasks are well defined and whose performance is under routine scrutiny, than it is to get the same performance from an in-house group.

16.6 Costs of Outsourcing

16.6.1 Formalization

One of the main reasons for establishing companies in the first place is to form a team with a collective aim and identity. Within the team, all are working for the same main ends. Cooperation between members of the team is the norm and requires minimal formalities. By contrast, outsourcing means that work is assigned to an outside organization and this means a contractual relationship which requires formalization to cover such things as:

- work scoping and specification
- costing
- identification of potential contractors
- tendering process
- selection process
- contract negotiation and agreement
- formal legalities
- contract management, including variations and cost control
- progress management and on-site activity control
- auditing of contractor performance.

This introduces cost elements which were not there when the work was done in-house.

16.6.2 Intangible Effects

Outsourcing can also have impacts of a less tangible nature. One such aspect is the loss of ability to direct workers, who now work for the contractor. For example, the manager of a hydroelectric generating utility, which operates a number of

small plant scattered over a mountainous area, reports that, prior to outsourcing he was readily able to identify and dispatch suitably skilled personnel to deal with problems at any site. Now he has to refer such problems to a contractor resulting in a loss of time and flexibility and an increased likelihood that the person dispatched will be unable to solve the problem.

16.6.3 Other Potential Negatives

Other negatives can include:

- Loss of critical skills and technical knowledge which go to the contractor and then to competitors
- Loss of employees that you did not intend to lose
- Loss of internal communication
- Less opportunity for knowledge growth and development of internal expertise
- Loss of links with suppliers—suppliers are now dealing with the contractor
- Hidden costs emerge—things that you did not realize your employees were doing
- The contractor looks good initially, but then shifts the best people to the latest client
- Delays in resolving crises, response time factors
- Lack of availability of particular necessary skills
- Loss of direct control over work timing
- Loss of direct control over work standards
- Cost of monitoring work done
- Inhibits continuous improvement
- Lack of commitment by contract personnel
- Lack of responsibility by contract personnel who will disappear and not be answerable for problems
- Potential for conflict between in-house and contract workers
- Security
- Access rights
- Insurance
- Handover of tasks/equipment between contractors and in-house personnel
- Ownership of items on site
- Contractors profit motive conflicts with the main company's overall interest
- Termination of contracts
- Ownership of improvements, developments.

This list may appear formidable, but airing the potential problems may go some way toward solving them. Ultimately, the benefits of outsourcing need to be sufficient to more than offset these many factors.

16.7 Types of Contract

Labor Only

Labor is hired and works as directed by in-house staff.

Time and Materials

The time taken and materials used are recorded and paid for at agreed rates. The contractor has no specific motivation to be economical, but this is not to say that he will be needlessly extravagant.

Survey and Quote

The contractor estimates the work required and then quotes a price for doing it. There will be checking by technical experts on behalf of the outsourcer. Often the same contractor then goes on to carry out the work.

Work Package

Labor, tools, and spares are provided to execute defined work.

Examples: Building contracts; Inspection and routine maintenance of fire safety system.

Lump Sum

The contractor agrees to maintain a system in return for an agreed sum of money. The maintenance policy details are left with the contractor. Level-of-service standards are defined.

Performance Based

Similar to Lump Sum except that the payment is adjusted (up or down) in accordance with agreed performance standards, such as:

- Availability of plant,
- Response time to failures,
- Keeping to schedule, and
- Turnaround time for rotables.

This is suitable for situations where the performance criteria can be readily defined. This is generally the preferred type of contract for operational situations.

Alliance

The outsourcer and the contractor work in an integrated way to achieve a target result. This type of contract may be necessary for projects involving technological development and/or systems integration. It is important that the outsourcer and the contractor agree on:

- Project target outcomes,
- Commercial incentives, and
- Intellectual property rights.

Conflicts can easily arise in these areas and on-going cooperative goodwill is necessary for success. Risks tend to revert to the outsourcer—be careful of this.

16.8 Contract Features

Some common features of outsourcing contracts are as follows:

- Performance criteria
- Level of service
- Incentives, bonus for good performance, and penalty for poor performance
- Availability of equipment or service by time and duration
- Security
- Access rights
- Continuous improvement—and partnering for improvements
- Ownership of intellectual property
- Insurance cover
- Contract termination options, procedure, and handover
- Ownership of equipment used
- Prime contractor to remain responsible for subcontractors, however, health and safety liabilities cannot be contracted out.

The contract must allow the contractor sufficient funds to cover costs, deliver a reasonable profit, and allow for contingencies. The nature and range of services must be well defined, and also the performance level.

Consider a contract for lawn mowing and edge trimming. The performance level should state how high the grass is to be in terms of a range! The choice of frequency of mowing is with the contractor, provided that the range of height is maintained, and may vary with the weather. Some fine details will need to be ironed out, for example, who is responsible for clearing the lawn of toys, and what rules govern the disposal of clippings.

Emergency response issues are covered in some contracts. Factors to be considered include the following:

- range of situations to be covered, definition of the emergencies,
- period for which covered,
- nature of response,
- time to respond,
- acceptable cost rules for dealing with emergencies, and
- exclusions.

16.9 Limiting Risks in Outsourcing

- The contractor must have necessary skills and management competence.
- Address sources of potential problems at the contract stage.
- Be prepared to stay with in-sourced solutions, or to revert to in-sourcing if necessary, particularly to cover urgent tasks, critical machines, or critical services.

- Keep links with affected employees.
- Use more than one contractor.
- Keep contracts to moderate length.
- Use performance-based contracts.
- Have contract provisions allowing you to react to an emergency by funding overtime, extra resources, or specific direction of resources to the emergency on hand.
- Primary contractor to have responsibility for their subcontractors. However, when problems occur, the contractor will still blame the subcontractors. It is advisable to involve the subcontractors in meetings and ensure that their opinions are heard and that they are party to all necessary information, without letting the main contractor pass off the risk.
- Create and retain in-house strength in:
 - Highly skilled technicians—have a minimal number and look after them
 - Asset management
 - Technical specialists
 - Contract negotiators
 - Contract managers and performance auditors
 - Customer support resources
- Succession planning is needed for all of the above
- Expect the contractor to make a reasonable profit, otherwise he may go out of business and you will be left to pick up the pieces.

16.9.1 Audit

An audit system should be established to check and report on contractor performance. This should compare actual service levels and other performance indicators against targets, and should check on performance of equipment in terms of reliability and availability.

16.10 Outsourcing Result

Outsourcing means that the outsourcer becomes an Asset Manager rather than a maintainer. There will be a need to continually deal with issues related to service delivery. *So hat jener seiner Sorgen*, to quote a German proverb.

If problems arise you can invoke the contract, but if the arrangements fail the problems revert to the outsourcer. You can outsource the task, but you cannot outsource the (ultimate) responsibility.

16.10.1 Example

The Victoria State Government outsourced the operation of part of its suburban railway network to a contractor. However, the contractor later walked away when they decided that they could not make a profit from the arrangement. The passengers still needed to be carried, however, so the problem landed back with the government. Fortunately, they had used another contractor for another part of the railway and they were able to get that contractor to pick up the slack. In these circumstances, the outsourcer often realizes that the original contract did not allow enough profit margin and is willing to make a more generous deal the second time around.

16.11 Contractor Viewpoint

Avoid sovereign risk, that is, situations where someone else (e.g., a regulator or government entity) can change the rules after your costs are fixed. Contract for a known service at a known cost. For example, contract for delivering system availability, rather than for operational utilization or actual sales revenue, or for any measure which depends on factors outside your control.

The contract must be sufficiently profitable in terms of the usual investment criteria and contain adequate provision to cover contingencies and to encourage further investment and growth. Identify risks, and ensure that the contract protects you against these as far as possible. Remember that politics can change and that public servants are interested (like the chicken providing the breakfast egg) but they are not involved (unlike the pig providing the bacon).

Consider business continuity. A one-off contract may require initial investment which requires significant continuity of business in order to recoup.

Consider payment terms and cash flow issues. Insist on being paid on time.

16.12 Build Own Operate Transfer (BOOT)

A contractor bidding to build a building will aim to provide value in terms of \$ per square meter. However, if the same contractor was also going to operate the building (e.g., residence, warehouse, and prison) the design would take more account of operational and maintenance factors. The owner should focus on through life costs of the entire operation and not just initial costs. BOOT contracts can assist in this process.

16.13 Public Private Partnerships (PPP)

Public Private Partnerships are arrangements whereby government and industry get together to work on a major project. Examples include roads, railways, and desalination plants. The reasoning behind these arrangements is that the public sector and the private sector each have different areas of strength, and bringing them together can produce an effective and timely result. The strengths which the different parties bring to a ppp are summarized in Fig. 16.1.

An example of a ppp is the building of a cross-city toll tunnel in Sydney. The tunnel was duly completed and the government and contractors were happy, but the public became resentful, because the government closed some alternative road routes and the toll charges were high. Public opinion forced the government to back down on some closures and charges. This led to legal conflict with the contractor and to the contractor losing money.

The positive side of ppp is that the project generally gets built! Without the cooperation of both sectors, the combination of political, financial, and technological delays can drag a project out over many years.

Expertise	Public Sector	Private Sector
Cost management		☺
Construction skills		☺
Technology skills		☺
Operation and Maintenance		☺
Finance	☺	
Land availability, access and approvals	☺	
Legislative changes	☺	
Environmental approvals	☺	
Political support	☺	

Fig. 16.1 Organizational strengths in public private partnerships

16.14 Exercises

16.14.1 *Self-Assessment Exercise*

1. What types of activities are suitable for outsourcing?
2. What types of activities should not be outsourced?
3. Identify four potential sources of benefit from outsourcing.
4. Identify five potential negative effects of outsourcing.
5. Identify five things that you might do to avoid risk in outsourcing.

16.14.2 *Self-Assessment Exercise Solution*

1. *What types of activities are suitable for outsourcing?*
 - a. Noncore activities
 - b. Activities where we are a minor player
 - c. Activities involving a peak load resource requirement
2. *What types of activities should not be outsourced?*
 - a. Core activities, central to our business where we have particular expertise.
 - b. Activities with high customer impact.
 - c. Activities which are currently causing a problem unless we know the solution.
3. *Identify four potential sources of benefit from outsourcing.*
 - a. Concentration on core business
 - b. Redress workforce imbalances
 - c. Reduce fixed costs
 - d. Review maintenance practices and resources
4. *Identify five potential negative effects of outsourcing.*
 - a. Any five of the things mentioned in Sect. [16.6.3](#)
5. *Identify five things that you might do to avoid risk in outsourcing.*
 - a. Any five of the things mentioned in Sect. [16.9](#).

Part V
Technical Areas

Chapter 17

Logistic Support

Abstract The aim of this chapter is to describe the factors involved in supporting physical assets from the point of introduction into service, over their lifetime through to disposal. These factors also influence the initial choice of equipment. *Outcomes* In this chapter you will learn that many problems in physical asset management can be reduced by considering the supportability of equipment at the acquisition stage. You will learn about the factors that need to be taken into account in planning equipment support, and will be provided with check lists to assist this type of planning.

17.1 Introduction¹

Physical assets require the support of people, services, and resources of many types, including operators, maintainers, repair facilities, consumables, spare parts, documentation, and training. To ensure that these supports are provided and budgeted for, several types of analysis are needed. The following techniques are applicable:

- Logistic Support Analysis—the detailed analysis of support requirements.
- Level of Repair Analysis—is concerned with deciding where particular types of repair will be carried out, for example, what will be done by local technicians, what by central workshops, and so on.
- Integrated Logistic Support—is a system for ensuring that, once we have decided on our logistic support concept, all aspects necessary to implement it are identified and implemented.
- Through Life Support—is a concept which emphasizes the need for logistic support to extend over the whole life of the equipment. This consideration is important where contracts for support are to be let.
- Supplier Viewpoint—Under this heading we consider the issue of logistic support from the point of view of a manufacturer or supplier, for whom both commitments and business opportunities exist.

¹ ISO 55000 Clause 2.4.2 “Asset management is based on a set of fundamentals” at (b) “This includes ... (3) the integration of asset management processes with ...logistics...”.

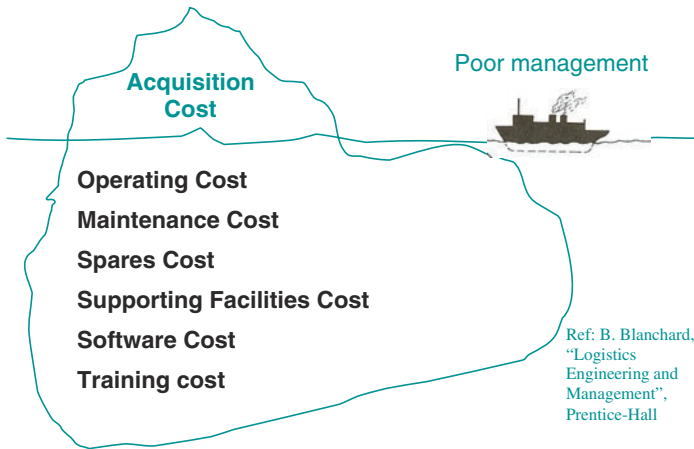

Fig. 17.1 Ice Berg diagram

The aims of these techniques are to:

- Form a basis for planning and budgeting for the logistic support of equipment from acquisition through operation to disposal—through life support;
- Take account of costs over the life cycle of equipment, and not just focus on minimizing acquisition cost.

In the case of common user equipment, purchased and used in an urban or industrial environment with many surrounding support services, the techniques outlined in this chapter are relatively easy to apply. This does not mean that the principles involved can be ignored or that it is impossible to go wrong. However, the available support of equipment distributors, manufacturers, and specialized maintenance organizations can greatly reduce the extent to which asset owners need to deal with the details of logistic support. By contrast, if we are to operate away from a supportive environment, great care must be taken to ensure that the essential logistic support elements are in place.

Figure 17.1, the Ice Berg diagram, based on the original by Ben Blanchard,² illustrates graphically the dangers of failure to recognize the activities and costs involved in logistic and through life support of physical assets.

17.2 Logistic Support Analysis (LSA)

Logistic support analysis is the determination of the equipment, people, and facilities required to support a given capability throughout its life. Logistic support analysis is designed to determine the “what, how, and where” of the provision of support

² Blanchard, Benjamin S, “Logistics Engineering and Management”, 4th ed, Prentice-Hall International.

resources and services for physical equipment. It is carried out in the early decision making phase of an acquisition plan. The aim of LSA is to ensure that our assets can be logistically supported in a practical and cost-effective way, and to define how this can be done. The analysis may influence the choice of the equipment itself, and will influence the nature and structure of our supporting services. LSA is concerned with:

- assessing the net maintenance and logistics load created by the asset,
- setting the maintenance and repair policies at a strategic level,
- establishing the extent and location of maintenance, repair, and overhaul facilities. This may involve decisions to outsource some or all of these tasks,
- costing for the above.

Logistic support analysis starts by identifying the type and quantity of assets involved, the utilization rate, and service level required. For example, with a vehicle fleet this will mean identifying the vehicle types, quantities, availabilities, and average kilometers run per year. At this stage we will also identify any special environmental or operational factors that affect our analysis. This can include climatic factors such as heat, cold, dust, or corrosive environments and operational factors such as equipment loading and planned equipment availability. In addition, we consider the extent to which new equipment will replace existing equipment, and the impact that this will have on the net requirement for logistic support.

17.2.1 Logistic Support Basic Data

In order to carry out LSA, basic data regarding the equipment to be supported must be established. This includes:

- Asset type
- Asset quantity
- Utilization rate or “rate of effort”
- Planned equipment availability
- Period of support or overall operation duration
- Specific environmental or operational factors
- Nature and quantity of equipment to be retired and the effect of this on support requirements.

17.2.2 Logistic Support Detailed Factors

LSA continues with an analysis of the logistics of operational support, including the provision, transport, and storage of consumables. This can be summarized as follows:

- Consumables by type
- Consumption rate
- Transportation

- Access
- Storage
- Shelf life of consumables
- Waste disposal

We then turn to a consideration of operation, maintenance, repair, and overhaul. Factors include the life of the prime equipment, the major assemblies or subsidiary items involved, the provision of maintenance facilities and of spare parts. Key points are summarized as follows:

- Planned life of main equipment
- LSA mission duration (e.g, provisioning of spares for first 3 years)
- Equipment criticality, reliability, and availability targets
- Test and evaluation criteria and standards
- Extent of in-house and/or outsourced support
- Major assemblies types and life
- Repair/Replace policy
- Spares and Rotables requirements
- Level of repair policy
- Maintenance facilities
- Maintenance labor requirements
- Support and test equipment
- Operator training and training facilities
- Maintainer training and training facilities.

17.3 Level of Repair Analysis (LORA)³

Level of Repair Analysis is concerned with determining maintenance policy. This will involve repair or replace policy and where various maintenance activities are to be carried out, so that appropriate staff and facilities can be provided.

Technical and economic considerations are used to determine whether an item should be repaired or replaced upon its failure, and in the case of repairs, to determine at which location the repair will be carried out.

For example, an electricity transmission company was planning the acquisition of a new radio communication system for use by field repair teams. Following a LORA, the maintenance policy adopted was that only first line repairs would be carried out by the company. These consisted of performance checks, setting adjustments, and complete unit or subunit replacements. No second or third line work was to be carried out by the company. A support contract was made with the supplier to accept any items requiring deeper maintenance and to provide refurbished or new replacement items within an agreed turnaround timeframe.

³ Level of repair analysis US-MIL-STD-1390D.

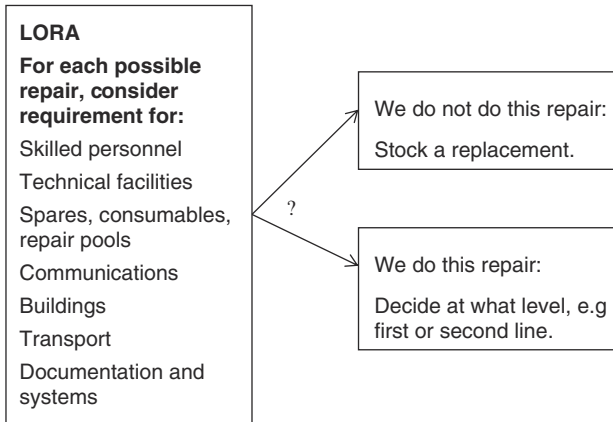

Fig. 17.2 Level of repair analysis

In general, LORA is used to determine at what level of the organization maintenance work will be carried out for each preventive maintenance activity and in response to each failure mode. Figure 17.2 illustrates the type of factors involved in a level of repair decision.

Figure 17.3 shows the overall position as we decide what work is to be carried out at each level for the fleet as a whole, and the resources and facilities needed at each level. LORA analysis provides the basis from which we can estimate the type and volume of work which is required at each level of repair. This then determines where we locate resources (e.g., test and repair equipment), and where to stock spare parts. To evaluate an entire system from scratch, including costing all options is a considerable task. In practice, for any particular acquisition we can usually draw on experience from similar or existing equipment, although this does not mean that we should not fully consider the options and how developments of equipment and technology impact on the development of logistic support.

17.3.1 Levels of Repair

The different levels are as follows:

17.3.1.1 Operator Maintenance

Operators should have some responsibility for, and ownership in, the equipment which they operate.

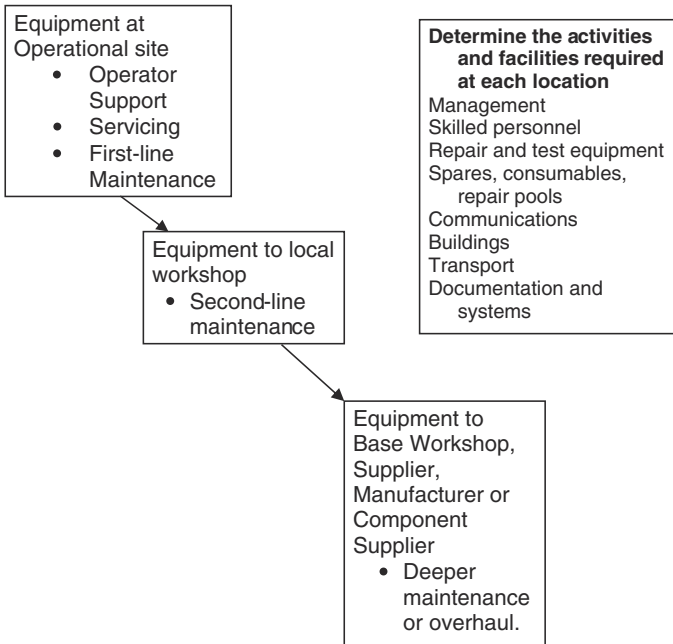

Fig. 17.3 Logistic support and level of repair elements

17.3.1.2 Servicing

Estimate the routine servicing load and provide resources.

17.3.1.3 First Line Maintenance

Plan the range of repairs to be carried out at first line, that is at the user area, with local technical support, diagnosis, and troubleshooting. Estimate the numbers and type of tradespersons to be located with users, and the spares, tooling, documentation, and training required.

17.3.1.4 Second Line Maintenance

This provides workshop facilities in a general location to support major plant, or as a support facility for plant scattered over a geographical area. Consider any particular repairs or system changeovers that will be carried out at this level and determine the corresponding requirement for facilities such as heavy lifting equipment, major welding, machining or chemical treatment, specialized technical skills, repair, testing, and monitoring. A workshop normally acts as a

base for recovery teams, emergency response teams, and field repair teams and for more specialized trades such as instrument, electronic, or communications specialists.

17.3.1.5 Third Line or Base Maintenance

This provides in-depth facilities, e.g., overhauls, and may be provided by a equipment manufacturer, a supplier, or a contractor.

17.3.1.6 Rotables

Rotables are components which are sent away for repair and then returned. Level of repair analysis involves considering whether some components should fall into this category and in making arrangements for the repair process.

17.3.1.7 Example

For a vehicle fleet, the type and quantity of vehicles and the planned utilization will form a basis for estimating the amount of servicing and first and second line repair work which will be required per year. From this data we can decide whether a dedicated vehicle servicing facility is required, whether to provide and staff this in-house at a specific location, or whether to let an outsourcing contract. We can also estimate the requirement for workshop facilities, in-house or outsourced.

17.4 Integrated Logistic Support (ILS)^{4,5}

Integrated Logistic Support is a system for ensuring that all items and services necessary to implement the support of items are identified and arranged for. Integrated Logistic Support is a follow-up to LSA. ILS uses formal check lists as an aid to identifying the items to be supplied and checked as satisfactory before the equipment is formally accepted by the user.

Integrated Logistic Support starts from the list of assets forming the capability, noting the amount of equipment involved, and the utilization rate. For example, with a vehicle fleet this will mean identifying the vehicle types, quantities, and average kilometers run per year. Figure 17.4 indicates the scope of factors covered by ILS.

⁴ US MIL-STD-1388-2B Integrated Logistic Support.

⁵ IEC 60300-3-12 Integrated Logistic Support.

Equipment outline description, sketch/Flow chart/Outline drawing.
Equipment acquisition timings and allocation to sites
Installation plan
Configuration List.
Supplier and Contractor Details.
Transport Plan
Site Preparation Plan
Disposal Plan
Operations
Operator Staffing Requirements and Plan
Operating Manual
Operator Training Plan
Operator Training Materials
Consumables Specification and Pricing
Consumables Provisioning Plan
Consumables Storage Plan
Consumables Disposal Plan
Engineering
Technical Documentation and Drawings
Technical Data
Safety Plan
Engineering Support Plan
Engineering Training
Maintenance Support Plan
Maintenance Policies for each Level of Repair:
Operational
Intermediate
Depot
Maintenance Procedures and Workshop Manuals
Repair Plan for Repairables (Rotables, Repair Pool)
Repair / Replace Policy
Maintenance Staffing Plan
Maintenance Training Plan
Support and Test Equipment
List
Provisioning and Installation
Test Specifications
Bill of Materials
Spare Parts Catalogue and Pricing
Spare Parts Provisioning Plan

Fig. 17.4 Integrated logistic support factors

17.5 Logistic Support Plan

The end result of the LSA is a logistic support plan which states how the logistic support elements required by the equipment are to be provided. The plan defines responsibilities for:

- a. testing and evaluation criteria for acceptance;
- b. packaging, handling, storage, and transportation;
- c. transport vehicles, four wheel drives, vans, and trucks;
- d. engineering support;
- e. consumables provision and transportation;
- f. repair, maintenance, and overhaul support;
- g. spare parts provision, storage, and information system;
- h. recovery vehicles and crews;
- i. provision and training of operators and maintainers;
- j. workforce accommodation and recreational facilities;
- k. technical data provision and management;
- l. configuration management;
- m. workshops, site offices, compound, plant yard, and covered storage;
- n. cranes, fork lifts, and handling equipment;
- o. electrical power provisions;
- p. water supply and treatment if necessary;
- q. support facilities and test equipment;
- r. occupational, health, and safety issues;
- s. environmental issues;
- t. waste disposal facilities;
- u. disposal of equipment which is replaced.

17.6 Through Life Support

The through life support of assets is provided by support systems which cover a range of activities including:

- Operations
- Supply
- Maintenance
- Engineering
- Training

An indication of the range of support activities required is given in Fig. 17.5.

17.7 Configuration Management Plan

The configuration of an equipment means the detail of its specification and its key assemblies. In managing deployed assets it will be necessary to keep track of the configuration of the items, as modifications occur, variant models are introduced, or, in the case of fixed plant, new facilities are added and old ones become disused. A viable plan for configuration management should be formed at the logistic support planning stage. More detail of configuration management itself is given in Sect. 11.8.

Operations	Supply	Maintenance	Engineering	Training
Operators	Supply Personnel	Maintenance Personnel	Engineering Personnel	Training Personnel
Operating Facilities	Supply Facilities	Maintenance Facilities	Engineering Facilities	Training Facilities
Operating Support Equipment	Transport, Storage and Handling Equipment	Maintenance Equipment	Engineering Support and Test Equipment	Training Equipment
Operating Documentation	Supply Commodity and Spares Catalogs	Maintenance Manuals	Engineering Drawings and Data	Training Materials
Operations Management	Supply Management	Maintenance Management	Engineering Management	Training Management
Operating Management Information Systems	Supply Management Information Systems	Maintenance Management Information Systems	Engineering Information Systems	Training Information Systems

Fig. 17.5 Through life support systems required

17.8 Through Life Support Contract

Factors to be considered in letting a through life support contract include:

- Maintenance support
- Supply support
- Engineering support
- Labor augmentation for periods of high demand or specific needs
- Cataloging

Performance indicators relating to such a contract include:

- Prime equipment availability
- Rotables availability
- Reliability following repair.

17.9 Logistic Support Example

A logistic support example is shown in Fig. 17.6. This relates to the acquisition of a considerable number of large earth moving machines for a remote site.

Five percent of the acquisition budget was committed for the purchase of spare parts. This was intended to cover the first 3 years of operation.

At the point of introduction into service, supporting documentation was delivered concurrently, along with familiarization and training courses for operators and maintainers.

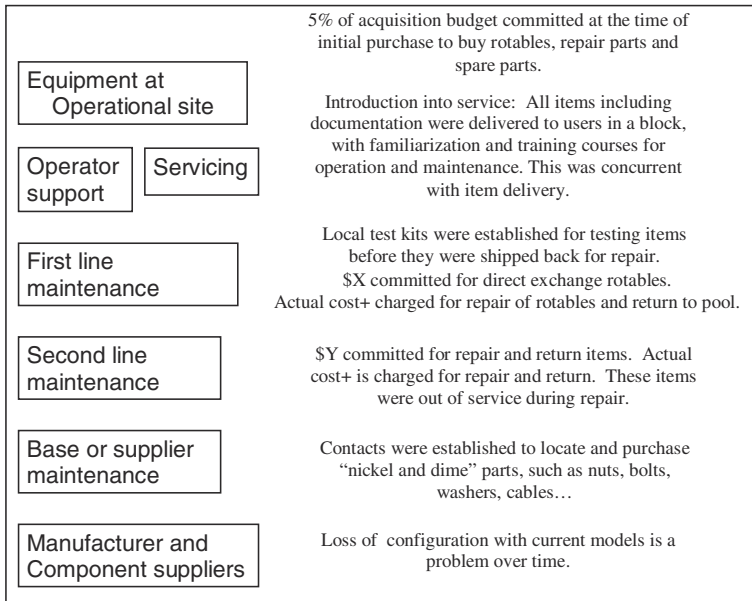

Fig. 17.6 Logistic support example

At first line repair, test kits were supplied to provide a range of tests for items which needed to be checked before possibly being shipped back for deeper repair. Budget (\$X) was set aside for rotables which were to be exchanged and shipped back to either second line or the supplier.

At second line repair, a similar arrangement was made, with allocated budget (\$Y), allowed for repair and return of items requiring repair at the supplier's facilities.

Numerous cheap but essential items (nickel and dime parts) were seen as a problem as it was important not to use inferior substitutes. Contacts were established to obtain these from reputable sources.

Configuration management was put in place, but it was recognized that loss of configuration in relation to current models would be a problem over time. This would ultimately be solved by replacement of the fleet.

17.10 Supplier or Contractor Viewpoint

Suppliers and contractors involved in the original equipment provision are usually involved in subsequent logistic support. There will be a requirement for the supplier to provide user documentation and information relating to equipment operation, including safety issues, and this is often augmented by a performance

warranty. Maintenance recommendations, workshop manuals, and spare parts catalogs are also developed and provided by the original equipment manufacturer (OEM) or supplier.

From the supplier or contractor's viewpoint, the provision of logistic support beyond the basic minimum is an additional business opportunity, although care must be taken to ensure that costs are covered and an adequate profit is generated. The provision of logistic support by a supplier can also be a plus in securing the original sale. However, users must be aware that suppliers can only provide support to the extent that it is good business to do so. It is common for users to underestimate the cost of providing support, and thus to have unrealistic expectations of support provisions. If on-going support is to be provided by a manufacturer, they need to consider the cost of maintaining production processes for original equipment and components to which they are committing, and to identify the people and facilities needed to maintain support, in terms of skill sets, numbers, training requirements, and training facilities.

Services that may be provided on a contract basis include:

- a. consumables provision, transportation, and storage;
- b. spare parts provision and stock holding;
- c. support for introduction into service;
- d. repair, maintenance, and overhaul support;
- e. training of operators and maintainers;
- f. training of operator and maintainer trainers;
- g. technical data management;
- h. configuration management;
- i. support facilities and test equipment;
- j. disposal process.

As a supplier, it is important to adequately cost the provision of such services and to assess the physical and cost requirements over the life cycle of the equipment which is supported. Activity-based costing can be important in this application. Do not try to subsidize the logistic support contract from the initial sale contract. Consideration will need to be given to the provision of the skills required for the tasks to be undertaken, and to being able to retain these skills out into the future. A common approach is to establish separate distributor and support businesses which need to be viable in their own right.

Key elements of logistic support provision are the same in principle as for the user, but the support may extend across a range of users, so the types and numbers of items must be assessed accordingly. Thus we need to consider the following aspects across the range of items supported.

- The types of item for which maintenance is to be supplied;
- The numbers of items of each type;
- The level of utilization;
- Operating environment and any special factors arising from this.

Identify the maintenance level to be covered such as;

- workshop inspection and repairs,
- deeper maintenance,
- overhauls,
- rotables and related repair pools,
- repair/replace policy and related equipment replacement pools.

Plan numbers of trainees for operations, maintenance, and trainers; prepare training facilities; provide an online spares catalog and cost the service provision.

Consider the cost and practicality of maintaining the resources and skill sets necessary to provide the intended support services over the contract period. The equipment supported and the range of technical facilities required in your business will change over time and personnel will retire or move on. Do not under estimate the cost of support provision for aging assets. Consider disposal of consumables, used and unused spares and equipment. Consider the cost of contract preparation, negotiation, and on-going management.

17.11 Cunning at the Castle

Scene: An Ante-Chamber in the Palace

Enter Roderick, an asset manager and Cuthbert, a political strategist.

R: Look here Cuthbert, this plan of King Henry's is crazy. He wants to take the army to France and conquer it!

C: What's wrong with that?

R: The French will knock the stuffing out of our lot, that's what

C: Surely not—what about Agincourt and the gallant English archers?

R: Don't forget the Welsh—but either way the archers are no more. They were disbanded after Formigny

C: Formy—what?

R: Never mind—it's French. It won't feature in English history because we lost. The point is that the French have cannons that outrange our archers by a mile and can crumble a castle like chips. We've got no chance against them until our boys down at the Arsenal develop some new skills

C: So we need a strategy

R: It's more serious than that, Cuthbert, we need to do something. Get thinking

C: *thinks*.....Maybe we could make the French expedition more of a fashion show. The French are cool dudes and if we work it so that Henry goes "all-clinking in gold like a heathen god," to coin a phrase—but just wants to gallop around flashing the Spurs—then they might buy it

R: Good one Cuthbert. The French first team is off in Italy as it happens; its game on at Milan. So we'll go for your plan. Vive le spin

A week later

- C: The French trip is under control, but it's the Scots that I'm worried about. They're getting up a mighty head of steam with King Jimmy and the Bishop telling them they can beat hell out of us and grab England now Henry is over in France. Get your thinking cap on to that one
- R: Nothing that some creative asset management can't handle; we'll send Henry's troops only the old gear, bows and arrows, swords and heavy armor, and keep the newer stuff here
- C: Good, but who's going to run the show against the Scots?
- R: Easy—Queen Katherine. She may not be good at producing sons but she sure can run a war
- C: She can't lead the army though—and don't tell me about Joan of Arc
- R: No, but she's smart enough to put Tommy Norfolk in charge. We'll draft requisitions for the supporting logistics, and bring in plenty of those soccer hooligans from up North

Some months later in a back room of the Palace

- R: Nice one Cuthbert!
- C: Nice one Roderick!

They drink

- R: Henry flashed his Hampton in Flanders and good old Norfolk gave Scotland a flogging at Flodden
- C: Just shows what you can do when political strategy and asset management work together
- R: But methinks we should retire posthaste. Henry is at the gate.

17.12 Exercises

17.12.1 Self-Assessment Questions

1. What is LSA and when is it carried out?
2. What data are required for LSA?
3. What is LORA?
4. What levels of repair are normally considered in LORA?
5. What is ILS?
6. Identify five types of activity where a supplier or contractor might typically offer a logistic support contract

17.12.2 Logistic Support Analysis—Tooth Brush

The Antarctic Corporation (AC) is sending a party of 100 persons to a remote Antarctic site for 1 year.

Carry out a LSA for three toothbrush options:

- Manual
- Electric battery discardable
- Electric battery rechargeable.

17.12.3 Racing Cycle Team

You are the logistic support manager for a cycle racing team. Outline in dot point form the logistic support requirements and plan for the team.

17.12.4 Level of Repair Analysis Exercise

An upstream gas supplier operates a large number of wells at scattered, unmanned sites. There is an automatic radio communication system from the sites to a central control room. The organization needs to decide its “Level of Repair Analysis” policy for the communication system.

Analysis shows the following failure modes:

- Battery flat
- Transmitter failed due to electronic fault
- Broken knobs, leads, and connectors
- Extensive physical damage

What Level of Repair policy do you recommend?

17.13 Exercise Solutions

17.13.1 Self-Assessment Questions Solutions

1. *What is LSA and when is it carried out?*
 - a. Logistic support analysis is the determination of the equipment, people, and facilities required to support a given capability throughout its life. Logistic support analysis is designed to determine the “what, how, and where” of the provision of support resources and services for physical equipment. It is carried out in the decision making phase in which we decide the broad parameters of the provision of logistic support for our equipment.

2. *Identify four items of data that are required for LSA.*

Any four of:

- a. Asset type
- b. Asset quantity
- c. Utilization rate or “rate of effort”
- d. Planned equipment availability
- e. Period of support or overall operation duration
- f. Specific environmental or operational factors
- g. Nature and quantity of equipment to be retired and the effect of this on support requirements.

3. *What is LORA?*

- a. Level of Repair Analysis is concerned with determining where various maintenance activities are to be carried out, so that appropriate staff and facilities can be provided. Level of Repair Analysis is used to determine at what level maintenance will be carried out for each planned activity and for each failure mode.

4. *What levels of repair are normally considered in LORA?*

- a. Operator
- b. Servicing (routine)
- c. First line
- d. Second line (workshop)
- e. Third line (base repair, overhaul, or outsourced).

5. *What is ILS?*

- a. Integrated Logistic Support is a system for ensuring that, once we have decided on our logistic support concept, all aspects necessary to implement it are identified and arranged for.

6. *Identify five types activity where a supplier or contractor might typically offer a logistic support contract.*

Any five of:

- a. consumables provision, transportation, and storage;
- b. spare parts provision and stock holding;
- c. support for introduction into service;
- d. repair, maintenance, and overhaul support;
- e. training of operators and maintainers;
- f. training of operator and maintainer trainers;
- g. technical data management;
- h. configuration management;
- i. support facilities and test equipment;
- j. disposal process.

17.13.2 Logistic Support Analysis—Tooth Brush Solution

The Antarctic Corporation (AC) is sending a party of 100 persons to a remote Antarctic site for 1 year (Fleet size = 100; Mission duration = 1 year; Climatic factor).

Carry out a LSA for two toothbrush options:

- Manual
- Electric

Manual Brush life 3 months estimated. Estimated consumption 400 including initial issue. Contingency allowance 10 %. Asset management policy: Replace on request, notify users if consumption excessive.

ILS Plan Purchase 440 brushes and plastic container for storage.

Electric Components: Batteries \times 2 per brush, battery life 2 months (climate factor); brush body life 12 months; brush head life 3 months; battery case end cap life 12 months. Asset management policy: replace components on request; hold some complete brushes to cover possible losses.

ILS Plan Purchase 120 complete brushes; 1,100 batteries; insulated, waterproof container for batteries; allocate battery storage space in protected area; 10 brush bodies; 330 brush heads; 10 end caps; plastic container for storage. Rechargeable battery model dismissed as impractical for this location. Might also consider, toothpaste, disposal of items.

17.13.3 Cycle Team Logistic Support Exercise Solution

Routine maintenance checks for lubrication, brakes, gears, alignment, geometry, and balance

- Spare bicycles
- Spare parts
- Tools
- Skilled mechanics with strong expertise and sense of commitment
- Transport
- Communication system operation and maintenance
- Health and medical support.

17.13.4 Level of Repair Analysis Exercise

Site inspectors to handle battery changing and replacement of broken knobs, leads, and connectors.

Electronic faults to be handled by installing a replacement transmitter and returning the faulty one to the supplier, to be replaced by a reconditioned transmitter to the store.

Items with extensive physical damage to be replaced and the damaged item disposed of thoughtfully.

Chapter 18

Asset Basic Care

Good housekeeping

Abstract To describe the features and organizational structures used in care of assets from good housekeeping through to basic maintenance. To consider performance monitoring and recording and continuous improvement techniques. *Outcomes* After reading this chapter you will understand the importance of good housekeeping and basic maintenance and how to organize the workplace so that these are well managed. You will be aware of the continuous improvement cycle and techniques associated with it.

18.1 Introduction

An essential requirement of successful asset management is taking care of assets. This involves activities at several levels, ranging from cleanliness and good housekeeping by the user or operator, to first-line maintenance activities such as servicing, lubrication, and adjustment, to second-line maintenance involving repairs and assembly changes, and on to deeper maintenance or overhaul. In addition, there are many technical factors in maintenance, including condition monitoring.

Determining the right level of maintenance activity and hence of expenditure is not an easy task. The role of asset managers is to be aware of available techniques both in terms of management and technology and to apply them appropriately to the benefit of the business. It may be tempting to senior managers to demand more production or to cut maintenance budgets as a response to problems, but such actions quickly become counterproductive if the basic care and maintenance of assets is neglected.

18.2 Total Productive Maintenance or Asset Basic Care

At first-line level, in a manufacturing context, the process of caring for assets is referred to as *Total Productive Maintenance* (TPM). A more general term is *Asset Basic Care*. Asset Basic Care/TPM involves workplace employees, such as operators and first-line maintenance staff in achieving a high standard of care of assets as an integral part of their normal work. The main focus in Asset Basic Care is on the *people* and how they do their work. Asset Basic Care/TPM is *non-heroic maintenance*. This means doing the routine things well, rather than an emphasis on heroic repair jobs. The major elements include:

- Cleanliness and good housekeeping;
- Routine inspection, lubrication, and adjustment;
- Focus on machine knowledge, machine performance, quality of output and elimination of losses;
- A sense of ownership by operators and first-line maintainers.

The concepts in Asset Basic Care/TPM are summarized in Fig. 18.1.

18.2.1 Workplace Tidiness and Organization

The first essential of asset basic care is a tidy workplace. Some areas have never been tidied up since the industrial revolution. Remove unused or inessential items, especially:

- old or imperfect product
- surplus materials,
- obsolete or unnecessary tools,
- obsolete fixtures,
- obsolete or inessential documents, and
- horse-drawn wagons unless it is a theme park.

Having tidied up, get organized. For each workplace list all required:

- tools and instruments,
- implements,
- accessories, and
- consumables.

Determine a place for all essential items and provide:

- shelves,
- containers,
- holders, and
- labeling.

Fig. 18.1 Asset basic care or total productive maintenance

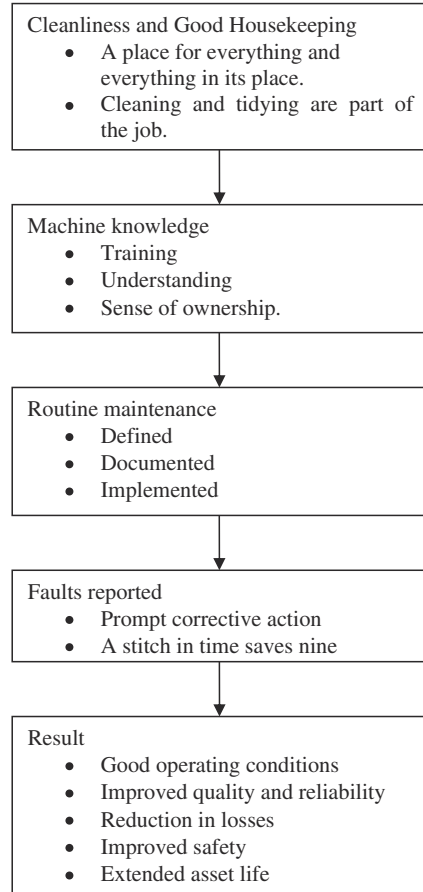

Use simple indicators, e.g., marks on the floor, colored shelves to show placement of essential items. Use these facilities and keep items visible.

18.2.2 Maintain Standards

- Take countermeasures against dirt and dust.
- Determine how everything is to be kept clean.
- Provide equipment such as brushes, cloths, vacuum cleaners, and dish washers.
- Design out systematic uncleanliness, using shields, covers, waste disposal methods, etc.
- Make cleaning and tidying up a standard part of every job.

Set cleaning and tidying standards and routines.

- Assign responsibilities.
- Rotate tasks among operators and allow them to agree on who does what.
- Specify cleaning time, e.g., 5 min at end of each shift and half hour per week, plus if idle.
- Assign responsibilities for all aspects of supply, storage, and disposal of workplace items.

18.2.3 Training

Create the training material for:

- correct operating conditions and procedures
- machine knowledge
- basic maintenance procedures
- fault reporting procedures
- knowledge of existing types of faults or losses.

This is done by supervisors and experienced maintenance personnel, initially for a pilot area, later extended to all operations. Training facilities are needed, e.g., training room next to the shop floor, white board, projector, and training materials.

18.2.4 Machine Knowledge

Develop and display machine information on notice boards beside the machines.

- Name of machine
- What it is intended to do
- How it works—without going into unnecessary technical detail; use simple flow chart
- Written, step-by-step details of all necessary procedures, including operating conditions, e.g., temperature, pressure, vibration, and alignment checks.
- Troubleshooting guide.

The creation and maintenance of this material is a worthwhile learning task for young graduates.

18.3 Basic Maintenance

Asset performance and sustainment are greatly improved if equipment is kept in good condition. To achieve this, basic maintenance must be carried out on a regular basis. Besides cleanliness, this includes lubrication, adjustment of things that

are intended to be adjusted, and tightening or replacement of loose or missing nuts and bolts. In Asset Basic Care/TPM, we organize basic maintenance with the aid of the following steps:

- Create basic maintenance procedures, standards, and routines.
- Specify maintenance and inspection intervals and times.
- Identify and document lubrication points, adjustment points, checks for nut or bolt tightness and anything else that the operators or first-line maintainers can usefully know.
- Color code lubrication points and adjustment points by interval, e.g., daily, weekly, and monthly checks.
- Identify abnormal conditions in specific terms, e.g., pressure or temperature gage readings, measurements, flow rates.
- Specify action to be taken (e.g., call the mechanic) if conditions are abnormal.
- Define basic inspection procedures, this can include checks for:
 - Loose, missing, broken bolts fasteners, clamps, etc.
 - Frame and structural cracks, weld failures, etc.
 - Corrosion
 - Wear
 - Vibration
 - Oil/fuel/coolant/air leaks,
 - Accident damage, e.g., bent sheet metal, broken items, etc.
- Specify action to be taken from inspection results, including immediate corrective action, and the raising of work requests for activities which can be deferred. Define how to report conditions which are outside the operator’s scope of activity.
- Train workforce personnel in basic maintenance, diagnostics, and reporting.
- Assign responsibilities.
- Rotate tasks among operators and allow them to agree on who does what.

18.3.1 Assign Housekeeping and Basic Maintenance Tasks

Appraise tasks and assign them as you think best, with input from those involved. The essential thing is that all tasks are assigned, Fig. 18.2 shows examples of possible assignments.

Fig. 18.2 Assignment of basic care tasks

Task Type	Assign to
Cleaning/housekeeping	Cleaner or operator
Operating	Operator
Servicing	Operator or lubricator
Minor set up	Operator or technician
Minor repair	Operator or technician
Skilled maintenance	Technician

18.3.2 Routine Maintenance by Technicians

More technical maintenance activities will normally be assigned to technicians. Particular attention must be paid to the carrying out of maintenance activities which are required by law or by good practice, such a boiler or pressure vessel inspections.

18.3.3 Accredited Workers

After training, test the competency of workers on machine knowledge, operation, and basic maintenance. Recognize their achievements by accrediting them to operate the relevant machines; give them a certificate. This may involve upgrading and higher pay, but an overall payoff can be expected.

The workers closest to the equipment, operators, and first-line maintenance technicians, have the greatest level of involvement and the greatest degree of equipment knowledge at the user level. This knowledge can be leveraged by empowering the workers to take a wide range of actions in support of production operation and maintenance. In addition to good housekeeping and basic maintenance, these actions can include the replenishment of work place equipment, contact with second-line maintenance, participation in quality and condition-monitoring activities and performance recording and analysis. Participation in continuous improvement activities and root cause failure analysis activities should also be encouraged.

18.4 Performance Recording

Collect and display simple statistics, e.g.,

- Machine down time by weeks (time lost to operators).
- Machine lost time by weeks (time machine available but not effectively used by operators).
- Quality losses by weeks, numbers of subquality product.
- Unplanned maintenance activity by months, showing type of breakdown/repair.
- Time spent on (particular) setups.
- Causes of losses sequenced by frequency of occurrence.
- Causes of losses sequenced by cost significance.
- Trend over time to show improvements and opportunities.

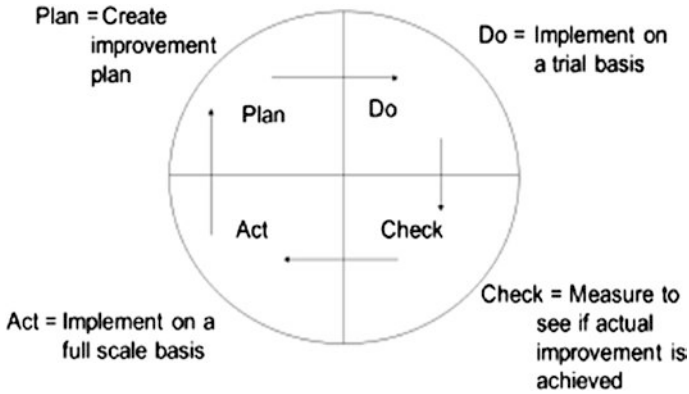

Fig. 18.3 Continuous improvement cycle

18.5 Continuous Improvement¹

Continuous Improvement is an ongoing process whereby we try to improve products, services, or processes, in incremental steps. This approach is in contrast to, though not excluding, occasional breakthroughs. The high standard of housekeeping and maintenance, and the recording of performance data and identification of losses and their causes, as promoted by TPM, provide a basis for the improvement of performance, of quality and of reliability. In the production context, the potential for and methods of improvement are well documented in works on TPM and Total Quality Control, such as those of Hartmann, Ishikawa, and Suzuki listed in the references section. These advantages should also be carried over to nonmanufacturing asset management situations. Operations information regarding losses and data from inspections and routine maintenance form an important source of knowledge regarding equipment condition. This then forms a basis for improvements in performance and reliability of equipment and as a possible pointer toward equipment replacement. In forming a budget, we should allow funding to encourage developments which can support continuous improvement and which can emerge from any level of the business.

18.5.1 Deming Wheel

The cycle of continuous improvement is illustrated by the “Deming wheel” shown in Fig. 18.3 Continuous Improvement Cycle. The wheel involves four steps known

¹ ISO 55001 Clause 10.3 Continual improvement: “The organization shall continually improve...”.

Fig. 18.4 Fishbone diagram (Ishikawa)

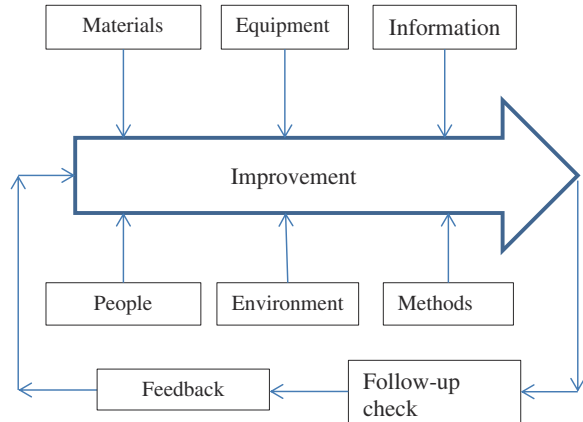

as Plan, Do, Check, and Act which are shown and explained in Fig. 18.3. Care must be taken to ensure that changes are approved by technically qualified and authorized persons before being implemented.

18.5.2 Fish Bone Diagram (Ishikawa²)

Another aid to continuous improvement is the systematic consideration of the factors involved in a process. The “fishbone” diagram, of which a simplified version is shown in Fig. 18.4, acts as a guide in relation to the various types of factors that may be involved in an industrial process. Points to be considered are:

- Materials: Suitability, Wear, Corrosion, and Fatigue
- Equipment: Suitability, Capacity, Condition, Instrumentation, and Calibration
- Information: Documentation, Access, and Up-to-date?
- People: Knowledge, Training, Skills, Teamwork, Recognition, and Feedback
- Environment: Temperature, Humidity, Lighting, and Cleanliness
- Methods: Defined, Appropriate, Documented, and Followed?

Care must be taken to ensure that changes are approved by technically qualified and authorized persons before being implemented.

² Ishikawa, Kaoru, “Guide to Quality Control”, Asian Productivity Organization.

Fig. 18.5 Workplace problem report

WORKPLACE PROBLEM REPORT	
To: Improvement Co-ordinator	
From:	
Date:	Reference No.:
Details of Problem:	
Suggested Solution (If Any):	

18.6 Improvement Coordinator³

An improvement coordinator is a person who acts as a focus for improvement suggestions, receiving proposals, and assessing and progressing them. Organizations can benefit from having an improvement coordinator (not usually a full time commitment but something extra for an already busy person!) and a standard form called a Workplace Problem Report. Anyone can originate a Workplace Problem Report and send it to the Improvement Coordinator. An email message is an alternative to the printed form. An example of a form is in Fig. 18.5.

The Improvement Coordinator maintains a record of all Workplace Problem Reports received, and acts as follows:

- Check problem and possible solutions with originator and relevant managers, technical personnel, suppliers, etc.
- Initiate and monitor appropriate actions if any.
- Report on results. This should include cases where no action is taken, with reasons.

³ ISO 55001 Clause 10.1 Non-conformity and corrective action: “When a nonconformity or incident occurs...the organization shall ... react ... take action ... review ... make changes if necessary...”.

18.7 Asset Basic Care/TPM—Management Support

Maintenance must be recognized as important by senior managers and all employees—the Plant Manager needs to commit to this. This recognition includes ensuring that routine maintenance is carried out and is not neglected due to pressure from operations staff or lack of maintenance budget.

Management should assign specific equipment to specific operators or small groups, giving them responsibility and empowerment. As an example, it is a practice in the United States Air Force to assign management of each aircraft to an individual. This individual follows the aircraft when it goes for servicing or repair and ensures its security, integrity, and priority are maintained.

Have a clear chain of technical expertise and use it. Do not remove all expertise from a site. Have a fully functioning work request, job scoping, job planning, work order, job scheduling, and progress/result reporting system.

18.7.1 Asset Basic Care/TPM Summary

- Cleaning and housekeeping.
- A place for everything and everything in its place.
- Visible, documented procedures.
- Operator and first-line technician training in...
- Lubrication skills.
- Diagnostic skills.
- Minor adjustments.
- Minor setup changes.
- Routine maintenance (technicians).
- Minor repairs (technicians).
- Operator/maintainer certification.
- Sense of ownership.
- Continuous improvement.
- Create routine maintenance schedules on a calendar.
- Balance the workload.
- Publish the schedule, working with production to ensure agreed program.
- Stick to the routine!
- Work request and work management systems to be used for all nonroutine work.

18.7.2 Asset Basic Care/TPM Benefits

- More production through reduction in losses
- Improved product quality
- Improved working conditions

- Improved safety
- Overtime reduction
- Reduced absenteeism
- Environmental and legislative compliance
- Extended asset life.

18.8 A Shock from Japan

“What did you do after the war, Pop?” Jock asked, on one of his weekly visits to his grandad.

“I had a few different jobs in the big car companies in and around Birmingham,” said Pop. “The most interesting was later when all those Japanese production methods hit us. I didn’t know what they were talking about at first. There was Just In Time and Kanbans and TPM. Our factory was near the original site where James Watt and Matthew Boulton started building their steam engines that kicked off the industrial revolution around 1789. The trouble was that no one had tidied up for 200 years. There was an amazing amount of accumulated dirt, dust, swarf, congealed oil and broken or reject castings in our machine shop.

“I’d retired from production management by then and was assigned to ‘continuous improvement’. I tried to change things in the machine shop but it was too hard. Luckily we had an assembly area where most of the workers were women. They quickly picked up on the idea of everything being clean and tidy and were soon ahead of me, bringing in pot plants and feather dusters and stuff. Once the other departments saw how nice and clean their assembly area was they got the message. We took four big skips of rubbish out of the machine shop in 1 day.”

“After that I got an assignment in a car lamp factory. I remember my first meeting on the site. The new managing director was on a mission to boost production and told the managers to get production up to one million lamps per month, ‘or else’.”

“About a month later I came out on to the landing beside the offices which looked over the production area. The partly finished lamps were moved around in metal cages. The production area was solid with cages and the crane driver had a cage on the crane and was looking for somewhere to put it down—but there was no space left. Everything was jam-packed and production was at a standstill!”

“Luckily this crisis gave me an opportunity. For one thing, it was obvious that setting a goal of producing one million lamps a month was dumb. The factory had met the target by churning out lamps which were easy to make and disregarded everything else, including the customers.”

“I got them to switch to a Kanban system where work centers had marked spaces between them for holding inter-process stock. Once their ‘output’ space was filled, they stopped producing. The old hands said that they would never achieve quota this way, but in fact sales increased. I was surprised myself. It didn’t seem to make sense, but I found that, although the throughput of lamps

at particular work centers was less, this was more than offset by less rejects and less re-work. Also, the kanbans ensured that we were making the lamps that the customers wanted.”

“That’s great,” said Jock, “but we don’t seem to have taken much of it on board in maintenance or in the mining and mineral processing industries that I’ve seen. Maintenance workshops always seem to look like your description of 20 years of rubbish,—stockpiles of ore or tailings seem to build up all over the place. I may be exaggerating a bit, but I think that there’s a lot we can learn from the ‘lean’ techniques that you manufacturing blokes were using years ago.”

18.9 Self-Assessment Exercise

Note: In this exercise the term Asset Basic Care is used to include the concept also known as TPM.

1. What is meant by Asset Basic Care?
2. Identify four features of Asset Basic Care.
3. Identify six activities involved in Basic Maintenance.
4. What is meant by Continuous Improvement?
5. What are the four stages of continuous improvement which appear on the Deming wheel?
6. What is the role of an Improvement Coordinator?

18.10 Self-Assessment Exercise Solutions

1. *What is meant by Asset Basic Care?*
Asset Basic Care involves workplace employees, such as operators and first-line maintenance staff in achieving a high standard of care of assets as an integral part of their normal work.
2. *Identify four features of Asset Basic Care.*
Cleanliness and good housekeeping;
Routine inspection, lubrication, and adjustment;
Focus on machine knowledge, machine performance, quality of output and elimination of losses;
A sense of ownership by operators and first-line maintainers.
3. *Identify six activities involved in Basic Maintenance.*
Any of the following:
 - a. Create basic maintenance procedures, standards, and routines.
 - b. Specify maintenance and inspection intervals and times.

- c. Identify and document lubrication points, adjustment points, checks for nut or bolt tightness, and anything else that the operators or first-line maintainers can usefully know about.
 - d. Color code lubrication points and adjustment points by interval, e.g., daily, weekly, and monthly checks.
 - e. Identify abnormal conditions in specific terms, e.g., pressure or temperature gage readings, measurements, flow rates.
 - f. Specify action to be taken (e.g., call the mechanic) if conditions are abnormal.
 - g. Define basic inspection procedures this can include:
 - i. Loose, missing, broken bolts fasteners, clamps, etc. Frame and structural cracks, weld failures, etc.
 - ii. Oil/fuel/coolant/air leaks,
 - iii. Accident damage, e.g., bent sheet metal, broken items, etc.
 - h. Specify action to be taken from inspection results, including immediate corrective action, and the raising of work requests for activities which can be deferred. Define how to report conditions which are outside the operator's scope of activity.
 - i. Train workforce personnel in basic maintenance, diagnostics, and reporting.
 - j. Assign responsibilities.
 - k. Rotate tasks among operators and allow them to agree on who does what.
4. *What is meant by Continuous Improvement?*
Continuous Improvement is an ongoing process whereby we try to improve products, services, or processes, in incremental steps.
5. *What are the four stages of continuous improvement which appear on the Deming wheel?*
- a. Plan
 - b. Do
 - c. Check
 - d. Act
6. *What is the role of an Improvement Coordinator?*

An improvement coordinator is a person who acts as a focus for improvement suggestions, receiving proposals and assessing and progressing them.

Chapter 19

Maintenance Organization and Budget

Mankind's greatest invention is not the wheel but the bearing.
—Will Scott, Professor of Tribology,
Queensland University of Technology

Abstract The aim of this chapter is to describe the features and organizational structure used in asset maintenance and to show how the maintenance budget can be created and managed. *Outcomes* After reading this chapter you will be aware of the main features of the maintenance function including maintenance technical services, workflow management, and budgeting.

19.1 Maintenance Aim

The aim of maintenance is to deliver availability of machines and equipment to production or service departments, within the envelope provided by underlying machine condition and the available resources. Maintenance cannot convert a 10-year-old item into a new item, but it can sustain it in, or restore it to, a working condition consistent with its age, provided that this is technically and resource feasible.

19.2 Maintenance Organization

Logistic Support Analysis and Level of Repair Analysis as described in Chap. 17, when aggregated across the asset portfolio, provide the basis for determining the size and structure of the maintenance organization as a whole. In the case of a substantial in-house maintenance organization, the structure will be as illustrated in Fig. 19.1.

Further detail of the maintenance services function is indicated in Fig. 19.2.

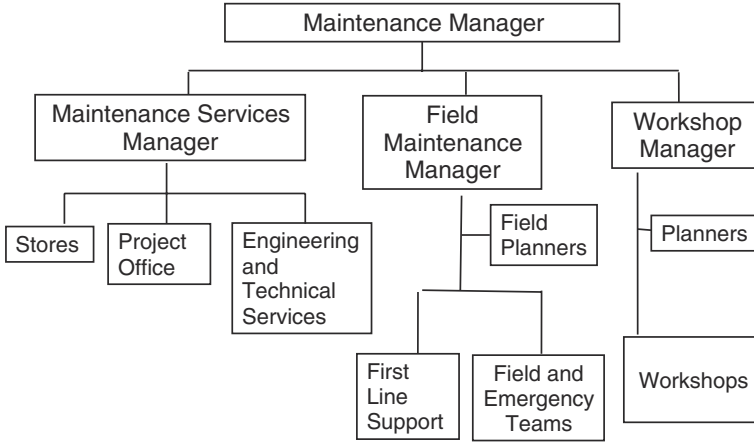
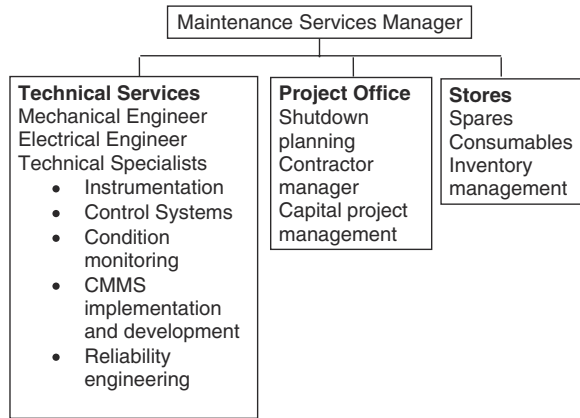

Fig. 19.1 Maintenance organization

Fig. 19.2 Maintenance services



19.2.1 Maintenance Layout

A typical physical layout of a maintenance organization is shown schematically in Fig. 19.3. At first line, this shows some maintenance personnel assigned to production areas A and B and some shown as supporting all areas. The split will depend on whether the production locations are widely separated, or have similar or different technology. Unless there are reasons to the contrary, it is advisable to have most of the maintenance support placed centrally to support all areas as this provides the most efficient use of the resources. Good planning, scheduling, and communications are important contributors to the efficiency of maintenance.

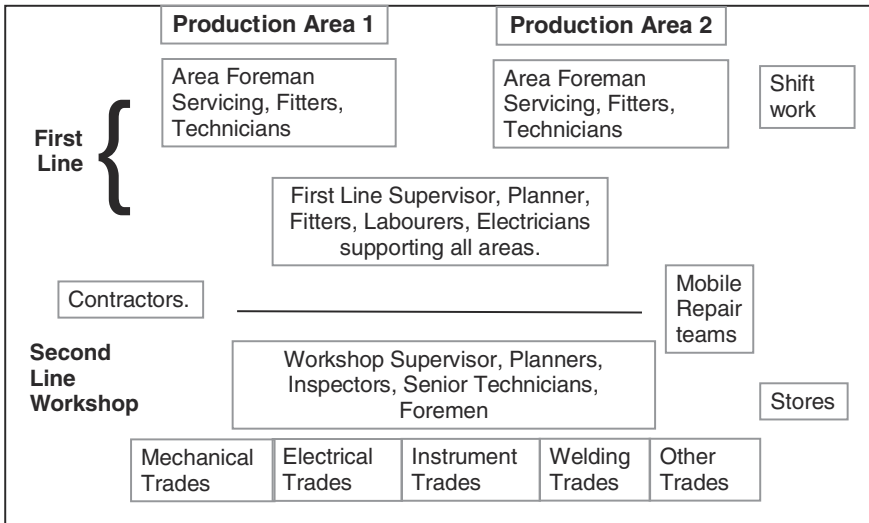

Fig. 19.3 Maintenance layout

19.3 Types of Maintenance Activity

A number of terms are used to describe maintenance activities and are summarized here. The categories are not necessarily mutually exclusive and some overlap may occur.

Routine Work carried out on a regular basis. Includes cleaning, lubrication, inspection, servicing, condition monitoring.

Emergency Action that must be carried out promptly in response to an urgent situation, may or may not involve actual breakdown.

Deferred Corrective work which can be carried out at a convenient time, in contrast to “emergency.”

Preventive Maintenance Maintenance aimed at preventing failures. Lubrication, servicing, component replacement on the basis of age or service time, such as an oil change at 10,000 km, or aero-engine deeper maintenance after a prescribed number of flying hours.

Predictive Maintenance Maintenance aimed at predicting potential failures and taking action to avoid in-service failure. Condition monitoring.

Corrective Maintenance Maintenance to correct known faults. May be Emergency or Deferred. Covers all activities other than routine. Includes activity carried out following conditions identified by reporting, inspection, condition monitoring, or breakdown

Breakdown Failure of an item or system occurs

Nonbreakdown Failure of an item or system does not occur, but action is needed

Scheduled Maintenance Maintenance which is part of a planned schedule. Can include routine maintenance, deferred corrective maintenance and shutdowns. Distinct from emergency maintenance.

Proactive Maintenance Root cause analysis and improvement activities.

Irregular Cyclic Maintenance is maintenance activity which can be expected to recur, though not in a strictly scheduled way. These activities may be triggered by normal observation or by condition monitoring.

Examples are the replacement of:

- tires
- engines
- batteries
- exhaust systems

Maintenance budgeting should allow for these activities, which will be ongoing and can produce significant but irregular costs.

19.3.1 Additional Related Tasks

It is common to find that the resources of maintenance are also drawn on for related tasks such as;

- Rebuilds
- Turnarounds
- Modifications
- Installation of new equipment
- Investigations
- Special functions or occasions

It is advisable to schedule all these activities in the same resource planning schedule in the Asset Management Information System or CMMS. This will provide for a balanced assessment of workloads and priorities.

19.4 Maintenance Work Management¹

The system must provide for and readily maintain:

- work requests;
- work order creation;

¹ D. Nyman and J. Levitt, "Maintenance Planning, Scheduling and Coordination," Industrial Press Inc.

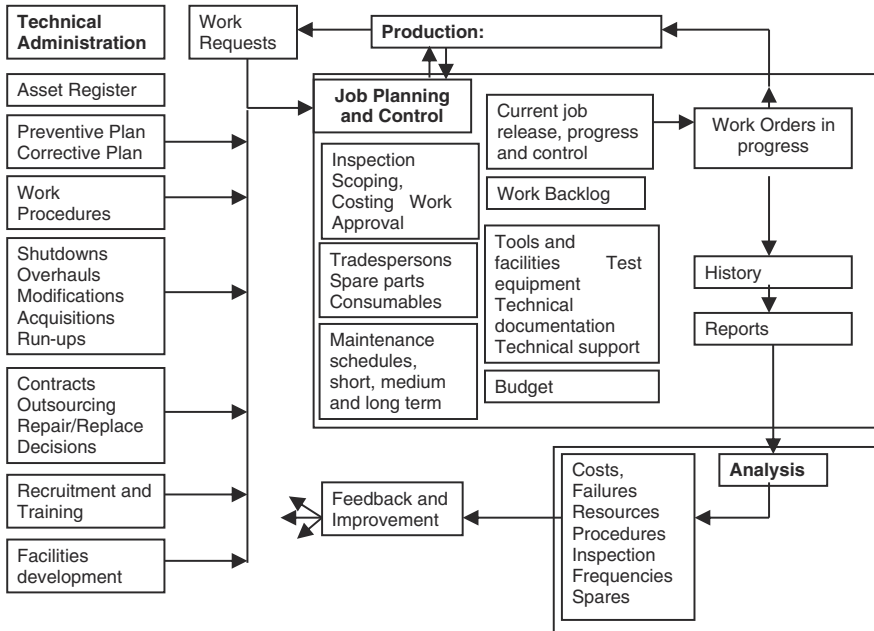

Fig. 19.4 Data flows in the maintenance management application

- list of current tasks;
- up-to-date status knowledge of current tasks;
- roster of resources—who is on duty when;
- schedule of assigned resources—who is doing what now and in the immediate future; and
- a rapid, secure, reliable, simple message passing system, typically based around work orders.

Figure 19.4 shows the data flows which are routinely handled in a maintenance management application of an asset management information system. The asset management system as a whole will also incorporate inventory management, costing, and budgetary management.

19.4.1 Inspection and Scoping

The first step in a maintenance task is for the job to be inspected and the scope of the work to be done to be defined. This leads into the next step which is job planning.

19.4.2 Planning and Costing

Planning is the process of identifying all the resources required to carry out a maintenance task. This includes:

- Trades and technical personnel to perform the task
- Materials and spare parts requirements
- Special tools and equipment required
- Support service requirements such as scaffolding or hire equipment
- Documentation, drawings, technical information required.

The output from the planning process is a Work Order containing all the above details and supporting documentation combined together to form a Work Pack for the task. At this stage the job is costed and approved as necessary.

19.4.3 Scheduling

The maintenance schedule defines when maintenance work will be done. Work will be included in the schedule on the basis of priority. Work will not be included in the schedule until it has been adequately specified by the maintenance planner.

Maintenance work schedules are normally produced weekly and confirmed prior to the start of the schedule commencement date. Except in the cases of an immediate priority (breakdown), the contents of schedules will only be changed by agreement between the relevant operations and the maintenance managers.

19.4.4 Maintenance Control

Maintenance and engineering related work is documented on work orders. All relevant work should be managed on the one work order system. Work Orders provide a basis for:

- Identification and tracking of jobs
- Work authorization and approval
- Work planning and assignment of job responsibility and resource utilization.
- Assignment and tracking of spare parts and materials
- Collection of equipment history and failure data for analysis.

19.4.5 Personnel Roles

Figure 19.5 shows the roles of personnel in the management of maintenance work.

Create Work Request	Anyone
Approve Work Request	Operations supervisor
Scope Work and Create Work Order	Inspector, Planner
Approve Work Order	Maintenance supervisor
Release Work Order when resources available	Planner
Schedule Work	Scheduler
Do work and provide feedback	Maintenance crew
Close Work Order	Planner

Fig. 19.5 Work management activities and typical roles

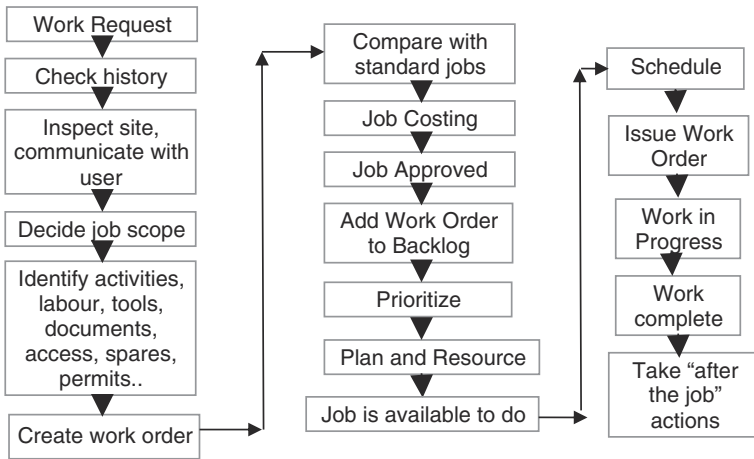

Fig. 19.6 Job scoping, planning, scheduling, controlling

19.4.6 Planning and Control Process

Figure 19.6 shows the sequence of events in the maintenance job planning and control process. In addition to the events shown, allowance must be made for *emergent work*, that is, work discovered as a job progresses.

Job Planner's Check List	
Before the Job	During the Job
<p>What</p> <ul style="list-style-type: none"> <input type="checkbox"/> Is there a Work Order <input type="checkbox"/> Is there enough information <input type="checkbox"/> Inspect site <input type="checkbox"/> Check equipment history <input type="checkbox"/> Is it a symptom of a bigger problem <input type="checkbox"/> Is there related work from the backlog <input type="checkbox"/> Is there an existing job plan <input type="checkbox"/> Establish scope of job <input type="checkbox"/> List sequence of activities <input type="checkbox"/> Is a follow-up job needed <p>Who</p> <ul style="list-style-type: none"> <input type="checkbox"/> Which trades are required <input type="checkbox"/> What hours per trade <input type="checkbox"/> Are special skills required <input type="checkbox"/> Relate to existing commitments <input type="checkbox"/> Identify sequence of activities <input type="checkbox"/> Is contractor work required <p>Spares, Materials</p> <ul style="list-style-type: none"> <input type="checkbox"/> What spare parts are needed <input type="checkbox"/> What materials/consumables needed <input type="checkbox"/> What is spares materials availability <input type="checkbox"/> Are rotables required <input type="checkbox"/> Is a kit required and checked <input type="checkbox"/> Is cannibalisation required <input type="checkbox"/> How will items get to site <p>Tools</p> <ul style="list-style-type: none"> <input type="checkbox"/> What special tools are required <input type="checkbox"/> What test gear is required 	<p>Access</p> <ul style="list-style-type: none"> <input type="checkbox"/> Communicate with production <input type="checkbox"/> Must machinery be stopped <input type="checkbox"/> Must the site be cleaned/cleared <input type="checkbox"/> How will persons and item get to site <input type="checkbox"/> Is space a problem <p>Documents</p> <ul style="list-style-type: none"> <input type="checkbox"/> What procedures are required <input type="checkbox"/> What drawings are required <input type="checkbox"/> What other documentation is required <p>Services</p> <ul style="list-style-type: none"> <input type="checkbox"/> Power and lighting requirements <input type="checkbox"/> Compressed air <input type="checkbox"/> Communications equipment <input type="checkbox"/> Cranes and lifting gear <input type="checkbox"/> Is scaffolding required <input type="checkbox"/> Workshop facilities <input type="checkbox"/> Transport <p>Safety</p> <ul style="list-style-type: none"> <input type="checkbox"/> What hazards are there; mechanical, electrical, chemical, biological <input type="checkbox"/> What hazard avoidance is needed <input type="checkbox"/> Are permits required, (e.g. hot work, confined space, elevated work, ground opening) <input type="checkbox"/> Are there statutory requirements <input type="checkbox"/> Are isolations required <input type="checkbox"/> Are tags required <input type="checkbox"/> Are emergency facilities needed
	<p>Proceed with all necessary work</p> <ul style="list-style-type: none"> <input type="checkbox"/> Report progress <input type="checkbox"/> Is re-scoping or follow-up work needed <input type="checkbox"/> Obtain progress related decisions <input type="checkbox"/> Report effect on other work <input type="checkbox"/> Communicate with production <input type="checkbox"/> Communicate with others e.g. stores, contractors, suppliers, engineering <input type="checkbox"/> Carry out tests and checks needed, operational, performance, alignment, balance, sealing^{60,66} <p>After the Job</p> <ul style="list-style-type: none"> <input type="checkbox"/> Tidy up <input type="checkbox"/> Hand over to production <input type="checkbox"/> Enter work in computer system <input type="checkbox"/> Close job off <input type="checkbox"/> Return unused spares/materials <input type="checkbox"/> Return tools etc. <input type="checkbox"/> Rotables - ensure repair in hand <input type="checkbox"/> Debriefing session <input type="checkbox"/> Update procedures, (include safety) <input type="checkbox"/> Update drawings <input type="checkbox"/> Update configuration documents <input type="checkbox"/> Initiate any follow up work required

Fig. 19.7 Job planners checklist

19.4.7 Planners Checklist

Figure 19.7 provides a checklist for job planners in relation to the creation and progressing of maintenance jobs (with acknowledgments to John de Haas).

19.4.8 Job Priorities Scheme

Figure 19.8 shows a scheme of job priorities.

19.4.9 Weekly Scheduling Process

Figure 19.9 shows the sequence of activities in creating and managing the schedule of maintenance work from week to week.

1. Emergency - immediate	Immediate safety hazard Serious impact on production or service Actual or potential serious plant damage Infringes environmental safeguards
2. Current – within 1 week	Potential to become priority 1 if unattended Reduces standby or backup capability Note: Routine maintenance slots in here.
3. Short term – within 1 month	Desirable modifications to benefit personnel or efficiency Likely deterioration in short term if not performed
4. Medium term – within 2 months	Likely deterioration in medium term if not performed
5. Long Term	Seen as advantageous but not essential in short or medium term.

Fig. 19.8 Job priorities scheme

1. Each week the scheduler produces a schedule of work for the following week.
2. Assuming a week of Monday to Sunday, the schedule is produced on Thursday for the following week.
3. There is daily feedback on the schedule. The scheduler provides updates where needed but schedule stability is regarded as of considerable importance.
4. Some work will usually carry over into the next week.
5. The scheduler takes jobs on a basis of priority, drawing primarily from the available-to-do work in the backlog, and adds them into the schedule, until the available resources are committed.

Fig. 19.9 Weekly scheduling process

19.5 Maintenance Budgeting

19.5.1 The Business Plan

The starting point for maintenance budgeting is the business plan. In a mining operation, for example, the business plan will provide a production plan at each mine, and will give a planned number of tonnes of material to be moved in the year, in various categories such as overburden, ore, and processed material of various types. The plan will often be structurally similar to that for the previous year, but the quantities will vary to a greater or lesser degree. An increase or decrease in the mined and processed quantities will affect the maintenance workload, as will variations in such factors as the distance from the ore body to the processing units. In addition to the basic processes there will be many subsidiary activities which must be taken into account.

The fact that changes from year to year are often marginal is both a blessing and a curse. It is a blessing in that the maintenance workload, and hence the maintenance budget may then be derived by marginal changes, but it is a curse in that a considerable drift in the maintenance resources from those actually required can occur over time. Indeed, it is not uncommon to find that quite drastic changes in the maintenance workload by quantity and type have not been responded to in the maintenance budgeting process.

19.5.2 Zero-Based Budgeting

Zero-based budgeting is calculating a budget from first principles based on the current requirements of the business. In this approach, every item of the budget must be justified from first principles. During a pure zero-based budgeting process, no reference is made to the previous level of expenditure. This is in contrast to incremental budgeting which focusses on variances from past years, based on the assumption that the baseline is approximately correct.

19.5.2.1 Reasons for Zero-Based Budgeting

The reason for zero-based budgeting is that incremental budgeting can fail to keep up with changes in the business or the technology. Such changes may affect the workload by trades, by location and by operational requirements, and also create a need for capital equipment changes.

19.5.2.2 Limitations of Zero-Based Budgeting

Zero-based budgeting would seem to be the most logical way to form a budget. However, zero-based budgeting relies on the assumption that the needs of the business can be accurately assessed from first principles at every stage of the budgeting process. The end result may be that an essential item or service is missed or grossly over or underrepresented.

On balance we should always be alert to the need for a zero-based approach to any item, but should be sure to fully evaluate the possible reasons for the previous budget allocations and also take note of the “maintenance iceberg” visible later in this chapter.

19.5.3 Creating the Budget

The basic logic is summarized in Fig. 19.10.

The first step in Fig. 19.10, the production plan by type and quantity, must be provided by operations as part of the overall operational planning process. In Step 2 of Fig. 19.10, the maintenance budgeter analyzes the production plan to determine the corresponding machine requirements. The service level required by the business plan is a factor in determining the machine requirements. For example, in a railway operation, the timetabling plan will determine the required numbers of trains and this in turn will determine the availability level needed from the train fleet.

In Step 3 of Fig. 19.10 we determine the maintenance workload in order to meet the planned machine availability. This should be done as part of the total planning process. The success of the production plan will be dependent

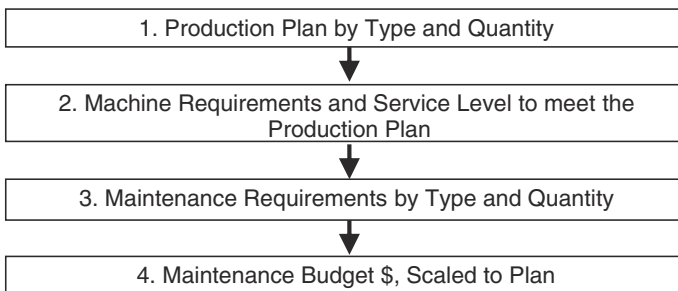

Fig. 19.10 Basic logic of the maintenance budget

on the ability of maintenance to service it, and the implications of the plan for maintenance physical and financial resources must be taken into account. The process continues over the range of maintainable assets, summarized to major blocks, with considerations of criticality, service level and required availability. Finally, the maintenance plan is used as a basis for creating the maintenance budget.

19.5.4 Using the History

Useful reference points at this stage are the operational loss data and work order data from the previous year. By analyzing operational loss data as an indicator of shortfalls in the past (such as canceled trains), and the work order data by trade, equipment, and location we can establish maintenance load per machine hour and in total. To be able to use the history data in this way, we must have been tough about requiring all operational performance data and maintenance jobs and hours to be reported. The analysis may make use of Pareto charts and pie charts to highlight where and how operational losses occurred and where maintenance money has been spent. This can turn up surprises, as the work done in particular areas may well be considerably out of kilter with expectations and with allocated resources. The operational loss data is useful as an indicator of achieved availability, and as an aid to focusing on loss reduction, to help justify the budget to operations and to senior management.

19.5.5 Walking Around

In addition to data analysis it is important to see the situation on the ground, particularly in regard to backlogs and equipment condition. Local management should be able to pinpoint areas of required capacity or surplus capacity on the basis of direct experience. Of course, local management will wish to have a generous allowance of resources and this must be aimed off for.

19.5.6 Backlog

Maintenance backlog is work which is either overdue or which is required to be done but has not yet been started. It is normal to have a moderate amount of backlog, particularly in regard to deferred corrective work which can be scheduled at a convenient time or on an opportunistic basis. However, excessive backlog is a danger sign in regard to the maintenance function. The budgeting process should allow for catching up with excessive backlog.

19.5.7 Sources of Maintenance Work

In developing the maintenance requirements consider the sources of maintenance work such as the following:

- Routine servicing
- Routine maintenance, e.g., inspect/check/adjust
- Corrective work arising at first line
- Existing backlog
- Condition monitoring
- Corrective work at second line (workshop) following from inspections
- Breakdowns and work requests. Subsequent repair/replace at first line
- Breakdowns and work requests. Subsequent repair/replace at workshop level
- Field repair teams if separate from previous categories
- Job scoping, costing, planning, and scheduling
- Technical supervision and support at tools level
- Technical support at engineer and specialist technician level including troubleshooting and reliability improvement
- Proactive maintenance, e.g., failure analysis, root cause analysis, conditioning monitoring development
- Data entry
- Data management, setup, analysis
- Modifications
- Installation and commissioning
- De-commissioning and disposal.
- Shutdowns/turnarounds, overhauls planning
- Shutdowns/turnarounds, overhauls implementation and management
- Ancillary and miscellaneous work—e.g., painting the Brownies' toadstools
- Personnel management
- Training
- Travel to and from site and work locations
- Spares and tools acquisition.

19.5.8 Changes in Demand

The considerations just outlined provide a basis for estimating demand for maintenance resources in the planning period. In practice much depends on how extensively the workload has changed from the current year and on how accurate we regard the current year's budget in the first place. If the workload has changed little and the current budget is seen as accurate, then minimal changes will be needed.

Changes to the level of equipment supported must be taken into account. For example, if 10 trucks work eight shifts per week this year, and 14 trucks will be working 10 shifts per week next year, then the budget should increase in proportion. In the case of increased workload those carrying out the work can be

expected to be vocal, but if the workload decreases, they are unlikely to mention it. It is up to management to identify the need for budgetary changes where workload had decreased, and to make the corresponding adjustments.

19.5.9 Direct Labor Estimates—Routine

The requirement for direct labor for routine maintenance can be estimated from the labor content and frequencies of particular routine maintenance activities. Figure 19.11 illustrates this.

19.5.10 Nonroutine and Breakdown Labor Estimate

The labor requirement for nonroutine work, which includes emergency breakdown and deferred nonroutine work, is estimated by reference to history, changes in forecast demand and by judgment. Additionally, breakdown costs can be estimated by considering the major failure modes, the mean time between such failures and the labor requirements per failure. The failures referred to here may combine chance events with cyclic events such as major assembly changes, the need for which can be predicted in broad terms, although the exact time of occurrence will not be known in advance. Figure 19.12 shows an example of nonroutine labor estimates for the various areas of a large mining shovel.

Std. Work Order	Freq/Year	Hours	Mechanical Persons	Mechanical Pers-Hrs/Year	Electrical Hours	Electrical Persons	Electrical Pers-Hrs/Year
9716. 75hr lubrication system	64	0.5	2	64			0
1002 150 hour dipper inspection	32	1	1	32			0
1004 300 hour preventive maintenance	8	3	2	48	6	1	48
1398 600 hour preventive maintenance	4	6	2	48	6	2	48
1393 1200 hour preventive maintenance	2	8	2	32	10	2	40
1381 2400 hour preventive maintenance	1	12	2	24	12	2	24
1010 4800 hour preventive maintenance	1	24	3	72	24	3	72
Totals				320			232

Fig. 19.11 Labor estimates for routine work

19.5.11 Specific Items

We then make estimates of the workloads by trades and other roles for specific activities such as those shown in Fig. 19.13.

Aggregate Maintenance Workload Plan Non-Routine							
Mining Shovel PH-5000							
Asset Block	Mechanical				Electrical		
	Freq	Hours	Persons	Pers-Hrs	Hours	Persons	Pers-Hrs
Propel System	18	4	2	144	2	1	36
Swing System	6	3	2	36	2	1	12
Crowd System	48	2	1	96	1	1	48
Hoist System	48	1	1	48	1	1	48
House Assembly	6	1	1	6	1	1	6
Attachments	48	2	2	192	1	2	96
Air System	48	1	1	48	0	0	0
Lubrication System	24	1	1	24	0	0	0
Electrical System	96	0.5	1	48	2	1	192
Total				642			438

Fig. 19.12 Labor estimates for nonroutine work

	A	B	C	D	E	F	G
1							
2							
3							
4							
5							
6							
7							
8							
9							
10							
11							
12							
13							
14							

Fig. 19.13 Specific items (headings only shown)

19.5.12 In-direct Labor

In-direct labor covers supervision, administration, training, stores, and technical personnel. Requirement for indirect labor must be estimated. Typically, there will be about 4 indirect positions per 10 direct positions. Examples of in-direct labor activities are,

- Supervision
- Technical administration
- General administration
- Training
- Induction, safety
- Systems development, e.g., Asset Management Information System implementation
- Documentation development and maintenance
- Equipment appraisal for acquisition, replacement
- Failure analysis
- Subcontractor management.

19.5.13 Overheads

Identify requirements for facilities and working and office space, consumables, telephone costs, and support for general administrative functions.

19.5.14 The Maintenance Iceberg

Many things in maintenance remain hard to quantify. For this reason, a *zero-based budgeting* approach, that is working the budget out by estimating the work to be done from first principles, is less effective than one would wish. Factors in the hard-to-quantify category include,

- Peaking of workloads for valid operational reasons
- Standby capacity to cover emergencies
- Standby capacity to mitigate against potential expensive downtime of key equipment
- Travel to and from jobs
- Acquiring and awaiting spares and consumables
- Acquiring tools and instruments
- Awaiting the completion of preceding work
- Subcontractor liaison, communication, management
- Acquiring permits
- Awaiting inspections

- Accessing documentation
- Gaining access to equipment
- Delays in bringing mixed trades together
- In-job training
- Diagnostics
- Resolving technical snags
- Obtaining technical advice
- Absenteeism
- Weather delays
- Seasonal variations
- Nonmaintenance activities of maintenance people
- Operator degree of care. Expensive consumables which can be wasted by careless operators should be moved to the production budget. Examples are tires, bucket teeth, ground engaging tools.

The marginal value of changes in the maintenance budget is hard to quantify on the downside as well as on the upside. Given more money, technical people can always find a use for it. On the other hand, the accountants' tendency to try to increase profits simply by making across the board percentage cuts can only work up to a point.

19.5.15 Arrive at the Resource Requirement

From the steps given in this section, arrive at a required capacity for each resource at each line of repair and at each location. The following categories of staff will typically be required:

- Tradesmen
 - Mechanical
 - Electrical
 - Civil, building, rigging
 - Instrument, air conditioning, etc.
 - Laborers
- Planners
- Storemen
- Inspectors
- Supervisors
- Engineering and technical support personnel
- Clerical staff
- Managers
- Data systems support staff
- Contractors.

19.5.16 Correct the Imbalances

Organizations may find that they have evolved into a situation where the workforce is out of balance with needs in terms of numbers, skills, flexibility, and location. Take a hard look for imbalances between current maintenance capacity and planned workload. Relate required work to required capacity by:

- Location
- Trade
- Shift
- Equipment type

Where imbalances occur—and they may not be small imbalances—reassign, reduce, or increase capacity. *Correct the gross imbalances.* Putting this another way, it means that while a totally zero-based budget approach may have its limitations, it is still good to be able to take a zero-based viewpoint in particular areas where there is reason to regard the resources as significantly out of balance. Build the result into the next year's budget.

19.6 Costing

The accounting department will help in converting the resource budget into a financial budget. This will involve identifying the cost rate for various labor categories including on-costs, such as,

- holiday pay,
- sick pay,
- payroll tax
- workplace insurance
- superannuation.

In-direct, operating, and overhead costs must then be added for such categories as,

- Vehicles,
- Tools and equipment
- Spares
- Consumables
- Freight
- Rent
- Rates
- Electricity and gas
- Telephone
- Facilities maintenance
- Insurance
- Office consumables
- Depreciation.

When in-direct costs and overheads are taken into account it is not unusual to find that the total cost of maintenance is in the region of six times the wages cost of the direct labor.

19.7 Survey and Quote

When a major item needs extensive work, a Survey and Quote approach can be used. The extent of work needed is assessed, possibly involving some disassembly, and a scope of work is determined. This is then costed and included in the budget. There must be adequate allowance for contingencies and for materials and overheads. The survey and quote and the subsequent work are often outsourced.

19.8 Budget Cost Control

1. Create a budget in a spreadsheet (or other established system) indicating the various cost categories and the amounts allocated. Figure 19.14 shows an example.
2. Record actual expenditure year to date (YTD) as it occurs.
3. Calculate planned expenditure for rest of year (ROY). In the absence of other information, this can be done as a proportion of the original budget, but it should be adjusted to allow for known factors of future expenditure. These may be increases or reductions relative to the original plan.

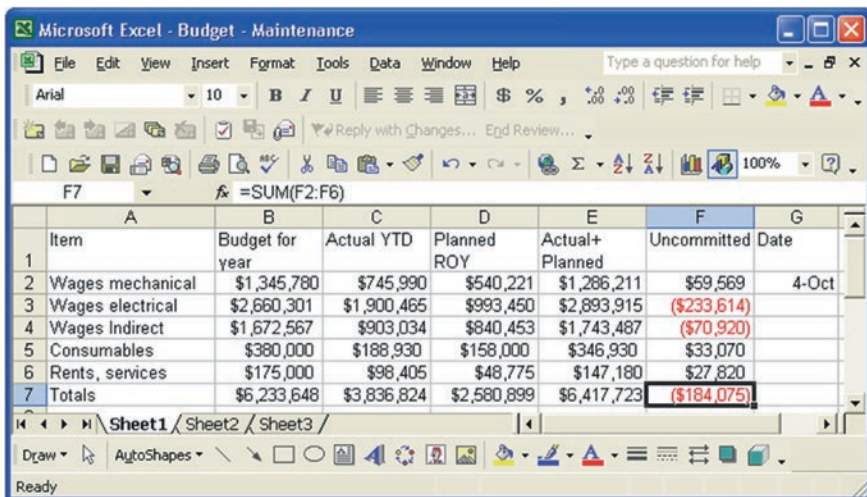
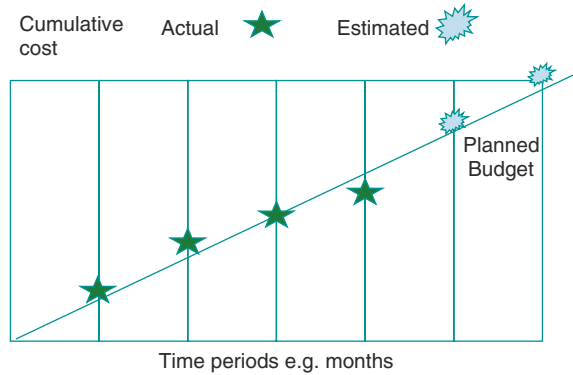

Fig. 19.14 Monitoring budget expenditure

Fig. 19.15 Budget actual versus planned



4. Calculate “uncommitted” money = Budget – (ActualYTD + PlannedROY). This will be a positive amount if there is a projected budget surplus and a negative amount if there is a projected budget shortfall.
5. Take steps to remain within budget, or discuss the situation with management if an unavoidable shortfall or surplus is emerging.

Figure 19.15 shows the budget monitoring process in graphical form. The expenditure planned in the budget is shown as the straight line (though in practice a variable slope may apply if expenditure over the year was not expected to be uniform). As time goes by the actual cumulative expenditure is plotted and the estimated cumulative is also shown, indicating projected expenditure in relation to budget.

19.9 Budget Reports

The following budget reports should be created and monitored on a regular basis, such as monthly.

1. Actual versus planned expenditure to date.
2. Estimated commitments versus remaining budget, giving projected *underspend* or *overspend*.
3. Risk analysis, i.e., significant costs which may occur, and also contingency which may not be required.
4. Informally, finance likes a realistic assessment of how much money will be needed. An overspend is a problem, but an underspend also needs to be addressed, and may relieve problems in other areas. Underspending often occurs due to delays in acquisition of items.
5. Although not specifically a budget report, backlogs in maintenance activity should be reported and monitored as part of the budget management process.

It is important to react in response to the information provided by the reports. Budget changes may be required due to significant changes in commitments.

Backlogs should be acted upon, either by increasing resources in backlog areas or reducing resources if backlogs disappear. Contingency allowances should be retired if risks do not eventuate. Do not cry wolf but be prepared to make a balanced statement regarding risk. Use the unfolding information to refine the budget for next year.

19.10 Activity-Based Costing

Activity-based costing means relating costs for a product, service, or machine closely to the activities needed to support it. This is in contrast to a broad brush approach which allocates overheads in proportion to direct labor, even when a particular overhead may not apply to a particular activity. Activity-based costing is a way of accurately allocating of overheads to the activity they are used on, and not to others.

In activity-based costing we

- Identify the “cost drivers” of each activity.
- Relate costs, and hence budgets and prices for these activities to the drivers.

19.10.1 Examples

In a certain plant, some food products require the use of high pressure steam generated by a boiler system. The boiler system is a cost driver for those products and should be taken into account when estimating their cost.

If activity-based costing is not applied, the cost of the boiler system might be spread over the whole plant (e.g., by absorbing the cost as a general overhead), wrongly inflating the cost of products which make no use of the boiler system. This can make those products appear noncompetitive with rival products in the market place which are not carrying the irrelevant overhead.

Internal invoicing between cost centers can provide a mechanism for assisting with activity-based costing. For example, in a power station which is close to a river it is important to monitor the stability of the foundations of the buildings. Initially, the workgroup monitoring stability of foundations was regarded as a general overhead. When internal invoicing was introduced, the monitoring workgroup invoiced the maintenance workshop for monitoring their foundations. The maintenance workshop was in an area that was not subject to instability and did not have its foundations monitored. They refused to pay and their refusal was upheld by senior management. Had they been required to pay for the monitoring of foundations as a general overhead, it would have artificially inflated their costs and made it hard for them to compete for outside work.

19.11 Exercises

19.11.1 Self-Assessment Exercise

1. What is the aim of maintenance?
2. Describe the following types of maintenance activity:
 - a. Routine
 - b. Emergency
 - c. Deferred
 - d. Preventive
 - e. Predictive
 - f. Corrective
 - g. Proactive
3. What is zero-based budgeting?
4. What steps form the basic logic of maintenance budgeting?
5. What is maintenance backlog and what part does it play in budgeting?
6. What factors in addition to direct labor go into the cost of maintenance?
7. How would you monitor budgetary expenditure?
8. What is Activity-Based Costing?

19.11.2 Maintenance Budgeting Exercise

Pacific Plant Management maintains a large fleet of earth moving equipment. You are creating a maintenance budget for the coming year. The following data are available for the current year (Table 19.1).

The direct labor cost rate is \$30 per hour with a multiplier for on-costs and overheads of 2.75. For the next year an increase in activity of 24 % has been forecast for all equipment types. A contingency allowance of 15 % is applied to the basic budget. What should the total maintenance budget be for the coming year.

19.11.3 Pacific Earth Moving Part 5: Maintenance

Pacific Earth Moving is in the process of acquiring a substantial amount of additional plant. The company has identified an area of profitable business in supporting mining

Table 19.1 Estimated maintenance hours and materials

Equipment type	Routine labor hours	Nonroutine labor hours	Spares and consumables
Trucks	30,000	10,000	\$195,000
Loaders	25,000	12,000	\$185,000
Excavators	28,000	15,000	\$205,000

and oil and gas industries. This involves providing equipment on contract, with full logistic support to major companies operating in remote and rugged terrain. The company needs to boost its maintenance support activities to meet this challenge. Your group has been retained to provide recommendations on the following issues:

- (a) What organization is needed to manage the maintenance of the equipment?
- (b) What functions will the maintenance organization need to provide?
- (c) How would you establish a budget for this maintenance activity?

Present your answer using charts and dot points.

19.12 Exercise Solutions

19.12.1 Self-Assessment Exercise Solution

1. *What is the aim of maintenance?*

The aim of maintenance is to deliver availability of machines and equipment to production or service departments, within the envelope provided by underlying machine condition and the available maintenance resources.

2. *Describe the following types of maintenance activity?*

Note These types of activity are not necessarily mutually exclusive, for example, condition monitoring is typically “predictive” and “routine.”

- a. *Routine* Work carried out on a regular basis. Includes cleaning, lubrication, inspection, servicing, condition monitoring.
- b. *Emergency* Action that must be carried out promptly in response to an urgent situation, may or may not involve actual breakdown.
- c. *Deferred* Corrective work which can be carried out at a convenient time, in contrast to “emergency.”
- d. *Preventive* Maintenance aimed at preventing failures. Lubrication, servicing, etc.
- e. *Predictive* Maintenance aimed at predicting potential failures. Condition monitoring.
- f. *Corrective* Maintenance to correct known faults. May be Emergency or Deferred. Covers all activities other than routine. Includes activity carried out following conditions identified by reporting, inspection, monitoring, or breakdown.
- g. *Proactive* Root cause analysis and improvement activities.

3. *What is zero-based budgeting?*

Zero-based budgeting is calculating a budget from first principles based on the current requirements of the business. In this approach, every item of the budget must be justified from first principles. During a pure zero-based budgeting process, no reference is made to the previous level of expenditure. This is in contrast to incremental budgeting which focusses on variances from past years based on the assumption that the baseline is approximately correct.

4. *What steps form the basic logic of maintenance budgeting?*
 - a. Start with the production plan
 - b. Machine requirements of the production plan
 - c. Maintenance requirements of the machines
 - d. Convert the maintenance requirements into costs
5. *What is backlog and what part does it play in budgeting?*
Maintenance backlog is work which is either overdue or which is required to be done but has not yet been started. The budgeting process should allow for catching up with excessive backlog.
6. *What factors in addition to direct labor go into the cost of maintenance?*
 - a. In-direct labor
 - b. Overheads
7. *How would you monitor budgetary expenditure?*
 - a. Create a budget in a spreadsheet (or other established system) indicating the various cost categories and the amounts allocated.
 - b. Record actual expenditure as it occurs.
 - c. Calculate planned expenditure for rest of the year. There may be increases or reductions relative to the original plan.
 - d. Calculate “uncommitted” money. This will be a positive amount if there is a projected surplus and a negative amount if there is a projected shortfall.
 - e. Take steps to remain within budget, or discuss the situation with management if an unavoidable shortfall or surplus is emerging.

What is Activity-Based Costing?

Activity-based costing means relating costs for a product, service, or machine closely to the activities needed to support it. This is in contrast to a broad brush approach which allocates overheads in proportion to direct labor, even when a particular overhead may not apply to a particular activity. Activity-based costing is essentially an accurate way of allocating overheads.

19.12.2 Maintenance Budgeting Exercise Solution

$$\text{Cost} = \text{Direct-labor hours} \times \text{Cost rate} \times \text{Multiplier} \times \text{Annual increase}$$

Example: Routine for Trucks = $30,000 \times 30 \times 2.75 \times 1.24 = \$3,069,000$

Equipment type	Routine \$	Nonroutine \$	Spares and consumables	Total \$
Trucks	3,069,000	1,023,000	\$241,800	4,333,800
Loaders	2,557,500	1,227,600	\$229,400	4,014,500
Excavators	2,864,400	1,534,500	\$254,200	4,653,100
Total	–	–	–	13,001,400
Contingency	–	–	–	1,950,210
Total budget	–	–	–	14,951,610

19.12.3 Pacific Earth Moving Part 5: Maintenance Solution

a. See

Fig. 19.1 Maintenance organization,

Fig. 19.2 Maintenance services and

Fig. 19.3 Maintenance layout.

b. See

Fig. 19.4 Data flows in the maintenance management application,

Fig. 19.5 Work management activities and typical roles,

Fig. 19.6 Job scoping, planning, scheduling, controlling.

c. See

Fig. 19.10 Basic logic of the maintenance budget,

Fig. 19.11 Labor estimates for routine work,

Fig. 19.12 Labor estimates for nonroutine work,

Fig. 19.14 Monitoring budget expenditure.

Supporting points from Sect. 19.5.

Chapter 20

Stock Control

Abstract The aim of this chapter is to describe the various aspects of inventory management required for asset management. This starts from the initial purchase of spare parts and consumables, and continues with through-life support. Inventory control methods are presented for routine demands and for fast and slow moving spares and insurance spares. *Outcomes* After reading this chapter, you will be aware of the main issues that confront asset managers in regard to spare parts and consumables inventory. You will know everything that is worth knowing about spare parts inventory management, but this will not mean that you can solve all the problems.

20.1 Introduction

The term inventory is applied to stocks of items such as finished goods, work-in-process materials, consumables, and spare parts held by an organization in order to carry out its business functions. The management of inventory extends to cover items which are on-order and are known as dues in, and items which are required by users but not yet available from the store, which are known as dues out, as well as to those items which are physically in stock at any given moment. In the asset management area, the items involved are typically:

- Consumables such as fuel, oil, lubricants, and chemicals.
- Spare parts.
- Rotables, which are items that are changed out, then repaired, and returned to store; this may include complete equipments.
- Insurance spares, that is items which we may never need but which we prefer not to risk being without.

20.2 Aims of Inventory Management

The primary aim of inventory management in the field of spares and consumables is to enable the meeting of requirements for equipment availability at minimum overall cost. This will involve:

- Keeping service to the users at a reasonably high level
- Keeping inventory investment reasonably low
- Cost-effective purchasing.

A balance must be struck between these conflicting factors.

More basic aims of inventory management are to ensure that:

- Stock identity, quantity, and location are known;
- Stock is secure;
- Items are available and accessible when required;
- Purchase orders are placed promptly;
- Goods are received and checked efficiently and effectively.

20.3 Initial Spares Purchase

When a new equipment is acquired, we normally purchase an initial quantity of spare parts. This may be based on the manufacturer's recommended spares list, or on input from experienced maintainers. The acquisition budget should include funding for the initial spares purchase. An amount in the range of 5–10 % of the main equipment budget is typically allocated. The initial purchase or “scaling” is based on a planning horizon such as 3 years. Major spares, such as replacement engines and gearboxes, which may go out of production by the time they are needed, should also be included. It is hard to get it right on forecasting demand and some over and under supply must be expected.

20.4 Cataloguing

Parts will be identified by means of a part number within the organization's inventory management system. It is therefore necessary to catalog the items which the organization will hold. An agreed system of codification will need to be adopted. The equipment manufacturer will normally provide a parts list for spare parts which will include parts explosion diagrams and part numbers. However, if these are to be incorporated into a company inventory system, it will be necessary to catalog the parts under the company's part numbering system. The computer record will normally also contain the identification of the manufacturer and the

manufacturer’s part number. Resources will be needed for the cataloguing activity and for maintaining the computerized inventory management system.

20.5 Inventory Management Basics

A flowchart of inventory transactions is shown in Fig. 20.1. Inventory management is invariably based on a computer system and will be part of an Asset Management Information or Computerized Maintenance Management System. Knowing the current status of any given item requires a comprehensive, online transaction processing, inventory management information system. Up-to-date and accurate information is more valuable than any theory.

The following points are counsels of perfection for inventory management.

- Have one person responsible for the inventory management system.
- Provide an adequate computer system and personnel for system support.
- Maintain security, particularly in regard to attractive items.
- Have an effective coding and cataloguing system with unique part numbers.
- Maintain stores accuracy in regard to quantities, locations, and item descriptions.
- Establish bills of materials and where-used data.
- Ensure work orders contain all spares and materials required for the job.
- Establish and use strict procedures for receipt and issue of stores.
- Have a system which allows 24/7 access to spares for urgent maintenance jobs.
- Establish and use strict procedures for the timely reordering of stock.
- Maintain the computer system in regard to updating supplier and stock records. Ensure staffing is adequate to sustain this.
- Carry out regular stock-takes, usually on a cyclic basis.
- Make stores records visible to users. Extend this company-wide, and have a transfer system between locations.
- Establish data for average demand and for specific project demands.
- Establish item criticality. Have a system for keeping this information up-to-date.
- Set reorder parameters.
- Eliminate dead stock.
- For fast moving items, establish Just In Time delivery procedures.

Fig. 20.1 Inventory system

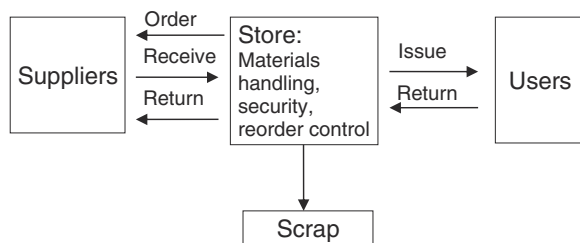

20.5.1 Stock Keeping Units or SKUs

An SKU is a point at which a given item is stocked. A company may have 10,000 different types of item in inventory, but some of them may be held in more than one place. So if the main store is in Melbourne and it holds all 10,000 types of item and there is a subsidiary store in Upper Wup Wup which only holds a subset, say 4,000 types of item, then the company has 14,000 SKUs. The number of SKUs gives a measure of the total size of the inventory management side of the business.

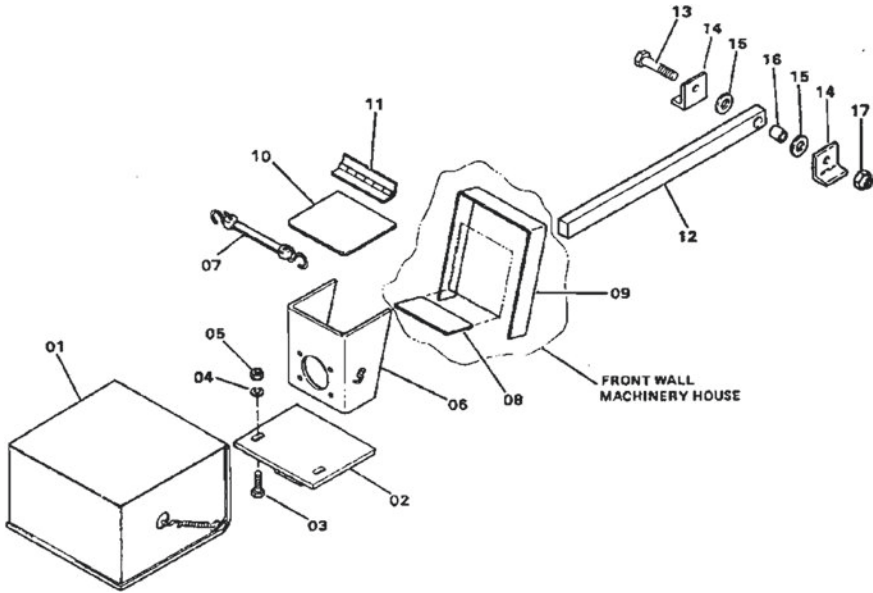

Fig. 20.2 A parts explosion diagram

Ref	Part No.	Description	Qty.
0	100J6493F4	Installation, Boom Limit Switch	1
1	979J23F1	Switch, boom limit	1
2	16N3651D1	Bracket, support	1
3	20Q260D329	Screw, Hex Head Cap 1/2-13UNC X 1-3/4in	2
4	3616V011	Washer, lock, 1/2in	2
5	20Q270D32	Nut, 1/2-13UNC	2
6	16N3649D1	Bracket, mounting	1

Fig. 20.3 Extract from a parts catalog

20.5.2 Spare Parts Catalog

Basic elements of spare parts data for engineering equipment are the spare parts explosion diagram and spare parts catalog listing, examples of which are shown in Figs. 20.2 and 20.3.

20.6 Procedure When an Item Is Needed

The basic steps involved when an item is needed from inventory are as follows:

- a. An item is needed;
- b. Get the part number. Refer to the spare parts explosion diagram and the catalog;
- c. Is the item in stock?
- d. If so, where is it? Pick the item from the location;
- e. Follow the issue procedure, documenting the issue;
- f. Do more items need to be ordered? This will be the case if there is insufficient in stock, or if the withdrawal takes the stock level below the reorder point;
- g. If so, how many should be ordered? The order quantity may have been set in the inventory system, but enough should be ordered to cover foreseen requirements;
- h. Follow the reorder procedure. Get the supplier details. Initiate a purchase order;
- i. If the supplier is not already in the system an entry must be created.

20.7 Stock Status and Control Terminology

To find out if the item is in stock we will refer to a computer screen similar to that shown in Fig. 20.4.

Date:	18 Sept 97	Time:	14:47:05	Location:	BIN 46
Parent Item:	P & H Shovel	Manufacturer:	Hamischfeger		
Part Number:	16W316D1	Description:	BRACKET, Mounting		
Manufacturers Ref:	BLS06	Unit:	EACH	Lead Time Days:	14
Reorder Level:	1	Reorder Qty:	2	Unit Cost:	\$153.07
YTD Used:	1	Last Activity Date:	30 Aug 97		
Current Stock Level:	0	Net Level:	0		
Dues In			Dues Out		
Date	PO No.	Qty	Date	WO No.	Qty
3 Sept 97	PO4371	2	12 Sept 97	WO123	1
			18 Sep 97	WO234	1

Fig. 20.4 Inventory status report screen

Part No: A43WS582-Grease. Unit: kg; Date: 05Jul Time: 10:15
Lead Time Days: 28 Supply Multiple: 50 Supplier ID: 3427

Row	Date	Note	Due In	Due Out	Net Level
1	06JUL	Stock			13
2	06JUL	PO-123	50		63
3	10JUL	WO-456		25	38
4	19JUL	Dragline Servicing		50	-12 **
5	28JUL	PO-145	100		88
6	01AUG	Ballmill Servicing		25	63
7	10AUG	Shovel Servicing		35	28
8	17AUG	WO-475		45	-17 *

** = Shortage within one lead time. * = Shortage within two lead times.

Fig. 20.5 Materials requirements planning report

In Fig. 20.4 the following terms are used, and play the roles indicated as follows:

- Current Stock Level* The number of items in stock.
Dues In Items ordered from a supplier but not yet delivered.
Dues Out Items demanded by a user, but not yet issued.

Dues out can include items not yet ordered from a supplier, items ordered from a supplier but not yet received, and items received but not yet issued. These items may be referred to as “committed,” as they are already known to be demanded by specific users.

- Lead Time Days* The time between ordering and delivery.
Net Level Current Stock Level + Dues In – Dues Out.

The net level is the stock level that we shall have if we add the dues in to our existing stock and then subtract the dues out. It is the balance of our stock situation allowing for existing planned stock movements. If the result is below the *reorder level*, an order for the *reorder quantity* should be placed.

Another term which is used is:

- Backorder* An item is on *backorder* or *backlogged* if it is not in stock, has already been ordered from a supplier, but the order has not yet been received.

20.7.1 Multiple Locations and Status Settings

It is easy to grasp a situation where items are either in stock or not. However, variations on the theme arise in practice. Computer systems need to allow for many possibilities but this can make the situation less clear than you might wish. A given

stock item may be held in a number of locations. Also the status of the item can have variations, such as:

Received but not cleared into stock,
In transit,
In stock but reserved for a project,
In stock but reserved for emergency,
Assigned for disposal.

Transactions between these and other status categories at all the various locations can lead you to use a little black book in which you keep track of the things you really want to know about. This is not defensible in theory.

20.8 Dependent Demand

Dependent demand is demand which can be estimated or planned, by time and quantity, from a production plan or a scheduled maintenance plan. Examples are:

- The consumption of fuel, for a known vehicle fleet operating to an established production or delivery schedule.
- Consumption of chemicals or other consumables used in a number of routine or planned applications.
- Spares such as spark plugs or brake pads used in an established scheduled maintenance plan.
- Spares which are ordered for a known repair, or for a shutdown involving planned replacement of components.

If dependent demand is quite regular it can be managed by routinely ordering quantities sufficient to cover the demand. Occasional variations from average will be dealt with by varying the order and by holding a safety stock.

20.8.1 Kanban System

The initiation of the reorder process may best be handled by a Kanban system. In a Kanban system the reduction in stock below the reorder level is indicated by a physical card which is released when the critical stock level is reached. This is theoretically the same as an electronic signal, but the physical card can be easily recognized. The card will indicate the quantity to be reordered.

20.8.2 Materials Requirement Planning (MRP) Report

If demand is dependent mainly on known but irregular activities, we use a Materials Requirements Planning (MRP) analysis and report of the type shown in Fig. 20.5. The item referred to in that example is a type of grease, purchased

in multiples of 50 kg, which is used in servicing major machines such as mining shovels, draglines and ball mills.

In Fig. 20.5 the rows correspond to planned events in date order. The first row shows the opening stock which is 13 kg and this quantity appears in the Net Level column. Existing purchase orders provide data for the Due In column. Row 2 shows that we currently have 50 kg Due In under Purchase Order PO-123 on 6 July. The Net Level column shows the projected stock after each planned transaction. In row 2 the Net Level is 63, as the 50 kg from the PO-123 are added to the stock of 13. The data for the Due Out column is created from the current utilization plan. The next planned event is a Due Out of 25 kg required on 10 July by Work Order WO-456, which will reduce the Net Level to 38 kg.

The report continues projecting forward the Dues In and Dues Out, running as far ahead as we choose to plan, usually at least two delivery lead times ahead. In this case, the lead time is 28 days so we will plan for 2 months ahead. The Net Level column will eventually show a shortage, represented by a negative net level. This is an indication that we need to take action so that the shortage is prevented. If the shortage first occurs more than one lead time ahead, we cover the shortage by placing an order. If a shortage occurs within the normal lead time, we need to take special action. This may be placing a rush order, delaying the lowest priority use, or providing a partial quantity to one or more demands.

Every change in the supply or demand situation requires a revision of the Materials Requirements Planning Report. However, in practice it is usually sufficient to generate a new report at a convenient regular interval such as daily for critical items or weekly for noncritical or slow moving items.

20.9 Independent Demand Items

Independent demand items are items for which demands occur on a variable basis, such as spare parts required for unpredictable breakdown repairs.

20.9.1 Fast Moving Items

For fast moving independent demand items, a typical cycle of stock level from order to reorder is shown graphically in Fig. 20.6.

The stock level is shown vertically and time is shown horizontally. The stock level following an earlier delivery starts at some initial value as shown on the left-hand axis, and then falls irregularly over time. The current net stock position is monitored, and when it falls below the *reorder level*, an order for a *reorder quantity* is placed. There is then a *lead time* after which the order is delivered. The stock then increases by the reorder quantity and a similar cycle of events is repeated. Control of the stock is effected by setting appropriate values for the reorder level and reorder quantity.

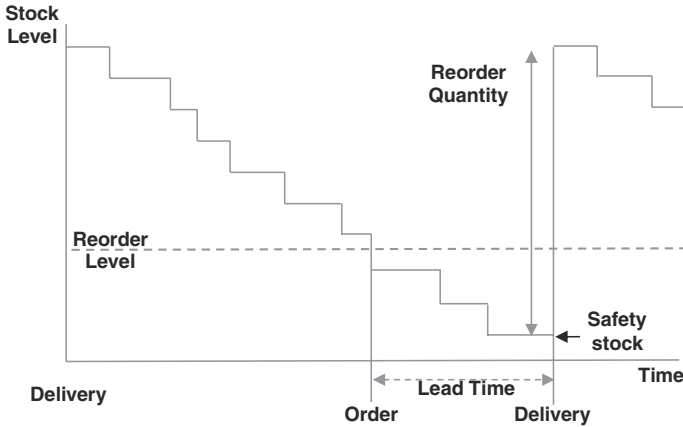

Fig. 20.6 Fast moving items—reorder cycle

20.9.2 Reorder Level

The reorder level is a stock level such that, when the net stock falls below it, an order should be placed. The *reorder level* is represented by the horizontal dotted line in Fig. 20.6. A guideline value for the reorder level is twice the average demand in the lead time.

20.9.3 Lead Time

Lead time is the time taken from when the net level falls below the reorder level until the item becomes available for issue. The estimate of the lead time should include:

- Time that it takes us to identify that stock has fallen below the reorder level
- Time taken to place the order
- Time from the supplier receiving the order to delivery
- Time taken from delivery until the item is available to a user, e.g., checked in and placed on the shelf.

During the lead time stock will continue to be used. The average amount of stock used in the lead time is known as the average lead time demand, or simply as the lead time demand. The reorder level should be set to a level which will usually cover the lead time demand, so that no actual stockout occurs. However, if the reorder level is high, it will mean that excessive stock is often being carried. A guideline value for the reorder level is twice the average demand in the lead time.

20.9.4 Reorder Quantity

The reorder quantity is the quantity to be ordered. This is typically a convenient handling quantity of 1–3 months demand, with possible consideration of quantity discounts. However, even with discounts it is rarely worth ordering more than 1 year's supply.

20.9.5 MIN and MAX

The stock control process may also be presented in terms of minimum (MIN) and maximum (MAX) values. MIN is the same as the reorder level, so that an order is placed if the net level is below MIN. MAX is a maximum stock level. MAX can be regarded as similar to the reorder quantity, but it also gives the stock controller the option of ordering a varied amount if the circumstances call for it, so that we order enough to bring the stock up to MAX.

A great deal of statistical analysis has gathered in the literature about stock control, but as a rough guide, the reorder level or MIN should be twice the demand in the resupply lead time. The reason for this is that this policy will cover the possibility that something goes wrong in the reorder process. The fault will be identified after one lead time, leaving a second lead time for the mix up to be rectified.

The reorder quantity or MAX should be a convenient ordering and delivery quantity, sufficient to cover demand for a readily foreseeable period ahead, such as 1–3 months.

20.10 Target Level

A variation on the MIN and MAX method of stock control is the Target Level method. In a target level policy, if at the time of ordering, the net level is below a set target level, then sufficient is ordered to bring it up to the target level. This approach is convenient if routine deliveries occur with the quantity to be ordered being flexible from delivery to delivery. Regular milk deliveries and weekly grocery purchasing are examples. In this method, the MIN level is not used but the MAX level acts as a target. If the net level is below MAX, then sufficient is ordered to bring it up to MAX. With all methods, adjustments may need to be made for exceptional demands or shortages.

20.11 Forecasting

Scientific reorder control for independent demand items depends on estimates of the average demand per month and the average resupply lead time. These parameters can vary through time and a forecasting system, or more truthfully, a demand

tracking system should be used to track variations in the demand. The simplest systems are based on calculating a *moving average* of demands. The average will rise or fall as demand changes and the reorder level and reorder quantities should be linked so that they follow the changes.

For spare parts, the *exponentially weighted moving average*, or *exponential smoothing* method is recommended. It has the advantage that, in the case of *slow movers*, it will vary gradually, whereas a 12 months moving average, for example, would fall to zero after a year with no demand.

Besides variations in the level of demands, there can be seasonal variations and trends. Changes in trend are difficult to deal with automatically and may require human intervention to correct the forecasts. Another difficulty is outliers, that is, exceptional circumstances which may rarely if ever repeat. A classic in the Australian bush is the demand for fencing wire, for which a bush fire running through a region can cause a once-in-a-lifetime outlier in demand.

Lead time variations are more likely to be caused by administrative changes; for example, changes in supplier, in the delivery system, or the communication system. Shorter lead times are beneficial in providing a more responsive system. Long lead times due to shipment by sea need a more strict attention for lead time estimation.

20.12 Reorder Risks

Risks to the smooth running of the reorder process include:

- a. Failure to identify when the net stock level has fallen below the reorder level or MIN
- b. Lumpy demand causes a shortage
- c. Failure to place the required order
- d. Wrong item ordered
- e. Order not received by supplier
- f. Order not acted on by supplier
- g. Wrong item sent
- h. Loss in transit
- i. Item wrongly identified
- j. Item faulty at reception quality check
- k. Item misplaced or lost on site
- l. Item faulty when brought into use.

These risks are often more significant in practice than any fine tuning which may be achieved by statistical approaches to reorder level setting.

20.13 Inventory Faults

Some common faults in the management of inventory are as follows.

- Items not assigned a formal location but kept in casual or inconsistent locations;
- Item location not recorded;
- Item kept in multiple locations for no valid reason;
- Item not in computer inventory system;
- Item not in purchasing system;
- Description of items is missing or incomplete;
- Varied descriptions or codings for identical item;
- Part number, manufacturer, or manufacturer part number not specified;
- Hazardous conditions not specified;
- Stock control parameters not specified (Max and Min or reorder level and reorder quantity);
- Lead time for resupply not specified;
- Shelf life not specified;
- Default supplier not specified;
- Last or current purchase details not readily accessible;
- Freight company not specified;
- Stocktake not performed, incomplete, or not recorded; and
- Items held informally by various people.

20.14 Safety Stock

The expected level of stock remaining at the end of the lead time is known as safety stock. If the reorder level is twice the average lead time demand, as recommended, the safety stock is equal to the average lead time demand. When the lead time elapses, we expect the item to be delivered. If it is not, then we should check why. If the order is not on track, then the safety stock will provide cover for an additional lead time in which to get supply.

20.15 Item Criticality

Critical items are items that are particularly essential to the operation of the organization. Reviewing item criticality requires a knowledge of which machines and processes are most critical to the business. Critical items will normally be:

- Consumables that are essential for mainstream operations,
- Spares that are essential to maintain mainstream plant.

Criticality can be dealt with by increasing the reorder level (or MIN) where criticality is identified. As a guideline, increase the reorder level by 25 % and round

up to the next integer value. So a noncritical reorder level of 5 will become a critical item reorder level of 7. For critical dependent demand items, use the Materials Requirements Planning method shown in Fig. 20.5.

20.16 Summary of Reorder Rules Fast Moving

Reorder Level or MIN = 2 * average lead time demand, rounded up.

Reorder Quantity or MAX = 1–3 months demand, rounded to a convenient purchase quantity.

For critical items increase quantities by 25 %. Do not order more than will last for the shelf life.

20.16.1 Stock Control Example

An item has an average demand of 4 per month and a lead time of 2 weeks. What MAX and MIN values should be set?

Solution: Take the 2-week lead time as corresponding to half a month. The average demand in the lead time is 2.

We set MIN = 2 * average demand in lead time = 2 * 2 = 4

We choose to set MAX to be 3 months demand, MAX = 12.

Thus the control parameters are:

MIN = 4

MAX = 12.

20.17 Current Action

Stock levels must be reviewed, ideally at every issue, or on a frequent regular basis, e.g., daily.

At any time we may have:

- Stock on hand
- Dues In
- Dues Out
- Special Demands.

We should place an order if:

$$(\text{Stock} + \text{Dues In}) - (\text{Dues Out} + \text{Special Demand}) < \text{MIN} \quad (20.1)$$

The actual reorder quantity should be enough to take the net level, allowing for dues in and out and for any special demands, up to the MAX level.

Thus we have:

Net Level = Stock + Dues In – (Dues Out + Special Demand)

If Net Level < Reorder level then:

Actual Reorder Quantity = Max – Net Level

Round to allow for a Supply Multiple.

20.18 Complications

Several additional factors make stock control complicated and make fully automated control difficult. These include:

- *Supply multiple* Supply may be in quantity multiples which are convenient for packaging or transportation. A choice between available supply quantities will have to be made. For example, oil in 20 L cans or 200 L drums.
- *Price breaks* Price breaks occur depending on order quantities. The cost of oil per liter will be lower in 200 L drums than in 20 L cans. A decision to increase the reorder quantity to take advantage of a price break may be needed.
- *Issue multiple* Items are issued in multiple quantities, for example spark plugs. The multiple may be different for different applications, e.g., four- or six-cylinder engine.
- *Issue quantity is variable* The issue quantity varies from job to job, for example when an item is stripped down in some cases new seals may be used but in other cases, the existing seals may be left in place or reused or partly so.
- *Reserved stock* Items required for a critical machines, specific repairs, specific projects, or for a shutdown, may need to be held in reserve; otherwise, when the breakdown or shutdown occurs, the items will no longer be available and a major delay in can occur.
- *Kits* Some items form part of kits of components which are issued in a set to carry out certain repairs. When a kit is issued, a new kit should be prepared, and this will draw stock from the item store. Kits may sometimes be returned partly used, in which case the kit should be replenished. Kits may be raided for components in an emergency (oh no!).
- *Shelf life* The time for which an item can be stored before it deteriorates. This may be an issue. Do not order so much that the shelf life is exceeded. To avoid items lingering in the store, arrange for *first-in-first-out*, or *FIFO*, use of items.

20.18.1 Consignment

Stock on consignment is stock that suppliers provide into store, which is only invoiced as it is used. This can have advantages for the user who is not committed to unused stock. It can also suit a supplier who gets a guaranteed customer and perhaps also gets free storage.

20.18.2 Cannibalization

This term refers to a situation where we have two items of equipment which require different spares, and the spares are unavailable. We can take spare parts from one item in order to get the other one working. This is not an ideal situation but it may be the only practical resolution to return a needed item to production in a hurry.

20.18.3 Returned Stores

Returned stores are generally a curse but may sometimes be a blessing. The condition of returned stores may be hard to assess, and using them may give rise to safety problems. In the case of technical items, expertise is needed to identify and assess them and it is often not practical or economic to provide this. On the other hand, a scrap yard of returned stores or scrapped items may provide the only source of spares for old equipment. Where else will you find an authentic gearstick knob for your 1935 Chevy?

20.18.4 Storekeeper Personnel

Employ ex-tradesmen in the stores. They understand the equipment, are sympathetic to the needs of operations and maintenance, and have the interests of the industry at heart. Young blokes off the street will know nothing—initially.

20.18.5 Overstocking

Stores people tend to be criticized more for shortages than for overstocking, so the tendency is to overstock.

20.19 Repair Pools and Rotables

A repair pool is a number of additional machines, assemblies, or components which are provided on a standby basis. When a failure occurs, an item from the repair pool is quickly brought into service. The failed item is then repaired and returned to the repair pool. Repair pools can significantly increase system availability at moderate cost. The items are referred to as *rotables*. Figure 20.7 illustrates the process.

It is important to initiate the repair cycle promptly. Sometimes the rotatable is left languishing in a corner, with no replenishment action taken until a crisis occurs.

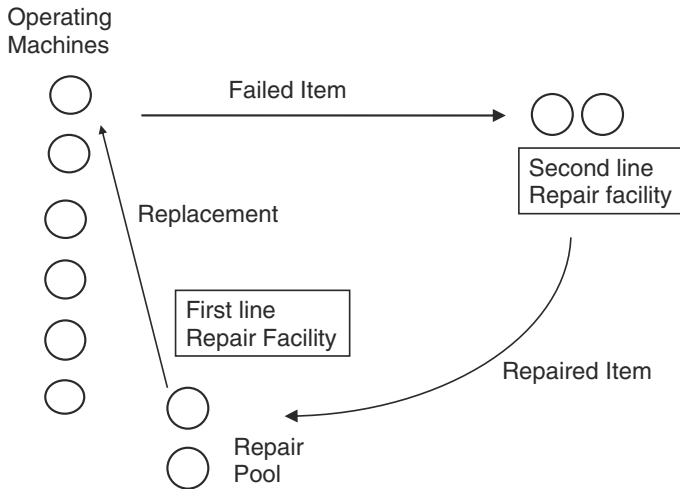

Fig. 20.7 Repair pool and rotables

In some cases, only the owner's own assemblies (identified by serial number) are returned to the owner's pool. A repair facility which deals with many customers (e.g., as an agent for a major OEM) may supply rotables which are not necessarily those which the owner has sent for repair, so that the failed item is really a financial trade-in. In this case, the mean time to replenish the repair pool may be less than the time to turn around a specific rotatable. A judgement needs to be made regarding the appropriate lead time to use in estimating the size of the repair pool. As a guideline, the size of the repair pool should be twice the number of failures expected in the turnaround lead time. For critical items, one or two extras may be carried.

20.19.1 Repair Parts

Repair parts are items which are sent for repair to a higher echelon, but no repair pool is kept. The item is out of service while the repair is being carried out. In-between situations can arise if the repair part is replaced from stock or by cannibalization, but normally the user awaits the return of the repair part.

20.20 Slow Moving Items

A slow moving item is an item where the mean time between demands is much longer than the lead time. As a guideline, if the mean time between demands is more than ten times, the average lead time then the item is slow moving. Thus an item with an average demand of 1 per year and a lead time of 1 month is slow

moving. The *mean lead time demand* is the average demand in the average lead time. An item is slow moving if:

$$\text{Mean Lead Time Demand} < 0.1$$

For slow moving items, the probability of multiple demands in the lead time is very small. On the basis of the guideline just given, it is less than 0.01, assuming that demands are independent. Classify slow moving items into the following categories:

- “*Stock Zero*” items. Do not hold stock. In this case, you have to wait for delivery every time. This is also described as Order Only On Demand (OOD).
- “*Stock One*” items. This is the default. Usually have 1 in stock. Order when stock reaches zero (MIN = 1).
- “*Stock Two*” items. Items for which extra safety stock will be held. Usually have two in stock. Order when stock reaches 1 (MIN = 2).

The choice of category for any given item is based on the following factors:

Demand Rate Low values reduce the holding. A mean lead time demand of less than 0.01 will usually result in a “Stock Zero” decision, that is, orders are only placed when a demand for an item eventuates. But consideration should be given to holding the item as an insurance spare, in which case we will have a “Stock One” policy.

Item Cost A high cost reduces the holding; for example, a high cost may result in a stock-two item being reduced to the stock one category.

Shortage Cost/Criticality Higher values of shortage cost or high criticality will increase the holding. This may push an item from the “stock zero” to the “stock one” category, for example.

Lead Time A long lead time increases the holding.

Safety and Environment Potential problems under these headings increase the holding.

The decision as to whether to hold stock of a slow mover, and if so, whether to hold one or two items can be assisted by considering the guidelines summarized in Fig. 20.8. Consider each factor in turn and tick one of the columns in regard to that factor. If none of the factors is compelling in terms of holding stock, then we would take the “No stock” option. Otherwise, the placing of the ticks might indicate that we should hold a stock of one or two. If it is really important to avoid a shortage and none of the other factors override this, then we may stock two.

Factor	No stock	Stock 1	Stock 2
Demand Rate			
Item Cost			
Shortage Cost/Criticality			
Lead Time			
Safety/Enviro			

Fig. 20.8 Guidelines for policy analysis for slow movers

20.20.1 Example

A consultant uses a printer which requires ink cartridges. The demand rate and lead time are low and the item cost and safety are not significant. However, the shortage cost or criticality, in terms of a cartridge running out at an inconvenient time is assessed as significant, so the decision is to Stock 1 cartridge (of each color).

20.21 Insurance Spares

An “insurance spare” is one where the probability that it will be needed is low, but the consequence of not having it is high, so on balance we decide to hold it. The item need not be high cost. In fact, low cost is an argument in favor of holding a spare.

For high cost and high shortage-cost items, have a contingency plan. This may involve:

- holding a spare equipment, this is an insurance spare.
- sharing this with others.
- arranging air freight as a contingency plan for an emergency.
- making a contingency agreement with the supplier.
- having a contingency plan which provides an adequate short-term solution, if feasible.
- setting up inventory and supplier file entries so that the purchasing process can proceed promptly when the part is needed.

20.22 Summary of Policy Types

For a given item, we need to decide what type of reorder policy should be used such as:

- *Independent demand* Reorder Level and Reorder Quantity (= Min and Max);
- *Dependent demand* Material Requirements Planning (MRP);
- *Routine restocking* Just In Time (JIT)/Kanbans; and
- *Slow moving* Zero, One, and Two stock holding policies.

20.23 Performance Indicators

20.23.1 Service Level

The *service level* is the proportion of items supplied at the time required. The service level is a performance indicator. However, the service level only measures

performance from the consumer’s point of view and if it is the only performance indicator used, it will encourage overstocking.

20.23.2 Days Supply

Consideration of the number of days supply of items can help to highlight stocks which are excessive and ones which are in short supply:

$$\text{Days Supply} = \text{Net Stock} * 365 / \text{Annual Demand}$$

Figure 20.9 shows an example of a days–supply report.

Note that Net Stock = Current stock level + Dues In – Dues Out.

Days Supply > 730 is more than 2 years supply, which normally indicates *dead stock* or possibly an insurance spare;

Days Supply > 365 is excessive stock or slow moving;

Days Supply < 365 and > 0 is normal;

Days Supply ≤ 0 is out of stock.

20.23.3 Dead Stock

Dead stock is items for which no future demand is expected. It is likely to be for items which are no longer used. Correct gross anomalies by transferring, writing off, and disposing of stock which is of no further use at a given location. But be careful not to overreact. Some items may be insurance spares or may only be required at long intervals.

Part No - Description	Net Stock Level	Av. Monthly demand	Days Supply
158904 - Bearing	356	0	9999
235611 - Flange	75	2.3	978
SR-24 - Hose	3900	25	156
7034452 – Seal	2	6	10
56902 – Desiccant	23	150	4.6
78/45WY6002 - Pipe	0	5	0
AD670013 – Valve	-3	2	-45

Fig. 20.9 Days–supply report

20.23.4 Stock Turns Per Year

Another indicator of the performance of the inventory system for any given stock item is *stock turns per year*. This is the number of items issued in the year divided by the number held in stock—typically at stock take time.

$$\text{Stock Turns Per Year} = \text{Annual Demand} / \text{Stock Level}.$$

For example, if the annual demand is 40 and the stock level is 10 then the Stock Turns per year is $40/10 = 4$. This analysis can be useful in identifying items with high or low inventory movement.

20.23.5 Value Turns

Another performance measure is *value turns*. This is the annual demand value divided by the stock value at stocktake, taken over a range of stocks. For an individual item this is the same as stock turns. A low level indicates a low turnover rate of stock, which is inefficient.

Taking the Sum over a given range of inventory items:

$$\text{Stock Cost} = \text{Sum} (\text{Stock Level} * \text{Item Cost})$$

$$\text{Annual Demand Value} = \text{Sum} (\text{Annual Demand} * \text{Item Cost})$$

$$\text{Value Turns Per Year} = \text{Annual Demand Value} / \text{Stock Cost}$$

The value turns can be calculated for the entire stock or for sections of it. A useful assessment can be made by calculating the value turns for items in various ranges of days supply. Insurance spares, however, are a special case and should be kept out of the value turns calculation.

The cost-benefit of the current inventory can be examined by analyzing the cost of the stock and the value of the demand for that stock. Items with high stock cost but low demand value per year are poorly performing. These items should be eliminated unless they are being retained deliberately as *insurance stock* against assessed risks.

The example in Fig. 20.10 is based on a vehicle importer who had substantial amounts of dead stock, due to model changes. The dead stock items are those with 365+ days supply. These items also have very low value turns. Similar results occurred in an oil refinery with spares for obsolete plant.

20.23.6 ABC Analysis

Sort the items by Annual Demand Value (or “turnover”).

$$\text{Annual Demand Value} = \text{Sum}(\text{Annual Demand} \times \text{Item Value})$$

Days Supply Range	Stock Cost	Annual Demand Value	Value Turns / Year
0 - 90	\$257,498	\$3,012,543	11.7
91 - 365	\$1,752,107	\$921,191	0.53
365+	\$3,951,228	\$142,201	0.04

Fig. 20.10 Inventory value turns

Group into “A, B, C” classes by Demand Value.

- Class A is items with high demand value (top 20 %)
- Class B items with medium demand value (next 40 %)
- Class C items with low demand value (bottom 40 %)
- Possibly also Class D for zero value = dead stock, but could include some insurance spares. Exclude these from percentages.

Focus most attention on improving the management of the Class A items.

20.23.7 Inventory Improvement Actions

- Eliminate stocks for items no longer in use.
- Retain stock of items which may be needed, even if they are old, slow moving or insurance items.
- Eliminate excessive stocks. Stocks above the (reorder level + reorder quantity) or MAX are normally excessive. Old stock can often deteriorate and cause problems when used.
- Reduce lead times, e.g., by faster freight service, or more frequent review.
- Use surface transport normally but air freight in an emergency.
- Consolidate stock holdings and/or stock level information across sites.
- Get the supplier to hold stock or send stock on consignment.
- Use a Just In Time call off system for steadily moving items.

20.24 Accounting for Inventory

Inventory is an asset. Fast moving inventory, with a turnover period of less than 1 year is a current asset, whereas slow moving inventory is a fixed asset. Categories of inventory include:

Current Assets

- Finished goods including distribution inventory
- Work in Process (WIP)
- Materials—for use in manufacture
- Consumables, e.g., fuels
- Spare parts of a fast moving nature.

Fixed Assets

- Spare parts, slow moving
- Repair parts, e.g., rotatable assemblies
- Insurance spares—held just in case.

20.24.1 Inventory in the Balance Sheet

Inventory of all types occurs as an asset in the balance sheet. Inventory must be funded, that is, we have paid for it, and as it does not generate a return merely by sitting there, it is something which we should try to minimize, provided that we can do so without causing losses to appear elsewhere. This is why manufacturers try to minimize inventory through systems such as Just In Time and Lean.

20.24.2 Inventory in the Profit and Loss Account

The cost of the current asset inventory purchased in the year is part of the costs in the profit and loss statement, while the difference in the inventory value between the start and end of the year also appears in the profit and loss statement of company accounts.

$$\text{EBITDA} = \text{Revenue} - \text{Costs} + \text{Closing inventory } \$ - \text{Starting inventory } \$$$

In an operation which runs at a reasonably uniform pace, the difference between the values of closing and starting inventory will normally be small, so that the significance of changes in inventory value will not be great. However, an apparent profit arising primarily from an increase in the value of inventory over the year should be regarded with suspicion, as the inventory may ultimately not realize its quoted value. People have been known to lose their jobs when they were found out fudging the profit by overstating the value of inventory. Work-in-process inventory and capital developments partially completed, are areas where valuations can be hard to estimate.

20.24.3 Overstocking and Write Downs

For finished goods, an overstocked situation may lead to discounting of the price and hence to an inventory write down which will affect profits. A potential problem, relates to maintenance parts. Fast moving spares are treated as current assets,

but if they do not move as quickly as expected—as often happens—they can accumulate in value on the books. If it then turns out that they are subsequently worth much less than their purchase price, due perhaps to being obsolete, then a substantial write down, and hence loss of profit will occur.

As an example, consider a company which has a fleet of vehicles which uses a particular type of tire. The company buys a supply of tires for the vehicles. Tires are an expense item, that is, a current asset, and the value of tires in stock at the end of the year will contribute to profit. Later the vehicles are replaced by a different model which uses different tires. Tires of the original type which remain in stock will remain as a current asset, but may in fact have no value, in which case a write down will be required. On a small scale, this may be unimportant, but experience suggests that, when accumulated over many assets and a long period of time, the problem can become substantial. Management will be concerned at the cost and timing of a write down as it will reduce profit in the year in which it occurs.

A possible solution to the previous problem is to hold spares as capital items and depreciate them. However, another problem may then arise. Often, spares are charged out to a user, possibly an outside customer or an internal cost center, as they are taken from store. If spares are depreciated, they will be charged out at much less than their purchase price, and the decrease in value will be borne by our company or our cost center. To avoid this, we would need to have a policy of charging out spares at cost. Another thing is that if spares are depreciated, the accountants may want to write them off as of little or no value, when in fact they are essential to keep our major assets working.

Thus there are some tricky issues relating to accounting for slow moving spare parts.

20.25 So How Did We Win?

“Most of your war stories seem pretty negative, Pop,” said Jock.

“Yes,” said Pop. “In fact Hermann, our German storeman in Sennelager after the war, used to tell me that he couldn’t understand how his side lost!

“One day though, a Polish bloke turned up at the store looking hot and bothered. He’d walked about 10 km from where his tank transporter had broken down. A brake jumper lead had failed and it wasn’t safe to drive with the trailer brakes not working. He had the lead in his hand—he asked if we had a spare.”

“We didn’t have tank transporter spares and neither did anyone in the area. I took a look at the lead and figured that we could fix it temporarily by replacing the worn section with a piece of metal tube. I told the Polish driver to go over to the canteen and get something to eat and come back in an hour.”

“I got Chalky White to turn a length of tube to the right size and to fix it into the lead with hose clips. We tested it on the compressed air machine and it was okay. The Polish driver was delighted, and we had a call later that day saying that he had got to his base safely and thanks.”

“It was at a social barbecue later that Hermann said to me that that just wouldn’t have happened in his army. They worked strictly in silos, and there was no way that his regiment would have let a foreigner near their stores, much less gone to the trouble of helping him out.”

20.26 But Problems Remain

“Nothing that I learnt in my Operations Management class ever seems to work,” Veronica complained one day at the water cooler.

I was going to ask what in particular she had in mind, but she went on seamlessly.

“The chlorinator has umpteen types of seal and a different one fails every time. They only cost a few dollars each but any one of them can bring the whole system to a grinding halt. Not only that, but you can’t get them in this country, they have to be imported, and once we have a particular type in store we never need it again!”

I groaned sympathetically. She was feeling pretty stressed—the chlorinator was off-line again.

“I ordered a whole lot of seals for the annual shutdown, but guess what—some person (I think she said person) took a couple out of the store to use on the other line. Now were waiting for air-freight on \$2 worth of items, at \$20,000 an hour down-time.”

“Hmm,” I said, and edged away from the cooler.

.....

A week or so later when things had calmed down, I asked Veronica what she meant about the Operations Management class.

“Well the lectures were all to do with the *standard deviation of the lead time demand* which seemed to be the answer to everything, but there is no chance of getting off first base with that in real life.”

“The first problem is that the technicians want access to the stores 24 h per day 7 days per week. That cuts right across a stack of security issues. So the technicians “expense” a whole lot of stores that they think they might need and squirrel them away somewhere. This completely invalidates any demand data on the computer system.”

“Another problem is that the people who work in the store nowadays, and the computer system people, know nothing about the equipment or about maintenance—it is all just part-numbers to them. Of course it’s not their fault, but if only they *knew or cared* about what was going on in the plant it would make a lot of difference.”

“One thing that we did at Widdecombe,” I offered, “Was to employ ex-trades people in the store. They were all ex-mates of the technicians and understood the plant because they had worked there for years.

“In fact, there is a guy called Tom Cobbley who could do with a job right now, and who knows the refinery really well.”

“Interesting,” said Veronica, “I’ll see what Human Resources says about that idea.”

.....

“I think I know where the academics go wrong,” I said, the next time I met Veronica in the tea room.

“Yes?” she said.

I reminded her about her comments about Operations Management lectures.

“What they do,” I said, “is replace a simple problem with a harder one. For example, if you said to the storeman that it was okay to run out of stock of non-critical items occasionally, he could probably make a fair shot at the correct reorder level. But if you tell him to set the reorder level to the mean lead time demand plus 1.68 standard deviations then you have created a problem that he’s not going to try to solve.”

“I see what you mean,” said Veronica, “but to be fair, the analytical types are trying to cope with thousands of items on some automatic basis. A human being can probably get a better answer if he has time to work on a particular item.”

.....

“I thought that that consultant that we had was a complete idiot, but I can see what went wrong now,” said Veronica a few weeks later.

She knew that I always lent a sympathetic ear to her stories.

“He spent ages setting the reorder levels on the automotive parts inventory, and as soon as he left we began to run out of parts.”

“So was he an idiot or what?” I asked.

“As it happened, just after he left we decided to close the warehouses in New South Wales and Queensland and supply the dealers direct from the main store in Victoria. That completely changed all the demand data and made the reorder levels too low. That’s why we ran out of parts.”

“The consultant wanted to implement a forecasting system which would have updated the demand data, but apparently we were out of budget for consultants and that never happened.”

“So what’s happening now?” I asked.

“We’re in a mess,” she said.

.....

“I hear that you are leaving, Veronica”

“Yes, we’re relocating to Perth. And by the way, I’ve just figured something out on the military maintenance contract.”

“You always figure things out just too late ... oops, sorry. Nothing secret, I hope”

“Not really. Peculiar though. We often had difficulty getting spare parts for the older army equipment until I met up with a secondhand dealer in Melbourne who always seemed to be able to come up with the stuff. The thing I couldn’t get was that it would always take him until ‘next Thursday’ to supply parts—it seemed odd.”

“Then I realized that there was an Army Surplus sale at the depot every Tuesday. He was buying old stores from the Army, extracting what we needed and selling them back to us to sell back to the Army.”

“So was he a crook or was he providing a valuable service?” I asked. But Veronica had hurried off into the sunset.

.....

I saw Veronica about 6 months later at the Asset Management Conference.

“All running smoothly in Perth?” I asked.

“You’ll like this one” she said. “I went to the electrical distribution branch’s store to review their stock control procedures. As I arrived a truck pulled up with a couple of technicians in it. The storeman asked what they wanted and then directed them out the back to an open concrete area.”—“Probably over on the far left,” he shouted.

“They had come to look for replacement connectors for one of the older lines. I asked the storeman if they were easy to get.”

“Impossible,” he said. “They stopped making them 10 years ago, but some of the ones on the old wires are still usable. We never throw anything out.”

“Do you have records of what you’ve got?” I asked.

“Naw-ugh,” he said

“I thinking he was expressing a certain contempt for office wallahs.”

“Well they had one thing right,” I said, “The storeman knew the business.”

20.27 Exercises

20.27.1 Self-Assessment Exercise 20.1

1. What are the aims of inventory management?
2. How are spare parts normally identified?
3. What is meant by:
 - a. Dependent Demand
 - b. Independent Demand
4. What is meant by:
 - a. Current Stock Level
 - b. Dues In
 - c. Dues Out
 - d. Net Level
 - e. Back Order

20.27.2 Self-Assessment Exercise 20.2

1. What is meant by:
 - a. Reorder Level and MIN
 - b. Reorder Quantity
 - c. MAX
 - d. Lead Time
 - e. Safety Stock
 - f. Service Level
2. What factors influence stock holding policy for a slow moving item?

3. Explain the terms:
 - a. Issue Multiple
 - b. Shelf Life
 - c. Supply Multiple
4. What is a target level reorder policy?

20.27.3 Reorder Level Exercise

Set a Reorder Level for each of the following items:

1. Item AB1234
 Average demand = 4.36 units/month
 Average lead time = 2 months
 Not critical (Answer 9)
2. Item SL456
 Average demand = 0.78 per month
 Average lead time = 14 days
 Critical (Answer 2)
3. Item C956-12
 Average demand = 12 per month
 Average lead time = 45 days
 Critical (Answer 23).

20.27.4 Reorder Quantity Exercise

Set a Reorder Quantity for each of the following items:

1. Item AQS90-78965
 Demand = 10 per month
 Supplied in boxes of 25 (Answer 25)
2. Item WSX567-321R
 Demand = 2 per month
 Option of individual purchase or in multiples of 50 at a discount (Answer 4).

20.27.5 Actual Order Decisions Exercises

20.27.5.1 Actual Reorder Decision 1

A stock controller has the following information regarding an item. What should he do?

Stock on Hand = 4
 MIN = 8

$$\text{MAX} = 28$$

$$\text{Supply Multiple} = 5$$

$$\text{Dues In} = 20$$

$$\text{Dues Out} = 7$$

$$\text{Special Demand} = 6$$

What would you do?

Solution

$$\begin{aligned} \text{Net Level} &= \text{Stock} + \text{Dues In} - (\text{Dues Out} + \text{Special Demand}) \\ &= 4 + 20 - (7 + 6) \\ &= 11 \end{aligned}$$

This is greater than MIN so no action is needed.

Four items should be issued immediately to cover part of the dues out.

The Dues In should be expedited as there is a shortage right now.

20.27.5.2 Actual Reorder Decision Exercise 2

A stock controller has the following information regarding an item. What should he do?

$$\text{Stock on Hand} = 0$$

$$\text{MIN} = 6$$

$$\text{MAX} = 16$$

$$\text{Supply Multiple} = 5$$

$$\text{Dues In} = 0$$

$$\text{Dues Out} = 8$$

$$\text{Special Demand} = 0$$

What action should you take?

Solution

$$\begin{aligned} \text{Net Level} &= \text{Stock} + \text{Dues In} - (\text{Dues Out} + \text{Special Demand}) \\ &= 0 + 0 - (8 + 0) = -8 \end{aligned}$$

This is less than MIN so an order is needed.

$$\text{Actual Order Qty} = \text{MAX} - (-8) = 24$$

Round to 25.

Order 25.

20.27.6 Self-Assessment Exercise 20.1 Solution

1. *What are the aims of inventory management?*

The primary aim of inventory management in the field of spares and consumables is to enable the meeting of requirements for equipment availability at minimum overall cost. This will involve:

- Keeping service to the users at a reasonably high level
- Keeping inventory investment reasonably low
- Cost-effective purchasing.

A balance must be struck between these conflicting factors.

More basic aims of inventory management are to ensure that:

- Stock identity, quantity and location are known;
- Stock is secure;
- Items are available and accessible when required;
- Purchase orders are placed promptly;
- Goods are received efficiently and effectively.

2. *How are spare parts normally identified?*

Parts will be identified by means of a part number within the organization's inventory management system. The computer record will normally also contain the identification of the manufacturer and the manufacturer's part number.

3. *What is meant by*

a. *Dependent Demand*

Dependent demand is demand which can be estimated or planned, by time and quantity, from a production plan or a scheduled maintenance plan.

b. *Independent Demand*

Independent demand items are items for which demands occur on a variable basis, such as spare parts required for breakdown repairs.

4. *What is meant by*

a. *Current Stock Level* The number of items physically in stock.

b. *Dues In* Items ordered from a supplier but not yet delivered.

c. *Dues Out* Items demanded by a user, but not yet issued.

d. *Net Level* = Current Stock Level + Dues In – Dues Out.

e. *Back Order* An item is on *backorder* or *backlogged* if it is not in stock, has already been ordered from a supplier, but the order has not yet been received.

20.27.7 Self-Assessment Exercise 20.2 Solution

1. *What is meant by*

a. *Reorder Level and MIN*

The reorder level or MIN is a value such that an order is placed when the net stock level falls below it.

b. *Reorder Quantity*

The reorder quantity is the guideline quantity to be ordered. This is typically a convenient handling quantity of 1–3 months demand, with possible consideration of quantity discounts.

c. *Max*

MAX is a guideline for the maximum amount of stock to be held. In practice it can be used as a reorder quantity guideline or as a target level. Typically set to a convenient handling quantity of 1–3 months demand with possible consideration of quantity discounts.

d. *Lead Time*

Lead time is the time taken from when the net level falls below the reorder level until the item becomes available for issue.

e. *Safety Stock*

The expected level of stock remaining at the end of the lead time is known as safety stock.

f. *Service Level*

The service level is the proportion of items supplied at the time required.

2. *What factors influence stock holding policy for a slow moving item?*

- a. Demand Rate.
- b. Item Cost.
- c. Shortage cost/Criticality.
- d. Lead Time.
- e. Safety and Environment.

3. *Explain the terms*

a. *Issue Multiple*

Items are issued in multiple quantities, for example spark plugs. The multiple may be different for different applications, e.g., four- or six-cylinder engine.

b. *Shelf Life*

The time for which an item can be stored before it deteriorates.

c. *Supply Multiple*

Supply is in quantity multiples which are convenient for packaging or transportation.

4. *What is a target level reorder policy?*

In a target level policy, if at the time of ordering, the net level is below a set target level then sufficient is ordered to bring it up to the target level.

Chapter 21

Reliability, Availability, and Maintainability

Abstract To introduce key elements of reliability, availability, and maintainability (RAM) from an asset management perspective. *Outcomes* After reading this chapter you will be aware of the need to specify and check for RAM requirements for asset acquisitions and developments. You will learn about how RAM are measured, and about the factors that lead to successful management of assets in regard to RAM considerations. You will be aware of a number of specific techniques which assist with these tasks.

21.1 Introduction

The topics of Reliability, Availability, and Maintainability (RAM) are important areas of competence for asset managers.¹ As these fields have significant technical depth, a range of levels of expertise can be expected within an asset management group. In a technically specialized organization, there may be a dedicated section specializing in Reliability Engineering and related topics.

In this chapter, the main concepts and techniques will be introduced but they will not be treated in a numerical way. This material is particularly applicable for more technically sophisticated assets.

21.2 Reliability

Reliability is the ability of an item to perform a required function under stated conditions for a specified period of time.² Reliability is important because failures reduce the effectiveness of service and undermine the organizational objectives which the

¹ ISO 55002 Clause 6.2.1.3 Asset management objectives. "... issues ... addressed include ... asset system availability ... reliability ... condition ... life expectancy ...".

² Dictionary of Military and Associated Terms. US Department of Defense 2005.

assets are intended to support. Failures may also have safety and environmental implications. The cost of failure is generally disproportionately high when considered against the costs of sound maintenance, repair, and replacement policies.

21.3 Specification and Testing³

The specification of an asset should include consideration of RAM. At the acquisition planning stage we carry out tests of prospective equipment to check whether the RAM specifications are met. Performance and RAM characteristics must be also checked prior to specific equipment acceptance. Otherwise, the equipment may fail to deliver a reasonable level of service.

The specifications for RAM, will be based on technical input and judgement from knowledge of the type of equipment concerned and the service conditions and requirements involved. The tests will involve operating the equipment for a trial period during which equipment performance, faults, failures, and maintenance activities are recorded and analyzed. The results should then be compared with the required specifications, and may be used to compare competing equipment. Faults may be reduced and performance improved as trials proceed, but finally a judgement is made as to whether the equipment is satisfactory in relation to the specifications, and meets criteria for quality and safety.

Trials also provide information regarding logistic support requirements including maintenance and replacement policies and spare parts planning. It is important to make data-supported decisions on all these topics wherever possible.

21.3.1 Mean Time Between Failures

The most commonly used measure of reliability is the Mean Time Between Failures or MTBF. This is defined as follows:

Mean Time Between Failures (MTBF) is the average time for which an equipment operates between failures occurring.

21.3.2 Failure Rate

The *failure rate* is the number of failures per unit of operating time.

³ ISO 55001 Clause 10.2 Preventive action: “The organization shall establish processes to ... identify potential failures ...”.

21.3.3 Failure

A *failure* is a deterioration of an item such that it is no longer able to perform its required function. However, some failures may have only a minor impact on equipment operation. Care must be taken in deciding what constitutes a failure in any analysis or in any form of reliability trial.

21.4 Design for Reliability⁴

The design of equipment should reflect the level of reliability required by the application specification. At the design phase, techniques such as Failure Mode and Effects Analysis (FMEA) are applied to assess how an item may fail and to subsequently reduce the risk of failure. Besides the design of the equipment itself, the reliability of a system is influenced by the degree of *redundancy*. In systems where high reliability is required, this is often achieved by having components, assemblies, or units working in parallel, or on standby, so that if one item fails the system remains operational.

21.5 Managing the Reliability of In-service Assets

Beyond the initial acquisition stage, where reliability will depend largely on design factors, reliability should be managed throughout the life of an asset. Many techniques have been devised to assist in this process and some of these are outlined in this section. Figure 21.1 gives a flowchart relating to the management and improvement of reliability. The techniques named will be considered in this chapter. Full details are given in books dedicated to reliability, such as O'Connor.⁵

21.5.1 Operator Records and Incident Reports

Operator logs or records form a useful source of information about equipment performance and condition. The frequency and extent of delays, losses, or faults can be determined directly and in a timely manner from these logs. Following up

⁴ Stapelberg, R.F., Handbook of Reliability, Availability, Maintainability and Safety in Engineering Design. Springer 2009.

⁵ O'Connor, Patrick D. T., "Practical Reliability Engineering", 4th ed., John Wiley & Sons, 2002.

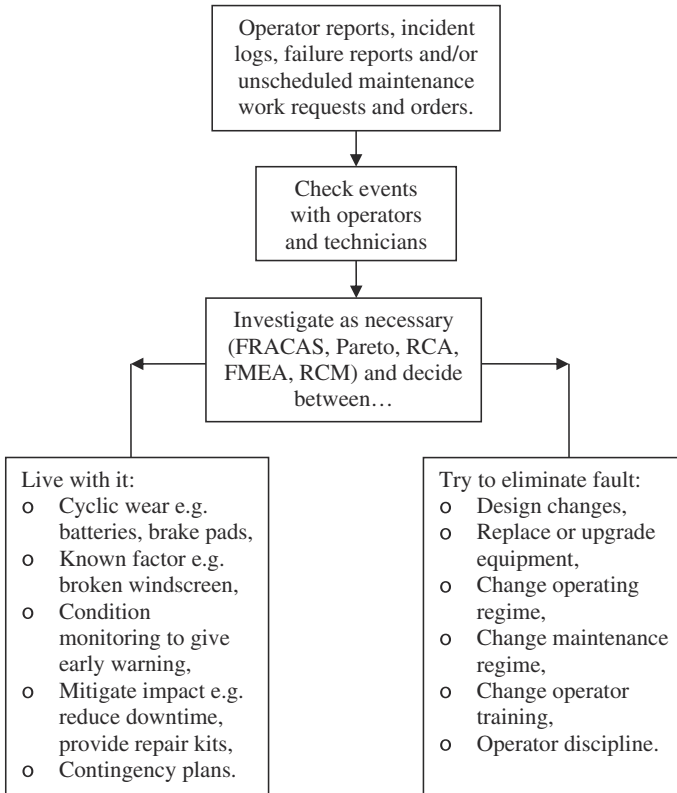

Fig. 21.1 In-service reliability management

on the data from operator logs can lead to the determination of causes of problems and to action to eliminate or mitigate problems. Data from work requests and work orders are also valuable and form the normal basis for failure investigation, but operator logs are relatively neglected as a source of useful information for reliability improvement.

21.5.2 *Toolbox Meetings*

A toolbox meeting is a meeting of maintenance personnel with supervisors and planners, typically held weekly as part of the maintenance planning and scheduling process. Feedback from maintainers forms a valuable source of information relating to in-service asset reliability.

21.5.3 Management Reaction

The key step here is for management to listen to the feedback and to take corresponding action where warranted. The reporting and management of incidents forms a basis for managing the performance and reliability of assets. There is a saying that 30 incidents become one accident and 30 accidents become one fatal accident. The causes of losses and incidents should be investigated and steps taken to prevent future occurrence and to mitigate the consequences.

Some specific pointers are as follows:

- Staff to be given time, encouragement, and processes to record incidents, errors, mistakes, faults, problems, defects, and failures;
- Retaining defective or broken parts and materials, e.g., in a tray or bucket, taking photos including close-ups, making written records, refer FRACAS and Root cause Analysis (RCA) techniques;
- Problems to be resolved or referred upward. Meetings to be arranged with shop floor personnel to allow time for reporting and discussion;
- Technical support to be available to assess incidents, provide feedback and take suitable action as appropriate;
- Do not just fix it, improve it so that it does not fail again;
- Bad news to be passed on as first priority;
- Systematically retain plant knowledge;
- Systematically disseminate plant knowledge;
- Minority opinions to be aired—suffer fools gladly, they may be right;
- Innovation and automation to be treated with caution.

21.6 Failure Patterns and Causes

Reliability analysis involves an understanding of patterns and causes which commonly arise in relation to equipment failures. There are three common failure rate patterns:

- Burn-in or early life or infant mortality failures;
- Random failures, the term random meaning “not age related” in this context;
- Wearout;

An example of these failure rate patterns is given in Fig. 21.2 which shows the mortality rate of humans, with phases of infant mortality, a middle age range with little variation in the mortality rate and finally, significantly increasing mortality rates with age. The shape of this graph gives rise to the term “bath tub” curve.

Determining the relevant pattern or patterns of failure for any particular asset, or for any particular failure mode of an asset, may require statistical analysis. Statistical analysis is outside the scope of this book, but some examples of the use of failure patterns are now discussed.

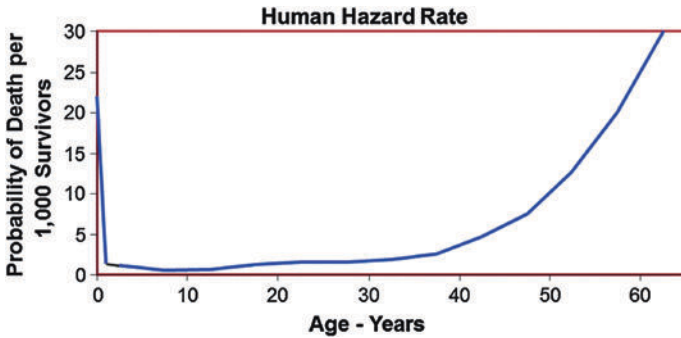

Fig. 21.2 The pattern of human mortality

21.7 Failure Pattern Discussion

21.7.1 Useful Life

The useful life of an asset is the period where its reliability is high and the risk of failure is low. Asset reliability can be relatively poor in the burn-in and wearout phases. This means that we need to avoid the burn-in and wearout phases, and ensure that random failures are kept to low levels. In general, we should investigate failures of any type to determine the root cause and take steps to avoid repetition.

The types of failure patterns are summarized in Fig. 21.3, which also indicates the types of causes. Not every item exhibits every pattern. If items are well manufactured with good quality control, burn-in failures can be minimized. Also, components should ideally be designed to last as long as, or longer than, the parent equipment, so that they do not reach the wearout stage. Thus many items will not reach wearout, particularly if they suffer little or no physical stress. Electronic items are typically in this category.

Burn In	Manufacture defect or faulty installation. Infant mortality. Occurs early in life. Rate decreases as early faults eliminated.
Random	Not related to item age or service time , so rate approximately constant through time. Often an external cause. Can also be failure of a complex system with many failure modes, such as electronic systems.
Wearout	Rate is related to and increases with age or service life. Causes include wear, ageing, corrosion, fatigue, creep, embrittlement of plastics.

Fig. 21.3 Age or operating life and failure rate patterns

21.7.2 Burn-in Failures

Burn-in failures are failures which occur early in the life of an asset, usually related to some form of manufacture or installation defect.

An example is a case where gearboxes on heavy haul trains were failing prematurely. At first the cause was unknown, but an investigation revealed that some of the gearboxes had fretting (wear patterns caused by frequent small movements) of the bearings. This was traced to the fact that these gearboxes had been transported by sea without the moving parts being secured. The fretting initiated serious wear when the gearboxes were put into service. The problem was tackled by ensuring that all the moving parts were secured before the gearboxes were transported from the manufacturer to the user.

Burn-in failures can be minimized by choosing well-developed and well-manufactured equipment and paying attention to acceptance testing and installation. Stress screening of electronic components and assemblies is a technique used to eliminate manufacture defects.

21.7.3 Random Failure Examples

Random failures are failures which occur as a result of events which are not related to the age or service life of the asset. They usually have an external cause.

An example is in a sugar refinery where sugar is filtered through a cloth. Failure of the cloth occurs when holes appear and it then has to be replaced. This may seem at first to be a wearout phenomenon, but examination showed that the failures of the cloth only occurred as a result of random inclusions of foreign matter in the raw sugar and were not related to the service time of the cloth.

In a manufacturing process, finned tube is made using an extrusion tool. Tools are found to break after making varying lengths of tube. The average length of tube per tool is 39 m. The operators suggest changing the tools just before this average length is reached. However, statistical analysis showed that the failure rate of the tools did not vary with the length extruded. Subsequent metallurgical analysis shows that breakage is due to random imperfections in the tube material and not to wear of the tools.

Reliability in the random failure phase can be enhanced by measures such as:

- Operate the equipment responsibly
- Do not overload
- Keep everything neat, clean, and tidy
- Do not leave stuff blowing in the wind
- Keep up-to-date with all preventive maintenance
- Fix minor faults or degradations promptly.

21.7.4 Wearout

Wearout failures are failures which arise due to age- or service-related deterioration. There are many examples of wearout failure modes. Common ones are the wear of vehicle tyres and brake pads. Other examples are the degradation of lubricants with time and use; corrosion of steel structures; fatigue of railway tracks or of any component subjected to repeated stress cycles.

Assets should be retired (or refurbished) at the onset of wearout. This means that we need to take measures to determine when wearout commences. In many cases, this can be done by an inspection or condition monitoring process. If so, we should use these techniques to determine a condition-based repair or replacement policy.

21.7.4.1 Statistical Analysis and Age Exploration

In some situations where parts cannot be effectively or economically monitored, we need to undertake statistical analysis or age exploration in order to determine an appropriate repair or replacement policy. This can occur when parts are not readily accessible, and particularly with failure modes such as:

- fatigue
- corrosion
- erosion
- insulation loss
- brittle decay of plastics.

Statistical analysis involves recording the age or operating life to which items run with and without failure and using techniques such as Weibull analysis⁶ to estimate the point at which a rise in the failure rate becomes significant.

Age exploration involves running items to a gradually increasing age under controlled circumstances. If we do not want any in-service wearout failures—as for example with an airframe—the age exploration can be carried out under controlled laboratory conditions. Otherwise, we may have a selected population run under low-risk circumstances to act as the age exploration group.

21.7.5 Failure Mode Relative Importance

Studies of failure mode frequencies have highlighted the fact that straight counts of reported failures show larger numbers of random or burn-in failures than of

⁶ P.D.T. O'Connor. Practical Reliability Engineering, ISBN: 0 470 84463 9.

wearout failures. However, the number of failures of a particular pattern does not necessarily reflect the importance of those failure modes. In aircraft, for example, wearout failure patterns of engine or structural components, are of much greater importance than the failure of electronic components for which duplicate systems exist. Our view of the importance of failure modes needs to take into account the consequences of failure.

21.7.6 Failure Interdependency

An additional factor to be considered in relation to reliability is that failures are not necessarily independent of one another. We can identify the following types of interdependencies.

- Independent—physically and statistically, e.g., individual light globes.
- Cascade—failure of one item triggers failure of others. Example, in Auckland, New Zealand, a power cable serving the central business district failed. Failure of one cable then caused an overload on others leading to further failures and a loss of all power to the district.
- Secondary damage—failure of one item impacts others, e.g., failure of wheel bearing results in damage to suspension and steering mechanism.
- Dependent—Power supply failure affects both an operating pump and the standby pump.
- Interrelated—Failure or degradation of one component causes another to wear more rapidly, e.g., seal failure admits sand to bearing causing wear.

21.7.6.1 Example

In 2008, a pipeline bringing gas from under the sea at Varanus Island in Western Australia ruptured and the gas ignited. The heat from the fire caused three other adjacent pipelines to rupture and extended the fire, which took 2 days to put out. Western Australia's gas supplies were cut by about 30 % for several months. Investigations showed that there was no corrosion coating on the pipeline on either side of the rupture point (Engineers Australia, November 2008).

21.7.7 Bad Actor

A bad actor is an item which fails between turnarounds. Identify and try to eliminate bad actors.

21.8 Failure Reporting and Corrective Action System (FRACAS)^{7,8}

FRACAS is a formal system in which a range of specified parameters are reported when a failure occurs, and a specified systematic approach to corrective action is taken. US-MIL-STD-781 provides a description of FRACAS including details of the type of report to be generated when a failure occurs. Factors to be included in the report are:

- Failure/incident title
- Name of person raising the report
- Date and time of occurrence
- Equipment type
- Site and location of occurrence
- Contingency action taken
- Equipment odometer reading at failure
- Description of failure
- Description of effect of failure
- Repair action taken
- Operating conditions
- Cause of failure
- Date report raised
- Report of investigation
- Recommended actions to correct
- Follow-up testing or verification whether actions are effective
- Losses, time, cost
- Effects on safety
- Effects on environment
- Effects on production

Nonroutine work orders should always be examined as a basis for cause analysis and for determining actions to correct faults. This will typically involve understanding the equipment and possibly making changes, e.g., reduce overloading, design changes, and maintenance changes. There should be follow-up testing or verification to assess whether actions are effective.

⁷ US-MIL-STD-781.

⁸ ISO 55001 Clause 10.1 Non-conformity and corrective action: “When a nonconformity or incident occurs ... the organization shall ... react ... take action ... review ... make changes if necessary ...”.

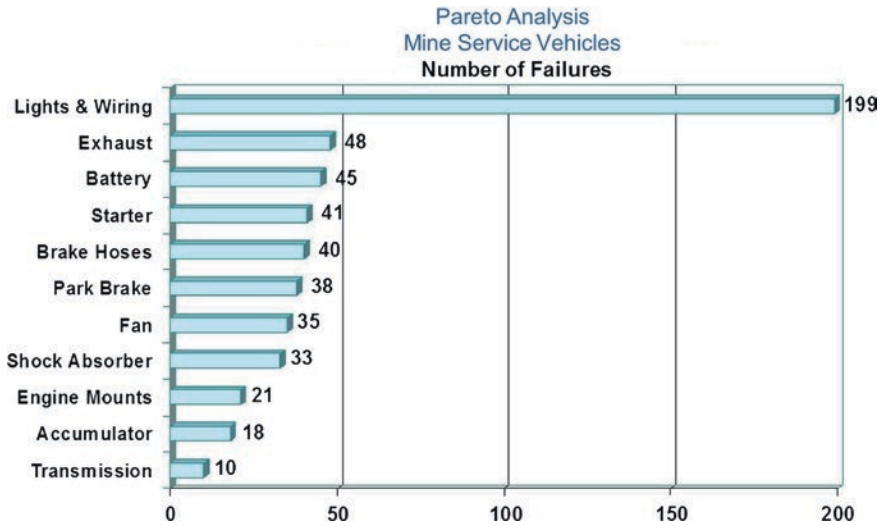

Fig. 21.4 Pareto analysis of mine service vehicle failures

21.9 Pareto Analysis

Pareto analysis, as applied to equipment failures, means ranking failure modes by frequency and cost. The most frequent and highest cost failure modes can then be addressed. Figure 21.4 is an example of frequency ranking.

In this application, the frequent problems with lights and wiring were reduced by replacing metal filament lights with LED lights which did not completely fail on impact, allowing the vehicle to continue in use until a convenient repair opportunity. Driving discipline was also addressed, as was road condition.

21.10 Failure Mode and Effects Analysis^{9,10}

FMEA also known as *Failure Mode, Effects and Criticality Analysis* (FMECA) is a procedure used in assessing all the potential ways in which a product may fail, assessing the causes and effects of failure, and carrying out a numerical risk ranking. The technique is used in the design or manufacture of products. Recommendations to correct the failures or mitigate the effects are then made and acted upon. This technique can also be used in the investigation and correction of in-service faults and failures.

⁹ IEC 60812 Failure Mode and Effects Analysis.

¹⁰ ISO 55001 Clause 10.2 Preventive action: “The organization shall establish processes to ... identify potential failures ...”.

21.10.1 Common Failure Modes and Mechanisms

Examples of failure modes are given in Table 21.1.

21.11 Root Cause Analysis (RCA)¹¹

Nullius in verba (Take nothing for granted). Motto of the Royal Society of London (1660).

RCA also known as Root Cause Failure Analysis (RCFA) is a formal approach to determining the cause of failures, with the intention of preventing future occurrences. The investigation of failures should be an organized activity involving personnel trained in investigative techniques and local operators and maintainers. There is some overlap between the concepts of Failure Recording and Corrective Action (FRACAS) and RCA. RCA is normally applicable to failures which require a degree of in-depth investigation.

When a failure occurs the following actions should be taken:

- Record the incident or ongoing problem.
- Take action to manage the issue in the short term.
- Assess the level of response needed—does the effect justify a substantial investment of time, effort, and money.
- A suitably skilled person should attend the site promptly.
- Preserve evidence, particularly broken parts.
- Record witness statements on site and in surrounding areas.
- Document observations, take photographs.
- Collect data and information systematically.
- Form an investigation team with specific roles and responsibilities.
- Develop hypotheses and test with data.
- Prepare a report with findings, conclusions, and recommendations.
- Implement recommendations to prevent or reduce the likelihood of a repeat incident.

In investigating an incident the primary aim is finding out why the failure occurred and in preventing it occurring again. Some useful questions to ask about a failed item are as follows:

- What is it supposed to do?
- Do we really need it?
- How is it supposed to work?

¹¹ Gano, Dean L., *Apollo Root Cause Analysis*. Apollonian Publications, Yakima, Washington, Second Edition 2003. ISBN: 1 883677 01 7.

Table 21.1 Failure modes

Breakage due to wear and tear
Breakage or jamming due to overloading, misapplied load, and excess tightness or looseness
Brittle failure, deterioration of plastic component due to loss of internal lubricating components due to aging and heat
Breakage due to alignment incorrect
Breakage due to out of balance causing vibration
Connection failure electrical
Corrosion, rust
Erosion of pipe or channel from fluid flow
Dirt or foreign matter in mechanism, pipe
Filter blocked or dirty
Foundations not firm or secure
Loose or missing nut, bolt, or fastener
Lubricant lacking, deteriorated or dirty, may cause seizure or overheating
Insulation breakdown
Water in oil
Design or manufacture fault
Fatigue failure
Vibration caused by wind
Vibration caused by rotating parts
Hose perished
Incorrect assembly
Leak in pipe, valve, tap, hose etc.
Loss of hydraulic fluid
Part missing, loose or falls off
Overheating due to lack of coolant, or cooling surface blocked
Seal leaking
Short circuit
Thermal stress causing fracture of pipe, vessel or structure
Welding fault causing fracture of pipe, vessel or fabrication
Drain blocked
Electrical insulation failure
Electrical connection failure
Consumable not replenished, e.g., detergent, disinfectant, lubricant
Catalyst regeneration required
Acid balance incorrect (or other chemical factor)
Vandalism, abuse
Storm damage, lightning strike, high wind
Accident damage
Operator, maintainer lacks knowledge of correct operation
Vermin—e.g., rat chews through insulation, bird makes nest in air inlet, toads block overflow
Power supply failure
Water supply failure

(continued)

Table 21.1 (continued)

Protective device failed
Fire damage
Flood/water damage
Wear
Fretting—repeated small movements caused by vibration, movement of ship, and movement of any supporting item

- If necessary, examine drawings;
- If all else fails, read the instructions;
- Observe a cycle of operations;
- Was it overloaded?
- Was it being misused?
- Was it operating within design parameters?
- Was it broken earlier?
- Has it received required maintenance?
- Is it a known fault?
- Is there a better way?
- Has a design change already been notified?

The extent to which it is desirable to pursue the root cause of a problem can vary. In many cases, it is best not to go to more depth than is necessary to get a solution but solving problems can sometimes lead to significant improvements.

21.11.1 Five Whys

Five Whys is a simple technique of RCA which can be quick and effective. It consists of asking ‘Why’ something happened, and then why the previous thing happened and so on, until an explanation is found. All the answers can be important.

For example: Shipment of iron ore is delayed.

First question: Why was the shipment delayed?

First answer: The stacker-reclaimer was slow in loading the conveyor.

Second question: Why was the stacker-reclaimer slow?

Second answer: Some of the ore was out of position in the stockpile

Third question: Why was some of the ore out of position?

Third answer: The dozer did not position the ore in time.

Fourth question: Why did the dozer not position the ore in time?

Fourth answer: The dozer is too small to cope with the workload.

Fifth question: Why is the dozer too small?

Fifth answer: Because it was not upgraded when the stacker-reclaimer capacity was increased.

The next step is to make a business case for upgrading the dozer.

21.11.2 Action and Condition Causes

To investigate a failure in more depth involves assessing *action causes* and *condition causes*. This can be tackled systematically as follows:

- Assemble knowledgeable team including users and maintainers.
- Identify symptoms of problem.
- Focus team on the specific problem.
- Define problem carefully. Which parts are affected, which are **not** affected.
- Under what conditions does the problem arise. Under what conditions does the problem **not** arise.
- Develop Cause Tree. Use stickers on white board.
- Consider both immediate causes (action causes) and contributory circumstances (condition causes).
- Avoid diverting to broader, unrelated issues.
- Brainstorm obtaining a solution, even if the root cause remains elusive.

21.11.3 Example—Pump Failure

In an underground copper mine, water gathers at the lower levels. For mining to proceed it is necessary to run pumps to clear the water. On a particular occasion, flooding occurred at mine level 23. This resulted in 24 h lost production. Figure 21.5 shows the first cause tree developed in a RCA of this failure. The failure was traced to a failure of pump number 14B. This was the Action Cause of the flooding. The Condition Cause was found to be a high level of mud in the water, which caused damage to the pump impeller, resulting in pump failure.

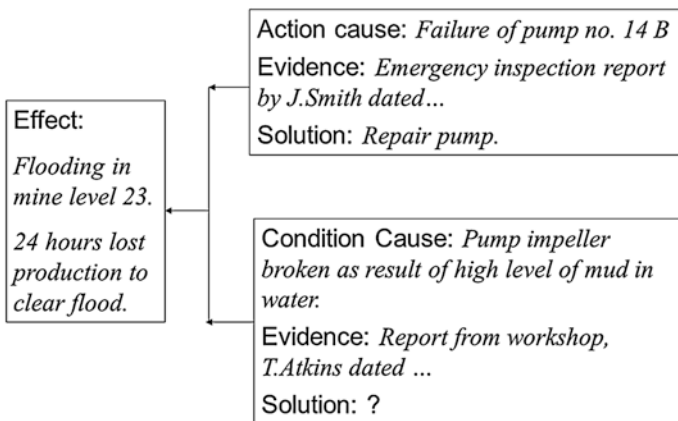

Fig. 21.5 Root cause analysis. Cause tree 1

21.11.4 Brainstorming a Solution

Some things to consider are as follows:

1. *Operation audit* Has it happened before? Evaluate operating procedures and practices. Is operation within design load or range. Consider cleanliness, tidiness, and housekeeping.
2. *Maintenance audit* Evaluate actual maintenance history, lubrication, wear, alignment, balance, maintenance tasks and frequency, ease of access, tools, procedures. Is there a symptom of a deeper problem?
3. *Design audit* Evaluate design standards and rules, capacity, loading, movement, methods, materials, fits and tolerances, design principles, environmental conditions.
4. *Management audit* Is there satisfactory management of operation and maintenance.

21.11.5 Example—Pump Failure Continued

Considering a solution to the pump failure problem, an essential action was to repair the pump. However, although this would solve the immediate problem it did not tackle the root cause. The root cause is shown in Fig. 21.6 as silt build up in the bund at level 14.

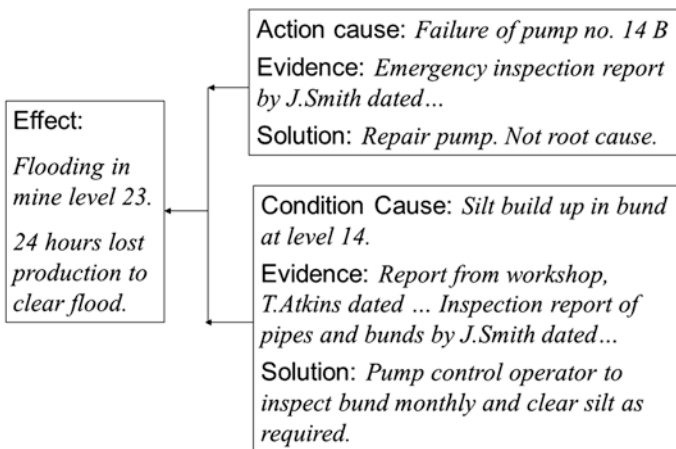

Fig. 21.6 Root cause analysis. Cause tree 2

21.11.6 Actions to Remedy

Task analysis dewatering pump:

- Repair pump
- Standby pump needed?
- Redesign sump to minimize silt?
- Provide small dredge to reduce excess silt when needed?

General case: Formulate improvement plans. Involve the user. May require changes to:

- operations;
- design;
- maintenance;
- equipment replacement;
- Use “fool proofing” (poka yoke) to help minimize errors in operation, set-up or handling.

Assess cost-effectiveness of improvement plans.

- Feed back results to workers—whatever the result may be.

21.12 Condition Monitoring

Condition monitoring involves using a diagnostic technique with the aim of detecting degradation of a function or component before failure occurs, with a view to taking remedial action to prevent in-service failure. Examples of monitoring techniques are the following:

- Vibration analysis
- Oil analysis for lubrication quality and contamination
- Temperature monitoring
- Acoustic (sound) analysis
- Ultrasonic detection for metallurgical weakness
- Insulation testing

Condition monitoring is known as *predictive maintenance* because it attempts to identify situations of impending failure and then to take action in advance so that the failure does not occur. The savings in avoiding in-service failures can be substantial when factors such as reduced unscheduled downtime, reduced labor, reduced parts usage, and reductions in secondary damage are taken into account.

Asset and maintenance managers need to be aware of the condition monitoring techniques which are most appropriate to the assets under their care. An early work which describes many condition monitoring techniques is R.A. Collacott,

Fig. 21.7 Condition monitoring techniques and medical parallels

<u>Machine</u>	<u>Human Being</u>
Human senses	Appearance - looks ill
Vibration analysis	Pulse, ECG
Thermographics	Temperature
Oil analysis	Blood sample
X-rays	X-rays
Ultrasonics	Ultrasonics
Pressure gauge	Blood pressure,
Performance monitoring	Stress test
Borescope	Endoscope
Megger – insulation testing	Angiogram
Strain gauge – movement of buildings or structures	Sprain

“Mechanical Fault Diagnosis”. Over recent years there have been many advances in these techniques, particularly in terms of cheaper and more effective versions of the diagnostic tools. Figure 21.7 shows a list of condition monitoring techniques and the analogous technique used in medical diagnosis.

21.12.1 Delay Time or P-F Interval

An important factor in condition monitoring is that the detection of a degraded state must occur with sufficient time in hand to rectify the situation before in-service failure occurs.

An example is the case of wood rot of power poles. The condition of the poles deteriorates slowly over a period of years and the condition of a pole can be measured in terms of the amount of good wood left at any given stage. There is time to inspect the poles at intervals of several years and to determine which poles will need to be replaced soon.

Considering the general case, Fig. 21.8 illustrates schematically the deterioration in condition of an item from a “No fault” situation to one where a deteriorated condition is detectable. The item is monitored at intervals “I”. The “Delay time” also known as the P-F Interval, (time from Potential to actual Failure) is the time that the fault condition takes to deteriorate into an actual failure. The idea is to set the monitoring interval to no more than half the delay time, so that the fault will be detected as shown in Fig. 21.8, in time for remedial action to be taken and the actual failure avoided.

21.12.2 Condition Monitoring Applicability

Condition monitoring is potentially applicable if the following conditions exist:

- Degradation becomes evident, indicating the existence of a potential failure mode that allows the progress of the failure conditions to be identified.
- Consistent failure patterns allow fault information to be diagnosed accurately.

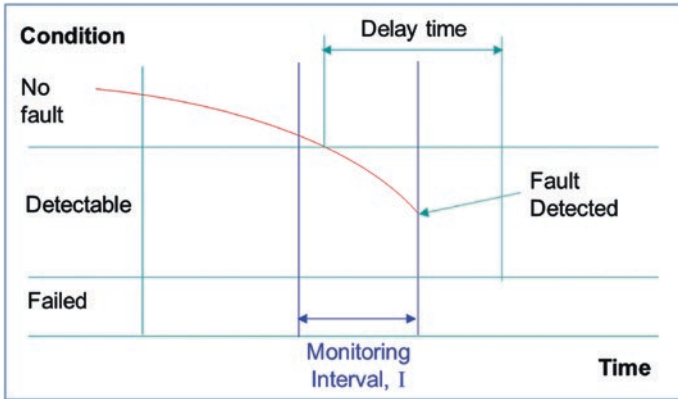

Fig. 21.8 Condition monitoring interval and delay time

- The time interval from the onset of potential failure to total failure (P-F interval or Delay time) is sufficiently long to accommodate the monitoring interval and the time taken for remediation/rectification. The monitoring interval is typically set to less than half of the P-F interval.
- Condition monitoring data can be collected with a high degree of repeatability.

21.12.3 Limitations

Limitations of condition monitoring occur when the time taken for a failure mode to progress from satisfactory operation to failure is short. This can occur with fatigue failures or brittleness of plastics. Another example is oil or grease condition where degradation can be rapid in hot or dusty environments.

21.12.4 Condition Monitoring Effectiveness

The effectiveness of a predictive maintenance technique can be assessed in terms of the reduction in in-service failures that it achieves. If in-service failures are still occurring, then the monitoring technique is of limited effectiveness and may need to be improved or supplemented by other actions such as age or service life-based replacement.

The “high-tech” nature of condition monitoring can lead to an assumption that it is 100 % effective, when in fact the effectiveness may be much lower than this. It is best to record data on the numbers of in-service failures which occur with the regime in place as a check on the effectiveness of the scheme.

Condition monitoring is a diagnostic tool and can have “Type 1” errors where an incipient failure is not detected and “Type 2” errors where a degraded condition

is incorrectly indicated, or the wrong failure mode is diagnosed. For example, vibration analysis may not pinpoint the actual problem but can lead to time wasted in dismantling areas where there is no fault. Condition monitoring is very effective in many situations, provided that we are aware of its possible limitations.

21.12.5 Applications of Condition Monitoring

Some common applications are:

- Vibration monitoring of rotating equipment. Rotating machines when running correctly have moderate levels of vibration at certain frequencies, rather like a human heartbeat. The pattern of vibration is known as the vibration signature. Significant variations from the normal vibration pattern can be detected by instruments and warn that failure is imminent. Action can then be taken to check the machine and avoid a catastrophic failure.
- Thermographic inspection of electrical and mechanical equipment utilizing infrared measuring equipment. This detects variations from normal operating temperatures. For example, this can indicate a poor connection, insulation loss, or an open circuit in the electrical case and overheating of bearings or blockages or leaks in pipes or heat exchangers in a mechanical case.
- Wall thickness testing of piping and pressure vessels. This uses ultrasonic test equipment.
- Lubricant analysis for lubricating properties and impurities.
- Hot circuit fluid analysis.
- Trend analysis of cathodic protection and corrosion probes.

21.13 Reliability Centered Maintenance^{12,13}

Reliability Centered Maintenance (RCM) is a systematic method for establishing a maintenance policy. This technique is suited to situations where an in-depth analysis is required. The application of RCM must involve an appropriate level of engineering authority, consistent with the technology of the application for which the maintenance policy is being developed. At the same time, the value of this technique lies in combining the knowledge of maintenance, engineering, and management staff in a structured process, providing benefits from the in-depth communication involved.

¹² Moubray, John, "Reliability-centered Maintenance", Industrial Press, New York.

¹³ IEC 60300 3 11 Reliability Centered Maintenance.

Fig. 21.9 Reliability centered maintenance concept

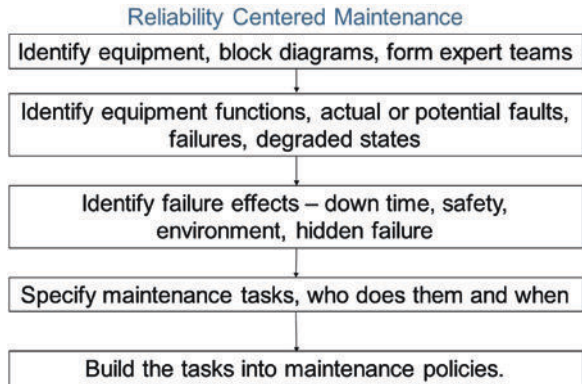

RCM provides a logical link between the equipment function, the need for reliability and safety, and the related maintenance policy. Figure 21.9 illustrates this.

21.13.1 Information Sources

Sources of information used in RCM include:

- Manufacturers documentation;
- Experienced maintenance personnel, particularly older staff, planners and supervisors;
- Records of previous maintenance activities;
- Maintenance and technical support staff;
- Suppliers;
- Consultants;
- Experienced operators;
- Operations records;
- Manufacturers local representative;
- Other users of same equipment;
- Statutory requirements; and
- Engineering standards and published guidelines.

21.13.2 Guidelines

- Select equipment to be analyzed.
- Form an “expert team” consisting of maintenance technicians, planners, supervisors, and engineers to carry out the RCM activity. A facilitator familiar with the RCM process will be needed.

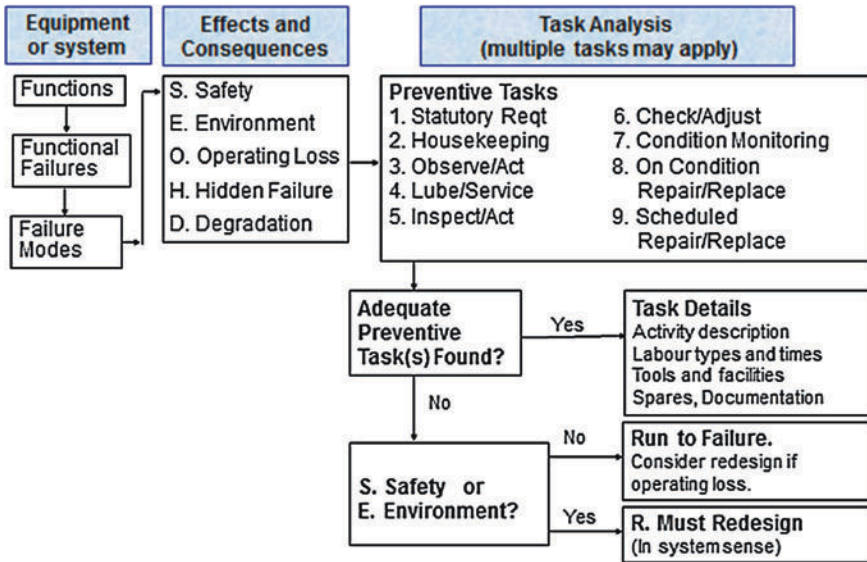

Fig. 21.10 Reliability centered maintenance flowchart

- Participation by the technicians is essential to achieve the “buy-in” necessary for successful implementation of the results.
- Take a fresh view, but be aware of existing maintenance plans and accept them as part of the RCM process where reasonable.
- Have an agreed format for the result using standard forms.
- Create and implement complete results in moderate-sized chunks.
- Do not go beyond the level of detail or design that your organization will handle.
- Consider the resources required to carry out each task as it is created, both at the task level and at an aggregate level.

The flow chart in Fig. 21.10 summarizes the RCM procedure.

21.13.3 Function and Functional Failure

A “function” of a machine or component is anything which it is supposed to do.

For example, the function of a brake is to slow and stop something. The function should include relevant technical values, e.g., a brake should stop a vehicle with specified load and speed within a specified distance. Understanding the function of a component is the key to understanding the reason for maintaining it correctly.

A “functional failure” is failure to perform a required function. This may not mean that an item fails in a complete physical sense.

In deciding the functions of an item, consider:

Basic role of the system, assembly or component, e.g., to provide power (engine), to transmit power (transmission), to hold vehicle in stationary position (hand brake).

Technical values associated with the function, e.g., engine to provide up to 150 kW of power, handbrake to hold vehicle on 1 in 4 gradient when vehicle loaded to 2 tonnes gross.

Efficiency/economy of function, e.g., fuel consumption not greater than 10 l per 100 km.

Structural integrity,

Environmental integrity,

Appearance and comfort,

Control,

Safety,

Whether there are **required** functions that are **not** provided, and

Whether there are **redundant** functions.

21.13.4 Functional Failure

A “functional failure” is failure to provide a required function.

Example: A pump in a given application is needed to pump water at 1,000 l/min. If the performance of the pump has deteriorated to the point where it can no longer deliver water at this rate, then the pump has a functional failure.

The pump may be working in a technical sense but it is failing to provide the required function. Of course it is also a “functional failure” if the pump fails completely.

21.13.5 Failure Mode

For each function of the selected item, we consider how it might or does **fail**.

We also identify all minor **faults**, undesirable conditions or degraded states, which may eventually progress into actual failures, for example:

- low oil level
- loose drive belt
- worn brush on electric motor
- leaking pipe.

21.13.6 Effects

For each failure or fault mode, we next consider the potential effects. The logic check sheet indicates five types of effects which must be considered:

- Safety
- Environment
- Operating or Production Loss
- Hidden Failures
- Degradation.

21.13.7 Hidden Failures

Hidden failures are failures which are not readily apparent to the operator of the equipment. Typically, they occur in protective devices. For example, if a burglar alarm fails, it will not be apparent, unless the alarm is tested, or a burglary occurs.

To check for a hidden failure it will be necessary to carry out an inspection or test of some kind.

21.13.8 Tasks

The next step in RCM is to determine maintenance tasks or actions which address the situation created by the failure modes and effects. RCM requires a review of all tasks to ensure that all the effects identified for a failure mode are met. The review of tasks may lead to the introduction of, or adjustments to such aspects as,

- inspection intervals,
- lubrication intervals,
- checks and adjustments,
- component or equipment replacement intervals or guidelines,
- condition monitoring regimes,
- repair pools and rotables provision,
- repair kits,
- check lists,
- troubleshooting guides,
- accessibility,
- tools,
- spare parts optimization,
- field repair teams provisioning,
- workshop facilities provisioning,
- redesign, and
- level of repair policy (Fig. 21.11).

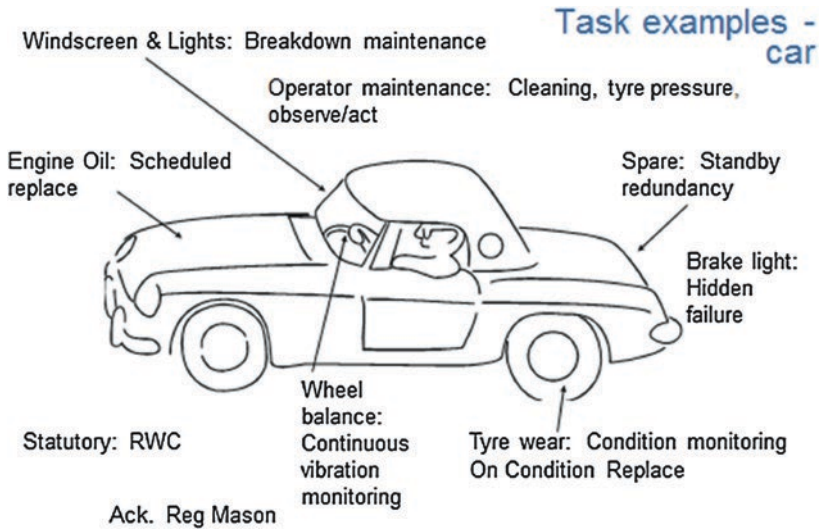

Fig. 21.11 Vehicle maintenance tasks

21.13.9 Reliability Centered Maintenance Conclusion

In conclusion, we see that RCM provides a systematic method for establishing a maintenance policy. The value of the technique lies in combining the knowledge of maintenance, engineering, and management staff in a structured process, providing benefits from the in-depth communication involved. RCM provides a logical link between the equipment function, the need for reliability and safety and the related maintenance policy.

21.14 Maintenance Policy Review

Most organizations already have maintenance policies in place. Maintenance Policy Review is a procedure for checking the suitability of the existing maintenance tasks. It is also known as Preventive Maintenance Optimization, or Reverse RCM. An RCM-style analysis is created, with the existing maintenance tasks being taken as a starting point and then considering the failure modes they are intended to address. This particularly includes inspection tasks. The analysis considers:

- the existing maintenance tasks,
- the range of failure modes that particular tasks are addressing,
- how effective is each task,
- are some tasks redundant,
- is there is duplication or overlapping of tasks,
- are there ways of combining tasks to reduce duplication or frequency,

- are other tasks needed, and
- can improvements be made to the effectiveness of remaining tasks.

There is a tendency for maintenance tasks to multiply over time in response to particular failures or incidents and this can result in overmaintenance. Maintenance Policy Review can offset this trend. It is important that the basic logic of normal RCM is respected, particularly in regard to safety considerations.

21.14.1 Example

At a minerals processing site, material is handled by crushers, conveyer belts, screens, and mills. A Maintenance Policy Review finds that several different groups (operators, mechanics, electricians, and condition monitoring technicians) are carrying out overlapping inspection processes. A rationalization of these processes produces considerable savings. The role of the operators is extended through additional training and the provision of basic monitoring equipment and time is freed up for the technicians to handle higher level work.

21.15 Availability

Availability is the proportion of time for which a machine is available for use. The simplest concept of availability applies when we have a single machine which is required continuously and which has an associated repair crew. The state of the machine is either “Up,” that is running or available to run, or “Down,” that is, failed. When the machine fails the repair crew repairs it. Figure 21.12 illustrates the situation. Availability of the machine is defined in the following terms.

Availability is the proportion of time for which a machine is available for use.

Down Time is time when equipment is not operable.

Up Time is time for which equipment is operable.

$$\text{Availability} = \text{Up Time} / (\text{Up Time} + \text{Down Time}) = \text{Up Time} / \text{Total Time}$$

Fig. 21.12 Availability

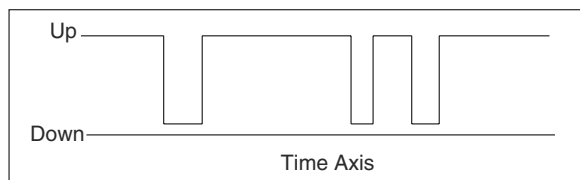

Given the mean time between failures MTBF of the machine and the mean time to repair MTTR, then the Availability, A, is given by:

$$A = \frac{MTBF}{MTBF + MTTR}$$

To achieve a high availability, the MTTR must be much shorter than the MTBF. Availability can be improved by increasing the MTBF or decreasing the MTTR.

21.15.1 System Availability

Most practical situations are more complex than the single machine case. Also, the time taken to get a failed machine running is not just the active repair time, but can include many elements, such as those in Fig. 21.13. Thus, in estimating availability, we may need to consider the Mean Administrative and Logistic Delay Time rather

Element of Down Time	Down Time Reduction Activities
Diagnostic delays	Improved operator training. Improved instrumentation.
Reporting delays.	Improved communications.
Travel time for maintenance person to breakdown location.	Improved transport. Repair person located nearer to breakdown location.
Travel time for machine to repair facility.	Better transport arrangements.
Inspection, diagnosis, repair cost estimating and documentation.	Staffing, equipment, training, documentation, troubleshooting techniques.
Repair decision.	Delegation of authority. Speed of response.
Hazard analysis. Obtaining permit to work	Hazards documented. Good liaison between production and maintenance.
Awaiting spares.	Inventory control. Resupply and purchasing policy.
Awaiting labour. Awaiting repair facilities, tooling, technical information.	Vary staffing by trade, shift, sub-contract, training, multi-skilling. Reassign jobs to another maintenance area.
Active repair time.	Improve maintainability. Study repair methods and procedures, equipment.
Inspection and testing.	Staffing, instrumentation.
Travel to required location.	Transport arrangements.
Installation time. Run up time.	Staffing, training, multi-skilling, methods, procedures.

Fig. 21.13 Elements of downtime

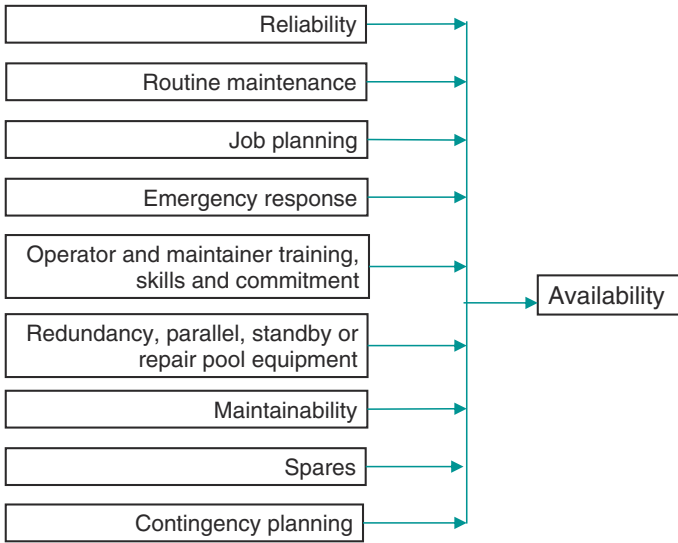

Fig. 21.14 Inputs to availability

than the Mean Time To Repair. Besides these specific types of delay, general factors which contribute to the achievement of availability are shown in Fig. 21.14.

21.15.2 Cost of Downtime

The potential types of cost associated with failure are indicated in Fig. 6.1. The cost of failure and of downtime is the basic driver for maintenance and influences priorities for maintenance. The cost of downtime is hard to quantify, and varies considerably with circumstances, but awareness of the cost of downtime is important to good management, because it provides a sound basis for evaluating the trade-off between maintenance costs, capital equipment expenditure, and business profitability. If managers are not aware of the cost of downtime, they may see maintenance as purely a cost element which can be cut without regard to flow on effects.

21.15.3 Availability When Needed

Many systems do not require 100 % availability all of the time. Preventive maintenance can be scheduled to take place in times of low demand. Breakdown maintenance can continue in low demand periods, such as weekends or holidays. Repair

support can be increased in periods of high demand so as to minimize the effects of outages.

For example, in electricity generation, demand fluctuates with time of day and season of year. Capacity required can be forecast, and individual generators brought on stream at particular times. Equipment shutdowns are scheduled for periods of low demand. Available capacity is normally designed to cover the unexpected loss of the largest generator currently running. Similar considerations apply in transmission systems. This approach is known as $n - 1$ *redundancy*, indicating that the loss of one component should not cause a loss of supply.

21.16 Availability Related to Total Time

Most equipment does not operate on a 24 h 7 days a week basis, and there are scheduled times of nonuse, scheduled maintenance times, and other times when machinery is not required. The definition of availability in these circumstances requires a consideration of how the total time available is partitioned. Figure 21.15 illustrates this.

The following availability measures can then be defined.

$$\begin{aligned}
 \text{Availability (When Required)} &= 1 - M3/(SP - NR) \\
 &\text{(of equipment from maintenance when required)} \\
 \text{Maintenance Effectiveness} &= 1 - (M1 + M2 + M3)/S \\
 &\text{(100 \% if no maintenance)} \\
 \text{Availability (Total)} &= 1 - (M1 + M2 + M3)/T \\
 &\text{(of equipment from maintenance as related to total time)} \\
 \text{Availability (When Required)} &= 1 - LP/(SP - NR) \\
 &\text{(all causes)} \\
 \text{Relative Maintenance Losses} &= M3/LP \\
 &\text{(lost time due maintenance as a proportion of all lost time)}
 \end{aligned}$$

There is also a possibility of opportunistic maintenance in nonscheduled time.

21.17 Maintenance Effectiveness

The effectiveness of maintenance relates to how well the effort put into maintenance translates into reliable and available equipment. Figure 21.16 shows factors that influence the effectiveness of maintenance. The skill of the maintenance workforce in relation to the tasks on hand is a key factor, and training and

Total Time, T						
Scheduled Time, S					Non-scheduled time	
Scheduled Production Time, SP				Scheduled Maintenance Time, M1	Non-scheduled time	
Actual Production Time, AP	Lost Production Time, LP		Production Not Required Time, NR		Scheduled Maintenance Time	Non-scheduled time
Actual Production Time, AP	Lost Prod Time due Maint. M3	Lost Prod Time due Other, LO	Not required other	Opportunistic Maintenance Time, M2	Scheduled Maintenance Time, M1	Non-scheduled time

Fig. 21.15 Availability related to total time

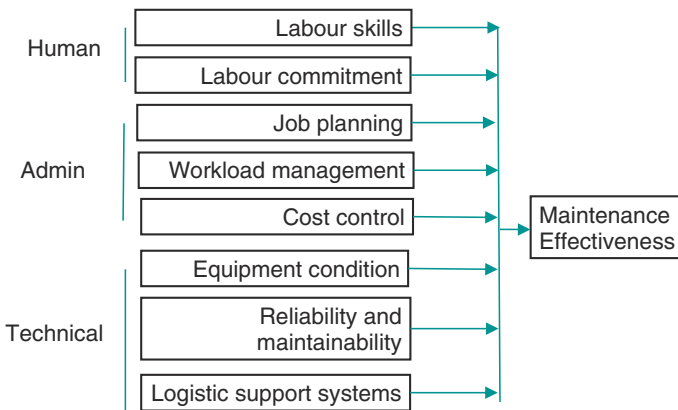

Fig. 21.16 Inputs to maintenance effectiveness

continuity on the job are therefore important. Possibly, the most important factor of all is the degree of commitment or motivation of the workforce—an indicator of lack of commitment is absenteeism. The degree of commitment is influenced by the other factors in the figure, since lack of cleanliness, poor planning, inherently unreliable equipment, and poor logistic support will lead to poor morale.

Maintenance personnel generally welcome being involved in work on improving reliability and maintainability, such as RCA, diagnosis, and condition monitoring. However, a tendency to replace basic maintenance by sophisticated but ineffective activities should be resisted.

21.18 Maintenance Load

The maintenance load generated by a system is the resource requirement for maintenance of the system per unit of service. For example, for an aircraft this is the maintenance hours per flying hour. The maintenance load will consist of routine and nonroutine activities, of which the latter can only be estimated on the basis of some operating experience. It may also be expressed in cost terms, such as maintenance \$ per flying hour.

21.19 Maintenance Regime

It is important to have an established maintenance regime, and for this to be documented, adhered to, and records kept. Conforming to the manufacturers recommendations, meeting all regulatory requirements, and staying within warranty claim boundaries are good basic ideas. Variations from this need a reason. Be confident about what you can tell the judge in a court case.

The maintenance regime specifies the details of what maintenance is done routinely, by whom and at what frequency, and the procedures for both routine and nonroutine maintenance.

21.20 Maintainability^{14,15}

Maintainability relates to the ease or difficulty with which an item can be repaired when it fails. A basic factor in maintainability is the *Mean Time to Repair (MTTR)*. This is defined as the average length of active time taken to repair an item which has failed. An item which is easy to repair will have a short MTTR, and an item which is hard to repair will have a longer MTTR. As a more formal measure, it is the proportion of repairs that are completed within a specified *maintenance time constraint*.

21.20.1 Design for Maintainability

Maintainability is a design factor which competes with other requirements such as low initial cost, good performance, and reliability. For example, it may improve the maintainability of a chemical reactor vessel to have an access plate in a certain

¹⁴ IEC 60300 3 10 Maintainability.

¹⁵ Blanchard, Benjamin S and Lowery, E.Edward. "Maintainability", McGraw-Hill 1969.

spot, but this may also increase the cost and reduce performance because of reduced allowable pressure, and may decrease reliability, because of the need for seals which are less reliable than a solid wall. In designing for maintainability, the general aims are to reduce total maintenance load and to reduce downtime when it occurs.

A good design will minimize and simplify maintenance tasks, and provide predictability in maintenance requirements. Specific features which promote good maintainability include ease of access by technicians; visibility; ease of testing; interchangeability of components or modules; provision of good maintenance documentation and diagnostics. Some further details of techniques used to provide good maintainability are as follows:

- *Access* Provide good access for maintenance.
 - Access plates.
 - Use hinged panels.
 - Use roll out drawers...
- *Modularise* Example: Maintainability of an electronic device may be improved by making it in the form of detachable boards plugged into a base. The plugs, however, may have low reliability when compared with permanent joints.
- Minimize need for special tools.
- Minimize range of tools required.
- Provide failure signals, warning signals, and built-in sensors.
- Provide troubleshooting, diagnostic aids and plans.
- Built-in monitoring points.
- Provide good instrumentation.
- Label assemblies.
- Provide operation and calibration information on labels.
- Use easily replaceable, expendable components, e.g., flywire door.
- Prevent faulty assembly (poka yoke).
- Provide handles or other lifting points.
- Provide castors.
- Lubrication points visible and accessible.
- Adjustment points visible and accessible.
- Provide spare fuses or equivalent reset.
- Provide adequate illumination.
- Redundancy, e.g., standby light bulb with switch.
- Help desk, online maintenance support, and portable computer with workshop manuals and drawings, etc.

An example of poor design for maintainability is shown in Fig. 21.17.¹⁶

¹⁶ Blischke W.R. and Murthy D.N.P. Case studies in Reliability and Maintenance, Wiley, 2003.

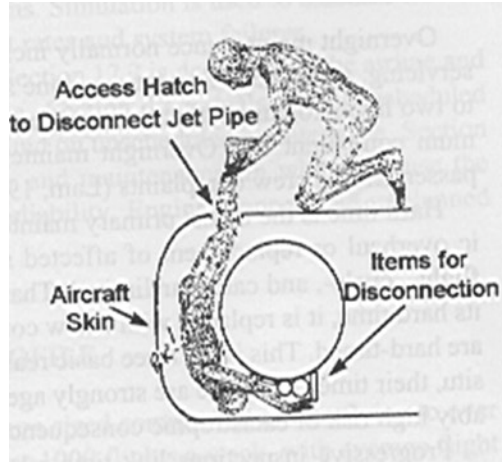

Fig. 21.17 A maintainability nightmare

21.21 Maintainability Measure

In order to specify, measure, and compare maintainability of items, we need a definition of maintainability as a measurable quantity. For this purpose, we define maintainability as a probability that an item can be restored to operating condition within a specified interval of time, when maintenance is performed in accordance with prescribed procedures and resources. The following definition is adapted from Society of Automotive Engineers Standard SAE JA1010.

Maintainability is the probability that an item will be repaired within a specified time, referred to as the *maintenance time constraint*.

The Maintenance Time Constraint is set in relation to operational circumstances, such as, aircraft turn around time. As a property of the item itself, maintainability is related to Active Repair Time. As a property of a system, maintainability is related to total downtime.

The average value of the time to repair is known as the MTTR. If the distribution of the time to repair is negative exponential, the repair rate is constant and is the reciprocal of the MTTR. Define

MTTR = Mean Time to repair

μ = Repair Rate

Then for the exponential model we have

$\mu = 1/\text{MTTR}$

$M = 1 - \exp(-\mu t)$

where M is the Maintainability and t is the Maintenance Time Constraint. Thus, if we have data from which we can estimate the Mean Time To Repair, then we

can calculate the corresponding maintainability with reference to our maintenance time constraint.

21.22 Desert Song

“So where did you go after Norway, Pop?” asked Jock on his next visit to his granddad. Jock really enjoyed hearing his Pop’s old stories but it was hard to get him going on them.

“What sort of stuff are you working on now?” said Pop, diverting the question.

“It’s about sustaining our in-service assets, but I think you would call it maintenance,” said Jock; and after a pause Pop decided there were some things about maintenance that Jock ought to know.

“We were in North Africa,” said Pop. “You know those films with John Wayne firing a machine gun from the hip from a moving tank?”

“Yes,” said Jock

“Well it’s not like that. The fact is that tanks get stuck or break down pretty easily. There is always soft sand or mud, unexpected gullies, rocks or concrete in the wrong place. It’s surprising how easily they can throw a track or strip the final drive or just get into a spot where they can’t move. And that’s not counting enemy action or mines. After a day’s fighting in the desert dozens of tanks on both sides would be broken down somewhere. But somehow the Germans had most of theirs up and running again by next morning. It had us flummoxed at first.

“We found that they had the field maintenance angle well worked out. They had recovery vehicles with a winch and a spade which could pull a tank out of any spot, and repair teams trained and equipped with all the right tools and spares.

“At that time we didn’t even have a mechanical and electrical engineering corps at all. We just had fitters attached to the supply regiment.

“And we loved their petrol cans—jerry cans we called them. Our cans were so flimsy that they would start leaking at the drop of a hat.”

“Pretty bad eh,” said Jock.

“Before the war our staff blokes must have still been dreaming of the old cavalry days. They finally picked up on it after the Germans looked like they would make it to Cairo. By Alamein we began to get some better equipment through and a mechanical and electrical engineering corps was formed. Later when the Americans came in with the half-tracks we got our forward repair teams running too.”

21.23 Exercises

21.23.1 *Self-Assessment Exercise*

1. Define reliability.
2. Define MTBF.

3. Define Failure Rate.
4. What are toolbox meetings and why are they important?
5. What are the three common failure rate patterns?
6. What does FRACAS stand for?
7. What is Pareto analysis?
8. What is RCA?
9. What is the five whys RCA technique?
10. What is Condition Monitoring?
11. What is RCM?
12. What are hidden failures?
13. What is maintenance policy review?
14. What is availability?
15. What is meant by the maintenance load of an asset?
16. Identify five factors which are important for good maintainability of an asset.

21.23.2 Pacific Earth Moving Pt 6: Reliability and Availability

In addition to routine maintenance activities, Pacific Earth Moving needs to achieve high standards of equipment availability in its mobile plant fleet in order to meet targets set in its contracts with client companies.

At present the availability levels are below target. You have been asked to advise the company on what methods or techniques should be introduced in order to improve the reliability and availability for the company's plant. Give your answer in dot point form, stating the features of each approach and indicating the potential benefits and costs.

21.23.3 Cost of Downtime

A single conveyor brings mineral ore from a mine to the surface. The conveyor operates full time, which in this case is 48 weeks/year, 48 h/week. Extension of this working period is not practicable. Experience shows that conveyor availability is 87 %. The sales value of production is \$30,000,000 per year. Estimate the hourly cost of downtime in terms of lost sales revenue. The conveyor system uses minimal consumables.

21.23.4 Availability Related to Total Time

A plant makes two types of coiled spring, Small and Large. The standard production times are:

Small 3 min per spring

Large 4 min per spring

The plant works nine 8 h production shifts per week, with an additional maintenance shift of 8 h.

In a given week, the following data are recorded.

Production: Smallsprings 578

Large springs 492

Unscheduled Downtime due to Maintenance: 7 h 30 min

Calculate the ratios referred to in Fig. 21.15:

$$\text{Availability (When Required)} = 1 - M3 / (SP - NR)$$

(of equipment from maintenance when required)

$$\text{Maintenance Effectiveness} = 1 - (M1 + M2 + M3) / S$$

(100 % if no maintenance)

$$\text{Availability (When Required)} = 1 - LP / (SP - NR)$$

(all causes)

$$\text{Relative Maintenance Losses} = M3 / LP$$

(lost time due maintenance as a proportion of all lost time)

How much time is lost during production shifts for reasons other than maintenance? Assume that there is no “Not Required” time.

21.23.5 Hydraulic Faults

In an application involving the extensive use of hydraulic machinery, verbal reports indicate frequent failure of hydraulic systems. Technicians say that hoses are often the source of problems. What would you do?

21.24 Exercise Solutions

21.24.1 Self-Assessment Exercise Solution

1. *Define reliability.*

Reliability is the ability of an item to perform a required function under stated conditions for a specified period of time.

2. *Define MTBF.*

MTBF is the average time for which an equipment operates between failures occurring.

3. *Define Failure Rate.*

Failure rate is the number of failures per unit of operating time.

4. *What are toolbox meetings and why are they important?*

A toolbox meeting is a meeting of maintenance personnel with supervisors and planners, typically held weekly as part of the maintenance planning and scheduling process. Feedback from maintainers forms a valuable source of information relating to in-service asset reliability. The key step here is for management to listen to the feedback and to take corresponding action where warranted.

5. *What are the three common failure rate patterns?*

Burn-in, random, and wearout.

6. *What does FRACAS stand for?*

Failure Reporting and Corrective Action System.

7. *What is Pareto analysis?*

Pareto analysis, as applied to equipment failures, means ranking failure modes by frequency and cost.

8. *What is RCA?*

RCA also known as RCFA is a formal approach to determining the cause of failures, with the intention of preventing future occurrences.

9. *What is the five whys RCA technique?*

Five Whys is a technique of RCA which consists of asking “Why” something happened, and then why the previous thing happened and so on, until an explanation is found. All the answers can be important.

10. *What is Condition Monitoring?*

Condition monitoring involves using a diagnostic technique with the aim of detecting degradation of a function or component before failure occurs, with a view to taking remedial action to prevent in-service failure.

11. *What is RCM?*

RCM is a systematic method for establishing a maintenance policy.

12. *What are hidden failures?*

Hidden failures are failures which are not readily apparent to the operator of the equipment.

13. *What is maintenance policy review?*

Maintenance Policy Review is a procedure for checking the suitability of the existing maintenance tasks.

14. *What is availability?*

Availability is the proportion of time for which a machine is available for use.

15. *What is meant by the maintenance load of an asset?*

The maintenance load generated by a system is the resource requirement for maintenance of the system per unit of service.

16. *Identify five factors which are important for good maintainability of an asset.*

- Accessibility
- Modularity
- Diagnostic aids

- Redundancy
- Labeling
- Other items in Sect. 21.21.

21.24.2 Pacific Earth Moving Part 6: Solution

- System of review and response to operator reports of losses or faults
- Incident reporting and management
- FRACAS
- FMEA
- RCM or related review of maintenance regime
- RCA
- Condition monitoring, oil, vibration, thermal, etc.
- Maintainability analysis
- Spare parts service level review, value turns, and control settings
- Repair pools and rotables provision and planning
- Component replacement policy analysis
- Forward repair teams
- Workshop facilities provision
- Equipment replacement planning.

21.24.3 Cost of Downtime

$$\begin{aligned} \text{Hours per year} &= 48 \text{ weeks} \times 48 \text{ h} \times 87 \% \text{ availability} \\ &= 2,004 \text{ h} \end{aligned}$$

$$\text{Cost of downtime per hour} = \$30,000,000 / 2,004 = \$15,000.$$

21.24.4 Availability Related to Total Time

Scheduled Time = $S = 80 \text{ h} = 4,800 \text{ min}$

Scheduled Production time = $SP = 4,320 \text{ min}$

Scheduled Maintenance time = $M1 = 480 \text{ min}$

Lost Prod. time due to maint. = $M3 = 450 \text{ min}$

Not Required time = $NR = 0$

Opportunistic maint. time = $M2 = 0$

Actual Production time = $AP = 578 * 3 + 492 * 4 = 3,702 \text{ min}$

Lost production time = $LP = SP - AP = 618 \text{ min}$

$$A(\text{WR}_{\text{maint}}) = 1 - M3/SP = 89.6 \%$$

$$\text{Maint. Effectiveness} = 1 - (M1 + M3)/S = 80.6 \%$$

$$A(\text{WR}_{\text{all causes}}) = 1 - LP/SP = 85.7 \%$$

$$\text{Lost Prod. Time other} = LP - M3 = 168 \text{ min}$$

$$\text{Relative Maint. Losses} = M3/LP = 72.8 \%$$

21.24.5 Hydraulic Faults Solution

Check the work order history to assess the significance of the problem. Carry out pareto analysis of hydraulic failures to check for main issues. Hoses are found to be the main source of problems. Carry out an audit of hose condition. Replace hoses in poor condition. Define and disseminate condition and inspection and replacement standards for hoses. Improve training. Ensure correct hoses are fitted, that fittings are sound, and that operators are aware of possible damage to hoses and are trained to avoid such damage. Operators and inspectors to report leaking or damaged hoses, with follow-up repair.

Chapter 22

Safety

Abstract The aim of this chapter is to outline the main factors involved in general safety issues related to asset management. Safety critical systems are also considered and techniques applicable to high-risk plant are introduced. *Outcomes* After reading this chapter you will be aware of safety issues in two main areas. First there are general safety concepts which apply to all physical assets. Second, there are concepts such as safety integrity levels which apply to high-risk plant. You will also be aware of the need for approved engineering standards to be applied by competent personnel when developing repair specifications.

22.1 Safety Requirements and Competence¹

Safety of users, operators, and maintainers is a general requirement for asset-based systems.

The management of safety requires the existence of an organizational capability that is competent to determine and apply the procedures necessary to meet the related safety standards. Personnel must be aware of safety regulations that are applicable to the relevant assets and their uses. These regulations will provide guidelines for the conduct of operations and maintenance.

Personnel engaged in the operation or maintenance of systems must adhere to safety regulations and practices that are applicable. Competency is to be assured by a combination of a qualifications framework, competency standards, and competency assessment procedures.

Training programs are needed to deliver and support safety knowledge and practices. Staff members require documented records which identify the training and competencies achieved. Regular reviews or audits must be carried out of safety competencies required and achieved by staff members. This provides the opportunity to correct skill gaps if any.

¹ ISO 55002 Clause 4.4 Asset management systems: “A factor of successful asset management is the ability to integrate with ...other functions e.g.....safety...”.

Contractor competency in regard to safety is reviewed as part of the contract tendering process with ongoing contractor performance reviews and workplace assessments.

22.1.1 Safety Practices

Identify, publicize, and enforce good safety practices in relation to the following:

- Standard operating conditions
- Actions when deviations occur
- Incident reporting procedures
- Accident reporting procedures
- Isolation procedures
- Emergency procedures
- Electrical safety
- Radio use
- Fire protection
- Driving rules
- Manual handling rules
- Use of protective clothing: Helmets, Footwear, Goggles, Gloves, Ear Muffs, and Respirators
- No smoking areas
- Behavior: No horseplay, alcohol, drugs, walk do not run, and hold the hand rail
- Good housekeeping
- Color coding of pipes and valves
- Paint the name of the fluid inside on the pipe or valve
- Label equipment which is supplied from a switch or valve
- Identify water quality as potable or otherwise
- Remove hazardous material
- Check that concentrations of toxic substances are low enough for safety
- Remove items that may collect foreign objects, toxic material or corrosion, e.g., dead ends of old pipes
- Keep unnecessary people away
- Have a works modification approval procedure and form
- Use portable gas detector alarms
- Avoid having welding or grinding sparks in potentially dangerous places.

All maintenance work is to be carried out under appropriate isolation with all the hazards identified and risks assessed. Nonroutine maintenance tasks are to be subject to appropriate job safety hazard analysis and risk management procedures.

Specify and apply testing and acceptance criteria for when repair is complete.

22.1.2 Training and Information

Provide training in:

- Safety procedures
- Protective clothing
- Personal equipment
- Permits
- Follow-up actions.

Consider physical factors such as:

- Weight to be lifted,
- Accessibility,
- Reach,
- Visibility, and
- Hazards.

Make instructions available in simple forms:

- check lists,
- photographs,
- videos,
- graphics.

Carry out test runs of procedures with novices.

Check for possible missing steps, ambiguity.

22.1.3 Permits

A system of permits is required covering work in hazardous circumstances, such as:

- Confined space
- High level
- Ground opening
- Hot work
- Permit to work (from operations).

The person who signs the permit should always check first to assess the potential hazards involved and the current conditions. For confined spaces, there should be a standby person. Possible sources of danger include low level of oxygen; toxic gas; and flammable gas.

22.1.4 Tags

Tags are used to as a sign that equipment is out of service or under repair. Tags indicate that equipment is not to be switched on except by, or on the authority of, the person who placed the tag.

- *Out of service tag* Placed on a switch indicating plant must not be switched on because it needs repair. This is to prevent damage to plant.
- *Personal danger tag* Placed on a switch indicating that a (named) person is working on the machine. This is to prevent personal injury.

22.1.5 Danger Indications

Operators and maintainers should have a general awareness of possible indicators of danger and must be aware of what action to take in response to:

- Alarms
- Instruments indicating out of specification
- Leaks
- Flames
- Unexpected hot spots or cold spots
- Ice where no ice should be
- Vapor
- Loose equipment.

22.2 Safety Critical Equipment (SCE) and Systems (SCS)

Safety critical equipment or systems are items, the failure of which can endanger human life or cause significant damage. These systems are normally subject to statutory design and maintenance requirements. The engineering management of such systems is addressed by the topic of Systems Engineering² and by specific topics relating to high-risk industries.³

Safety critical systems require the application of techniques designed to assess and assure the safe operation of high-risk plant. These systems occur in plant operating at high or low temperatures and pressures, particularly where these contain flammable, toxic, or hazardous materials, such as are found in the oil and gas, chemical, and mineral processing industries. Inspection techniques apply to the

² ISO 15288 Systems Engineering—Systems Life Cycle Processes.

³ IEC 61511-1 Functional safety, Safety Instrumented Systems.

pipes and pressure vessels, pumps, valves, compressors, hoses, and protective devices. The same principles apply to other safety-related structures such as lifting and fairground equipment. The design of systems for safety involves the use of items such as safety valves, redundant systems, back-up systems, and instrumentation to warn of or close down dangerous situations. The use of protective clothing and equipment and of safety procedures are also important in these applications.

The integrity of safety critical systems involves some features over and above those normally found for more general systems, although there is a considerable overlap. Some specific points are covered in this section, however, this is a very extensive subject and the intention is only to indicate the main concepts.

22.2.1 Safety Critical Examples

The following are some examples of safety critical equipment or systems:

- boilers, pressure vessels, and piping
- anything involving hazardous or toxic substances
- cranes, hoists, and elevating work platforms
- amusement devices
- lifts and escalators
- air conditioning units and cooling towers
- gas cylinders
- aviation systems
- railway systems
- nuclear industries
- storage tanks
- wells and wellhead equipment
- fire detection systems
- fire extinguishing systems
- instrumentation associated with safety.

22.2.2 Risk-Based Inspection

High-risk applications have substantial associated documentary and regulatory systems. Those for the oil and gas industry are developed by the American Petroleum Institute.⁴ The term Risk-Based Inspection is used in describing the techniques which have been developed for addressing safety issues in these industries.

⁴ API 580 and API 581 Risk Based Inspection.

of system that includes pressure vessels and piping, pumps, valves, instrumentation, sensors for pressure, temperature, level and flow and related controls.

22.2.4 Asset Integrity Management Plan (AIMP)

Systems such as the distillation system shown in Fig. 22.1 require an asset integrity management plan. An Asset Integrity Management Plan (AIMP) is a management plan specifically aimed at ensuring the integrity of safety critical equipment. It will include the following elements:

- Identification of Safety Critical Equipment (SCE) in the equipment register, to include tag number, nameplate data.
- Identification of Safety Instrumented Systems (SIS) and Safety Integrity Functions (SIF), which are systems or functions required to ensure safe operations and safe response to any departure from normal operating conditions.
- Analysis of Safety Critical Equipment (SCE), SIS, and SIF to determine the requirements for inspection and maintenance by activity and frequency.
- Development and application of integrity management and safety and operating plans.
- Development of detailed procedures for inspection and maintenance work including relevant test, performance or monitoring standards.
- Documentation of all procedures in the Asset Management Information System
- Management of these procedures through the Asset Management Information System.

22.2.5 Maintenance Specific to Safety Critical Equipment

Activities will typically include the following. The frequencies may be based on statutory requirements, reliability statistics, vendor recommendations, and best practice.

- Pressure Safety Valve (PSV) testing
- Functional tests (Emergency Shutdown (ESD) system, fire and gas detectors, etc.)
- Critical Function Testing of Safety Instrumented Systems (SIS)⁵ and Safety Instrumented Functions (SIF)⁶
- Statutory vessel and piping inspections
- Instrument calibration

⁵ IEC 61511.

⁶ AS 1851 (Clause 1.11) and AS 4428 (Clause 4.2).

- Periodic running tests of standby equipment
- Mechanical and performance tests of any equipment (including fire pumps)
- Specify and apply testing and acceptance criteria for when repair is complete
- Reference vendor manuals that describe the maintenance and testing requirements for the maintenance procedures
- Maintenance activities must preserve the integrity of the safety systems.

22.2.6 Internal Corrosion Management

Internal corrosion presents significant risk to pressure equipment and pipelines particularly when corrosive substances are present. An internal corrosion control plan is developed for each facility to establish control and mitigation methods for managing corrosion, and also to monitor and assess the effectiveness of the corrosion management systems that have been implemented.

22.2.7 Protective Devices

Safety Critical Equipment often has protective devices, the functions of which need to be considered, such as:

- Fences
- Guards
- Fuses
- Circuit breakers
- Limit switches
- Safety valves
- Emergency stop buttons
- Overload cut outs
- Standby systems
- Smoke detectors
- Alarms
- Bursting discs
- Filters and filter by-passes
- Fire detection systems
- Fire water systems
- Gas alarms
- Governors
- Nonreturn valves
- Space alarms
- Sprinkler systems
- Tank vents

- Trips mechanical, electrical, other instrument
- Closed circuit television monitoring.

These have functions such as:

- Warn of danger
- Switch off or close down operation
- Relieve pressure
- Guard against foreign objects, e.g., hand in guillotine
- Provide standby service, e.g., emergency lighting.

22.2.8 Record Keeping⁷

Records of maintenance and function tests for safety critical equipment typically include the following information:

- Date of maintenance or function test
- Name of person who performed the maintenance or function test
- Serial number or other unique identifier of equipment (loop number, tag number etc.)
- Results of maintenance or function test
- Reference to work requests or work orders raised.

22.3 Layer of Protection Analysis (LOPA)^{8,9,10}

A layer of protection is something that reduces risk by a significant factor. In Layer of Protection Analysis, layers are added until a desired level of safety is reached. As an example consider a pressure vessel such as the distillation column in Fig. 22.1. This could burst causing damage. To protect against this we have layers of protection as shown in Fig. 22.2.

The initial layer of protection (numbered 1 in Fig. 22.2) is provided by a gauge and a warning light on a control panel. An operator should respond to this warning by taking action to make the situation safe. If the operator does not act, an audible warning signal (numbered 2) sounds to attract the attention of the operator. This is the second layer of protection. If the operator still does not act, a safety valve opens (numbered 3), and if this does not work or does not reduce the pressure sufficiently, an automatic

⁷ AS 1851 (Clause 1.15) and AS 4428 (Clause 3.2, 4.5).

⁸ IEC 61508 series and IEC 61511 describe LOPA and SIL.

⁹ CCPS/AIChE, Guidelines for Safe Automation of Chemical Processes, 1993, pp. 7–16.

¹⁰ Angela E. Summers, Introduction to layer of protection analysis, Journal of Hazardous Materials.

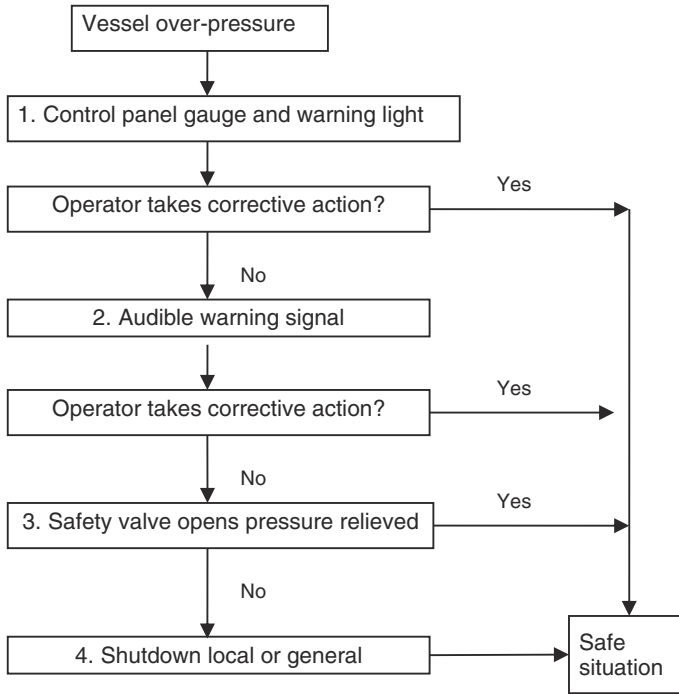

Fig. 22.2 Layers of protection

local or general shutdown (numbered 4) occurs. Thus in total there are four layers of protection protecting against potential damage caused by vessel overpressure.

22.4 Safety Integrity Level (SIL)

The Safety Integrity Level of a system is a measure of its relative safety as achieved by the application of Layers of Protection. Analytical techniques such as fault tree and event tree analysis may be applied in assessing a safety integrity level. Layers of protection may be added until the required safety integrity level is reached.

22.4.1 Design for Safe Operation

The following are some examples of techniques which can be applied in design for safe operation.

- Procedures and action to be taken in response to specific readings of instruments or signals, e.g., pressure, temperature
- Setting control trips

- Selection of automatic control and operation overrides
- Establishment of safety limits on plant characteristics, e.g., thinning of pipes
- Inspection practices and follow-up action
- Maintenance tasks and intervals
- Design of operation interlocks
- Design and operation of protection systems
- Automatic shutdown or restriction of plant operation based on Safety Instrumented Systems or Safety Integrated Functions
- Formulation of recovery methods
- Root cause analysis of trips and faults.

22.4.2 Facility Siting and Layout

Ref: OSHA (USA) CFR 1919.119. API RP-752. Consider process hazards, including fire, explosion, and toxicity, in relation to:

- Site workers;
- Location of control room;
- Occupants of buildings;
- Nearby residents; and
- Access to emergency facilities.

22.4.3 Fitness for Service Assessment

Fitness for service criteria are to be established and applied to assets. These will specify inspection and performance standards relating to such issues as the following. Reference should be made to industry standards where appropriate. For example, for the oil and gas industry, see API 579.

- Thickness of pipes and pressure vessels;
- Cracks, e.g., in structures, cranes;
- Misalignment;
- Vibration;
- Levels of corrosion or wear;
- Insulation resistance in transformers and other electrical equipment.

22.5 Repairs Requiring Engineering

If a particular repair is required but is not included in the existing maintenance manual, then engineering will be required to design the repair. Examples are: the extent of weld repairs for corrosion, the extent of what has to be replaced after

unusual events, e.g., fire or impact damage; the need of cutting away structures for access during equipment upgrades, a repair specification is required to cover the safe restoration of the affected structures.

A *repair specification* is a repair procedure which is authorized by a competent authority for a specific maintenance activity. The competent authority can be an individual, a company, or a group of qualified engineers. The data associated with a repair generally consists of drawings and analysis that show compliance to regulations. The key task is to make certain that the repair specification does not violate any of the assumptions made in the design of the repaired engineering system.

22.6 Terminology Summary

Cause and Effect Matrix (C & E)
Emergency Shutdown System (ESD)
Fire and Gas (F & G)
Layer of Protection Analysis (LOPA)
Piping and Instrumentation Diagram (P & ID)
Process Flow Diagram (PFD)
Process Shutdown System (PSD)
Process Safety (PS)
Pressure Safety Valve (PSV)
Safety Critical Equipment (SCE)
Safety Critical System (SCS)
Safety Integrity Function (SIF)
Safety Integrity Level (SIL)
Safety Instrumented Systems (SIS)

22.7 Exercises

22.7.1 Self-Assessment Quiz

1. Identify three or more essentials for safety management.
2. Identify three or more situations where permits to work are typically required.
3. Why are safety tags used?
4. What is Safety Critical Equipment (SCE)?
5. What organization is particularly involved in creating standards applicable to the oil and gas industries?
6. What types of safety issues are addressed by Risk-Based Inspection?
7. Identify five or more types of protective device used in high-risk plant.
8. Define the concepts of Layer of Protection and Layer of Protection Analysis.
9. Under what circumstances is engineering input required for approving repairs and what is an engineering approved repair specification?

22.7.2 Self-Assessment Quiz Solutions

1. *Identify three or more essentials for safety management.*
 - An organizational capability that is competent to determine and apply the procedures necessary to meet the related safety standards.
 - Awareness of safety regulations.
 - Competency in applying safety procedures.
 - Training programs.
 - Documented records which identify the training and competencies achieved.
 - Reviews or audits of safety competencies required and achieved by staff members.
 - Contractor competency.
2. *Identify three or more situations where permits to work are typically required.*
 - Confined space
 - High level
 - Ground opening
 - Hot work
 - Permit to work (from operations).
3. *Why are safety tags used?*
 Tags are used to as a sign that equipment is out of service or under repair. Tags indicate that equipment is not to be switched on except by, or on the authority of, the person who placed the tag.
4. *What is Safety Critical Equipment (SCE)?*
 Safety critical equipment or systems are items, the failure of which can endanger human life or cause significant damage.
5. *What organization is particularly involved in creating standards applicable to the oil and gas industries?*
 The American Petroleum Institute (API).
6. *What types of safety issues are addressed by Risk-Based Inspection?*
 High-risk applications in the oil and gas industry involving equipment such as pressure vessels and pipes and factors such as temperature, pressure and fluid type, and the type of metal used. Potential failure modes include:
 - Fatigue
 - Overheating
 - Thinning of pipes and vessels
 - External damage
 - Stress corrosion cracking
 - Creep
 - High temperature hydrogen attack
 - Brittle fracture
 - Equipment linings failure.

7. *Identify five or more types of protective device used in high-risk plant.*

Any five or more items listed in Sect. [22.2.7](#).

8. *Define the concepts of Layer of Protection and Layer of Protection Analysis.*

A layer of protection is something that reduces risk by a significant factor. In Layer of Protection Analysis, layers are added until a desired level of safety is reached.

9. *Under what circumstances is engineering input required for approving repairs and what is an engineering approved repair specification?*

If a particular repair is required but is not included in the existing maintenance manual, then engineering will be required to design the repair. A *repair specification* is a repair procedure which is authorized by a competent authority for a specific maintenance activity.

Part VI
Financial Analysis

Chapter 23

Profit, Depreciation, and Tax

Abstract The aim of this chapter is to describe how tax and depreciation are taken into account in asset management decisions. Asset managers work with accounting and financial specialists and need familiarity with the terminology and principles involved in dealing with issues of depreciation and taxation. *Outcomes* After reading this chapter you will understand how after-tax profit is calculated, how depreciation is calculated, and how asset management decisions are influenced by tax considerations.

23.1 Introduction

In this chapter, we consider the effect of taxation, insofar as it influences decisions relating to asset management. In an ideal world, taxes should be structured so that they have a neutral effect on business decisions, but in practice this is rarely the case. Tax is a complex area and it is not intended to address it in full detail here. The actual tax situation and the precise rules governing depreciation of a company's assets are the province of the accountant and in practice accountancy input into the related calculations is essential. However, for positive outcomes it is beneficial if asset managers are familiar with the main issues and terminology of company tax. We shall introduce, in a basic context, the main elements of tax and depreciation, and the concept of tax credits as a way of allowing for the effects of taxation.

23.2 Capital Transactions

Capital transactions involve the purchase or sale of fixed assets. They also include expenditure on asset creating projects, such as construction of buildings and infrastructure items such as roads or dams. Capital expenditure is not directly tax

deductible in the year when the money is spent, as it is assumed that one kind of asset (money) is being exchanged for another kind of asset (machinery, plant, buildings or infrastructure) and that this transaction does not affect the value of the firm. The depreciation of the asset is tax deductible, year by year over its effective life.

23.3 Depreciation

Depreciation is an amount by which the value of a capital item is decreased for accounting purposes, to approximately reflect its decreasing value with age. Depreciation is deductible from income in the current year, in determining taxable income, and hence in determining the tax to be paid.

As an item depreciates, its reduced value is referred to as its “*book value*” or “*written down value*”. The book value will not necessarily reflect the value of the item in terms of its practical usefulness as an asset at a particular stage of life. It is possible to adjust the book value to reflect market changes and changes in asset condition outside the normal deterioration with age.

23.3.1 Acquisition Cost

The acquisition cost of an item is the full purchase price plus any costs of transporting, installing, relocating, or erecting the item.

23.3.2 Book Value (or Written Down Value, WDV)

The book value of an item is its Acquisition Cost minus the Cumulative Depreciation to date.

23.3.3 Effective Life

Effective life is the age to which an item retains value, as specified in tax legislation as a basis for depreciation allowances. Some examples of effective lives as published by Australian tax authorities are shown in Fig. 23.1.

The effective life of an item can be varied from the tax office standard in some circumstances, provided this is supported by reasonable documentary evidence. One example is when an item which is not fully depreciated becomes unusable due to obsolescence. In this case the item may be written off, essentially the same

Item	Effective Life in Years
Aircraft general use	20
Conveyor belts	6.66
Cars	8
Pumps	20
Mining Compressors	15
Cranes	20
Dragline used in mining	20
Electricity industry storage batteries	13.33
Medical cat scanner	6.66
Sewerage treatment plant	20

Fig. 23.1 Examples of effective lives

as selling it for a zero resale value. The written down value is then claimable as a tax credit. Profit will be reduced, but is best to accept this and to keep the profit and the asset value in line with reality.

23.3.4 *Straight Line Depreciation*

There are a variety of ways of calculating depreciation and rules and rates vary from time to time and from jurisdiction to jurisdiction. Here we outline the principles of two common methods. The simplest method of depreciation is straight line depreciation. In straight line depreciation, the book value of the item decreases by a constant amount each year over its effective life, starting from the acquisition cost and falling to zero. The annual depreciation is given by the acquisition cost divided by the effective life. Figure 23.2 illustrates straight line depreciation.

23.3.5 *Residual Value*

Rather than depreciating to zero, items may be assigned a *residual value*. A residual value is a value to which the item falls and it then continues at that value from then on, until disposal. Figure 23.3 Residual Value illustrates this. The residual value may reflect an assessed value to the organization of an item

Fig. 23.2 Straight line depreciation

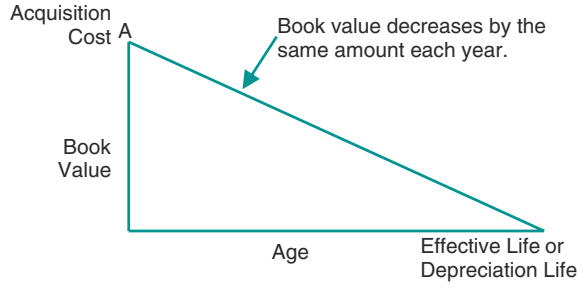
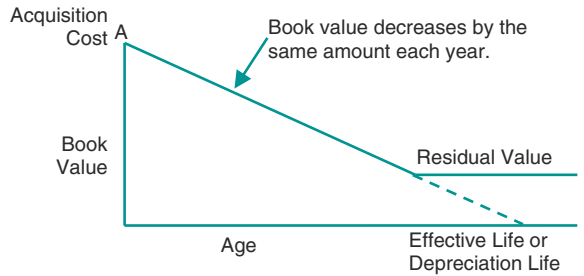

Fig. 23.3 Residual value



that continues to be functionally useful, or a scrap or trade-in value. In practice, any potential residual value is often lost in the cost of disposal and the true residual value of an item may be very small or even negative. However, if an item is to be retained on the books, it is advisable to assign it some value so that it retains its identity and accountability. Take advice from your accountants in regard to residual value.

23.3.5.1 Depreciable Amount

In cases where there is a residual value, the *depreciable amount* is the difference between the Acquisition Cost and the Residual Value.

23.3.6 Declining Balance Depreciation

In the declining balance method of depreciation the book value decreases by a constant proportion of its current value each year.

For example, at a depreciation rate of 25 %, the value will decline to 75 % of the original value in the first year and then by 25 % of that, to 56.25 % of the original in the second year, and so on. Figure 23.4 illustrates depreciation by declining balance.

Fig. 23.4 Depreciation by declining balance

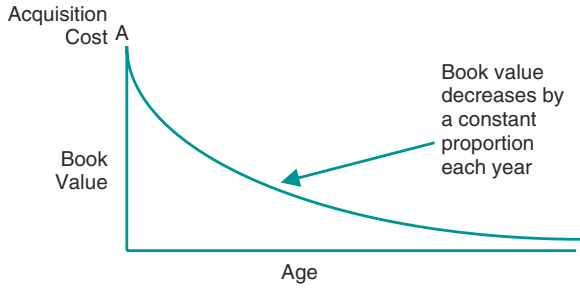

23.4 Profit and Loss Account

The profit or loss made by a company is calculated in an account called the Profit and Loss Account. Factors in determining the amount of profit made by a company are:

- Revenue
- Operating expenses
- Maintenance expenses
- Interest expenses
- Depreciation
- Tax.

The amount of profit is calculated by first calculating the *taxable income*, given by the sales revenue minus the various expenses and depreciation. The operating expenses referred to are typically made up of items, such as wages, fuel, materials, spare parts, leasing charges, and rents. Depreciation is the decline in the value of fixed assets in the year, calculated in accordance with accounting rules. *Company tax* is then calculated as a percentage of the taxable income. Subtracting the company tax from the pre-tax profit gives the after-tax profit for the organization. The results are shown in the Profit and Loss account, illustrated schematically in Fig. 23.5. Company tax is levied on taxable income, typically at a rate of about 30 %.

23.5 Profit Calculations

To discuss this further, we shall first consider how profits and tax are calculated.

Let:

- R* Revenue
- E* Expense (excluding depreciation but including interest)
- D* Depreciation

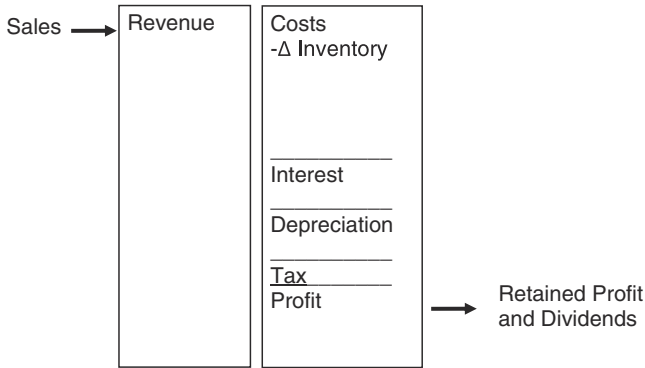

Costs are costs incurred in generating revenue, e.g. labour, materials, overheads. Δ Inventory is the change in the value of inventory held as current assets; this term can be positive or negative.

Fig. 23.5 Profit and loss account for a year

- c* Company tax rate
- T* tax
- Pbt* Profit before tax
- Pat* Profit after tax

$$\text{Profit before tax (Pbt)} = \text{Revenue} - \text{Expense} - \text{Depreciation} = R - E - D \tag{23.1}$$

$$\text{Tax} = \text{Profit before tax} * \text{Company tax rate} = (R - E - D) * c \tag{23.2}$$

$$\text{Profit after tax (Pat)} = (\text{Profit before tax} - \text{Tax}) = (R - E - D) * (1 - c) \tag{23.3}$$

We can rewrite this as:

$$\text{Profit after tax (Pat)} = R(1 - c) - E - D + E * c + D * c \tag{23.4}$$

23.6 Cash Flow Statement

Payments by an organization need to be funded, and cash requirements must be considered. If adequate cash is not on hand, money must be borrowed, and this will incur interest expense. Figure 23.6 illustrates a cash flow statement. Cash flow considerations influence financial thinking in regard to both capital and operating budgets.

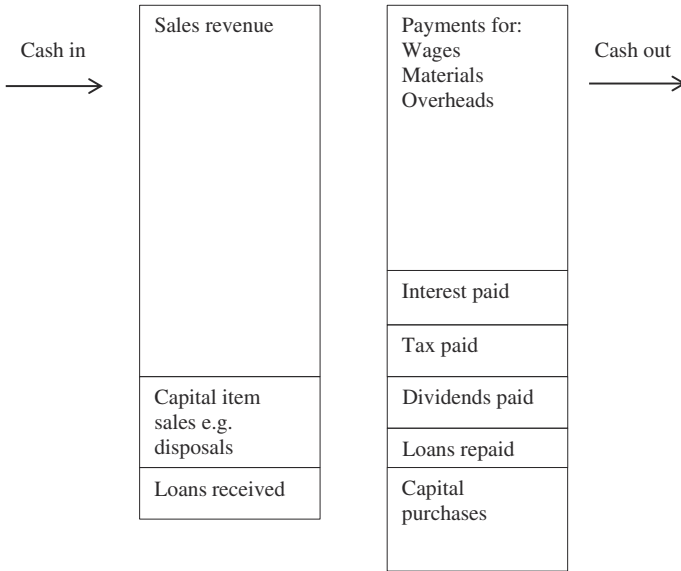

Fig. 23.6 Cash flow statement

Note that the cash outgoing for capital purchases occurs in the Cash Flow Statement (Fig. 23.6) but not in the Profit and Loss Account (Fig. 23.5).

23.6.1 Depreciation Tax Credit

A tax credit is an amount of money that a taxpayer is able to subtract from the amount of tax that they owe to the government. A depreciation tax credit is a credit arising from the tax deductibility of the depreciation of an asset.

The purchase of a fixed asset involves payment of the acquisition cost, A , at the time of acquisition—year zero. There is then a reduction in tax liability in subsequent years over the life of the item, as the depreciation is deducted from the pre-tax profit. The reduction in the tax paid, is “annual depreciation \times company tax rate,” $D \times c$, in terms of Eq. 23.4. This amount is known as a depreciation tax credit. The depreciation tax credit means that there is a reduced cash outflow in the form of tax paid.

The effective cash flow related to the capital cost of the fixed asset is therefore as shown in Fig. 23.7, for an item with a 4-year effective life, straight line depreciation D per year and company tax rate, c .

Note that the sum of the depreciation terms will be A , the acquisition cost, so that the whole of this cost is ultimately tax deductible, but the deductability is spread over the life of the asset.

Year	0	1	2	3	4
Cash flow	-A	+D*c	+D*c	+D*c	+D*c
A = Acquisition cost					
D = Annual depreciation					
c = Company tax rate					

Fig. 23.7 Depreciation tax credits, $D*c$

23.6.2 Maintenance Tax Credits

A maintenance tax credit is a cash flow arising from the tax deductibility of maintenance.

Company expenses are denoted by E in Eq. 23.4. The after-tax cash flow due to expenses but allowing for tax deductibility is $E * (1 - c)$. Maintenance is part of the expenses, so for a maintenance cost M we have an after-tax cash flow in the year of $-M * (1 - c)$.

23.6.3 Tax Credit Summary

We see that the effect of company tax on earnings is equivalent to bringing in the following three adjustments:

- reducing the revenue, R , by an amount $R*c$,
- reducing the annual expenses by $E*c$,
- adding income of amount $D*c$.

The term $R*c$ will normally be bigger than the operating plus depreciation tax credits, so although the cost part of the cash flow is reduced, the revenue part will be reduced even more, with net cost being exactly equivalent to the amount of tax to be paid.

23.6.4 Tax on Resale

On resale of an asset, tax is payable on the difference between the resale price realized, S , and the written down value, W .

$$\text{Tax on resale} = (S - W) * \text{company tax rate.} \quad (23.5)$$

If $W > S$ this becomes a tax credit, otherwise it means that additional tax is payable.

23.7 Pre-tax and After-Tax Cash Flow Diagrams

To summarize the effect of this analysis on a typical fixed asset, we introduce the following nomenclature:

- A Acquisition cost
- i Year of life
- $M(i)$ maintenance expense in year i ,
- $D(i)$ depreciation in year i
- $S(n)$ resale price realized at end of year n
- $W(n)$ book value at end of year n
- c company tax rate

The tax-credit adjusted maintenance expenditure in year of life i is:

$$M(i) * (1 - c) \tag{23.6}$$

The depreciation tax credit is

$$D(i) * c \tag{23.7}$$

The tax credits for year i will be received at the end of year i (at best).

23.7.1 Pre-tax Cash Flow Diagram

For an asset with a 4-year effective life, the pre-tax cash flows are shown in Fig. 23.8.

Fig. 23.8 Pre-tax cash flow diagram

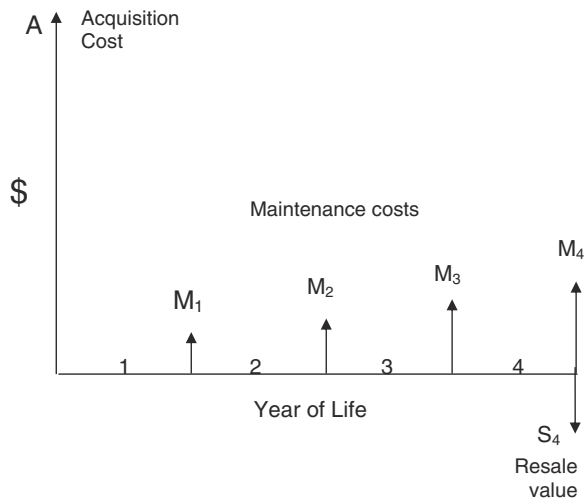

23.7.2 After-Tax Cash Flow Diagram

A cash flow diagram is shown in Fig. 23.9 which allows for the impact of company tax by bringing in the depreciation and maintenance tax credits and the tax adjustment on resale.

23.8 Conclusion

When assessing project alternatives, we should look for the alternative which maximizes after-tax profits. However, in many asset management applications, the revenue and the operating expenses are dependent on business factors which lie outside the scope of asset management decision making. It is also difficult to accurately assign profit contributions to particular assets. We may therefore focus on minimizing costs initially, taking account of “tax credits.” Subsequently, we may need to assess the effect of different options on the revenue and operating costs.

The effect of tax on asset decisions arises from the fact that expenses are tax deductible in the current year, whereas capital expenditure is only tax deductible on a deferred basis, in the form of depreciation. This tends to favor repair over replacement and leasing over purchase, but the extent of this depends on the relative underlying costs. In particular, since repairs to equipment are tax deductible in the current year, this may make it attractive to postpone a replacement, but we need to be sure that the repairs will deliver adequate reliability and availability over the remaining life of the equipment, so that the savings are not more than offset by losses in performance.

Fig. 23.9 Tax-adjusted cash flow diagram

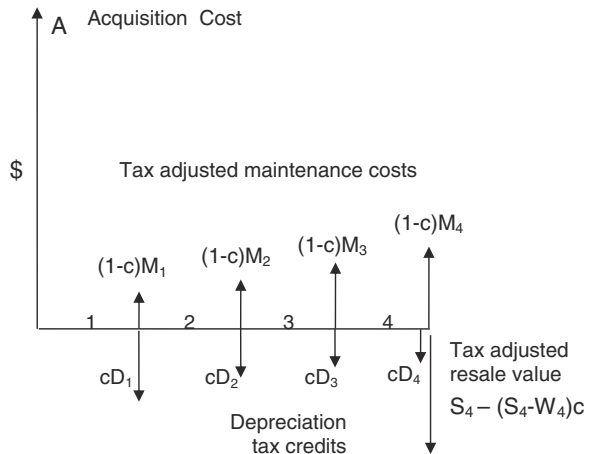

23.9 Exercises

23.9.1 Self-Assessment Exercise 23

1. Identify the three types of activity that involve capital transactions.
2. What is depreciation?
3. Define the “book value” or “written down value” of a fixed asset.
4. Define the “effective life” of an asset.
5. What is Straight Line Depreciation?
6. Why is Cash Flow important to an organization?

23.9.2 Profit Calculation Exercise

In a given year, an organization has a revenue of \$200 million and expenses (excludes depreciation) of \$70 million. The book value of its fixed assets is \$500 million. The assets have an average effective life of 10 years and straight line depreciation is used. Calculate the organizations profit before and after tax, given a company tax rate of 30 %.

23.10 Self-Assessment Exercise 23 Solution

1. *Identify three types of activity that involve capital transactions.*
 - a. Purchase of fixed assets
 - b. Sale of fixed assets
 - c. Asset development projects such as constructing buildings, roads or dams.
2. *What is depreciation?*
 - a. Depreciation is an amount by which the value of a capital item is decreased for accounting purposes, to approximately reflect its decreasing value with age.
3. *Define the “book value” or “written down value” of a fixed asset.*
 - a. The book value or written down value of an asset is its Acquisition Cost minus the Cumulative Depreciation to date.
4. *Define the “effective life” of an asset.*
 - a. Effective life is the age to which an asset retains value, as specified in tax legislation as a basis for depreciation allowances.
5. *What is Straight Line Depreciation?*
 - a. In straight line depreciation the book value of the asset decreases by a constant amount each year over the effective life, starting from the acquisition cost and falling to zero.

6. *Why is Cash Flow important to an organization?*

- a. Payments by an organization need to be funded, and cash requirements must be considered. If adequate cash is not on hand, money must be borrowed, and this will incur interest expense.

23.10.1 Profit Calculation Exercise—Solution

In a given year, an organization has revenue of \$200 million and expenses (excludes depreciation) of \$70 million. The book value of its fixed assets is \$500 million. The assets have an average effective life of 10 years and straight line depreciation is used. Calculate the organizations profit before and after tax, given a company tax rate of 30 %.

$$\text{Revenue (R)} = 200$$

$$\text{Expense (E)} = 70$$

$$\text{Asset value} = 500$$

Depreciation rate over 10 years is 10 % of asset value per year.

$$\text{Depreciation (D)} = 500 * 10 \% = 50$$

$$\text{Profit before tax (Pbt)} = R - E - D = 200 - 70 - 50 = 80$$

$$\text{Tax(T)} = 30 \% * \text{Pbt} = 30 \% * 80 = 24$$

$$\text{Profit after tax (Pat)} = \text{Pbt} - T = 80 - 24 = 56$$

Answer: Profit before tax = \$80,000,000. Profit after tax = \$56,000,000.

Chapter 24

Asset Decision Examples

Abstract The aim of this chapter is to present some examples of cases where asset decisions are required and to illustrate the financial and operational considerations involved. *Outcomes* After reading this chapter you will be aware of the application of discounted cash flow to repair or replace decisions and equipment acquisition decisions and the importance of taking operational factors into account in the overall decision-making process.

24.1 Repair/Replace Decision for Ore Loading Vehicles

The following example illustrates the use of discounted cash flow analysis to assist in analyzing a decision on whether to repair or replace an ore loading vehicle in an underground mine. As well as illustrating the use of discounted cash flow, the example illustrates the importance of using management judgment in regard to the operational factors involved in the analysis. In fact, the financial analysis is the simple part for any given set of facts. The hard part is deciding what factors should be taken into account and estimating the costs, revenues, and risks involved.

24.1.1 Situation

A mining company owns several vehicles of a type known as Load-Haul-Dump Trucks, usually referred to as “loaders”. The loaders are used underground to move rock containing copper, lead, and silver ores, which has been broken up by blasting. The environment is hot, rough, and abrasive and the maintenance costs are high. Figure 24.1 shows one of the loaders at work.

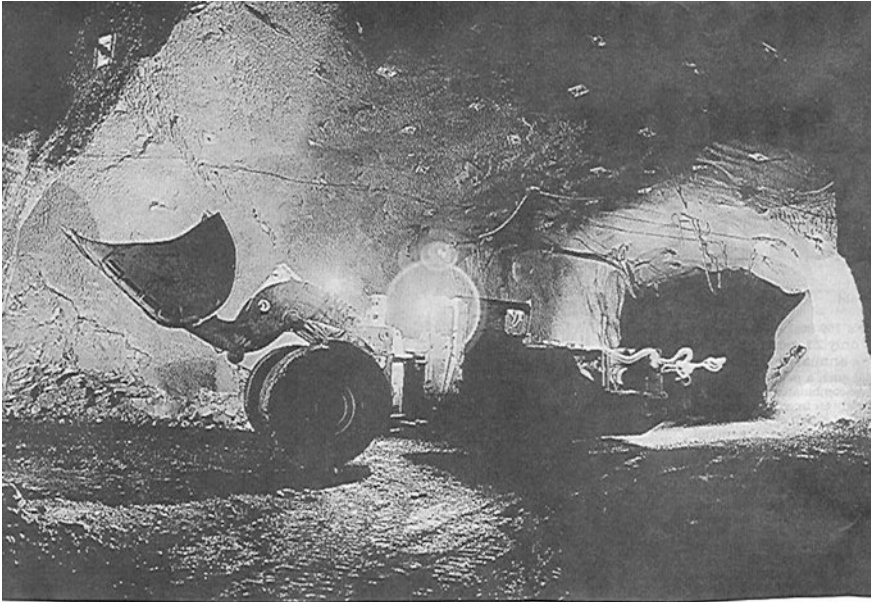

Fig. 24.1 Load-Haul-Dump truck at work

24.1.2 Required Decision

We have an existing 4-year-old loader and we need to decide whether to trade it in for a new one or to overhaul it and continue to use it for another 4 years. Thus, we are looking at two options:

- Replace Option—we replace the old loader, trading it in for a new one.
- Overhaul Option—we overhaul the old loader and keep it for four more years.

24.1.3 Factors Involved in the Replace or Overhaul Decision

Initially, we make a list of those factors that are relevant to our decision. Subsequently, we shall see how the story unfolds through several stages of analysis. The factors that we come up with are as follows:

- a. Cost of a new loader.
- b. Trade-in value of old loader.
- c. Overhaul cost of old loader (local rebuild).
- d. Maintenance costs of old loader over remaining life and new loader through life.
- e. Discounted cash flow of costs in each case, taking into account company tax.
- f. Reliability/availability of old versus new loader.

- g. Time taken to repair the old loader.
- h. Warranty on new loader.
- i. Possible operational improvements of new loader versus old.

24.2 Replace Option

24.2.1 New Ore Loader Costs

As a first step in our analysis we calculate the net present value of the life cycle costs of acquiring a new loader and maintaining it for 4 years. For this purpose we need data on the costs relating to the acquisition of a new loader, the maintenance costs, and the disposal cost. The data shown in Fig. 24.2 have been estimated for the acquisition, maintenance, and disposal of a new loader over 4 years. The existing 4-year-old loader can be traded-in for \$150,000.

A cash flow diagram for these costs is shown in Fig. 24.3. These data are the same as that used in Chap. 5 to illustrate the calculation of the life cycle Net Present Value and Equivalent Annual Cost using the Excel functions NPV and PMT.

Fig. 24.2 New ore loader costs

New vehicle cost = \$780,000
 Trade-in allowance for existing loader = \$150,000
 Net acquisition cost = \$630,000

Year	Maintenance Costs, \$
1	60,000
2	90,000
3	135,000
4	180,000

Resale value at age 4 = \$150,000

Fig. 24.3 Cash flow diagram for new loader costs, \$k

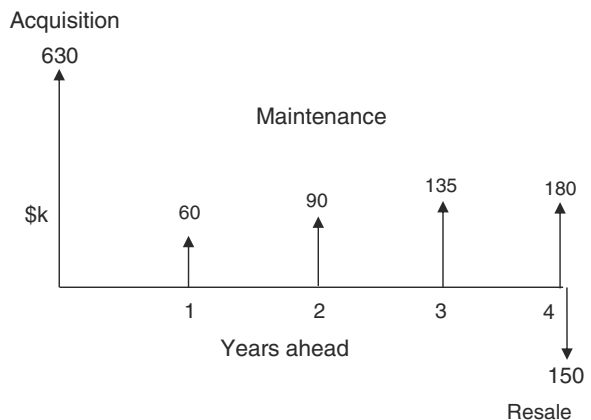
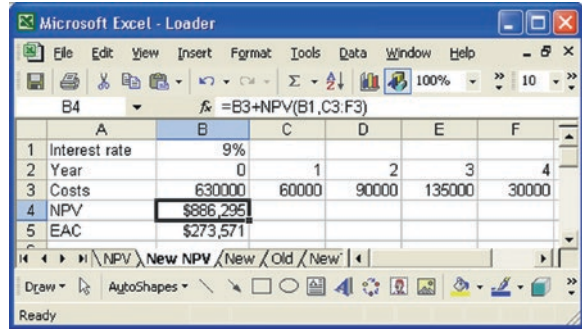

Fig. 24.4 Replace option—NPV and EAC of life cycle cost of new loader



24.3 New Loader Life Cycle NPV and EAC

The Net Present Value and the Equivalent Annual Cost of the life cycle costs of the loader can be calculated using the Excel NPV and PMT functions. The spreadsheet is shown at Fig. 24.4. The background to this is outlined in Chap. 5. The NPV for the life cycle cost of \$886,295 with the interest rate specified as 9 %, and the Equivalent Annual Cost is \$273,571 per year. Note that, although the spreadsheet gives the answer to an impressive degree of precision, the accuracy of the result depends on the accuracy of the various cost estimates, and we should therefore allow for a significant degree of variability in practice.

24.4 Overhaul Option

24.4.1 Old Ore Loader Costs

The next step toward our replace or overhaul decision is to estimate the costs of overhauling and maintaining the old loader over the 4-year period. These costs are shown in Table 24.1, where the costs are taken as occurring at the end of the years shown. The initial overhaul cost is \$240,000. The maintenance cost in year 1 is \$90,000. In year 2 the maintenance cost is \$135,000 and a second overhaul is required at the end of year 2/beginning of year 3 at a cost of \$240,000. The resale value of the loader at the end of year 4 is \$0.

Table 24.1 Old loader overhaul and maintenance costs

Year	Overhaul costs	Maintenance costs
0	240,000	
1		90,000
2	240,000	135,000
3		105,000
4		150,000

Fig. 24.5 Overhaul option—old loader cash flow

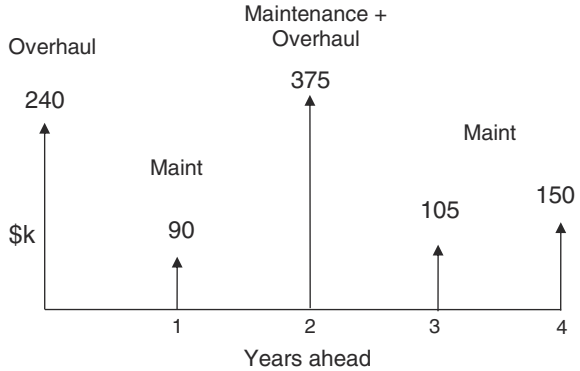
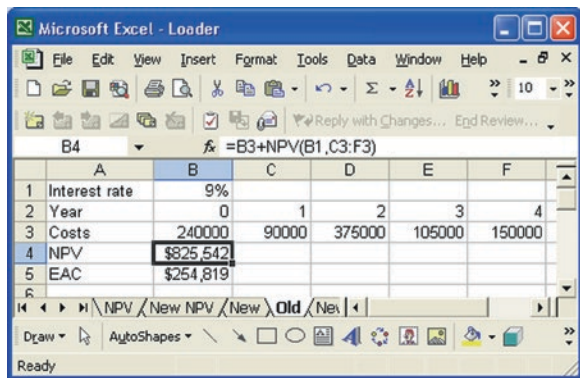

Fig. 24.6 Calculation of NPV and EAC for old loader option



The cash flow diagram for the option of overhauling the old loader is shown in Fig. 24.5.

The Excel calculation of the Net Present Value and Equivalent Annual Cost are shown in Fig. 24.6. Use is made of the Excel NPV and PMT functions. We see that the Net Present Value of costs for the old loader option is \$825,542, and the Equivalent Annual Cost is \$254,819 per year.

24.5 Cost Summary

The Equivalent Annual Cost for the old loader option and the corresponding result for the new loader option are summarized in Table 24.2.

Table 24.2 indicates that the old loader overhaul option is \$18,752 per year cheaper than the new loader, or replace, option. In the application on which this example is based, a decision was made initially to overhaul the old loader, but later, when the full implications of the choice were realized, it became clear that this decision was incorrect. The reasons for this will become apparent as we analyze the problem further.

Table 24.2 Cost comparison

New loader EAC	\$273,571 per year
Old loader EAC	\$254,819 per year
Saving	\$18,752 per year

24.6 Ore Loader Cost Analysis with Tax

The decision of whether to buy a new loader or to overhaul the old one was also influenced by the question of tax. If the work that we have referred to as an “overhaul” was classified as operating expense it would be immediately tax deductible. This would improve the cash flow of the overhaul option, compared to the replace option. Since the overhaul option has already been found to be cheaper before tax, this would further increase the advantage of the overhaul option after tax.

This question of OPEX or CAPEX expenditure can be something of a gray area. Repairs or overhauls carried out as part of the normal life cycle of an equipment are generally regarded as operating costs. But a major overhaul aimed at rejuvenating an equipment and hence, increasing its capital value beyond that which is normal for an item of the given age, is regarded as a capital expense. The book value should be revised upwards and the depreciation regime should be adjusted.

We now consider how the after tax costs will work out if the overhaul is regarded as a maintenance cost, which is tax deductible in the current year.

24.6.1 “Replace” Option with Tax

We illustrate the application of tax credits by continuing the replace or overhaul analysis relating to the ore loader. The adjusted cash flows are based on tax credits in the manner indicated in Fig. 23.9. The cost analysis for the Replace Option is shown in Fig. 24.7.

The effective life of the loader has been given as 5 years for depreciation purposes. Straight line depreciation is used. The annual depreciation is shown in row 6 of the spreadsheet. The depreciation tax credits are shown in row 7 and the maintenance tax credits in row 9. To determine the tax on resale, the book value, or Written Down Value (WDV) is calculated and is shown at B10 for the original old vehicle and at F10 for the acquired vehicle. The tax on resale is shown at B11 and F11.

The costs year by year are then calculated as shown in row 12 and the Net Present Value of the costs, and the Equivalent Annual Cost are shown at B13 and B14, respectively. We see that the NPV for the Replace option allowing for tax credits is \$622,833 and the EAC is \$192,249 per year.

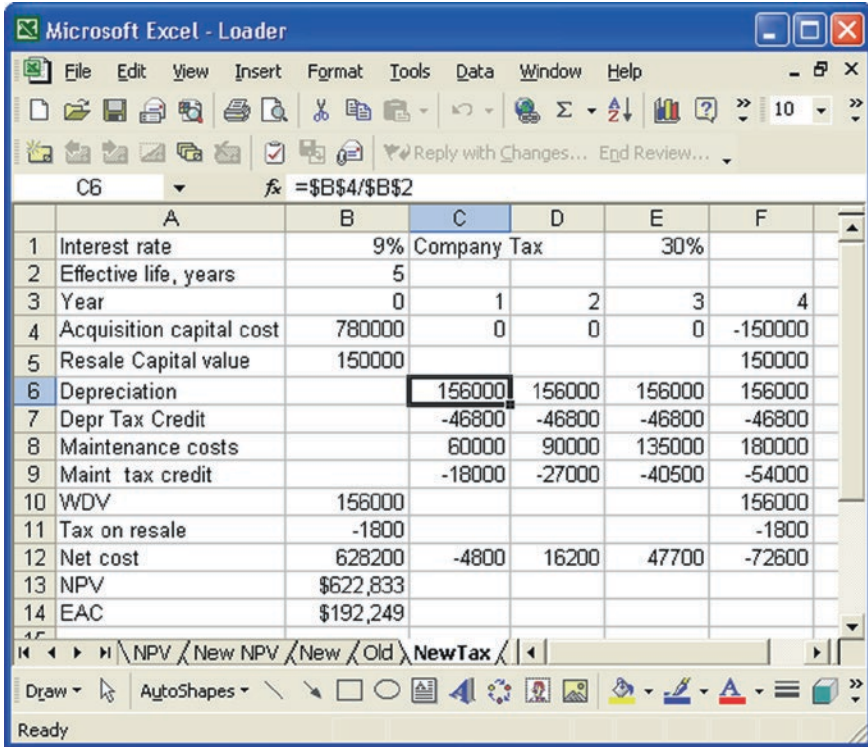

Fig. 24.7 New loader option—cost analysis with tax credits

24.6.2 “Overhaul” Option with Tax

For the option of overhauling the old loader the cost analysis with tax credits is shown in Fig. 24.8.

The maintenance tax credits appear in row 4. There is 1 year of depreciation remaining as the loader is 4-years old at the start and this is shown in cell C6. The net present value of costs over the 4-year period is \$534,944, cell B8, and the equivalent annual cost is \$165,120, cell B9. The value of the saving, as an equivalent annual cost, is given by the difference between the EACs shown in cell B14 of Fig. 24.7 and cell B9 of Fig. 24.8. The saving is shown at cell B10 of Fig. 24.8 and is \$27,129 per year. This result is also summarized in Fig. 24.9.

24.6.3 Loader Initial Policy Decision

The initial decision taken by the mining company in the replace versus overhaul issue was to overhaul the old loader. This was based on the cost comparisons indicated in Fig. 24.8.

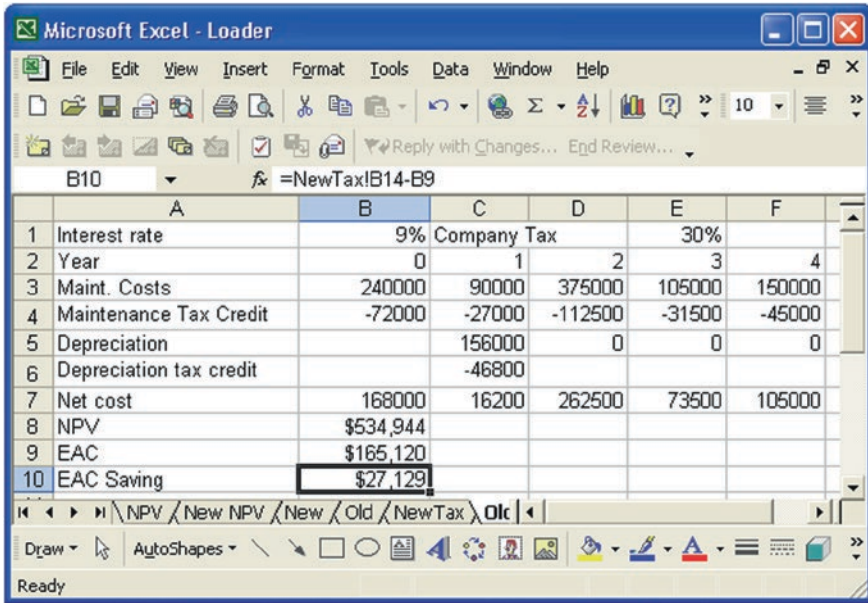

Fig. 24.8 Old loader option—cost analysis with tax credits

Fig. 24.9 Old loader savings after tax

New Loader EAC	\$192,249/yr
Old Loader EAC	\$165,120/yr
Saving	\$27,129/yr

24.7 Availability and Reliability

Although the costings indicated in favor of overhauling the old loader, the assumptions on which this was based turned out to be overoptimistic.

After experiencing one overhaul, the policy was changed for future loaders, and the loaders were subsequently replaced at age 4 years. The main reason for the change was the loss of availability while the old loaders were being overhauled. Initially it was assumed that the overhaul could be completed during the 2-week annual shutdown, but in fact further delays occurred resulting in an extra week of production losses which could not be made up. Also, the overhauled vehicles had no warranty cover, they were less reliable than new ones, and did not offer various design improvements that the manufacturer had built into later models. These factors more than offset the savings from overhauling the old vehicles. The saving in Fig. 24.8 of \$27,129 per year is less than the sales value of the metal moved in one working day by a loader.

24.7.1 Replace/Overhaul Ore Loader Conclusion

The conclusion of the Overhaul/Replace decision analysis for the loaders was that the loaders should be replaced rather than overhauled. The initial cost analysis did not make sufficient allowance for the time required to complete the overhaul or for the poorer reliability, availability, and reduced performance of the overhauled loaders when compared with the latest models. This highlighted the need to combine financial analysis with an overall view of the operational requirements.

24.8 Exercises

24.8.1 Standby Generator Exercise

A company is to install a standby generator in a certain location, at which it is required for 5 years. The initial capital cost is \$75,000 and the annual routine maintenance cost is \$2,500. The annual unscheduled maintenance cost has been estimated at an average value of \$3,500 per year. The value of the generator at the end of 5 years is estimated at \$40,000.

The company wishes to ascertain an equivalent annual cost as a basis for charging out the generator. Running expenses are additional and are not included at this point. The cost of capital advised by the finance department for this application is 9 %.

Calculate:

- (a) the equivalent annual cost of providing the generator,
- (b) the NPV of this cost.
- (c) If the company rents the generator out at \$30,000 per year, how much profit will it make in total?

Answers: (a) \$18,598 per year. (b) \$72,341. (c) \$44,350 (npv).

24.8.2 Solar or Diesel Power Exercise

Two options are being considered for providing electric power to a remote site. Estimate the life cycle cost of each option. Use discounted cash flow at 7 %. Which system would benefit if interest rates rose/fell? Which system is the cheapest at zero interest rate? The government wishes to encourage the installation of solar systems. How much upfront subsidy will it need to provide in order to make the solar system cost competitive over a long-term future?

Option 1: Solar Power

- (a) Acquisition and installation cost of all items excluding batteries. \$90,000
Life of Items (a) 15 years
- (b) Acquisition and installation cost of batteries (deep cycle). \$60,000
Life of Items (b) 7 years
- (c) Operating and maintenance cost per year for solar power system. \$3,000

Option 2: Diesel Power

- (a) Acquisition and installation cost. \$50,000
- (b) Overhaul cost after 10 years. \$20,000
- (c) Life of diesel system. 20 years
- (d) Operating and maintenance cost per year for diesel system. \$12,000

The solution to this exercise has been given using the discount factors and annuity factors directly, rather than through Excel.

The following discounted cash flow factors are given for an interest rate of 7 %:

Years	Discount factor	Annuity factor
7	0.6227	5.3893
10	0.5083	7.0236
15	0.3878	9.1079
20	0.2765	10.5940

24.9 Exercise Solutions**24.9.1 Standby Generator Exercise Solution**

The solution is obtained using Excel to carry out the calculation. Figure 24.10 shows the spreadsheet. Notes on the additional Excel features used in this exercise are given at the end of the solution.

For question (a) we need to calculate equivalent annual cost for the various cost components.

1. Convert the initial capital cost of \$75,000 into an EAC over the 5-year period by using the PMT function. The result is shown at cell C4 and is \$19,282 per year.
2. Convert the terminal value into an EAC by using the PMT function with the option of the cost being at the end of the time period. The result is shown at cell C5 and is $-\$6,683$ per year. (Note: this use of the PMT function is illustrated separately at the end of this exercise.)
3. The maintenance costs are already annual costs, and their total is:

$$\$2,500 + \$3,500 = \$6,000 \text{ per year.}$$

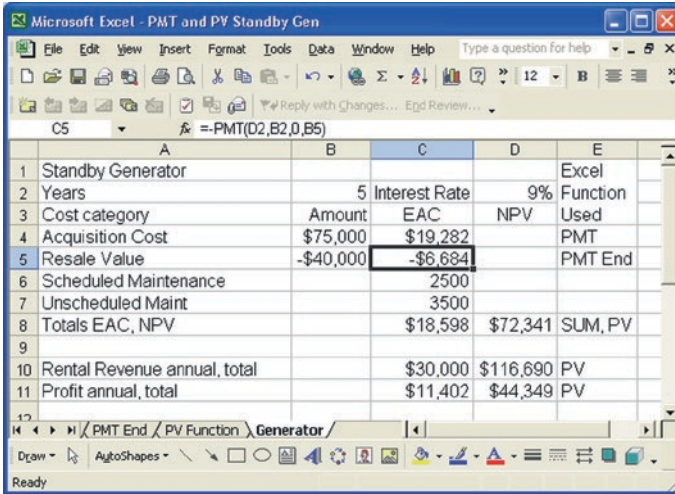

Fig. 24.10 Standby generator Excel solution

Add the amounts from steps 1, 2, and 3 to get the total cost (the terminal value is negative):

$$\begin{array}{r}
 \text{Initial capital EAC} = 19,282 \text{ \$ per year} \\
 \text{Terminalvalue EAC} = -6,683 \text{ \$ per year} \\
 \text{Maintenance EAC} = 6,000 \text{ \$ per year} \\
 \hline
 \text{Total EAC} = 18,599 \text{ \$ per year}
 \end{array}$$

This result of \$18,599 per year is shown at cell C8.

For question (b) we need to convert the EAC of \$18,599 per year into an NPV. This can be done using the Excel function PV, with the result shown at cell D8, that is, \$72,341.

For question (c), if rent is \$30,000 p.a. the net revenue is $30,000 - 18,599 = 11,401$ p.a.

The total NPV of net revenue is calculated using the PV fuction at cell D11 and is \$44,346.

24.9.1.1 The Excel Function PV

The Excel function PV calculates the net present value of a uniform series of annual payments. Figure 24.11 shows an example of the use of the Excel PV function. In a certain application there is an annual scheduled maintenance cost of \$2,500 incurred each year for 5 years. We wish to calculate the net present value of this maintenance cost at an interest rate of 9 %. The annual cost is at B6, the

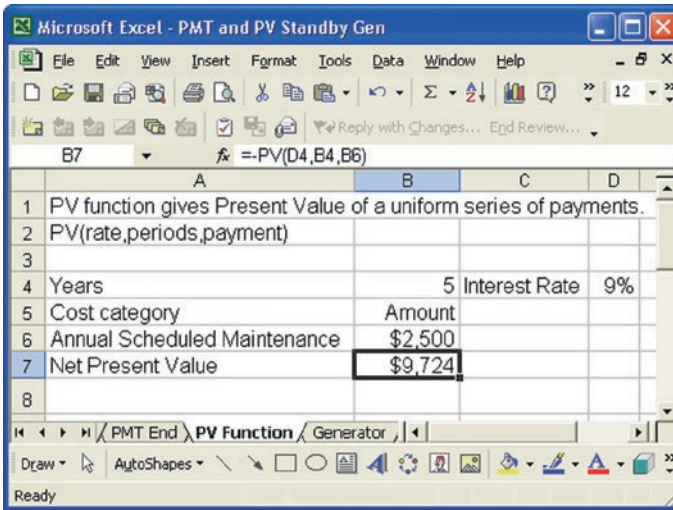

Fig. 24.11 The Excel function PV

number of years at B4, and the interest rate at D4. The function PV is used in cell B7 to calculate the net present value of these maintenance costs. The function field shows the use of the Excel function PV. The minus sign in front of the function gives the PV the same sign as the maintenance cost.

24.9.1.2 Payment or Cost at End

The PMT function has an option for calculating the equivalent annual cost of a payment made at the end of the last period, rather than at the beginning of the first period. This is useful if we require the EAC of a terminal or resale value. An example in which a resale value of \$40,000 received in 5 years time is converted to an equivalent annual cost at 9 % is shown in Fig. 24.12 at cell C5 and in Fig. 24.12 at cell C7.

24.9.2 Solar or Diesel Power Exercise Solution

This exercise illustrates the use of the Equivalent Annual Cost (EAC) in comparing costs for items with different life cycle durations. For example, the solar cells have a life of 15 years but the batteries have a life of 7 years. Expressing both costs as EACs provides a basis for comparisons.

In this solution, the discount factors and annuity factors have been used directly, rather than through Excel, so as to show the principles involved.

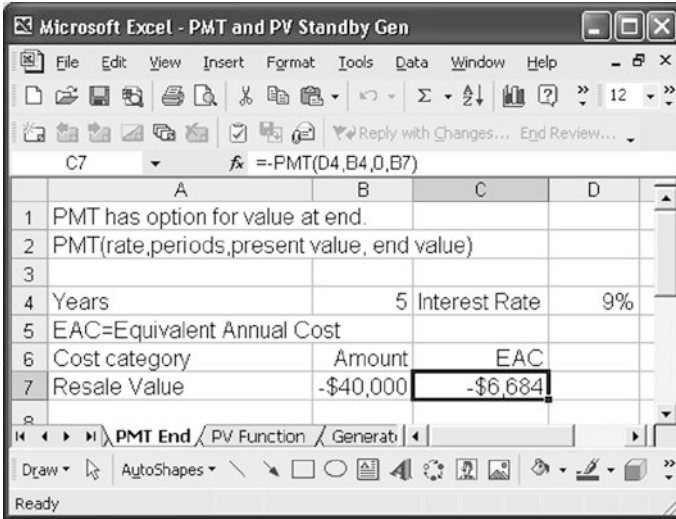

Fig. 24.12 PMT function with payment at end

Option 1: *Solar Power*

- (a) Acquisition \$90,000, 15 years $EAC = 90,000/9.1079 = 9,882$
- (b) Batteries \$60,000, 7 years $EAC = 60,000/5.3893 = 11,133$
- (c) O & M Cost = 3,000
- Total \$/year = 24,015

Option 2: *Diesel Power*

- (a) Calculate NPV over 20 year life cycle :
 - (b) $NPV = \text{Acquisition} + 10 \text{ year discount factor} \times \text{overhaul cost}$
 $= 50,000 + 0.5083 \times 20,000 = \$60,166$
 - (c) $EAC = NPV/AN \text{ for 20 years}$
 $= 60,166/10.5940 = \$5,679 \text{ per year}$
 - (d) O & M Cost = 12,000
 - Total \$/year = 17,679

Solar NPV to infinity at 7 % = $EAC/r = 24,015/0.07 = \$343,071$
 Diesel NPV to infinity at 7 % = $EAC/r = 17,679/0.07 = \$252,557$

Increasing the interest rate would favor diesel because it has fewer upfront costs. Lowering the interest rate would favor solar power, but diesel is still cheaper at zero interest.

Solution at Zero Interest

Option 1: *Solar Power*

$$\begin{aligned}
 \text{(a) Acquisition } \$90,000, 15 \text{ years EAC} &= 90,000/15 = 6,000 \\
 \text{(b) Batteries } \$60,000, 7 \text{ years EAC} &= 60,000/7 = 8,571 \\
 \text{(c) O\&M Cost} &= \underline{3,000} \\
 \text{Total } \$/\text{year} &= 17,751
 \end{aligned}$$

Option 2: *Diesel Power*

$$\begin{aligned}
 \text{(a) EAC} &= \text{NPV}/20 \\
 &= 70,000/20 = 3,500 \\
 \text{(b) O \& M Cost} &= \underline{12,000} \\
 \text{Total } \$/\text{year} &= 15,500
 \end{aligned}$$

In this case diesel power is cheaper at all interest values. In some applications the optimum policy may vary with the interest rate.

Diesel power also is not dependent on the sun shining, so it is more reliable in a remote location with no alternative supply.

Chapter 25

Economic Life

Abstract The aim of this chapter is to present the concept of economic life and to discuss the role it plays in asset management decisions relating to life cycle costing and replacement decisions. *Outcomes* After reading this chapter you will know what is meant by economic life and how it can be estimated from cost data.

25.1 Economic Life Concept

The economic life of an item is the age beyond which it is not worth keeping it from a cost point of view. It is the life duration which minimizes its cost per unit time, or, allowing for discounted cash flow, the equivalent annual cost.

From a practical point of view, “economic life” is a somewhat idealized concept, as many factors can influence the actual decision to replace an item. These factors are considered in detail in the chapter on equipment replacement. However, it is worthwhile to consider the concept of economic life as it forms a basis that underlies replacement analysis.

Tax authorities assign “effective lives” to items. These lives are based on a perceived average age to which we would normally expect an item to last—which is, in effect, an average economic life. In life cycle costing, the length of life of an item may be based on technical judgment, or on more formal cost analysis. In principle, the life chosen should be the economic life.

25.2 Economic Life Example

The following example contains only the simplest costs, so that we can concentrate on the cost structure. Issues such as resale, discounting, and tax are disregarded in this example, but are considered later.

Table 25.1 Vehicle cost data

Acquisition cost	Year	1	2	3	4
\$300,000	O&M Cost, (\$)	10,000	25,000	45,000	150,000

A certain type of vehicle is purchased for an acquisition cost of \$300,000. The operating and maintenance (O&M) costs in years 1, 2, 3, 4 of the life of the vehicle, are as shown in Table 25.1. Calculate the economic life.

25.2.1 Hand Calculation

To determine the economic life we calculate the cost per year for each of the options of 1, 2, 3, or 4-year life cycles. The economic life will be the cycle length which gives the lowest cost per year.

For replacement at age Y , the total cost, C , is given by:

$$C = \text{Acquisition cost} + \text{Cumulative O\&M cost}$$

And the cost per year is C/Y .

For example, if the policy is to replace the vehicle at age 1 year. The total cost over the life of the vehicle, C_1 , is given by:

$$\begin{aligned} C_1 &= \text{Acquisition cost} + \text{O\&M costs year 1} \\ &= 300,000 + 10,000 = 310,000 \end{aligned}$$

The cost per year for this policy is therefore \$310,000.

If the policy is to replace the vehicle at age 2 years, the total cost over the life of the vehicle, C_2 , is given by:

$$\begin{aligned} C_2 &= \text{Acquisition cost} + \text{O\&M costs year 1} + \text{O\&M costs year 2} \\ &= 300,000 + 10,000 + 25,000 = 335,000 \end{aligned}$$

The \$335,000 is the cost incurred over a 2-year period and to get the average cost per year we must divide by 2.

Thus the cost per year is $335,000/2 = 167,500$.

Similarly, for replacement at age 3 we have:

$$C_3/\text{yr} = (300,000 + 10,000 + 25,000 + 45,000)/3 = 126,667$$

and for replacement at age 4 we have:

$$\begin{aligned} C_4/\text{yr} &= (300,000 + 10,000 + 25,000 + 45,000 + 150,000)/4 \\ &= 132,500 \end{aligned}$$

These results are summarized in Table 25.2. We see that the lowest cost per year occurs when the replacement age is 3 years, so this is the economic life.

Table 25.2 Economic life calculation

Replacement age, years	1	2	3 (Economic life)	4
Cost per year	310,000	167,500	126,667	132,500

25.2.2 Spreadsheet Calculation

Table 25.3 shows these calculations in a spreadsheet. The acquisition cost is at cell B2. The O&M costs are in row 3. The cumulative O&M costs are in Row 4. The total cumulative costs including the acquisition cost are in Row 5. Row 6, columns C to F, show the costs per year for the 1, 2, 3, and 4-year cycles, respectively. The results are the same as in Table 25.2 and confirm that the economic life is 3 years. The cost per year of \$126,667 is shown at cell E6.

Figure 25.1 shows the cost per year (from Row 6 of Table 25.3) as a graph. We see graphically that the economic life occurs when the cost per year is a minimum at age 3.

Figure 25.2 shows the total cumulative cost (from Row 5 of Table 25.3) as a graph. The radius vector has been drawn in, showing that the economic life occurs when the marginal increase in cumulative cost exceeds the average life cycle cost per year. As expected, the economic life occurs at age 3.

Table 25.3 Economic life analysis example

	A	B	C	D	E	F
1	Year, Y	0	1	2	3	4
2	Acquisition cost, A	30,0000				
3	O&M cost EOY, M		10,000	25,000	45,000	150,000
4	O&M cumulative, T		10,000	35,000	80,000	230,000
5	Total cost C = A + T		310,000	335,000	380,000	530,000
6	Cost per year C/Y		310,000	167,500	126,667	132,500
7	O&M = operating and main cost in year			EOY = end of year		

Fig. 25.1 Cost per year and economic life

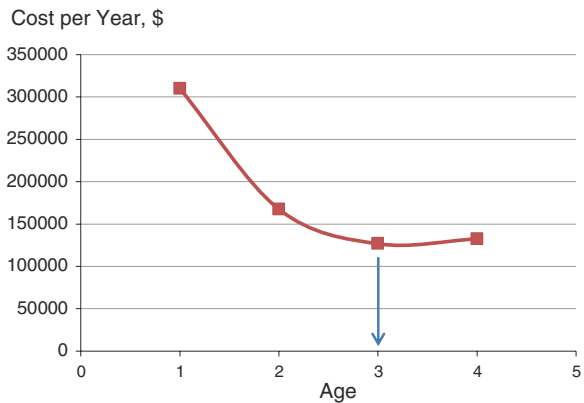

Fig. 25.2 Cumulative cost and economic life

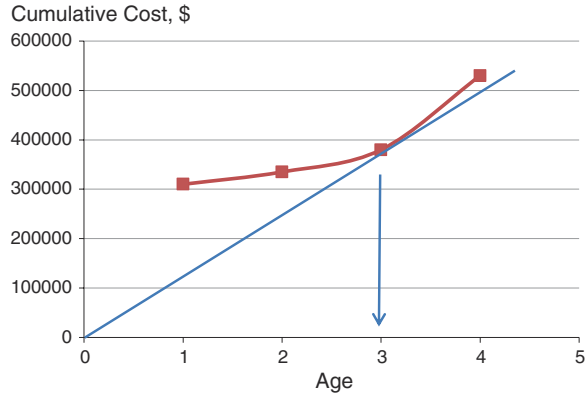

Fig. 25.3 Annual maintenance cost and life cycle average cost

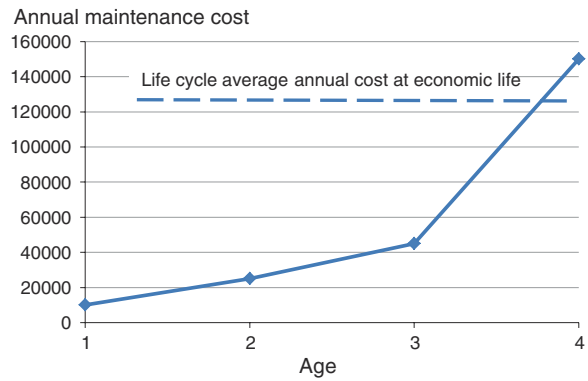

Figure 25.2 illustrates the point that the economic life occurs when the marginal cost of keeping the item exceeds the average cost to date.

Figure 25.3 shows the annual O&M cost (Row 3 of Table 25.3) plotted against age. The dotted line is the life cycle average cost per year at the economic life. We see that in year 4 the annual maintenance cost exceeds the life cycle average cost per year at the economic life. This is another way of presenting the same result, namely that when the annual maintenance cost exceeds the life cycle average cost per year, then the economic life has been passed.

In replacement problems, the marginal cost refers to an existing item and the average cost per year is an estimate for the annualized life cycle cost of a potential replacement item.

25.2.3 Economic Life with Discounting

When costs are discounted and we have life cycles of different lengths we base our comparisons on equivalent annual cost, EAC. We therefore need to calculate the

EAC for each possible cycle length, 1, 2, 3, or 4 year. Figure 25.3 shows data for an example that includes resale values.

Let replacement occur at age n . Let r be the interest rate and p the discount factor. Then the net present value of the cost of the vehicle over n years is:

$$NPV = A + \sum_{i=1}^n p^i M_i - p^n S_n$$

and the equivalent annual cost is:

$$EAC = r * NPV / (1 - p^n) \tag{25.1}$$

Figure 25.5 shows schematically the cash flow diagrams as they apply for a 3-year and a for a 4-year life cycle. From these cash flows we calculate the Equivalent Annual Costs for each cycle, using the appropriate interest rate, and then compare the EACs. The cycle length with the lowest EAC indicates the economic life.

For the data of Fig. 25.4, 25.6 shows the calculation of the equivalent annual costs of the four life cycle options, with the interest rate at 15 %. The Excel functions NPV and PMT are used in the spreadsheet. By inspection, we see that the minimum cost replacement age is 3 years, the EAC being \$130,364 per year.

Acquisition cost	Year, i	1	2	3	4
A=\$300,000	O & M Cost, \$M	30,000	45,000	65,000	117,500
	Trade-in Value \$\$	235,000	190,000	160,000	127,500

Fig. 25.4 Vehicle life cycle cost data

Fig. 25.5 Cash flows and EACs for 3- and 4-year life cycles

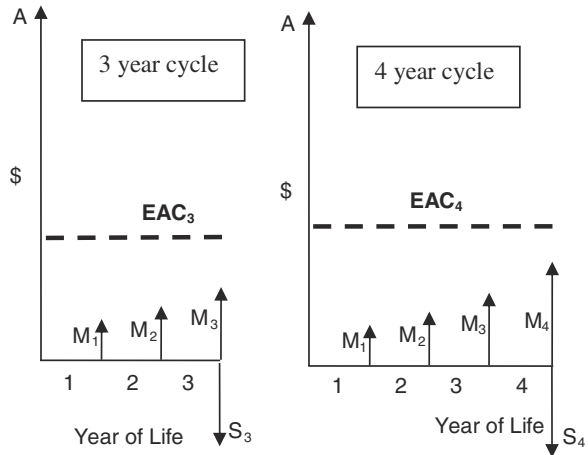

The economic life may vary with the value of the interest rate. As a general principle, raising the interest rate has the effect of making it optimal to postpone replacement. This is an example of how raising the interest rate dampens economic activity. However, solutions to problems of this type are not always sensitive to moderate changes in the interest rate, or, indeed to other data items. One of the potential applications of this type of model is to test the sensitivity of the solution to changes in the data.

25.2.4 Economic Life with Discounting and Tax

Tax can be allowed for using the tax credit analysis described in Sect. 23.6. Figure 25.7 shows this in spreadsheet form. Depreciation is based on the declining balance method at a rate of 18.75 % per year and the company tax is at 30 %. The optimal life cycle remains at 3 years, so that in this case company tax has not affected the practical decision (Fig. 25.7).

25.3 Exercises

25.3.1 Self-Assessment Exercise

1. What is meant by the economic life of an item?
2. What is the relationship between the economic life and the marginal cost of maintenance?
3. How is the economic life calculated:
 - a. Undiscounted case
 - b. Discounted case

	A	B	C	D	E	F
1	Year, Y	0	1	2	3	4
2	Acquisition cost, A	\$300,000				
3	O&M Cost EOY, M		\$30,000	\$45,000	\$65,000	\$117,500
4	Resale value EOY, R		-\$235,000	-\$190,000	-\$160,000	-\$127,500
5	Interest rate %	15%				
6	NPV of Cumul O&M		\$26,087	\$60,113	\$102,852	\$170,033
7	PV of Resale Value		-\$204,348	-\$143,667	-\$105,203	-\$72,899
8	NPV of Cumul Cost		\$121,739	\$216,446	\$297,649	\$397,134
9	EAC		\$140,000	\$133,140	\$130,364	\$139,102
10	NPV=Net Present value	EAC=Equivalent Annual Cost			PV=Present Value	

Fig. 25.6 Economic life analysis with discounting

	A	B	C	D	E	F
1	Year	0	1	2	3	4
2	Acquisition cost	300000				
3	O&M Cost EOY		30000	45000	65000	117500
4	Resale value EOY		235000	190000	160000	127500
5	Interest rate %	15%				
6						
7	NPV of Cumul O&M		26087	60113	102852	170033
8	NPV of Resale Value		204348	143667	105203	72899
9	NPV of Cumul Cost		121739	216446	297649	397134
10	EAC		\$140,000	\$133,140	\$130,364	\$139,102
11						
12	Depreciation rate %		18.75	0.8125		
13	WDV at end of yr		243750	198047	160913	130742
14	Depreciation in yr		56250	45703	37134	30171
15	Company tax rate%		30			
16	Tax credit OMD EOY		25875	27211	30640	44301
17	O&M - tax credit		4125	17789	34360	73199
18	NPV cumul after tax OMD		3587	17038	39630	81482
19						
20	Tax credit on resale EOY		2625	2414	274	973
21	Resale + tax credit		237625	192414	160274	128473
22	NPV after tax RS		206630	145493	105383	73455
23						
24	NPV after tax		96957	171545	234248	308027
25	EAC after tax		111500	105520	102595	107891
26						
27	BOY = Beginning of Year					
28	OMD = Operating+Maint-Depreciation.					
29	RS = Resale or Trade-in value EOY					
30	WDV = Written Down Value					

Fig. 25.7 Economic life analysis with depreciation and tax

25.3.2 Self-Assessment Exercise Solution

1. *What is meant by the economic life of an item?*
 The economic life of an item is the age beyond which it is not worth keeping an item from a cost point of view. It is the life duration which minimizes its cost per unit time, or, allowing for discounted cash flow, the equivalent annual cost.
2. *What is the relationship between the economic life and the marginal cost of maintenance?*
 The economic life occurs when the marginal annual cost rate for maintenance equals the average annual cost rate over the life cycle.

3. *How is the economic life calculated:*

a. *Undiscounted case*

For life cycles of a relevant range of lengths, in the undiscounted case we calculate the total cost of acquisition, operation, and maintenance and divide by the length of the life cycle to obtain a cost per unit time. The life cycle with the lowest cost per unit time determines the economic life.

b. *Discounted case*

For life cycles of a relevant range of lengths, in the discounted case we calculate the total net present value of the cost of acquisition, operation, and maintenance and then calculate the equivalent annual cost for the life cycle. The life cycle with the lowest equivalent annual cost determines the economic life.

Chapter 26

Equipment Replacement Decisions

Abstract The aim of this chapter is to present the factors involved in decisions relating to the replacement of equipment, and to show how replacement decisions can be analyzed. Various scenarios relating to replacement analysis based on increasing maintenance cost with age presented. The use of spend-limits as a replacement control mechanism is presented and the role of risk analysis in replacement decisions. Factors involved in the replacement of *linear assets* such as pipelines, power lines, roads, and rail lines are discussed and component replacement policies. *Outcomes* After reading this chapter you will be aware of the factors which influence equipment replacement decisions. You will know that financial analysis of replacement policy is based on comparing the estimated future costs of the existing equipment with that of a challenger. You will know about spend-limits and their role in the setting of replacement policies and how risk might be taken into account. You will also be aware of factors involved in component replacement decisions.

26.1 Replacement Planning

H.M. Barker in his book “Camels and the Outback” reports that in 1923 he was carting material from Nullagine to Marble bar in Western Australia when his camel wagon, for which the 90 km journey took 3 days, was overtaken by a motor lorry—the first one in the region. He thought that the lorry was a novelty that would never seriously compete with his camels, but by the time he got to Marble Bar the lorry had passed him three more times, and the mine manager had sent word that his wagon would not be required any more.

Organizations need a systematic approach to the development of replacement plans. Flexibility must be retained as priorities may change, but a backlog of replacements should not build up to a point where losses or serious risks are occurring. The magnitude of such losses or risks is often a more important factor than the achievement of precise cost optimality in replacement planning.

Those who wish to win friends and influence people never bring bad news, as the reaction of senior people is often to shoot the messenger. Replacing existing equipment is rarely the glamour side of business management and this creates a dilemma for asset managers whose job involves replacement planning.

The best approach is to have a rolling plan in which all forward replacement requirements are indicated well in advance, the costs are built into the capital budget, and the acquisition lead times are allowed for. The asset manager can then become an occasional bringer of good news if some items turn out to be in better condition than originally anticipated as their forecast replacement date approaches. Risk assessments should be included, so as to provide senior management with information on relative priorities. However, it is important to avoid crying wolf or being too smart after event. Putting forward reasoned proposals with an associated risk assessment will produce the best results.

Lack of sufficient focus on equipment condition within an organization can lead to a procrastination driven tragedy. The asset manager requests finance for equipment replacement but is asked to prove that it is essential. This is hard to substantiate, the money is not forthcoming, and eventually a significant failure occurs. The asset manager is then criticized for “not warning” senior management about the problem. A more extreme version is the asset death spiral mentioned in an early chapter. In that scenario, maintenance and replacement budgets and technical infrastructure are reduced creating short-term savings. Routine maintenance becomes minimal or nonexistent. Eventually a catastrophe occurs.

26.2 Reasons for Equipment Replacement

As equipment ages there are many reasons why we eventually need to replace it. Key factors influencing replacement decisions include the following; in many cases more than one factor will come into play at the same time.

Operational reasons

- Reduced performance through degradation or relative to newer equipment types
- Reduced availability
- Reduced reliability

Technical reasons

- Equipment not repairable at all
- Equipment not logistically supportable, e.g., spares not available, repair facilities not available
- Increased risk of failure, long term deterioration e.g., corrosion, fatigue, insulation deterioration, with associated risk-costs

Commercial reasons

- Operationally obsolete
- Capacity needs have changed, increased or decreased
- Operating value low compared with new
- Operating costs high compared with new
- Maintenance costs high compared with new
- Item requires repair, the cost of which is unlikely to be recovered.

Regulatory reasons

- Safety or health issues
- Environmental issues
- Government regulator’s rules favor replacement because they are based on book value which is now low or zero
- Technical regulations changed, e.g., increased fuel efficiency mandated.

Figure 26.1 shows a flowchart covering the logic of replacement decisions. The box at the top left summarizes physical or operational reasons for equipment replacement. Financial issues may include economic life, the spend-limit considered in a later section, and risk-cost, that is the probability of incurring an excessive cost as a result of a risk eventuating. In some cases it may be possible to redeploy or refurbish equipment and these possibilities are covered in the flowchart. The flowchart was developed for items with a focus on service provision and cost minimization, rather than on profit generation. In a profit focused case, net operating value would be an issue, rather than cost alone.

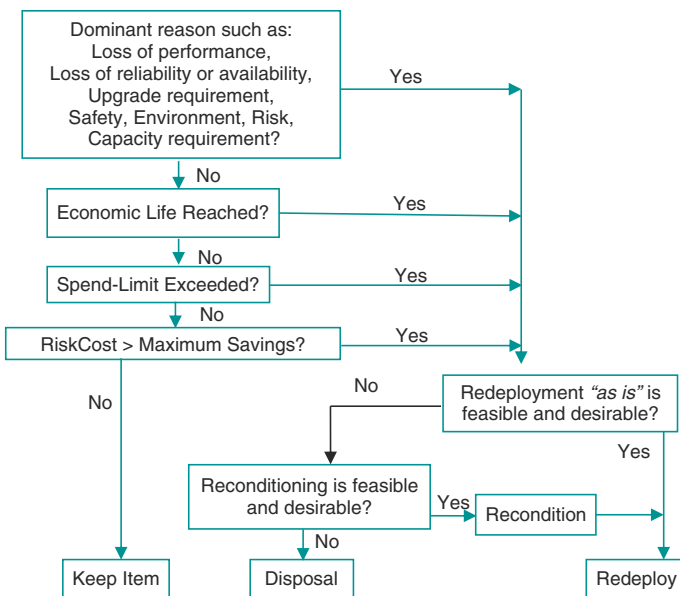

Fig. 26.1 Replacement analysis flowchart

26.3 Technical Assessment

An awareness of criticality and the identification of high risk items is important in the overview of technical condition and replacement analysis. The condition of the existing equipment, particularly in regard to things that deteriorate with age and are not readily remedied, should be monitored. Condition monitoring techniques should be deployed to obtain indications of equipment state, and this can give an advance indication of when replacement will be required. Factors to be considered include corrosion, insulation deterioration, embrittlement of plastics, moisture penetration, fatigue, erosion, wood rot, surface degradation, cracking, and movement of structures.

The performance of existing equipment should be monitored in regard to operational efficiency, reliability, availability, and maintainability, and the results assessed in relation to the needs of the organization. In some cases, older equipment can be deployed to less critical tasks or to standby roles rather than being discarded. Degradation in performance or in regard to risk of failure often forms the basis for equipment replacement.

26.4 Data Analysis

Replacement decisions are generally based on assessment of changes in performance, reliability, and risk as equipment ages. Data relating to these factors are often present in the form of operating and maintenance records, but in order to use this data, suitable reports need to be generated from it. These should highlight changes in operating performance, failure rate, and maintenance costs, forming the basis for sound decisions for replacement of equipment. Experience and gut feel can also play a role, but data analysis is the best approach.

26.5 Cost Analysis for Replacement

Whatever the reason for replacement of equipment, a supporting financial analysis will normally be required, and we now consider the types of analysis needed.

26.5.1 *Like-with-Like Replacement*

In the chapters on life cycle costing and economic life we considered life cycle-based cost analysis, and the determination of an equivalent annual cost (EAC) over the life cycle. In the case of like-with-like replacement, the economic life determined from that analysis provides the guideline for our replacement decision.

An important fact to recognize is the acquisition cost of a new item is always likely to be greater than the current year cost of keeping an old item; but to

minimize long-run costs we need to replace an old item when its current year costs exceed the *annualized* life cycle cost (EAC) of the *new* item, not the acquisition cost. This principle underlies all replacement cost analysis.

26.5.2 *Equivalent Annual Cost of the Challenger*

In practice, we are likely to find that we are making decisions about replacing equipment of an earlier type with equipment of a newer type. This may give rise to a need to replace for broader reasons than direct equipment cost, and these reasons have already been discussed. We now consider the case where the “competition” between existing equipment and new equipment is based on cost grounds.

We can refer to the existing equipment as the old equipment and to the potential replacement as the new equipment. Another form of nomenclature is to refer to the potential new equipment as the “challenger” and the existing equipment as the “defender”.

Consider a situation where we are considering buying a new car to replace an existing one. The new car is the challenger and the old car is the defender. The price of the challenger will be a factor in our decision, since if prices have tended lower, we will be likely to make the changeover sooner than if they have tended higher. In the current year, the acquisition price of the challenger will be almost sure to exceed the maintenance cost of the defender in that year, and if we based our comparison solely on the immediate year’s costs we might postpone our decision for a very long time. The correct approach is to consider the EAC of the challenger over its lifetime and compare this with the EAC of the defender over its *estimated remaining life*. This analysis requires us to make an estimate of the EAC of the challenger, so that life cycle costing analysis is required for the new equipment. Previous expenditure on the existing equipment is a sunk cost and not relevant to our decision. Indirectly though, previous expenditure may be a factor influencing the current condition of the existing equipment, which is a consideration.

26.5.3 *Steadily Increasing Cost Case*

If the cost of the old item increases steadily year by year, the decision to replace is based on comparing the cost of keeping the old item for one more year, as against the annualized cost of the new, or challenger, item. The annualized cost of the new item is the EAC, as estimated by life cycle costing.

The cost of the old item includes the maintenance cost, any decline in resale value, and costs associated with declining performance relative to a new item. For example, if the old item incurs relatively high down time we should include an estimate of the cost involved, compared with the corresponding lifetime average down time per year of the challenger.

Figure 26.2 illustrates the steadily increasing cost case. The “X” symbols represent the annual maintenance costs of the old item. The EAC of the new item is

Fig. 26.2 Replacement analysis—steadily increasing costs

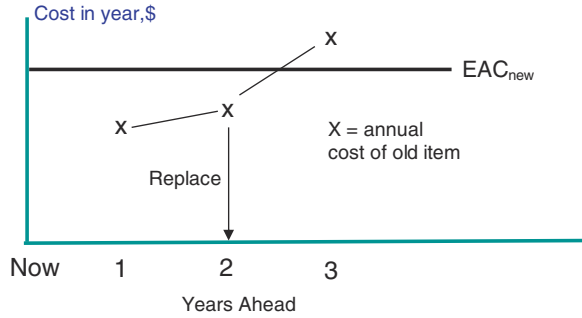
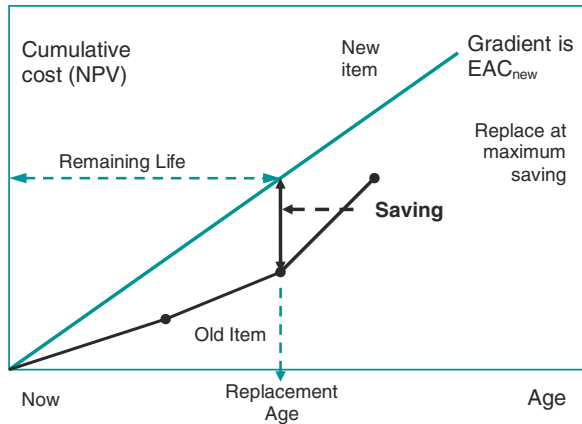

Fig. 26.3 Cumulative cost comparison



referred to as EAC_{new} . The old item should be replaced at the end of the second year from now, as in the third year ahead (and subsequently) the annual costs of the old item will exceed EAC_{new} .

26.5.4 Savings

Another way of representing the cost comparison is by means of a cumulative plot as shown in Fig. 26.3. The cumulative cost of the old item is the lower solid line. The upper solid line has gradient equal to the EAC of the new or challenger item. In the cumulative plot the gap between the “new” and “old” lines represents the savings accumulated by continuing to use the old item. In Fig. 26.3 the optimum replacement age is when the difference between the new and old lines is a maximum. The extent of the savings can be considered when assessing risk or other intangible aspects of the replacement option. Thus, if the total savings are quite small in relation to a possible risk, we may decide to replace before the theoretical minimum cost point.

As time goes by the origin of the graph shifts to the new “Now” and the potential savings from keeping the old item decrease, and ultimately disappear.

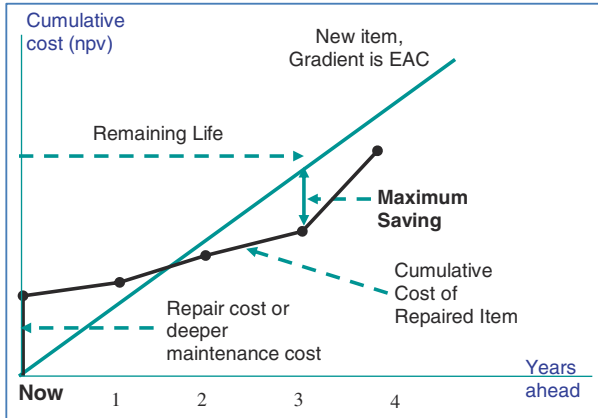

Fig. 26.4 Variable cost case

26.5.5 Unevenly Changing Cost Case

The cumulative plot analysis also covers the case where the cost of the old item does not increase steadily, but can vary, for example due to deeper maintenance taking place on a cyclic basis. In this case, the cost in the deeper maintenance year may be above the EAC of the new item, but then falls in the rest of the maintenance cycle. The point of maximum savings on the cumulative plot gives the optimal replacement age. The same analysis applies where a one-off significant repair is required now; or where a refurbishment that will subsequently lead to lower costs is being considered.

Figure 26.4 shows a case where an equipment requires a major repair now, and a forecast has been made of subsequent costs following repair. No costs are expected in year 1. In years 2, 3, and 4 costs are low initially but then gradually increase. In year 2, the cumulative cost curve for the old item (repaired item) falls below the cumulative cost line for the challenger (new) item yielding savings. The optimal remaining life occurs when the saving is a maximum. As shown, this occurs at year 3.

If the cumulative cost line of the repaired item does not fall below the new item line, then it is not worthwhile to carry out the major repair. This analysis can be used to indicate whether a proposed repair or refurbishment is financially worthwhile. The magnitude of the potential savings can be used as a judgment factor in deciding whether to undertake the repair, and in risk analysis.

26.6 Spend-Limits

We can sometimes find that excessive amounts are spent on uneconomic repairs unless rules preventing this are put in place. Such rules are known as spend-limit rules or repair-limit rules. A spend-limit is a limit on the amount which it

is permitted to spend on repair or refurbishment of an existing item. The value of a spend-limit will depend on the type of item, its age, and the replacement options and costs. The operation of a spend-limit system depends on the availability of replacement items. As such it is typically applicable to items of intermediate value, such as vehicles, radio sets, common user motors, or pumps, where there is access to a replacement pool.

Logically, no more should be spent on the repair of an item than the item is worth. As a quick guide, the book value of an item acts as an upper limit on how much to spend on repair at any point. If the book value does not accurately reflect the value of the item to the business, the spend-limit should be the maximum savings from retaining the old equipment, as shown in Figs. 26.3 or 26.4. An item that requires a repair whose cost exceeds its spend-limit should be replaced.

The “spend-limit” concept can be illustrated by the following common application. If a vehicle incurs accident damage which exceeds its second-hand value, then the company that insures the vehicle will normally specify that the vehicle is written off and is not repaired. The second-hand value acts as a limit on the amount that is worthwhile spending on the repair. This reflects a basic principle that no more should be spent on the repair of an item than the item is worth after repair. The value after repair is a “spend-limit” for an item.

26.6.1 Spend-Limit Example

A bus company has a number of old buses which are used only on days of high demand. Repair/replacement decisions are controlled by spend-limits. The spend-limit for old buses is set to a level which allows buses with no problems or requiring very minor repairs to be retained, but repairs involving major assembly replacement or major bodywork are ruled out.

26.7 Risk with Ageing Equipment

Equipment replacement decisions often need to take account of risk. Average cost per unit time will decrease initially as the acquisition cost is amortized, as shown in Fig. 26.5. But then, rather than tending slowly upwards, there may be a sudden jump in costs due to a major failure. This type of behavior occurs with items whose maintenance costs are low relative to their capital cost, but which can

Fig. 26.5 Long life equipment with risk

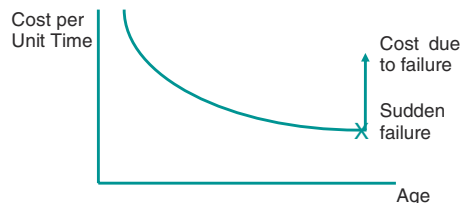

experience catastrophic failure. Power transformers provide an example. In such cases it is essential to take account of risk as equipment ages.

Senior management should be involved in the assessment of the risks and consequences arising in any such situation, as their estimate is likely to be the best available, and their ability to make a sound judgmental decision in terms of the business as a whole may save needless and possibly inaccurate analysis.

Where suitable data is available we can estimate levels of risk. For example, an electricity transmission company with complete data on all failure and maintenance history of its transformers estimated the probability of major failure related to age and to other measures of transformer utilization and condition. From this it was able to draw up guidelines for preventive replacement policies which kept the probability of major failure to low levels. It is generally not possible to eliminate all risk. Where less data is available we may need to rely on technical judgment to guide our replacement policies.

26.7.1 Risk-Cost

Risk-cost is the probability that an adverse event occurs multiplied by the cost if it does. Although risk-cost can be a useful guide to our thinking, the product of a very low probability multiplied by a very high cost does not always result in a meaningful value when related to conventional financial analysis.

For example, the probability of an old transformer failing in the coming year was estimated at 1 % and the cost of this event at \$5,000,000. The product of these numbers gives a risk-cost of \$50,000. \$50,000 is too small an amount to warrant replacement, but in practice the senior management made the decision to replace based on the potential impact of a major failure at the overall business and political level.

26.8 Linear Assets^{1,2}

A “linear asset” is an asset which is physically long, consists of a series of individually inexpensive sections or components, but delivers a valuable service, with high costs if the service is interrupted. Examples are water mains, oil and gas pipelines, roads, railway track, and electricity power lines. The critical factor is service availability. Replacement problems associated with linear assets have particular characteristics which are discussed here.

¹ The Replacement Decision For Linear Assets, P. Buckland and N. Hastings, (International Conference of Maintenance Societies—ICOMS 2001—Melbourne, Australia—May 2001).

² Buckland P—“Risk Based Economic Life Cycle Management of Infrastructure Assets and its Regulatory Implications”—Proc. International Conference of Maintenance Societies ICOMS 2000—Wollongong—May 2000.

26.8.1 Cost Structure

Linear assets typically have the following features.

- There is a significant initial capital outlay.
- There are little or no operating costs.
- Routine maintenance costs are low.
- For a long time there are few failures.
- There are minimal administrative costs.
- Failures cause high costs to users.
- Failures are repaired promptly, usually as an urgent job.
- Short lengths of the asset can be repaired quickly and relatively cheaply.
- Eventually the asset condition deteriorates significantly.
- Eventually there are significant risk costs.
- Repeated failures are unacceptable and eventually a major refurbishment is needed.
- The extent of and timing of refurbishment are hard to decide.
- Disposal cost is low.

The key characteristic is the eventual occurrence of failures which have high costs to users. Individual failures can be fixed and the cost of repair is relatively small, but repeated failures are unacceptable. Guidelines for making the decision to refurbish some or all of the asset can be:

- the failure rate, such as failures per kilometer per year,
- an availability figure which takes account of failure rate and time to repair (outage time),
- a failure severity measure,
- a cost-based measure which assigns costs to the outages. In this case replacement can occur when marginal cost exceeds the estimated EAC of the replacement,
- a risk-cost based measure for items which can be catastrophic if they fail, such as trunk water mains.

26.8.2 High Consequence Assets

High consequence assets, such as trunk water mains, are assets that we do not want to fail at all. Where risk comprises rare but very high consequence events, such an event may not have occurred in the past and it will not be reflected in historical records. For trunk mains, we would expect to be making the replacement decision without having a failure history.

In such cases, we are dependent on predictive assessment which will indicate at what stage in the degradation of the asset we will make a replacement. This is primarily a technical assessment and may be based on a combination of observed condition and technical information based on such factors as erosion or corrosion rates, fatigue life, or wear rates. It is important that adequate steps are taken to monitor the risks associated with high consequence assets and to act in time to

avoid failure. High consequence assets feature an economic life shorter than their physical life.

The risk analysis involves the less tangible aspects of failure such as social impact and image damage.

26.8.3 Low Consequence, Long Life Asset Replacement

Consider an asset type with low failure consequence, which has a high acquisition cost, followed by a long period with little or no expense. This is typical of many linear assets. Some failures are acceptable and the rate may be low when the asset is new, so initially we may operate on a run-to-failure basis. Later, the failure rate rises as the assets age, and will gradually become unacceptable. It is important to monitor the failure rate so that we become aware of when to consider the introduction of a replacement or refurbishment policy which goes beyond minimal repairs.

Thus in this case we switch from an initial repair-only-on—failure policy to a refurbishment policy once the failure rate becomes significant. The increase in failure rate is not necessarily uniform across the population. For example, in an electricity transmission network, lines close to the coast will be subject to faster rates of corrosion than lines inland. This is due to salt laden air. Also, lines in exposed open terrain will be subject to wind-induced vibration to a greater extent than lines in sheltered locations, leading to possible fatigue failures.

26.9 What Length of Asset Should Be Replaced?

Another issue that arises with linear assets is deciding how much of the asset, should be replaced in any one replacement episode.

For the purpose of maintenance or replacement of linear assets it is convenient to consider them as being made up of discrete sections. This may be driven by physical attributes, e.g., the span between transmission line towers or sewer access shafts, or by the limitations of data capture systems in providing detail of asset performance. It may also be influenced by failure patterns or environmental conditions.

What do we replace and what do we leave? Do we replace only individual sections with a failure history? What do we do about sections with no failure history but which are located adjacent to those being replaced?

26.9.1 Cost Structure of Replacement

With most linear assets there are economies of scale such that it is cheaper per meter to replace longer lengths. This affects the decision as to how much of a degraded asset should be replaced. Figure 26.6 shows the variation of fixed costs

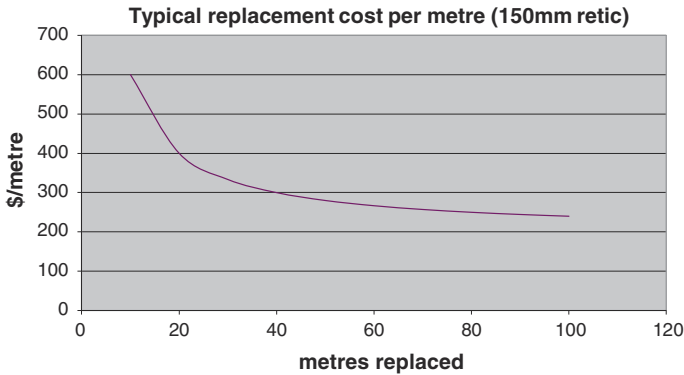

Fig. 26.6 Economy of scale in pipe replacement

with price per meter and total length laid in a single episode for 150 mm water mains. It is evident from Fig. 26.6 that the EAC of a section of a linear asset will be dependent on the magnitude of the project by which it is acquired.

The decision as to how much of an asset to replace in any one episode will depend on a number of factors. These include:

- the physical practicalities of replacement,
- the relationship between the site establishment fixed costs,
- the length-related variable costs of replacement,
- the condition of the asset under consideration, and
- site-specific considerations.

Fixed costs include:

- Site establishment;
- Notification to customers of a planned replacement;
- Social cost of disruptive event (outrage, loss of amenity);
- Administration (contract preparation, tendering, payment etc.).

Variable costs include:

- Labor
- Plant
- Material
- Administration (contract admin and supervision)
- Social cost of extended disruption (traffic disruption, commercial disruption, residential access problems, noise, unsightliness, etc.). This is a cost that displays an increasing rate with time.

The cost structure of the replacement process is such that it imposes disincentives for too small a replacement and for too big a replacement. We may therefore, surmise that with all benefits and costs considered there will be a site-specific “preferred” replacement episode.

Fig. 26.7 Condition of linear asset

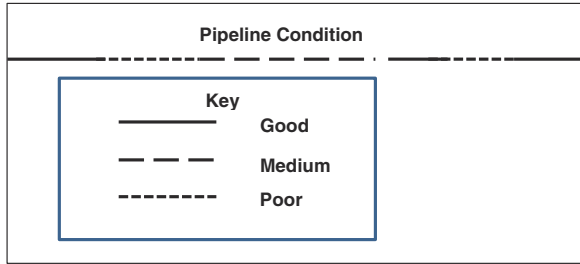

26.9.2 Contiguous Replacement

Consider the linear asset shown as “Pipeline Condition” in Fig. 26.7. This has sections featuring good, medium, and poor condition distributed along its length.

A number of options can be considered, such as:

- to replace only the poor sections one at a time in separate jobs,
- replace only the poor sections in one job,
- to replace the poor and adjacent medium sections in separate jobs,
- to replace a contiguous length including both poor sections and the sections in between in a single job.

Decisions must be made between these options and there is no simple formula. The techniques already outlined can be used to evaluate particular cases.

26.9.3 Linear Assets Conclusion

Linear assets have specific characteristics which complicate the replacement policy. Degradation can creep in gradually and may have serious consequences. The factors outlined in this section form a basis for informed decisions on the replacement of linear assets. The actual decision in any particular case will depend on the balance of condition, cost, and disruption factors, and will need to be made on a case-by-case basis.

26.10 Component Replacement³

Components may be replaced on the following bases:

- On condition

³ N.A.J. Hastings, Component Replacement Analysis with Incomplete Failure Data, in *Case Studies in Reliability and Maintenance*, W. R. Blischke and D.N.P. Murthy eds., Wiley, New York, 2003.

- On age or service life
- On failure

It is also possible to use these policies in combination.

26.10.1 Condition-Based Replacement

A condition-based replacement is a replacement which is carried out when a component is still working satisfactorily, but inspection or monitoring shows that it has degraded and can be expected to fail in the near future. Condition-based replacement is a sound policy if it is technically and economically feasible to apply an effective condition monitoring policy to the component.

Otherwise, the choice is between an age-based policy or a replace-only-on-failure policy.

26.10.2 Failure Replacement and Run-to-Failure

A failure replacement is a replacement that occurs following the failure of a component in service. Whatever the policy, replacement will be required if the component actually fails. If no other policy is adopted, the policy will be to replace only on failure, also known as run-to-failure. This may not be acceptable because of the cost of failure and possible safety or environmental consequences.

An example, where a run-to-failure policy is commonly applied, is with domestic lighting. The consequences of an individual light failing are not severe and there is no suitable condition monitoring system. Redundant systems can generally be suited to a run-to-failure policy, with the switch to a standby or parallel system allowing time for replacement to occur.

26.10.3 Age-Based or Service-Based Replacement

An age-based or service-based replacement is a replacement which is carried out when a component is still working satisfactorily, but we consider it advisable to replace it on a basis of age or in terms of service life, such as flying-hours.

Data on component ages must be kept for this policy to be applied. Age-based replacement should not be applied where the failure rate is decreasing or constant, as the new item will be no more reliable than the old. We therefore need to carry out analysis or make a technical judgement as to the age at which the failure rate

will increase. However, it may be necessary at times to make age-based replacement in anticipation of a rising failure rate before another replacement opportunity arises. Age-based rules commonly apply to safety-critical components such as pressure safety valves and aero-engines. Methods for determining when the failure rate starts to increase are discussed in Chap. 21, Sect. 21.7.4.1 under the headings of statistical analysis and age exploration.

26.11 Exercises

26.11.1 Vehicle Replacement Exercise

A vehicle currently has a resale value of \$25,000 and is estimated to have a resale value of \$18,000 in a year's time. The maintenance cost of the vehicle for the coming year is \$3,500, assumed to be incurred at the end of year.

The life cycle EAC of a new vehicle is estimated at \$10,000 per year. Should the old vehicle be replaced now?

- a. assuming zero interest; and
- b. assuming interest at 10 % p.a.

26.11.2 Transformer Replacement Exercise

An electricity transmission company has a transformer which is currently 40-years old. The operating and maintenance costs for this item for the next 4 years have been assessed as follows. Assume that these costs are incurred at the END of the respective years. Assume that the old transformer will not be kept for more than 4 years.

Year	1	2	3	4
Cost	14,250	14,200	24,000	45,450

A new transformer of modern design can be purchased for \$300,000. The new transformer can be assumed to have a 40-year life. The cost of capital is 8 % and the 40-year annuity factor at 8 % per annum is 11.9246. The annual operating and maintenance cost for the new transformer is estimated at an EAC of \$2,700 per annum.

- (a) On the basis of this data, at what age should the old transformer be replaced? Show your working.
- (b) If the old transformer needed a repair, costing \$30,000, should this repair be carried out or should the old transformer be replaced now? Assume that the old transformer has no net disposal value. Assume that this repair will not affect the future costs shown in the table. Show your working.

Transformer replacement solution template:

1. Calculate new transformer EAC

Capital cost	
Life in years	
Annuity factor	
Capital cost EAC	
Maintenance cost EAC	
Total EAC	

2. Calculate new transformer cumulative NPV

1	Year	1	2	3	4
2	New trans EAC				
3	Discount factor	0.9259	0.8573	0.7938	0.7350
4	New trans NPV				
5	New trans cumul NPV				

3. Calculate old transformer cumulative maintenance cost, rows 6–8
4. Calculate savings from keeping old transformer, row 9

6	Old trans maint	14,250	14,200	24,000	45,450
7	Old trans maint NPV				
8	Old trans cumul maint NPV				
9	Savings row 5–row 8				

Answer

- (a) Replacement Age =
- (b) Repair Yes/No.

26.11.3 Spend-Limit Exercise

A company has a machine that requires a reconditioned engine at a cost of \$25,000, but is otherwise satisfactory. We estimate that the machine will last for three more years if it gets the new engine, and that its expected maintenance cost over this period will be \$3,000 per year. The Life Cycle Equivalent Annual Cost (EAC) of a new machine is \$10,000 per year.

Should we replace the engine or scrap the old machine? Assume zero resale value if the machine is scrapped. Ignore discounting over the 3-year period.

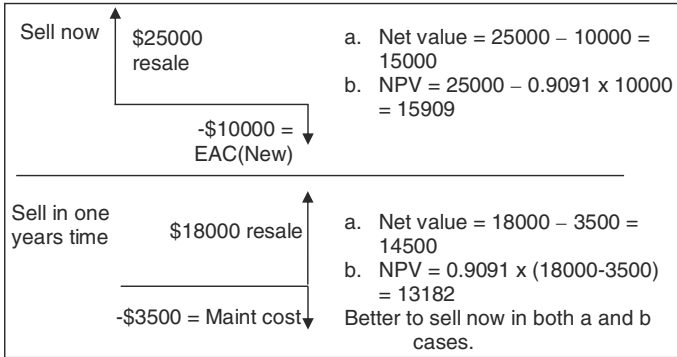

Fig. 26.8 Vehicle replacement options

26.12 Solutions to Exercises

26.12.1 Vehicle Replacement Exercise Solution

It is better to sell now in both the (a) and (b) cases (Fig. 26.8).

26.12.2 Transformer Replacement Exercise

Calculate new transformer EAC

Capital cost	300,000
Life in years	40
Annuity factor	11.9246
Capital cost EAC	25,158
Maintenance cost EAC	2,700
Total EAC	27,858

Calculate new transformer cumulative NPV

1	Year	1	2	3	4
2	New trans EAC (EOY)	27,858	27,858	27,858	27,858
3	Discount factor	0.9259	0.8573	0.7938	0.7350
4	New trans NPV	25,794	23,882	22,114	20,476
5	New trans cumul NPV	25,754	49,678	71,793	92,269

Calculate old transformer cumulative maintenance cost NPV. Calculate savings from keeping old transformer (row 9)

6	Old trans maint EOY	14,250	14,200	24,000	45,450
7	Old trans maint NPV	13,194	12,174	19,052	33,407
8	Old trans cumul maint NPV	13,194	25,368	44,420	77,827
9	Savings row 5–row 8	12,600	24,310	27,373	14,442

Answer

- (a) Replace at age 43 (savings are maximum).
 (b) Do not repair as savings < 30,000.

26.12.3 Spend-Limit Exercise

The spend-limit is given by:

$$\begin{aligned} \text{Spend} - \text{limit} &= \text{EAC}(\text{new}) * 3 - \text{Annual maintenance cost of old} * 3 \\ &= \$10,000 * 3 - \$3,000 * 3 = \$7,000 * 3 = \$21,000. \end{aligned}$$

The maximum that we should be willing to spend on repair is \$21,000.

To repair the old machine will cost \$25,000.

Hence, it is cheaper to replace the old machine.

Alternative method with the same result:

Cost of old = 3 * 3,000 + 25,000 = \$34,000

Cost of new = 3 * 10,000 = \$30,000 = cheaper.

Chapter 27

Further Financial Topics

Abstract The aim of this chapter is to discuss a number of financial topics beyond the basic financial analysis methods that were introduced in Chap. 5. These topics are important in the management of assets. An understanding of these topics will be of value in contributing to asset management decisions. *Outcomes* You will learn about aspects of business financing, about comparing and selecting projects and issues involved in leasing. The chapter concludes with a consideration of the concepts of fixed and variable costs and break-even analysis.

27.1 Debt and Equity Financing

The capital used by a company generally has one of two types of source: debt capital or equity capital.

Debt capital is money borrowed from a bank or other source and the cost is the loan interest rate. The repayment schedule is a firm commitment and the business is insolvent if it cannot be met.

Equity capital is money provided by investors, either by the purchase of shares or as retained earnings. The cost reflects the expectations of shareholders, who benefit from dividends and also from any increase in the value of the company. Usually the expected return on equity is higher than on debt, but if business is bad, dividends can be reduced or omitted without the company becoming insolvent.

Gearing is the ratio of debt to debt plus equity. Since the interest on debt capital must be paid, a highly geared company is at relatively high risk.

Weighted Average Cost of Capital (WACC) is the cost of capital to the company, taking an average of the proportion of debt and the interest rate on debt with the proportion of equity and the expected return on equity.

27.2 Comparison and Selection of Projects

Asset investment criteria were introduced in Chap. 5, Sect. 5.4. Some additional considerations beyond the basic methods are outlined here.

27.2.1 Project Comparability

In making project comparisons it is important to ensure that the options are treated comparably in relation to:

- Starting conditions;
- Ending conditions;
- Project duration and duration of service;
- Performance and output planned and achievable.

The suggested basic method is to rank projects by their Profitability Index at the Minimum Acceptable Rate of Return. Where different production capacities are involved we need to consider cost per unit of production.

27.2.2 Planning Horizon

In analyzing an investment project we need to choose a planning horizon or planning cycle. Care must be exercised to ensure that the choice of horizon does not bias the result. Calculating an NPV for a finite horizon is the easiest method to comprehend. Be careful to set reasonable terminal values, such as written down values or resale values, depending on the age of items at the horizon. Discounting makes terminal values less critical in long projects. Annualized costs are useful as a basis for comparing costs incurred with differing life cycle durations.

27.2.3 With and Without Analysis

The financial measures described in Chap. 5 focused on specific discrete projects. In practice, projects may not be mutually exclusive, so that the choice of one project may mean that one of the others is not needed, or has to be modified. More generally, with many complex factors interacting, it may be advisable to consider the desirability of a project on a “with or without” basis. That is, we consider scenarios of what will happen if we *do* the project compared with what will happen if we *do not* do it. This approach can often clarify the situation and lead to a decision to proceed, not proceed, or to modify the project.

27.3 Inflation



Inflation means that identical goods cost more money now than they did a year ago. Equivalently, it means that prices were lower for the same items in the past. Deflation, on the other hand, corresponds to a decrease in the price of goods with time. The inflation rate is distinct from the interest rate. However, the two are not entirely unrelated, as the interest rate will normally exceed the inflation rate, otherwise there will be no attraction in saving or investing.

Historical average inflation rates are published by statistical authorities, for example, the Consumer Price Index (CPI). Where we wish to compare costs which are incurred a few years apart, we can bring them to a common reference date. This is usually the current year, and we then refer to the money unit as “*today’s dollars*.”

The expression “*real terms*” is used to indicate that a money quantity has been adjusted to allow for inflation. The unadjusted figures we refer to as “*nominal*” dollars. The inflation rate usually varies from year to year.

27.3.1 Adjusting Historical Costs

Consider a maintenance cost of \$6,500 incurred 2 years ago. We may wish to compare that in real terms with the cost of a similar task performed in the current year. If the inflation rate was 7 % last year and 9 % the year before, we must first inflate the cost by 9 % and then inflate the result by further 7 % to put the cost into today’s dollars. In this case the result would be:

$$\text{Cost in Today's Dollars} = 6,500 \times (1 + 0.09) \times (1 + 0.07) = 7,581 \quad (27.1)$$

Try this question.

\$20,000,000 was spent last year on maintaining a water supply system, \$20,500,000 is budgeted for this year. Inflation between the years was 4 %.

Which of the following is true?

- a. Expenditure has increased,
- b. Expenditure has declined in real terms.

(Answer: Both)

27.3.2 Real Rate of Interest

The “real” rate of interest is the annual increase in the value of invested money in terms of its purchasing power, allowing for inflation. In long-term financial analyses, such as life cycle costing, it is common to use the real rate of interest rather than the bank interest rate on loans.

The real rate of interest is approximately equal to the bank interest rate minus the inflation rate. Thus if the bank interest rate is 9 % and the inflation rate is 4 % then the real rate of interest is approximately 5 %. The precise relationship is given in Eq. 27.2.

r = bank interest rate as a decimal

f = inflation rate as a decimal

t = real interest rate as a decimal

$$t = (r - f) / (1 + f) \quad (27.2)$$

It is not unusual to use the approximation $t = r - f$, rather than the exact formula.

27.3.3 Adjusting Future Costs

Inflation and interest rates vary widely over time, and are hard to predict. In assessing real costs or values over long periods, great accuracy cannot be expected. Also, some items are not subject to inflation. For example, maintenance costs will inflate, but annual repayments and depreciation based on the original acquisition cost of an item will not inflate. As a guideline, in making financial planning calculations, adjust all inflatable amounts into today’s dollars and use the real rate of interest.

27.4 Asset Valuation

Asset valuation is subject to accounting rules and the relevant rules should be identified and applied. An asset manager should consult accounting professionals in regard to the preferred method for the circumstances.

The traditional financial value of an asset is the acquisition cost minus the accumulated depreciation. This is the conventional book value. This value is objective; that is, anyone applying the same rule will get the same result.

Another concept is “fair value” which involves estimating the Depreciated Current Replacement Cost.¹

27.4.1 Current Replacement Cost

The asset manager is generally concerned with maintaining an ongoing provision of assets. This involves making financial provision for the declining value of assets over their lifetime, but also involves considering changes in service requirements, in technology, and in the condition of particular assets. Relevant concepts are:

- Current Replacement Cost (CRC) is the cost which would be incurred if the item had to be replaced with the modern equivalent. This will take account of price changes, technical and regulatory developments, and changes to service expectations which have occurred since the original item was acquired.
- Expected Useful Life (EUL) is an estimate of the life of an asset, taking account of environmental or operational factors which may give a life which is different from the effective life set by accounting rules. The default value, however, is the effective life.
- Asset condition. See also Sect. 9.8 of this book. Normal depreciation reflects some loss of condition in a general sense. If the condition of an asset is significantly different from the norm for its age, then we need to take account of this.
- Expected Remaining Life (ERL). For an asset in average condition the Expected Remaining Life is the Expected Useful Life minus the Age. If the condition is significantly different from the norm for its age, then an ERL specific to the particular asset may be assigned.

27.4.1.1 Depreciated Current Replacement Cost

To obtain an asset valuation based on current costs we assess the current replacement cost of the item and then depreciate that to allow for the age of the current item in relation to its expected useful life. We refer to the result as the Depreciated Current Replacement Cost (DRC). The formula for the DRC of an item in average condition is:

$$\text{DRC} = \text{CRC} * (\text{EUL} - \text{Age}) / \text{EUL}. \quad (27.3)$$

¹ Fair value is defined in AASB116. Fair value measurement is considered in AASB13.

For an item whose condition is such that its Expected Remaining Life (ERL) differs from the average, the formula is:

$$\text{DRC} = (\text{CRC} * \text{ERL}) / \text{EUL}. \quad (27.4)$$

For example, consider an item with an effective useful life of 40 years and which is currently 20 years old and is in average condition. Its current replacement cost is assessed at \$50,000. Assuming straight line depreciation the assessed DRC by this method is $\$50,000 \times 20/40 = \$25,000$.

If the item is in poorer condition than average, we might assess its remaining life at 10 years, even though it is only 20 years old. In this case the DRC is $\$50,000 \times 10/40 = \$12,500$.

27.4.2 Deprival Value

This is the cost that would be incurred if the organization no longer had the item. The idea is that a like-with-like replacement would not necessarily occur due to wider changes in the business environment. On the one hand, an organization might be happy not to possess some of the assets which appear in its books, in which case the deprival value can be zero. At the other end of the scale, the deprival value takes account of how much worse off the owner would be if they did not have the asset, but wanted to continue on with business, taking all current and future considerations into account. For example, a person owns an old car with zero book value and zero resale value. However, the car serves the purposes of the owner, who would be faced with buying another if they were deprived of the old one. The deprival value can be highly volatile as circumstances change. This concept appears in some regulatory schemes.

27.4.3 Asset Value Index

An asset value index is a number which gives an indication of the value of the assets relative to the value of similar new assets. If we are using Depreciated Current Replacement Cost as the valuation method, we define an asset value index as the ratio of the Depreciated Current Replacement Cost (DRC) to the Current Replacement Cost:

$$\text{Asset Value Index} = \text{DRC} / \text{CRC} \quad (27.5)$$

Consider an asset with an effective life of 10 years, with straight line depreciation; when it is 5 years old its Asset Value Index, in percentage terms, will be 50 %.

The index can be applied to a group of assets by dividing the total Depreciated Current Replacement Cost of the group by the total Current Replacement Cost of the group. For the group, the Asset Value Index is given by:

$$\text{Asset Value Index} = \frac{\text{Group Total Depreciated Current Replacement Cost}}{\text{Group Total Current Replacement Cost}}$$

The index can be applied to the whole asset portfolio of an organization, so that a plant with all new assets would have an Asset Value Index of 100 %, while a plant with all very old assets which had been fully depreciated would have an Asset Value Index of 0 %. Taking it across the range of a company's assets, it indicates how the assets stack up in terms of their age relative to their effective lives. If the index is well below 50 %, then major capital expenditure is likely to be needed in the near future.

The Asset Value Index also serves as a pointer to the actions of management in relation to fixed assets. If the index is falling, we should expect evidence that the management is initiating plans for renewal at the appropriate times, and for the financing of the new items through a sinking fund or retained profits, for example. The Asset Value Index should be reported in the annual accounts, giving a direct insight into the asset health of the company. A low value does not indicate a bad situation provided that financial provision has been made for the replacements which will soon be needed.

27.5 Sinking Fund

A sinking fund is money that we accumulate so that we have it available when replacements or refurbishments of assets are needed. For example, the owners of an apartment block which has a swimming pool will want to refurbish the pool to current standards from time to time. To cover the cost of replacement or refurbishment we need to build up the sinking fund over the period leading to the time when the expenditure is needed. The guideline for how much should be in the sinking fund at any time is:

$$\begin{aligned} \text{Sinking Fund Amount} &= \text{Current Replacement Cost} \\ &\quad - \text{Depreciated Replacement Cost} \end{aligned}$$

If the sinking fund is held in an interest bearing account, we can take advantage of the interest generated. The discounted cash flow analysis of this situation is documented in finance textbooks.

27.6 Leasing

Leasing is hiring equipment rather than purchasing it. The lessee has the use of the equipment, but ownership remains with the lessor.

Features of leasing are:

- a. Often the cheapest way to meet a short-term requirement;
- b. Avoids a capital requirement.
- c. Avoids long-term commitment to specific assets, providing flexibility
- d. Reduces fixed costs. The fixed costs associated with the equipment become the responsibility of the lessor;
- e. Will generally be more expensive in meeting a long-term commitment, as the lessor will need to make a profit;
- f. The whole cost is tax deductible in current year.
- g. Risk in equipment reliability and performance is transferred to lessor.

In making a financial comparison, compare the lease cost rate with the EAC of ownership, or compare the total leasing cost with the NPV of ownership over the corresponding period.

27.7 Loan Repayment

Because interest payments are tax deductible, in some applications we may wish to calculate separately the amount of interest paid and the amount of capital repaid year by year on a loan. Suppose that we borrow an amount, known as the Principal, at a given interest rate, repayable by equal annual installments over a number of years. The Excel functions PPMT and IPMT give the capital and interest repayments year by year.

Figure 27.1 shows an example of the use of the Excel functions PPMT and IPMT to calculate loan repayment principal and interest. The loan amount is

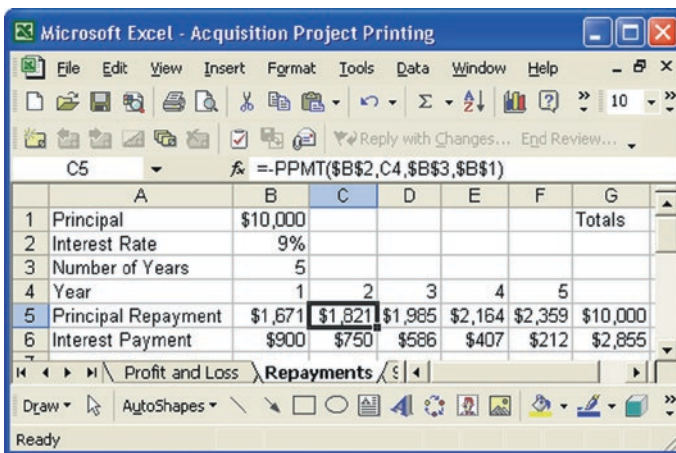

Fig. 27.1 Loan repayment calculations

\$10,000 shown in cell B1. The interest rate is 9 % shown in cell B2. The repayment period is 5 years shown in cell B3. The repayments of principal are shown in row 5 and of interest in row 6. As an example, the PPMT function for cell C5 appears in the function field. PPMT and IPMT reverse the sign from that of the Principal, so a minus sign has been used in the function field to give positive answers.

27.8 Fixed Costs, Variable Costs, and Break-Even Analysis

Fixed costs are costs which do not vary with the volume of business. Variable costs do vary with the volume of business. Examples of fixed costs are:

- The interest on loans for the purchase of plant or buildings;
- The cost of inspection of a boiler which is required to be carried out annually, regardless of the extent of utilization of the boiler.

Examples of variable costs are:

- Costs of materials used in manufacturing;
- Fuel costs which depend on volume of production or vehicle utilization.

The profit made by a company in a given year is based on the sales revenue minus the sum of variable and fixed costs. Products have an *operating profit margin*, given by their selling price minus the variable cost of production. As a year proceeds and sales are made, the cumulative operating profit increases, initially to cover the fixed costs and then to yield an overall profit. At a given operating margin, a business is more assured of avoiding a loss making situation if its fixed costs are low. This also applies even if the reduction in fixed costs causes a moderate loss in operating margin. Figure 27.2 illustrates the situation.

Fig. 27.2 Fixed and variable costs

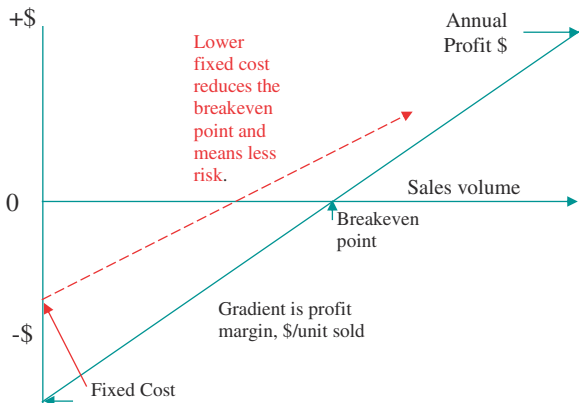

For this reason, there is always a desire to reduce fixed costs. This can lead to pressure to reduce maintenance costs, which often include a large element of fixed costs. But there is then the danger that if the maintenance budget is too low, greater losses will occur, due to lack of machine availability, and that catastrophic failures may occur. Awareness of the fixed cost issue helps managers to assess the role of fixed and variable costs in a budget setting.

Leasing, renting, and outsourcing are activities that convert fixed costs to variable costs. They give a business greater flexibility in the event of a downturn in sales. However, if business is good, they tend to reduce profits by being more expensive than direct ownership.

27.9 Regulation

Regulation by government authorities is introduced to avoid excess profits in monopolies. Typically, this occurs when utilities are privatized in the electricity, water, gas, road, and rail industries. It is important to ensure that the regulatory regime does not discourage continuing investment.

27.9.1 Methods

The aim of the regulator is to limit the profit of the company to an acceptable level. This can be done by limiting the prices which to company can charge, or by limiting the revenue that they can generate. The following methods may be used:

- Pricing is restricted to cost plus
- Price cap. Prices are capped by the regulator
- Self-regulation—Set own rules but need to justify to regulator
- Revenue cap—based on asset replacement value or on depreciated asset replacement value

In an example of the revenue cap case the Maximum Allowable Revenue in year (MAR) is calculated as:

$$\text{MAR} = \text{Return on capital} + \text{Return of capital} + \text{opex}$$

$$\text{MAR} = (\text{WACC} * \text{WDV}) + \text{D} + \text{opex}$$

where

WACC Weighted Average Cost of Capital
 WDV Written Down Value of the assets
 D Depreciation in a year
 opex Operating expense

The regulator may specify that the operating expense should grow at less than the inflation rate, a rule known as CPI-X. There may be bonuses or deductions related to performance parameters such as on-time running of railways, power outages, water pressure loss.

A theoretical model used in regulation is the *Capital Asset Pricing Model*. A concept to come out of this is the risk parameter referred to as “beta”. A beta value of 1 represents the risk level of an average stock market investment. A beta value of less than one represents a safer investment, traditionally such as a utility. A beta value greater than one represents an investment which is considered riskier than the market average.

27.9.2 Need for Adequate Returns

If regulation provides too little return to a utility, investment in plant may decline, resulting in power shortages. Short-term investments (e.g., gas turbine power plants) may be made instead of long term. An example is a gas pipeline built on a government commitment to a gas retail price of \$1 per unit, but this was later reduced to 81 cents by the regulator, sending the pipeline owners into liquidation.

If regulated returns are based on book asset values, thus penalizing older assets, there will be a switch from a maintenance and refurbishment focus to the early acquisition of new plant.

27.9.3 Stranded Assets

A stranded asset is an asset which has lost value due to a change in circumstances. Example: Bell Bay power station in Tasmania runs on natural gas and produces power at a cost of about \$50 per Megawatt-hour. A cable, known as Basslink, was built later which supplies electricity to Tasmania from coal fired power stations in Victoria, where costs are about \$14 per Megawatt-hour. Bell Bay became a stranded asset (based on a Tasmanian newspaper report dated 1 June 2005).

27.10 Concluding Discussion

The primary role of the asset manager in regard to asset-based financial decisions is to ensure that decisions are in accord with the physical realities of the asset situation. This involves providing accurate data and sound technical assumptions which underpin the management decisions. An important part of the process is good communication between the asset management and finance groups. To achieve this communication, it is important that asset managers understand the

terminology and concepts employed by finance. The precise details of financial analysis will remain the responsibility of the finance department.

The examples in this chapter are intended to provide an introduction to the financial process, but local terminology and procedures may differ in detail from those given here. You should identify the precise forms of financial statements used within your organization.

27.11 Exercises

27.11.1 *Self-Assessment Quiz*

Explain the following terms:

1. Debt capital
2. Equity capital
3. Gearing
4. Weighted Average Cost of Capital (WACC)
5. Real rate of interest

Questions:

6. What is the normal method for valuing an existing fixed asset?
7. What is meant by the Current Replacement Cost of an item?
8. What is a sinking fund?
9. Identify four or more features of leasing rather than purchasing equipment.
10. What is the difference between fixed and variable costs?

27.11.2 *An Asset Investment Case Study*

The following example illustrates the use of the Profit and Loss account and an analysis of cash flows to evaluate the financial merits of a proposed development.

27.11.2.1 Data

The Token Power Company has the opportunity to develop a gas fired power station to provide electrical power for an industrial site. The cost data are shown in Fig. 27.3. For purposes of this example, the life of the plant has been set at a nominal 7 years. The plant is to be depreciated by the straight line method over 7 years.

In Fig. 27.3 we see that the initial cost of the plant is \$50 million. This is to be covered by a \$30 million loan and \$20 million in equity. The loan is to be repaid over 7 years. The revenue from the sale of electrical power is estimated at \$135

Fig. 27.3 Power system data

	A	B
1	Initial Cost	50,000,000
2	Loan	30,000,000
3	Equity	20,000,000
4	Interest Rate on Loan	8%
5	Discount Rate for Planning	10%
6	MARR	15%
7	Company Tax Rate	30%
8	Project Life Years	7
9	Annual Revenue	135,000,000
10	Annual Costs	100,000,000

million per year and the cost of providing this power (mainly the purchase of gas) is \$100 million per year. Figure 27.3 also shows the interest rate on the loan at 8 %, the company tax rate at 30 % and two interest rates used in planning analyses, namely a Planning Rate of 10 % and the Minimum Acceptable Rate of Return (MARR) of 15 %.

Your aim is to determine whether this Power Plant will be a good investment. Will it make a profit? What will be the payback period? What will be the Net Present Value over the 7 year period? Should we go ahead with the building of the power plant on the basis of the given data?

27.12 Exercise Solutions

27.12.1 Self-Assessment Quiz Solution

1. *Debt capital*

Debt capital is money borrowed from a bank or other source and the cost is the loan interest rate. The repayment schedule is a firm commitment and the business is insolvent if it cannot be met.

2. *Equity capital*

Equity capital is money provided by investors, either by the purchase of shares or as retained earnings.

3. *Gearing*

Gearing is the ratio of debt to debt plus equity.

4. *Weighted Average Cost of Capital*

Weighted Average Cost of Capital (WACC) is the cost of capital to the company, taking an average of the proportion of debt and the interest rate on debt with the proportion of equity and the expected return on equity.

5. *Real rate of interest*

The real rate of interest is the annual increase in the value of invested money in terms of its purchasing power, allowing for inflation.

6. *What is the normal method for valuing an existing fixed asset?*

The normal method of valuation of an asset is the acquisition cost minus the accumulated depreciation.

7. *What is meant by the Current Replacement Cost of an item?*

Current Replacement Cost (CRC) is the cost which would be incurred if an existing item has to be replaced with the modern equivalent.

8. *What is a Sinking Fund?*

A sinking fund is money that we accumulate so that we have it available when replacements or refurbishments of assets are needed.

9. Identify four or more features of leasing rather than purchasing equipment.

Features of leasing are:

- a. Often the cheapest way to meet a short-term requirement;
- b. Avoids a capital requirement. This is an advantage if there is a restriction on available capital.
- c. Avoids long-term commitment to specific assets, providing flexibility
- d. Reduces fixed costs. The fixed costs associated with the equipment become the responsibility of the lessee;
- e. Will generally be more expensive in meeting a long-term commitment;
- f. The whole cost is tax deductible in the current year.
- g. Risk in equipment reliability and performance is transferred to lessor.

10. What is the difference between fixed and variable costs?

Fixed costs are costs which do not vary with the volume of business. Variable costs do vary with the volume of business.

27.12.2 Asset Investment Case Study Solution

27.12.2.1 Profit and Loss Accounts

In order to determine the profitability of the proposal we develop projected Profit and Loss accounts for the 7-year period. Figure 27.4 shows this.

Row 13 shows the projected revenue of \$135,000,000 per year.

Row 14 shows the operating costs incurred in generating the revenue.

Row 15 shows the operating profit.

The initial cost of the plant, \$50 million, is depreciated linearly over seven years as shown in row 16. The \$30 million loan is repaid over the 7 years. The Excel functions PMT, IPMT and PPMT are used in rows 17, 18, and 19 to calculate the annual repayments and the split of these between interest expense and capital repayments. The interest expense is tax deductible.

The taxable income is then calculated (row 21) and also the tax paid (or to be paid) at row 22. This gives the profit (after tax) shown at row 23. In round figures and without discounting, the profit is approximately \$25 million per year. We need to relate this to accepted criteria for return on investment.

	A	B	C	D	E	F	G	H	I
12 Year(EOY)		0	1	2	3	4	5	6	7
13 Revenue			135,000,000	135,000,000	135,000,000	135,000,000	135,000,000	135,000,000	135,000,000
14 Costs			100,000,000	100,000,000	100,000,000	100,000,000	100,000,000	100,000,000	100,000,000
15 Revenue-Cost			35,000,000	35,000,000	35,000,000	35,000,000	35,000,000	35,000,000	35,000,000
16 Depreciation			7,142,857	7,142,857	7,142,857	7,142,857	7,142,857	7,142,857	7,142,857
17 Repayments			5,762,172	5,762,172	5,762,172	5,762,172	5,762,172	5,762,172	5,762,172
18 Interest			2,400,000	2,131,026	1,840,535	1,526,804	1,187,974	822,038	426,828
19 Principal Paid			3,362,172	3,631,146	3,921,637	4,235,368	4,574,198	4,940,134	5,335,344
20 Loan Remaining			26,637,828	23,006,682	19,085,045	14,849,676	10,275,478	5,335,344	0
21 Taxable Income			25,457,143	25,726,117	26,016,608	26,330,339	26,669,169	27,035,105	27,430,315
22 Tax Paid			7,637,143	7,717,835	7,804,982	7,899,102	8,000,751	8,110,531	8,229,095
23 Profit (after tax)			24,962,857	25,151,139	25,354,483	25,574,095	25,811,275	26,067,430	26,344,078

Fig. 27.4 Profit and loss

27.12.2.2 Investment Analysis for the Power System Project

To evaluate the Power System project we apply the following methods:

- Payback Period
- Net Present Value
- Internal rate of Return

Payback Period

The calculation of the payback period is shown in Fig. 27.5 at rows 25–29. The amount invested in the project is \$50 million, but this reduces as the loan is repaid. The equity plus loan remaining in the project is shown at row 28. The cumulative present value of the profit is shown in row 27. The payback period is reached when the cumulative present value of the profit exceeds the equity plus loan remaining in the project. At that point our costs are recovered. This occurs by the end of year 2, so the payback period is 2 years. This is a positive indicator for this investment, as the short payback period indicates that there is relatively little risk of our forecasts going wrong before the investment is recovered.

	A	B	C	D	E	F	G	H	I
24									
25 Year		0	1	2	3	4	5	6	7
26 Payback Period Analysis at Planning Rate (10%)									
27 NPV of Cumulative Profit			22,693,506	43,479,572	62,528,770	79,996,221	96,022,992	110,737,377	124,256,054
28 Equity+Loan Remaining		50,000,000	46,637,828	43,006,682	39,085,045	34,849,676	30,275,478	25,335,344	20,000,000
29 The NPV of cumulative profit exceeds the Equity +Loan Remaining by end of year 2. Payback period is 2 years.									
30									
31 NPV of Project at Planning Rate (10%)									
32 Cash flow		-20,000,000	21,600,685	21,519,993	21,432,845	21,338,726	21,237,077	21,127,297	21,008,733
33 NPV of project at Plan Rate		\$83,992,720		NPV of Profit-Equity					
34									
35 Internal Rate of Return (IRR)		107%		This comfortably exceeds the MARR of 15%					

Fig. 27.5 Investment analysis

Net Present Value

Calculate the cash flow year by year for the project and use this to calculate the NPV of the project. Note that in the spreadsheet we have used “year zero” to hold the initial costs. In year zero the cash flow is $-\$20$ million, which is the equity invested, and in subsequent years the cash flow is given by:

$$\text{Cash Flow} = \text{Revenue} - \text{Cost} - \text{Repayments} - \text{Tax}$$

This is shown in row 32.

The NPV of the cash flow, including the initial equity input, is then calculated and shown at row 33.

The result is $\$83,992,720$. This is the value of the project. The calculations so far were carried out at the Planning Rate of 10 % interest. We see that the investment of $\$20$ million in equity produces a return of $\$83,992,720$ on this basis. This is clearly a good investment.

Internal Rate of Return

Our next step is to calculate the internal rate of return corresponding to the cash flows in row 32. We use the Excel IRR function and get the value of 107 %. This is shown at Cell B35. This confirms that this is an excellent investment and is well above the Minimum Acceptable Rate of Return (MARR) which was specified as 15 %.

Return on Investment

The value of the assets involved in the project vary over the period of the investment, starting at $\$50$ million and finishing at zero. Averaging these figures gives an average asset value of $\$25$ million. The annual profit is approximately $\$25$ million also, so the return on investment is about 100 % per annum. We have not formalized this in the spreadsheet as it is only a rough calculation.

Conclusion

The power station is a good investment. It has a short payback period, a substantial net present value in relation to the equity investment and an internal rate of return which is well above the hurdle rate. We should go ahead.

Chapter 28

Performance, Audit, and Review

Abstract The aim of this chapter is to introduce and to give examples of indicators of asset performance and to discuss auditing and review of the asset management system itself. *Outcomes* After reading this chapter you will be aware of the role of performance indicators and of some of the factors to consider in creating and applying them. You will have available some examples of performance indicators in specific applications. You will be aware of the need for audit of the asset management system and the requirement for review of the system to ensure its continuing effectiveness.

28.1 Key Performance Indicators^{1,2}

Key performance indicators are measurable quantities which are intended to show the extent to which a system is meeting the expectations which are placed on it. Performance indicators assist with:

- Providing a high-level indication of how well activities are being managed.
- Highlighting areas that need attention.

Performance indicators are used to measure the performance achievements of systems. They show how well an asset, or system of assets is meeting its stated purpose. They will usually relate to defined *levels of service*. They are therefore a valuable guideline for users, customers, and senior management in assessing and comparing performance across time periods and across comparable systems.

A range of performance measures suited to public works organizations is listed in the International Infrastructure Management Manual Sect. 2.2.3. Indicators may be linked to payments or to penalties in performance contracts. Responsibilities

¹ ISO 55001 Clause 6.2.1 Asset management objectives: “The organization shall establish asset management objectives...”

² ISO 55002 Clause 9.1.1.3. “A set of performance indicators should be developed to measure asset management activity and its outcomes.”

for nonconformance and constraints on performance need to be recognized in creating these contracts. At the operational level, performance indicators are useful to managers as rapid pointers to how a system is performing and as an indication of areas of strength and weakness.

Performance indicators should ideally be designed so that they do not affect the behavior of participants, other than in motivating genuine performance improvements. In practice, performance indicators can have a motivating or demotivating effect depending on how they affect particular people or groups. If maintenance work done while machinery is idle for operational reasons creates “unavailability” which counts against maintenance, then the maintenance opportunity will not be taken. If the cost of tires is charged to the operations budget, operators will have more motivation to drive carefully than if the cost comes out of the maintenance budget. Service providers can indulge in what is known as ‘*pencil whipping*’, which means making moves designed specifically to meet or beat the indicator. For example, a performance indicator on completed repair tasks may be circumvented by closing off one job ahead of a deadline and then starting up another job to finish the remaining work. Thus the danger of a performance indicator is that persons assessed on the basis of an indicator will work to the indicator, but not necessarily for the good of the systems as a whole.

Performance measures are subject to random variation, and to decide formally whether a variation is significant or not, statistical analysis, or at least, an awareness of statistical principles is needed.

Some examples of indicators are given in the following sections.

28.1.1 Railway System Indicators

In a railway system, some indicators are:

- % of planned train-kilometers delivered per month
- % of services no more than 5 min late
- Passenger-minutes late
- Train cancelations %
- Train-minutes late

28.1.2 Water Supply System Indicators

In a water supply system, performance is measured by such factors as reliability of supply, water quality, water pressure, frequency of burst water mains, sewer collapses, leaks and flooding, and response times and time to fix problems. Target levels of service for these parameters are set and performance is measured against them.

The severity of incidents can vary considerably and a severity rating should be established. The rating will also serve to indicate priority in addressing problems at any particular point in time. Examples of high severity events for a water authority are as follows:

- Sewer discharge or overflow
- Missing sewer access lid
- Sewage entering drain or watercourse
- Personal injury or significant health risk
- Damage to buildings or sensitive environments

28.1.3 Electricity Transmission or Distribution

Indicators of performance are:

- Outages frequency
- Outages duration
- System-minutes lost
- Voltage drops

The system-minutes lost is calculated by dividing the number of megawatt-minutes lost in a period by the average megawatt rating in the period. For example, if 40,000 megawatt-minutes were lost in a period, in a system that averaged 5,000 megawatts, the number of system-minutes lost would be 8.

Outages can be split into those which are “planned” and those which are “unplanned”. Planned outages occur when parts of the network are closed for refurbishment, upgrading, or replacement and customers are warned in advance of the intended shut down. The performance of the network is judged mainly on keeping the extent of unplanned outages to a low level.

28.1.4 Trucks

Examples of indicators are,

- Truck utilization.
- Numbers of used and unused trucks.
- Payload by weight, volume, and value.
- Distance traveled.
- Value per truck-day.
- Comparison with a base line.

It is important to distinguish between maintenance indicators and operations indicators.

28.2 Overall Equipment Effectiveness

$$\text{Overall Equipment Effectiveness} = \text{Availability} \times \text{Utilization} \times \text{Quality}$$

It is important to identify the sources of shortfalls. Availability may be high, but utilization poor, due to a range of factors, such as shortage of operators, shortage of materials, poor operational planning, and lack of demand. Similarly, the problems may lie in the quality area.

28.3 Maintenance-Related Performance Indicators

The following are some examples of items which can be used as a basis for performance indicators.

- a. Plant availability to be high
- b. Maintenance backlog in terms of numbers of work orders and total work load.
- c. Budgetary performance, actual versus planned maintenance costs
- d. Compliance with weekly maintenance plan, % of activities completed
- e. Response to approved work requests by numbers and times.
- f. Planned and scheduled hours as a % of total maintenance hours.
- g. Regulatory conformance as audited
- h. Unplanned downtime to be low
- i. Occupational Safety and Health injuries to be minimal
- j. Preventive Maintenance, Predictive Maintenance, and Condition-Based Maintenance hours as a % of all maintenance hours to be high
- k. Breakdown Maintenance Hours as a % of All Maintenance Hours to be low
- l. Production losses due to maintenance to be low
- m. Maintenance costs as a % of turnover
- n. Maintenance costs as a % of plant replacement value
- o. Work Orders Reworked/Total Work Orders
- p. Maintenance overtime/Total company overtime to be less than 5 %
- q. Inventory service level, % items met from stock.
- r. Inventory turnover to be 2–3 times/year
- s. Training, proportion of employees/year receiving training to be more than 40 %
- t. Expenditure on employees training to be more than 4 % of payroll
- u. Store investment as a % of plant replacement value
- v. Contractor costs as a % of maintenance costs
- w. Maintenance labor utilization to be high, but not so high that response to urgent jobs is inhibited.

28.4 Audit of the Asset Management System³

An audit is a process of checking a system to see whether the specified processes are being correctly followed and that the records in the system reflect the real assets and real events. Audits of the asset management system are required from time to time.

The results from an audit should form a basis for correcting any errors, omissions, or nonconformities. They can also form a basis for improvements in the system. Personnel working within the system should be encouraged to propose potential improvements.

Specific audit checks will include:

- Asset condition, availability, and suitability for purpose
- Compatibility of physical assets and the asset register
- Configuration management
- Stock taking
- Risk analysis and management status

28.5 Management Review⁴

A management review is a process of evaluating the asset management system to check its suitability and effectiveness in relation to the aims of asset management. Management reviews should be carried out from time to time.

Reviews should consider whether changes are needed in the asset management system, taking into account asset developments and the results of asset audits. Developments can include changes in the numbers or types of assets supported, technical and regulatory changes, and the performance of assets relative to key indicators.

Reviews may result in changes to resources, staffing, information systems, and roles and responsibilities of personnel. Reports of reviews should be retained for follow-up purposes.

³ ISO 55001 Clause 9.2 Internal audit: “The organization shall conduct internal audits...”

⁴ ISO 55001 Clause 9.3 Management Review: “Top management shall review the organization’s asset management system at ... intervals...”

Part VII
ISO 55000 Standard

Chapter 29

ISO 55000 Series Standards

Abstract The aim of this chapter is to provide a guide to the ISO 55000 series of Asset Management standards, published by the International Standards Association. *Outcomes* Reading this chapter will provide information on the requirements of the ISO 55000 series of standards and give cross-references to the relevant sections in this book and in other publications. This will help you in assessing, developing, and demonstrating the extent to which your organization complies with the standard.

29.1 Introduction

ISO 55000 series standards are standards which describe and specify requirements for the implementation of physical asset management in asset intensive organizations. This chapter provides a guide to the ISO 55000 series of standards. The Global Forum on Maintenance and Asset Management (GFMAM) has a certification scheme under the standard. For more information on this please contact your local asset management society, the web addresses of which are listed under web references in the Bibliography at the end of this book.

The ISO 55000 series of standards, like the ancient kingdom of Gaul, is divided into three parts. The document references are:

ISO 55000 Asset management—Overview, principles, and terminology. ISBN 978 0 580 86467 4

ISO 55001 Asset management. Management systems—Requirements. ISBN 978 0 580 75128 8

ISO 55002 Asset management. Management systems—Guidelines for the application of ISO 55001. ISBN 978 0 580 86468 1.

The roles of the three parts are summarized in Fig. 29.1.

ISO 55000 provides a general overview of asset management, a statement of fundamental principles, and a set of definitions of terms.

Fig. 29.1 The three parts of the ISO 55000 series of standards

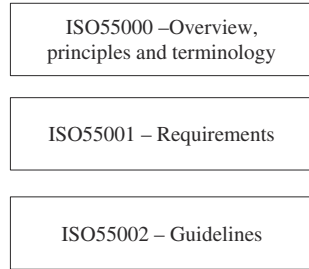

ISO 55001 contains a series of clauses which detail the *requirements* of the standard. There are “shall” clauses, stating what an organization needs to do to comply with the standard.

ISO 55002 contains clauses with the same headings as in ISO 55001. Under each heading it gives *guidelines* as to how the requirements of the corresponding clause of ISO 55001 should be implemented.

These standards provide a general framework for the management of physical assets. The adoption of ISO 55000 can provide:

- A structured view and understanding of asset management;
- Effective relationships between top management, asset management, operations, and maintenance;
- Improvements in asset financial returns;
- Well-informed asset management decisions;
- Insurance, health and safety, regulatory, and risk management benefits;
- Company recognition/marketing; and
- Improvements in training and development.

The ISO 5500 standards do not provide the specific detail of the many techniques involved in asset management. Besides knowing which techniques are relevant to any clause, we need the detail of that technique. This book, and the references and standards listed at the end of this book, present details of asset management techniques and procedures needed to implement an ISO 55000-based asset management system.

29.1.1 ISO 55000 Fundamentals

ISO 55000 lists the fundamentals on which asset management is based. These include an alignment between organizational and asset management objectives, the use of a lifecycle management approach, awareness of stakeholder needs, the use of a risk-based approach to decision making, and the integration of asset management with related functions including finance, human resources, logistics, operations, and information systems. Leadership and the definition of roles and responsibilities are emphasized. Key topics are planning, support, operations, performance evaluation, and continuous improvement.

29.1.2 ISO 55001 and ISO 55002

ISO 55001 Management Systems Requirements, details the requirements of the standard. ISO 55002 Management Systems Guidelines provides guidelines for the application of an asset management system based on ISO 55001. The clause headings in ISO 55001 and ISO 55002 are the same, so that each clause in ISO 55002 gives information about the implementation of the corresponding clause in ISO 55001. The clauses are considered in detail in the next section.

29.2 ISO 55001 Clauses and Book Cross-References

The requirements of the standard are indicated in ISO 55001. This section lists the clauses in ISO 55001, and for each one I quote a short extract in italics which indicates the primary intent of the clause. References are then given to sections of this book, and other documents or techniques, which can provide information to assist in meeting the requirements of the standard. Application guidelines are also provided in ISO 55002 under the same clause numbers.

1. **Scope**

This clause describes the scope of the standards.

2. **References**

A bibliography of general standards in the field is given in ISO 55000.

3. **Terms and definitions**

A list of terms and definitions given in ISO 55000, Clause 3. It is recommended that you use the same definitions. In your documentation, add extra terms and definitions which apply to your application, including abbreviations and acronyms.

4. **Context of the organization**

4.1 **Understanding the organization and its context**

The organization shall determine issues ... that affect ... its asset management system.
Asset management objectives ... shall be aligned to ... organizational objectives.

Relevant sections of this book are:

[1.5 Asset Management Role](#)

[1.7 What is Asset Management?](#)

[1.8 Aim of Asset Management](#)

[1.9 The Asset Life Cycle](#)

[1.10 Asset Management Basic Questions](#)

Figure [1.9](#) Asset management a gray area?

Figure [1.12](#) Business activities and asset management.

- 1.11 Dangers of Poor Asset Management
- 1.12 Benefits of Good Asset Management
- 2.1 Business Strategy and Asset Management
- Figure 2.1 Asset Management in the Business Context
- 2.2 Asset Management in the Organization
- Figure 2.2 Asset management in the organization
- Figure 11.2 Business and asset planning process overview
- Figure 11.3 In-service asset management, planning and budgeting
- 29.4 Strategic Asset Management Plan (SAMP)

Notes In the SAMP, give a background statement on external and internal issues that affect the asset management system. State organizational objectives (e.g., maximize profit, provide community service). Describe how asset management objectives are aligned with organizational objectives, quoting committee arrangements, and processes involved in this alignment.

4.2 Understanding the needs and expectations of stakeholders

The organization shall determine the stakeholders ... the expectations of these stakeholders...

Relevant sections of this book are:

- Figure 4.11 Stakeholder groups
- 4.12.1 Stakeholders
- 4.12.2 Stakeholder Examples
- 4.12.3 Existing Processes and the Status quo
- 3.1.1 Understanding Needs and Expectations of Stakeholders
- Figure 3.1 Asset management—a matrix activity
- 3.9.1 Communication and Response
- 4.5 Capability Requirements Planning
- Figure 4.5 Sources of development team representation
- 4.9 Feasibility Analysis
- 6.3 Business Case Outline
- 7.12 Project Progress Monitoring
- 7.17.1 Quiz Solution

In the SAMP, list stakeholders and outline their expectations.

4.3 Determining the scope of the asset management system

The organization shall determine the boundaries of the asset management system...

Relevant sections of this book are:

- Tables 2.2 and 2.3 Asset management activities
- 2.7 Asset Knowledge
- Chapter 9 Know Your Assets
- 9.1 Awareness of Key Assets.
- Figure 9.1 Mine site assets
- Figure 9.2 A railway asset summary

13.1 Information System Role and Applications

Figure 13.1 Asset management information system

Identify the range of assets to which the system applies. Use maps, diagrams, or Tables.

4.4 Asset management system

The organization shall establish ... an asset management system...

In the SAMP, identify the flow charts and organization charts that authorize and define the asset management system. Give references to the main documents used within the system.

Relevant sections of this book are:

Figure 2.1 Asset management in the business context

Figure 2.2 Asset management in the organization

Chapter 2 Structure and Activities

Chapter 3 Asset Management Personnel

Chapter 13 Asset Management Information Systems

Chapter 7 Implementing Development Plans

Chapter 11 Management of In-service Assets

Chapter 12 Capital Planning and Budget

Chapter 19 Maintenance Organization and Budget

The organization shall develop a SAMP...

Check the definition of the SAMP given in ISO 55000, Clause 3.3.2. It might be different from what you expect.

Relevant sections of this book are:

29.4 Strategic Asset Management Plan (SAMP)

5. Leadership

5.1 Leadership and commitment

Top management shall demonstrate leadership and commitment to the asset management system.

Relevant sections of this book are:

Figure 2.2 Asset management in the organization

2.3 Chief Asset Manager Role

Chapter 3 Asset Management Personnel

3.9. Leadership

13.3 Resourcing and Managing the System

Chapter 15 Risk Analysis and Risk Management

18.5 Continuous Improvement

18.6 Improvement Coordinator

Additional reference:

J.R. Lafraia and J. Hardwick, *Living Asset Management*. ISBN 978-1-922107-25-1.

Specific points mentioned in the standard include:

- Establishing consistent organizational and asset management objectives
- Integrating the asset management system into the business process
- Making resources available for asset management
- Promoting continuous improvement
- Managing risk

5.2 Policy

Top management shall establish an asset management policy.

An asset management policy statement is required.

Relevant sections in this book:

[2.9 Asset Management Policy](#)

Figure [2.7](#) An asset management policy statement

5.3 Organizational roles, responsibilities, and authorities

Top management shall assign the responsibility and authority for...

- Establishing the SAMP
- Meeting the requirements of the ISO 55000 series standard
- Ensuring the effectiveness of the asset management system
- Establishing asset management plans
- Reporting on asset management performance

Relevant sections in this book are:

Chapter [2](#) Structure and Activities

[2.2](#) Asset Management in the Organization

Figure [2.2](#) Asset management in the organization

[2.3](#) Chief Asset Manager Role

[2.5](#) Asset Management Groups

[3.5](#) Roles, Responsibilities and Authorities

[3.6](#) Engineering and Maintenance Roles

[7.10](#) Assigning Responsibilities

Figure [7.5](#) RACI chart

Chapter [28](#) Performance, Audit and Review

[28.4](#) Audit of the Asset Management System

[28.5](#) Management Review

[29.4](#) Strategic Asset management Plan (SAMP)

6. Planning

6.1 Actions to address risks and opportunities

The organization shall plan actions to address risks and opportunities...

Relevant sections in this book are:

Chapter 15 Risk Analysis and Risk Management

22.2.2 Risk-Based Inspection

The following are references to risk related techniques.

- ISO 31000 and ISO 31010. Risk analysis and risk management:
- IEC 60300-3-9. Risk analysis of technological systems:.
- IEC 61882:2002. Risk analysis in chemical plants and other high risk environments:
- IEC 61882 HAZOP—Hazard and Operability Studies. Standard: Hazard and Operability Studies Application Guide.
- API 580 and API 581 Risk-Based Inspection. Oil and gas industries.

Opportunities: Relevant sections in this book are:

1.9 The Asset Life Cycle

2.1 Business Strategy and Asset Management

2.8 Asset Management Activities

2.13.3 Holiday Resort Exercise

4.1 Project Initiation

6.3 Business Case Outline

Figure 11.3 In-service asset management, planning, and budgeting.

12.9 Capital Budgeting Cycle

13.1 Information System Role and Applications

14.6 Lost Opportunity Cost

6.2 Asset management objectives and planning to achieve them

6.2.1 Asset management objectives

The organization shall establish asset management objectives...

Relevant sections in this book are:

28.1 Key Performance Indicators

2.9 Asset Management Policy

5.4 Asset Investment Criteria

Chapter 14 Cost–Benefit Analysis

Chapter 23 Profit, Depreciation and Tax

Chapter 21 Reliability, Availability, and Maintainability

Chapter 22 Safety

6.2.2 Planning to achieve asset management objectives

The organization shall integrate planning to achieve asset management objectives with other ... planning activities...

Relevant sections in this book are:

- 2.10 Asset Management Plans
- Chapter 4 From Concept to Project Approval
- 4.3 Business Development Planning
- 4.5 Capability Requirements Planning
- 4.5.2 Demand Analysis and Forecasting
- 4.12 Considerations in Development Planning
- Chapter 5 Financial Methods
- Chapter 6 Developing a Business Case
- Chapter 7 Implementing Development Plans
- Chapter 8 Life Cycle Costing
- Chapter 10 Asset Continuity Planning
- Chapter 11 Management of In-service Assets
- Figure 11.3 In-service asset management, planning and budgeting.
- Chapter 12 Capital Planning and Budget
- Chapter 19 Maintenance Organization and Budget
- Chapter 16 Outsourcing
- Chapter 23 Profit Depreciation and Tax
- Chapter 14 Cost–Benefit Analysis
- Chapter 26 Equipment Replacement Decisions

The organization shall establish ... asset management plans...

Asset management plans are required.

Relevant sections in this book are:

- 4.3 Business Development Planning
- 4.5 Capability Requirements Planning
- 4.5.2 Demand Analysis and Forecasting
- 4.12 Considerations in Development Planning
- Chapter 6 Developing a Business Case
- Chapter 7 Implementing Development Plans
- Chapter 8 Life Cycle Costing
- Chapter 10 Asset Continuity Planning
- Chapter 11 Management of In-service Assets
- Chapter 12 Capital Planning and Budget
- Chapter 19 Maintenance Organization and Budget
- Chapter 14 Cost–Benefit Analysis
- Chapter 17 Logistic Support
- Chapter 26 Equipment Replacement Decisions

The organization shall ensure that ... risks are considered ... including contingency planning.

Relevant sections in this book are:

Chapter 15 Risk Analysis and Risk Management

7. Support

7.1 Resources

The organization shall determine and provide the resources needed for ... the asset management system.

Relevant sections in this book are:

Chapter 2 Structure and Activities

Chapter 3 Asset Management Personnel

Chapter 12 Capital Planning and Budget

Chapter 19 Maintenance Organization and Budget

7.2 Competence

The organization shall determine the necessary competence ... ensure ... persons are competent...

Relevant sections in this book are:

3.2 Competence

3.3 Required Areas of Competence

Figure 3.4 Spider diagram for competency analysis

Chapter 3 Asset Management Personnel

3.5. 3.6 Roles, Responsibilities, and Authorities

3.7 Personnel Development System

3.8 Competency Assessment

3.9 Leadership

7.14.2 Training

7.15 Change Management

7.3 Awareness

Persons ... shall be aware of ... policies ... benefits ... risks...

Relevant sections in this book are:

2.9 Asset Management Policy

Chapter 9 Know Your Assets

Chapter 15 Risk Analysis and Risk Management

Chapter 22 Safety

7.4 Communication

The organization shall determine the need for ... communications ... what ... when ... with whom ...how.

Relevant sections in this book are:

3.9.1 Communication and Response

7.5 Information requirements

The organization shall determine its information requirements...

The organization shall ... implement ... processes for managing its information.

Relevant sections in this book are:

Chapter 13 Asset Management Information Systems

13.1 Information System Role and Applications

Figure 13.1 Asset management information system

11.8 Configuration Management

The organization shall determine the requirements for alignment with financial ... terminology...

The organization shall ensure there is consistency ... between financial and technical data...

Relevant sections in this book are:

1.5 An Accountant's View of Assets

Chapter 5 Financial Methods

Chapter 6 Developing a Business Case

Chapter 23 Profit, Depreciation, and Tax

Chapter 27 Further Financial Topics

Chapter 14 Cost-Benefit Analysis

Chapter 24 Asset Decision Examples

Chapter 25 Economic Life

7.6 Documented information

7.6.1 General

The organization's asset management system shall include ... documented information...

Relevant sections in this book are:

Chapter 13 Asset Management Information Systems

13.1 Information System Role and Applications

Figure 13.1 Asset management information system

Traceable records to demonstrate conformance to the requirements of the asset management system include:

Asset register

Fault and failure records.

Maintenance action and cost records.

Asset history records.

Records of statutory compliance, e.g., pressure vessel tests.

Training records

Calibration records

7.6.2 [Documented information] Creating and Updating

...the organization shall ensure ... identification ... format ...approval...

Relevant sections in this book are:

Chapter 13: Asset Management Information Systems

13.3 Resourcing and Managing the System

13.5 Document Control

13.6 Implementing Changes

7.6.3 Control of documented information

Documented information ... shall be controlled...

Relevant sections in this book are:

Chapter 13 Asset Management Information Systems

13.3 Resourcing and Managing the System

13.5 Document Control

13.6 Implementing Changes

8. Operation

8.1 Operational planning and control

The organization shall ... implement processes ... to implement the ... asset management plans...

Relevant sections in this book are:

Chapter 4 From Concept to Project Approval

Chapter 10 Asset Continuity Planning

Chapter 11 Management of In-service Assets

Chapter 16 Outsourcing

Chapter 17 Logistic Support

Chapter 18 Asset Basic Care

Chapter 19 Maintenance Organization and Budget

Chapter 20 Stock Control

Chapter 26 Equipment Replacement Decisions

Chapter 24 Asset Decision Examples

8.2 Management of change

Risks associated with any planned ... change shall be assessed... The organization shall ensure that such risks are managed...

Relevant sections in this book are:

Chapter 7 Implementing Development plans

7.15 Change Management

8.3 Outsourcing

The organization shall ensure that outsourcing processes and activities are controlled.

Relevant sections in this book are:

Chapter 16 Outsourcing

9. Performance evaluation

9.1 Monitoring, measurement, analysis and evaluation

The organization shall determine ... shall evaluate and report on ... shall retain information ... meets the requirements of... [stakeholders].

Relevant sections in this book are:

28.1 Key Performance Indicators

18.4 Performance Recording

Chapter 21 Reliability, Availability, and Maintainability

21.8 Failure Reporting and Corrective Action System

21.11 Root Cause Analysis

Chapter 22 Safety

22.2.8 Record Keeping

9.2 Internal audit

The organization shall conduct internal audits...

Relevant sections in this book are:

28.4 Audit of the Asset Management System

Auditors and Procedures are to be Established

Audit Records are to be Maintained

Audit Follow-up Action Procedures are to be Established.

Actions Taken are to be Recorded

9.3 Management Review

Top management shall review the organization's asset management system at ... intervals...

Relevant sections in this book are:

28.5 Management Review

18.6 Improvement Coordinator

10. Improvement

10.1 Nonconformity and corrective action

When a nonconformity or incident occurs ... the organization shall ... react ... take action ... review ... make changes if necessary...

21.8 Failure Reporting and Corrective Action System (FRACAS)

9.5 Expert teams

Figure 9.6 Expert Team

Figure 18.3 Continuous improvement cycle

18.6 Improvement Coordinator

Figure 18.5 Workplace problem report

Chapter 21 Reliability, Availability, and Maintainability

21.3.1 Mean Time Between Failures

21.9 Pareto Analysis

21.10 Failure Mode and Effects Analysis (FMEA).

21.11 Root Cause Analysis

21.13 Reliability Centered Maintenance (RCM)

21.14 Maintenance Policy Review

21.20 Maintainability

Chapter 22 Safety

22.2.8 Record Keeping

10.2 Preventive action

The organization shall establish processes to ... identify potential failures...

21.12 Condition Monitoring

21.10 Failure Mode and Effects Analysis (FMEA).

21.13 Reliability Centered Maintenance (RCM)

22.2.2 Risk-Based Inspection (RBI)

9.4.1 Expert Teams

Figure 9.6 Expert team

21.11 Root Cause Analysis

10.3 Continual improvement

The organization shall continually improve...

18.5 Continuous Improvement

18.6 Improvement Coordinator

Figure 18.3 Continuous improvement cycle

Figure 18.4 Fishbone diagram

Figure 18.5 Workplace problem report

29.3 ISO 55001 Clauses and Figures

Table 29.1 gives a list of ISO 55001 clauses and Figures or Tables in this book which are relevant to each clause. This provides a simple visual insight into the main thrust of the clauses.

Table 29.1 ISO 55001 cross-reference summary

Clause	Topic	Related figures or tables
4.1	Understanding the organization and its context	Figure 1.12 Business activities and asset management Figure 2.1 Asset management in the business context
4.2	Understanding the needs and expectations of stakeholders	Figure 4.11 Stakeholder groups Figure 3.1 Asset management a matrix activity
4.3	Determining the scope of the asset management system	Table 2.1 Asset management knowledge Table 2.2 Asset management activities Figure 9.1 Mine site assets Figure 9.2 A railway asset summary
4.4	Asset management system	Figure 2.1 Asset management in the business context Figure 2.2 Asset management in the organization
5.1	Leadership and commitment	Figure 3.2 Areas of competence in asset management Figure 2.4 Asset management group structure
5.2	Policy	Figure 2.7 An asset management policy statement
5.3	Organizational roles, responsibilities, and authorities	Figures 2.2 and 2.3 Asset management in the organization Figure 7.5 RACI chart fro acquisition project
6.1	Actions to address risks and opportunities for the asset management system	Figure 15.1 Risk management outline Figure 15.9 Water supply risk documents
6.2.1	Asset management objectives	Figure 1.7, Chap. 28
6.2.2	Planning to achieve asset management objectives	Figure 4.3 Capability requirements planning Figure 11.3 In-service asset management planning and budgeting Figure 4.14 Steps in the asset management process
7.1	Resources	Figure 2.4 Asset management group structure Figure 3.2 Areas of competence in asset management
7.2	Competence	Figure 3.4 Spider diagram for competency analysis
7.3	Awareness	Table 2.1 Asset management knowledge
7.4	Communication	Figure 3.1 Asset management a matrix activity
7.5	Information requirements	Figure 13.1 Asset management information system
7.6	Documented information	Figure 19.7 Job planners check list
8.1	Operational planning and control	Figure 19.4 Data flows in the maintenance management application
8.2	Management of Change	Chapter 7, Sect. 7.15 Change management
8.3	Outsourcing	Chapter 16 Outsourcing
9	Performance evaluation	Chapter 28 Sect. 28.1 Key performance indicators

(continued)

Table 29.1 (continued)

Clause	Topic	Related figures or tables
9.1	Monitoring, measurement, analysis, and evaluation	Figure 21.8 Condition monitoring interval and delay time
9.2	Internal audit	Chapter 28, Sect. 28.4
9.3	Management review	Chapter 28, Sect. 28.5
10.1	Nonconformity and corrective action	Figure 21.1 In-service reliability management Figure 9.6 Expert team
10.2	Preventive action	Figure 19.1 Maintenance organization Figure 21.7 Condition monitoring techniques and medical parallels
10.3	Continual improvement	Figure 18.3 Continuous improvement cycle 18.6 Improvement coordinator Figure 18.4 Fishbone diagram Figure 18.5 Workplace problem report

29.4 Strategic Asset Management Plan (SAMP)

ISO 55001 at Clause 4.4 states that:

The organization shall develop a Strategic Asset Management Plan...

ISO 55000 at Clause 3.3.2 defines a Strategic Asset Management Plan, as follows:

Documented information that specifies how organizational objectives are to be converted into asset management objectives, the approach for developing asset management plans, and the role of the asset management system in supporting the achievement of asset management objectives.

The SAMP forms a basis for documenting compliance with ISO 55000.

- Indicates the organizational systems which address the requirements of the ISO 55000 standard.
- For accreditation under the standard, the clauses in the standard should be demonstrably addressed in practice. The process will be assisted if the SAMP follows the structure of the standard.

As a “strategic” document, the SAMP will normally refer to more detailed documents in specific areas, rather than containing all the information itself. However, it should provide an adequate indication of where the necessary features are detailed.

Note that ISO 55000, Clause 3.3.2 defines the SAMP is in a way which *entirely different* from its definition of “asset management plan” which is given in ISO 55000, Clause 3.3.3. Asset management plans in the definition of Clause 3.3.3 are considered in Chapter 9. The SAMP contains “how to” information on the asset management processes as a whole. However, the extent to which the SAMP and Asset Management Plans have material in common, or are merged or linked into a single document, is at the discretion of the organization.

29.5 SAMP Outline Contents

The following is a suggested outline of the contents of the SAMP. The first three sections form an introduction. Sections 29.4 to 29.10 follow the same as the headings and subheadings as in the ISO 55001 standard.

For a guide to the development of these sections, refer to the corresponding ISO 55001 clause numbers in this chapter at Sect. 29.5 and in ISO 55001/2 itself. The details under each clause should be expanded to provide information from your organization. References and a list of definitions and abbreviations are to be given in appendices.

1. Foreword
2. Executive summary
3. Vision and mission statements
4. Context of the organization
 - 4.1 Understanding the organization and its context
 - 4.2 Understanding the needs and expectations of stakeholders
 - 4.3 Determining the scope of the asset management system
 - 4.4 Asset management system
5. Leadership
 - 5.1 Leadership and commitment
 - 5.2 Policy
 - 5.3 Organizational roles, responsibilities, and authorities
6. Planning
 - 6.1 Actions to address risks and opportunities for the asset management system
 - 6.1.1 Asset management objectives
 - 6.1.2 Planning to achieve asset management objectives
7. Support
 - 7.1 Resources
 - 7.2 Competence
 - 7.3 Awareness
 - 7.4 Communication
 - 7.5 Information requirements
 - 7.6 Documented information
8. Operation
 - 8.1 Operational planning and control
 - 8.2 Management of change
 - 8.3 Outsourcing

- 9. Performance evaluation
 - 9.1 Monitoring, measurement, analysis, and evaluation
 - 9.2 Internal audit
 - 9.3 Management review
- 10. Improvement
 - 10.1 Nonconformity and corrective action
 - 10.2 Preventive action
 - 10.3 Continual improvement
- 11. Appendices
 - 11.1 Definitions
 - 11.2 Abbreviations and acronyms
 - 11.3 References

29.6 Functional Gap Analysis

An organization can check its status in relation to the standard, by comparing its systems with those indicated by the clauses of ISO 55001. The organization is likely to have in place many of the wide range of systems and techniques in recognized use for physical asset management. The aim of this table is to assist companies to assess their competence in relation to ISO 55001.

In Table 29.2, the first column gives the ISO 55001 clause numbers and clause heading, and the second column gives a brief description. As an example, consider

Table 29.2 ISO 55000 functional gap analysis template

ISO 55001 Clauses	Related techniques, activities, competencies	Target	Actual	Gap
4.1 Understanding the organization and its context	External and internal issues that affect the asset management system. Organizational objectives. How asset management objectives are aligned with organizational objectives. Reference the documents and processes involved in this alignment			
4.2 Understanding the needs and expectations of stakeholders	Identify stakeholders and their expectations			
4.3 Determining the scope of the asset management system	Identify the range of assets to which the asset management system applies			
4.4 Asset management system	Main documents, flowcharts, and organization charts that authorize and define the asset management system. Give the relevant documentary references and approvals			

(continued)

Table 29.2 (continued)

ISO 55001 Clauses	Related techniques, activities, competencies	Target	Actual	Gap
5.1 Leadership and commitment	Top management commitment to: Establishing consistent organizational and asset management objectives Integrating the asset management system into the business process Making resources available for asset management promoting continuous improvement managing risk			
5.2 Asset management policy	Policy stated, visibly endorsed by top management, communicated within the organization and available to stakeholders			
5.3 Organizational roles, responsibilities and authorities	Responsibility and authority assigned for a range of items including the following: Establishing the SAMP meeting the requirements of this standard ensuring the effectiveness of the asset management system establishing asset management plans reporting on asset management performance			
6.1 Actions to address risks and opportunities	Risk management methods established and applied. Asset development methods established and applied			
6.2.1 Asset management objectives	The objectives are documented in the SAMP and communicated to stakeholders			
6.2.2 Planning to achieve asset management objectives	Integrated planning to achieve asset management objectives aligned with other planning activities and business objectives			
7.1 Resources	Determination of resources needed. Provision of the resources needed for the asset management system			
7.2 Competence	Competence requirements determined for asset management jobs. Competence of appointees. Training requirements analysis. Training provision training budget			
7.3 Awareness	Personnel degree of awareness of policies and their benefits risks implications. Asset knowledge. Technical regulation awareness regulation compliance for: High risk plant environment; Health and safety. Legal support for acquisitions and contracting			
7.4 Communication	Appropriateness and effectiveness of communications employee communication systems, e.g., newsletters, meetings. Stakeholder groups creation, planning, and implementation			
7.5 Information requirements	Asset management information system in operation. Resourcing. Asset register, coding, maintenance policies, and procedures in system. Data quality Real-time use. History. Configuration management organization for the security and access to documentation. Data coordinator data custodian to check and approve. Procedures for the revision of documents alignment between technical and financial data			

(continued)

Table 29.2 (continued)

ISO 55001 Clauses	Related techniques, activities, competencies	Target	Actual	Gap
7.6 Documented information	Production records. Fault and failure records. Maintenance action and cost records. Asset history records. Records of statutory compliance, e.g., pressure vessel tests. Training records calibration records			
8.1 Operational planning and control	Asset continuity planning management of in-service assets			
8.2 Management of change	Management of change systems in place and applied			
8.3 Outsourcing	Establishment and management of outsourcing			
9.1 Performance monitoring, measurement, analysis and evaluation	Key Performance indicators established as required. Performance monitoring, procedures, standards, implementation, and response. Reliability standards and performance monitoring			
9.2 Internal audit	Auditors and procedures established audit records maintained audit follow-up action procedures established. Actions recorded			
9.3 Management review	Reviews of the asset management system occurring. Resources adequate. Systems responding to changes in asset types or needs. Improvement coordinator role and responsibilities. Suggestion, review, and feedback systems			
10.1 Nonconformity and corrective action	Incident reporting systems. Incident management systems and practices. Failure reporting and Corrective Action Systems (FRACAS). Suggestion, response, and feedback systems. Root Cause Analysis. Failure Mode and Effects Analysis (FMEA). Reliability analysis, MTBF, failure rate trends Maintainability analysis and improvement			
10.2 Preventive action	Preventive maintenance established and applied. Condition monitoring techniques used where appropriate. Condition monitoring economics, methods, targets, effectiveness. Condition monitoring personnel, training, procedures, and response systems. Engineering design review. External technical support where required			
10.3 Continual improvement	Plan, do, check, and act. Improvement coordinator role and responsibilities. Suggestion, review, and feedback systems			
	Totals			
	% Actual/Target			
Notes—scoring				
5 = Very good				
4 = Good				

(continued)

Table 29.2 (continued)

ISO 55001 Clauses	Related techniques, activities, competencies	Target	Actual	Gap
3 = Moderate				
2 = Developing				
1 = Initial				
0 = None				

Clause 7.5 Information Requirements. The requirement for an asset management information system will typically be met by having a computerized asset management information system. Thus Table 29.2 shows “asset information management system in operation” as the first listed requirement relevant to this clause. The three right-hand columns of the table provide for the user to assess the level of competency targeted and achieved, and whether the targeted level has been attained.

Table 29.3 ISO 55000 Buzz-word generator

Achieve	Regulatory	Alignment
Align	Demonstrated	Compliance
Authorize	Tangible	Context
Contribute	Communicated	Expectations
Demonstrate	Effective	Culture
Enable	Normative	Decisions
Enhance	Sustainable	Governance
Ensure	Workplace	Objectives
Implement	Operating	Outputs
Integrate	Stakeholder	Performance
Lead	Informed	Policy
Manage	Risk-based	Processes
Outsource	Organizational	Responsibilities
Realize	Managed	Risk
Specify	Responsible	Scope
Communicate	Continuous	Systems
Sustain	Cross-functional	Stakeholders
Transform	Continual	Sustainability
Undertake	Improved	Values
Evaluate	Relevant	Awareness
Support	Legislative	Commitments
Leverage	Intangible	Benefits
Control	Environmental	Opportunities
Influence	Asset-related	Factors
Monitor	Strategic	Improvement
Assess	Empowered	Resources
Create	Information-driven	Competence
Develop	Policy-driven	Strategy
Promote	Compatible	Interaction

The company's level of competency in relation to any clause is judged by reference to five levels which are listed at the end of Table 29.2. These are Mastery (score 5), Professional (4), Foundation (3), Developing (2), Initial (1), and None (0). The fourth column in Table 29.2, headed Target, is for the user to select a target level which the company wishes to achieve in relation to a particular technique. While Mastery (5) would be ideal for every competency, not all companies will require the same level of competency in every technique or every clause.

As an example, again consider clause 7.5 Information Requirements. The second competency under this clause is "Resourcing." The target set by the company for this competency might be Professional (4), that is, we wish to have adequate, well-trained, and professionally competent staff to support our asset management information system. If the company has in fact minimal resources in this area, possibly also with system training yet to be completed, then its actual level of attainment might be assessed as Initial (1) or Developing (2). The Attained column would then contain the entry "0" since the target level of competence has not been reached.

Assessment of the company's competence in relation to the target levels can be continued across all clauses of ISO 55001, with Actual and Attained levels being entered in the Table. Finally, a total score can be calculated in terms of both percentage of Actual to Target and of the number of competencies attained.

29.7 Buzz-Word Generator

Have fun while developing your ISO 55000 documentation. Select one word at random from each column to make your own ISO 55000 buzz-word.

Appendix

See Tables A.1 and A.2.

Table A.1 Discount factor $(1/(1 + r))^n$

Years, No. n	Interest rate, r										
	5 %	6 %	7 %	8 %	9 %	10 %	11 %	12 %	13 %	15 %	20 %
1	0.9524	0.9434	0.9346	0.9259	0.9174	0.9091	0.9009	0.8929	0.8850	0.8696	0.8333
2	0.9070	0.8900	0.8734	0.8573	0.8417	0.8264	0.8116	0.7972	0.7831	0.7561	0.6944
3	0.8638	0.8396	0.8163	0.7938	0.7722	0.7513	0.7312	0.7118	0.6931	0.6575	0.5787
4	0.8227	0.7921	0.7629	0.7350	0.7084	0.6830	0.6587	0.6355	0.6133	0.5718	0.4823
5	0.7835	0.7473	0.7130	0.6806	0.6499	0.6209	0.5935	0.5674	0.5428	0.4972	0.4019

Table A.2 Annuity factor $(1 - ((1/(1 + r))^n))/r$

Years, No. n	Interest rate, r										
	4 %	5 %	6 %	7 %	8 %	9 %	10 %	11 %	12 %	13 %	20 %
1	0.9615	0.9524	0.9434	0.9346	0.9259	0.9174	0.9091	0.9009	0.8929	0.8850	0.8333
2	1.8861	1.8594	1.8334	1.8080	1.7833	1.7591	1.7355	1.7125	1.6901	1.6681	1.5278
3	2.7751	2.7232	2.6730	2.6243	2.5771	2.5313	2.4869	2.4437	2.4018	2.3612	2.1065
4	3.6299	3.5460	3.4651	3.3872	3.3121	3.2397	3.1699	3.1024	3.0373	2.9745	2.5887
5	4.4518	4.3295	4.2124	4.1002	3.9927	3.8897	3.7908	3.6959	3.6048	3.5172	2.9906

Bibliography

- Bentley, J. P. (1998). *An introduction to reliability and quality engineering*. Longman Scientific and Technical.
- Bierman, H., Jr. & Smidt, S. (2006). *The capital budgeting decision*. Maxwell Macmillan International Editions.
- Blanchard, B. S. (1992). *Logistics engineering and management* (4th ed.). Prentice-Hall International.
- Blanchard, B. S., & Lowery, E. E. (1995). *Maintainability*. New York: McGraw-Hill.
- Blank, L. T., & Tarquin, A. J. (1998). *Engineering economy* (4th ed.). New York: McGraw-Hill. ISBN 0-07-063110-7.
- Blischke, W. R., & Murthy, D. N. P. (2003). *Case studies in reliability and maintenance*. New York: Wiley.
- Bloch, H. P., & Geitner, F. K. (1998). *Machinery failure analysis and troubleshooting* (2nd ed.). Gulf Publishing Co, Texas.
- Campbell, J. D. (2006). *Uptime—strategies for excellence in maintenance management*. Productivity Press.
- Campbell, J. D., & Jardine, A. K. S. (2001). *Maintenance excellence*. New York: Marcel Dekker, Inc.
- Canada, J. R., & White, J. A., Jr. (1980). *Capital investment decision analysis for management and engineering*. Prentice-Hall.
- Chemical Process Safety, Center for. “Guidelines for Chemical Process Quantitative Risk Analysis.” And “Guidelines for Process Equipment Reliability Data” with data tables.
- Collacott, R. A. (1977). *Mechanical fault diagnosis*. London: Chapman and Hall. ISBN 0 412 12930 2.
- Competency Requirements for the management of physical assets and infrastructure. Institute for Asset Management, 221 St Johns Street, London EC1V 4JY, UK. <http://www.iam-uk.org>.
- Damodaran, A. (2002). *Investment valuation* (2nd ed.). New York: Wiley. ISBN 0-471-41488-3.
- Gano, D. L. (2003). *Apollo root cause analysis* (2nd ed.). Yakima, Washington: Apollonian Publications. ISBN 1-883677-01-7.
- Hartmann, E. H. (1992). *Successfully installing TPM in a Non-Japanese plant*. New York: TPM Press Inc.
- Hastings, N. A. J. (2003). Component reliability, replacement and cost analysis with incomplete failure data. Chapter 16. In W. R. Blischke, & D. N. Prabhakar Murthy (Eds.), *Case studies in reliability and maintenance*. New Jersey: Wiley.
- Higgins, L. R. (2008). *Maintenance engineering handbook* (5th ed.). New York: McGraw-Hill Inc.
- Hodges, N. W. (1996). *The economic management of physical assets*. London: Mechanical Engineering Publications Ltd.

- International Infrastructure Management Manual. (2011). Association of Local Government Engineering NZ Inc. P.O. Box 118, Thames, New Zealand. www.ingenium.org.nz.
- Ishikawa, K. (1982). *Guide to quality control*. Asian Productivity Organization.
- Jardine, A. K. S., & Tsang, A. H. C. (2006). *Maintenance, replacement and reliability*. New York: Taylor and Francis.
- Juran, J. M., & Gryna, F. M. *Juran's quality control handbook* (4th ed.). New York: McGraw-Hill Inc.
- Kelly, A. (2006). "Plant Maintenance Management", 3 volumes: "Strategic Maintenance Management", "Managing Maintenance Resources", "Maintenance Systems and Documentation". Butterworths-Heinemann.
- Knights, P., Jullian, F., & Jofre, L. (2006). *Building business cases for maintenance improvement projects*. International Mine Management Conference, Melbourne.
- Lawless, J. F. (1982). *Statistical models and methods for lifetime data*. Wiley.
- Levitt, J. (2004). *Managing maintenance shutdowns and outages*. New York: Industrial Press Inc. ISBN 0-8311-3173-X.
- Mann, L. (1983). *Maintenance management*. New York: Lexington Books. ISBN 0-669-04715-5.
- Mannan, S. (Ed.). (2005). *Lees' loss prevention in the process industries—hazard identification assessment and control* (3rd ed., Vol. 3). Amsterdam: Elsevier, Butterworth, Heinemann.
- Moubray, J. (1997). *Reliability-centered maintenance*. New York: Industrial Press.
- Neale, M. J. (Ed.). (1995). *Component failures maintenance and repair*. Oxford: Butterworth Heinemann.
- Nyman, D., & Levitt, J. (2001). *Maintenance planning, scheduling and coordination*. New York: Industrial Press Inc. ISBN 0-8311-3143-8.
- O'Connor, P. D. T. (2002). *Practical reliability engineering* (4th ed.). New York: Wiley.
- Peterson, R., & Silver, E. (1998). *Decision systems for inventory and production planning*. New York: Wiley.
- PMBOK guide. A guide to the project management body of knowledge. Project Management Institute Inc. Newton Square PA, USA. ISBN 1-930699-45-X.
- Reason, J., & Hobbs, A. (2003). *Managing maintenance error*. Hampshire: Ashgate publishing.
- Sherwin, D. J., & Bossche, A. (1993). *The reliability, availability and productiveness of systems*. Chapman & Hall.
- Smith, A. M., & Hinchcliffe Glen R. (2004). *RCM—gateway to world class maintenance*. Oxford: Elsevier. ISBN 0-7506-7461-X.
- Smith, D. J. (1993). *Reliability maintainability and risk* (4th ed.). Oxford: Butterworth-Heinemann.
- Stapelberg, R. F. (2009). *Handbook of reliability, availability, maintainability and safety in engineering design*. London: Springer.
- Suzuki, T. (1994). *Total productive maintenance in process industry*. Portland, USA: Productivity Press.

Web References

- <http://www.api-u.org> (American Petroleum University) Oil and Gas Industry.
- <http://www.maintenancejournal.com.au> (Asset Management and Maintenance Journal).
- <http://www.assist.daps.dla.mil> (Military Standards).
- <http://www.bsi-global.com> (British standards).
- RIAC U.S. Department of Defense Reliability Information Analysis Center.

International organizations:

- GFMAM Global Framework in Maintenance and Asset Management.
Australia: Asset Management Council. amcouncil.com.
- Brazil: abraman.abraman.org.br.

Canada: PEMAC. pemac.org.
 Europe: EFNMS. efnms.org.
 South Africa: SAAMA. saama.org.za.
 USA: SMRP. smrp.org.

Standards

API 510—Pressure Vessel Inspection Code.
 API 570—Piping Inspection Code.
 API 580 and API 581—Risk Based Inspection.
 AS 1200:2000 Pressure Equipment.
 AS 3788:2001 Pressure Equipment In-service Inspection.
 AS 4343:1999 Pressure Equipment—Hazard Levels.
 AS 4360—Risk Analysis and Management.
 AS 4536—Life Cycle Costing.
 AS 4801—Occupational Health and Safety.
 ATA MSG-3—Air Transport Association Maintenance Steering Group.
 BS 5760—Failure Mode and Effects Analysis.
 BS 18001—Occupational Health and Safety.
 CSA Z662—Oil and Gas Pipeline Systems.
 IEC 60300—Dependability Series.
 -3-3 Life Cycle Costing.
 -3-10 Maintainability.
 -3-11 Reliability Centered Maintenance.
 -3-12 Integrated Logistic Support.
 IEC 60812 Failure Mode and Effects Analysis.
 IEC 61511-1 Functional safety, Safety Instrumented Systems.
 IEEE C57.12.00 General Requirements for... Transformers.
 IEEE C57.12.90 Test Code for... Transformers.
 ISO 10007 Quality Management Systems, Configuration management.
 ISO 15288 Systems Engineering—Systems Life Cycle Processes.
 ISO 17776 Oil and Gas Offshore Production Installations.
 ISO55000 Asset management. Overview, principles and terminology. ISBN: 978 0 580 86467 4.
 ISO55001 Asset management. Management systems—Requirements. ISBN: 978 0 580 75128 8.
 ISO55002 Asset management. Management systems—Guidelines for the application of ISO55001. ISBN: 978 0 580 86468 1.
 JAE1011. Reliability Centered Maintenance. Society of Automotive Engineers.
 MIL-STD-1388-2B. Integrated Logistic Support.
 SAE J 817-2 Maintainability Index;
 SAE JA1010 Maintainability Program;

Organizational abbreviations:

API = American Petroleum Institute.
 AS = Australian Standard.
 ATA = Air Transport Association.
 BS = British Standard.
 IEC = International Electrotechnical Commission.
 IEEE = Inst. Of Electrical and Electronic Engineers.
 ISO = International Standards Organization.
 JAE = Journal of the Society of Automotive Engineers.
 PAS = Publicly Available Specification.

Index

A

ABC analysis, 362
Acceptance, 83, 129, 130, 132, 141, 243, 293, 374, 379, 414, 420
Acquisition, 8, 21, 27, 30, 35, 62–64, 71–74, 79, 81, 82, 86–88, 102, 113, 121, 125, 127, 132, 134, 144, 146, 149, 150, 152, 155, 157, 158, 164, 175–180, 182, 188, 211, 263, 288, 294, 344, 374, 375, 443, 456, 457, 466, 470, 473
Acquisition cost, 90, 97, 98, 131, 150, 178, 286, 430–433, 435–439, 456, 457, 459, 466, 470, 473, 484, 485, 494
Acquisition strategy, 75, 81, 88, 90, 145, 179
Activity, 36, 43, 44, 113, 228, 230, 233, 243, 244, 247, 296, 319, 320, 337, 339, 340
Activity based cost–benefit, 243, 244, 247
Activity based costing, 243, 296, 337, 340
Alliance, 277
American Petroleum Institute, 251, 417, 418, 423, 425
Annualized
 cost, 467, 482
Annuity factor, 93, 100, 101, 450, 477, 479, 527
Approved development plan, 120
Assembly replacement, 231, 470
Asset
 life cycle, 7, 11, 12, 17, 19, 21, 33
 mine site, 162, 163, 508
 register, 34, 162, 174, 224, 226, 227, 232, 501
Asset basic care, 304, 305, 307, 312, 314
Asset development portfolio, 125
Asset group manager, 31
Asset management
 activities, 6, 28, 29, 32, 33, 34, 56, 497

 definition, 10, 11
 group, 29, 30
 information system, 162, 223
 knowledge, 31, 32
 plans, 36
 role, 7
 system, 11
Asset manager, 7, 14, 27, 28, 32, 44, 48, 53, 126, 161, 216, 252, 275, 279, 464, 484, 485, 491
Asset register, 34, 162, 174, 224, 226, 227, 232, 501, 522
Audit, 52, 269, 279, 388, 411, 497, 501, 519, 523
Authorities, 44, 50, 175, 251, 430, 455, 483, 490, 510
Availability, 3, 14, 44, 65, 80, 81, 90, 97, 101, 115, 118, 121, 130, 150, 170, 210, 217, 278, 294, 317, 327, 339, 357, 373, 375, 398–402, 407, 410, 448, 472, 500

B

Backlog, 161, 162, 168, 194, 196, 326, 328, 329, 336–348, 340, 348, 371, 463, 500
Backorder, 348, 371
Balance sheet, 7, 10, 81, 124, 210, 239, 364
Benefit
 non-financial, 116, 239, 240
Block diagram, 162, 164–166, 169, 170, 263
Book value, 162, 430–433, 437, 439, 440, 446, 465, 470, 485, 486
Bottleneck, 42, 118, 162, 167, 168, 170, 171, 207
Bottom up, 62, 64, 193, 202, 203
Breakeven analysis, 489

- Budget
 - monitoring, 335, 336
 - report, 336
 - time horizon, 193, 209
- Budget expenditure, 209, 230, 235
- Budgeting
 - zero-based, 326, 327, 339
- Build own operate transfer, 271, 281
- Buildings, 7, 8, 14, 20, 21, 94, 154, 169, 201, 225, 254, 337, 423, 429, 430, 439, 489, 499
- Bulls-eye chart, 139
- Business case, 13, 45, 85, 89, 94, 113–115, 117–120, 122, 124, 127, 157, 195
- Business development, 28, 31, 35, 41, 48, 61–63, 65, 67, 74, 82, 85, 120, 127, 137, 210
- Business development group, 28, 31, 41, 63, 67
- Business organization, 25
- Business plan, 11, 35, 48, 53, 56, 67, 69, 122, 193, 326, 327
- Business planning, 44, 56, 122
- Business strategy, 25, 40, 41, 194

- C**
- Cannibalization, 130, 357, 358
- Capability
 - continuity planning, 182
 - requirements planning, 66, 70, 210
- Capability gap, 32, 67, 71–73, 86, 115, 121
- Capability gap analysis, 32, 61, 67, 72, 86, 115, 121
- Capability requirements statement, 67, 72, 73, 78, 121, 126
- CAPEX, 8, 13, 35, 47, 123, 184, 192, 194, 197, 208, 209, 219, 220, 446
- Capital
 - transaction, 429, 439
- Capital budget
 - cycle, 213, 217
 - current year, 218
- Capital expenditure program, 210, 211
- Capital planning, 13, 207, 210, 212, 218
- Capital project portfolio, 207, 217
- Capital rationing, 184, 207, 213, 214, 219, 222
- Capital recovery factor, 93, 101
- Capital requirement, 177, 178, 181, 207, 212–214, 288, 294
- Cash cow, 17, 123
- Cash flow, 94, 96, 105
- Cash flow after tax, 437
- Cash flow diagram, 94, 96, 108, 437, 438, 443, 445, 459
- Cataloguing, 344, 345
- Challenger, 467–469
- Change control, 201
- Change management, 142, 143
- Chief asset manager, 27, 28, 40, 44, 48, 53, 188
- Code
 - activity, 230
 - trade, 228, 230
- Coding, 225, 228
- Commissioning, 139–141
- Commonality, 130, 131
- Common law, 254
- Communication, 7, 22, 54, 65, 94, 103, 106, 109, 318, 353, 397, 491
- Communications system, 103, 106, 109
- Company tax, 429, 433, 435–437, 460, 493
- Competence, 13, 45–47, 413, 525
- Competency, 45, 52, 308, 413, 525
- Component replacement, 192, 231, 319, 410, 476
- Condition, 11, 13, 19, 31, 36, 55, 118, 151, 168, 159, 387, 389–392, 476
- Condition monitoring, 34, 83, 189, 91, 240, 68, 303, 308, 318, 319, 329, 339, 376, 380, 389, 390–392, 396, 398, 402, 466, 476, 519, 523
- Condition monitoring effectiveness, 391
- Configuration management, 32, 34, 46, 49, 83, 187, 189, 194, 200, 201–204, 224, 293, 295, 296, 300, 501, 514, 522
- Consequence, 115, 190, 209, 249, 251, 257–259, 265, 269, 270, 360, 377, 381, 471, 472, 473, 475, 476
- Consignment, 356, 363
- Consolidated asset management plan, 187, 193, 195, 196, 211
- Contingency allowance, 76, 219, 249, 260, 261, 301, 337, 338
- Contingency plan, 47, 137, 141, 165, 249, 252, 260, 261, 267, 268–270, 360, 376, 400, 513
- Contingency planning, 47, 249, 260, 270, 400, 513
- Continuity planning, 13, 71, 174, 175, 176, 182–184, 188, 210
- Continuous improvement, 36, 62, 189, 202, 276, 278, 303, 308, 309, 310, 313, 315, 506, 510
- Contract, 14, 21, 30, 31, 41, 49, 50, 51, 52, 80, 82, 83, 88, 188, 128, 129, 131, 133,

136, 150, 151, 188, 189, 204, 254, 255,
260, 263, 270, 271, 273, 275–280, 288,
291, 294, 296, 297, 300, 367, 474

Contractor viewpoint, 271, 280, 295

Cost–benefit analysis, 35, 239, 241,
242–246, 248

Cost control, 275, 335

Cost driver, 337

Costing, 49, 74, 80, 87, 88, 131, 149, 151,
152, 155, 157, 158, 192, 224, 243, 275,
287, 289, 296, 321, 322, 334, 337, 338,
340, 455, 466, 467, 477, 484

Cost of failure, 119, 374, 400, 476

Criticality, 161, 162, 164–166, 169, 170,
194, 215, 216, 328, 345, 354, 359,
360, 383, 466

Current asset, 8, 9, 19, 20, 69, 213, 269,
363, 365

D

Danger sign, 328

Data administration, 229, 234

Date of decision, 75, 79, 83, 84, 87, 117, 148

Days supply
report, 361

Death spiral, 3, 17, 18, 22, 47, 64, 123, 464

Debt, 481, 492, 493

Decision criteria, 72, 121, 124

Decision support, 13

Deeper maintenance, 188, 189, 202, 288, 290,
297, 303, 319, 469

Defender, 467

Delegation, 64, 65, 210, 399

Demand
dependent, 349, 371
independent, 371
management, 69, 194

Deployed assets, 33, 41, 161, 187, 188,
190, 293

Depreciation
declining balance, 432, 433, 460
straight line, 336, 431, 432, 435, 439, 440,
446, 486, 492

Deprivation value, 486

Development plan, 13, 48, 61, 67, 72–75, 78,
81, 82, 114, 115, 120, 125, 128, 144,
145, 210

Development planning, 61–63, 65, 67–69,
76, 162

Development planning team, 61, 63, 67, 68

Devolution of authority, 209

Discounted cash flow, 93–95, 103, 105, 113,
441, 442, 449, 450, 455, 461, 487

Discount factor, 93–97, 103, 105, 263, 450,
452, 459, 478, 479

Disposal, 3, 8, 11, 12, 17, 21, 25, 26, 29, 33,
41, 71, 75, 79, 82, 83, 97, 129, 152,
154, 155, 173, 174, 178, 179, 181, 183,
185, 188, 190, 194, 195, 278, 285, 286,
296, 300, 301, 306, 329, 349, 432, 443,
477

Disposal portfolio, 125–127, 145

Document control, 52, 231

Downtime
cost of, 117, 118, 400, 407, 410

Drawings, 165, 200, 292, 322, 404, 424

Dues in, 343, 347, 348, 350, 355, 356, 361,
368, 370, 371

Dues out, 343, 347, 348, 350, 355, 356, 361,
368, 370, 371

Duty of care, 249, 253, 254

E

Economic life
analysis, 457, 460, 461

Effective life, 430–432, 435, 437, 439, 440,
446, 485, 486

Electricity transmission, 30, 31, 48, 155,
163, 214, 221, 227, 240, 288, 471,
473, 477, 499

Engineer, 7, 30, 167, 169, 205, 261, 318, 329

Engineering, 4, 7, 19, 20, 25, 28, 30, 31, 41,
44–46, 48–50, 56, 66, 72, 77, 81, 143,
152, 153, 155, 165, 190, 191, 205, 214,
242, 253, 262, 272, 286, 292, 293, 294,
322, 333, 347, 373, 392, 393, 397, 413,
416, 423, 424, 426

Engineering leaders, 50

Engineering roles, 50

Environmental, 7, 11, 13, 21, 36, 42, 62, 79,
86, 88, 116, 117, 130, 132, 151, 165,
213, 216, 217, 239, 240, 241, 257, 263,
287, 300, 313, 374, 388, 395, 465, 473,
476, 485, 524

Equipment
ageing, 470
risk–cost, 464

Equipment effectiveness, 500

Equipment replacement, 26, 120, 297, 309,
389, 396, 410, 455, 463, 464, 465, 466,
470

Equipment selection and trial, 132

Equity, 10, 481, 492, 493–496

Equivalent Annual Cost (EAC), 93, 94, 98,
100, 105, 152, 155, 158, 443–447, 449,
450, 452, 455, 458–462, 466, 467, 478

- Equivalent Annual Value (EAV), 98
 - Equivalent Unit Cost (EUC), 93, 101
 - Event tree, 422
 - Excel function
 - NPV, 97, 98
 - PMT, 99
 - IRR, 102, 103
 - PV, 451, 452
 - Executive summary, 115, 117, 136, 198, 520
 - Exercise
 - asset data setup, 232, 234
 - availability related to total time, 401, 402, 407, 410
 - bottling plant, 85, 90
 - capacity planning, 89
 - cost of downtime, 117, 118, 400, 407, 410
 - holiday resort, 40, 42, 511
 - level of repair analysis, 299, 301
 - logistic support analysis, 298, 299, 301
 - long river ferry, 219, 222
 - maintenance budgeting, 338, 340
 - Pacific Earth Moving Part 1, 55, 56
 - Pacific Earth Moving Part 2, 122, 124
 - Pacific Earth Moving Part 3, 144, 146
 - Pacific Earth Moving Part 5, 338, 341
 - Pacific Earth Moving Part 6, 410
 - plant criticality, 169, 170
 - racing cycle team, 299
 - regional health clinic, 245, 246
 - solar or diesel power, 449, 452
 - spend–limit, 478, 480
 - standby generator, 449, 450
 - transformer replacement, 477, 479
 - turbo–generator, 107, 111
 - vehicle fleet capacity, 183, 184
 - water pump replacement, 164
 - Expense, 8, 9, 72, 107, 131, 208, 231, 365, 366, 433, 434, 438, 440, 446, 449, 491
 - Expert team, 161, 167, 399, 519
 - Expiry, 87, 175–177, 182–184
 - Exponential smoothing, 353
- F**
- Failure
 - pattern, 377, 378, 381, 390, 473
 - rate, 374, 377, 380, 466, 472, 476, 477
 - reporting, 318, 523
 - Failure frequency, 231
 - Failure mode and effects analysis, 257, 262, 375, 383
 - Failure Reporting and Corrective Action System, 382, 523
 - Fault tree, 262, 263, 422
- Feasibility analysis, 32, 63, 73, 74, 79, 84, 86, 88–90, 114, 121, 127, 151
 - Financial
 - report, 224
 - Financial analysis, 6, 42, 46, 81, 90, 94, 107, 111, 195, 262, 449, 471, 492
 - Fitness for service, 165, 423
 - Five whys, 386
 - Fixed asset, 8–10, 19, 94, 208, 221, 363, 429, 433, 435, 437, 439, 440, 487
 - Fixed cost, 274, 282, 473, 488, 489, 490, 494
 - Fixed plant, 225, 293
 - Fleet, 13, 15, 32, 33, 118, 174, 178, 180, 183, 184, 187, 192, 200, 205, 214, 219, 224, 287, 289, 291, 295, 301, 327, 338, 349, 365, 407
 - FMEA, 257, 262, 375, 383, 410, 523
 - Forecast, 42, 48, 63, 70, 81, 84, 89, 117, 119, 120, 135, 136, 194, 231, 256, 338, 353, 401, 464, 469, 495
 - Forecasting, 46, 66, 68, 83, 84, 87, 231, 344, 352
 - FRACAS, 54, 377, 382, 384, 410, 523
 - Function, 80, 97, 99, 102, 109, 127, 130, 165, 167, 187, 225, 234, 265, 320, 332, 389, 394, 395, 488, 494, 521
 - Functional location, 225, 226, 228
 - Future value, 493, 474, 477, 484, 486
- G**
- Gap analysis, 32, 33, 72, 84, 115, 173, 178, 521
 - Gearing, 481, 492, 493
 - Goodwill, 7, 118, 119
- H**
- Hazard, 141, 251, 253, 257
 - Hazard analysis, 251, 257, 265
 - Hazard and Operability Analysis, 257
 - HAZOP, 257, 511
 - Health and safety, 17, 22, 66, 88, 142, 278, 506
 - Historical cost, 483
 - Housekeeping, 240, 307, 308, 312, 388
- I**
- Imbalance, 34, 274, 334
 - Implementation portfolio, 82, 83, 127, 144
 - Improvement coordinator, 311, 314, 519
 - Inflation, 483, 484, 491

- Information system, 11, 26, 34, 35, 162, 190, 194, 196, 223, 229
 - Initial spares purchas, 344
 - In-service asse, 26, 127, 187, 375
 - In service date, 78, 117, 136
 - In-service need, 178–180
 - In-service support, 25, 35, 41, 187, 188, 190
 - Inspection, 165, 169, 257, 304, 308, 312, 321, 417
 - Inspection effectiveness, 50, 307
 - Insurance spare, 269, 359, 360, 364
 - Integrated logistic support, 285, 291
 - Integrated project team, 31, 40
 - Interest rate, 94, 95, 100, 101, 106, 444, 454, 459, 460
 - Internal rate of return (IRR), 81, 102, 103, 216, 496
 - Introduction into service, 126, 139, 141, 285
 - Inventory
 - accounting for, 363
 - system, 190
 - Inventory management
 - aim of, 344
 - Investment criteria, 101, 280, 482
 - ISO 55000, 5, 10, 191, 506, 519
 - ISO 55001, 36, 191, 507, 518
 - ISO 55002, 46, 507
- J**
- Job
 - planning, 63, 67, 76, 322
 - priority, 54, 148, 194, 215, 312, 322, 326, 350, 499
 - scoping, 312, 321, 323, 329
- K**
- Kanban, 313, 349
 - Key asset, 80, 161, 162
 - Key performance indicator, 244, 497, 516, 523
 - Kit, 142, 205, 231
- L**
- Labour
 - estimate, 330
 - direct, 330, 331
 - indirect, 332
 - Layer of protection, 421
 - Layout, 136, 228, 240, 263, 318, 423
 - Lead time
 - activity, 70, 78, 79, 87
 - demand, 351, 354, 355, 359, 366, 367
 - Leadership, 48, 53, 54, 506, 509, 518, 520
 - Leasing, 26, 34, 100, 128, 184, 433, 487, 488, 494
 - Level of repair analysis, 35, 49, 285, 288, 289, 291, 299–301
 - Level of service, 35, 37, 66, 67, 80, 115, 144, 145, 169, 277, 278, 374
 - Liabilities, 3, 9, 10, 220, 262, 278
 - Life cycl, 7, 11, 17, 19–21, 32, 33, 81, 97, 131, 150, 155, 189, 192, 443, 452, 457, 458, 466
 - Life cycle asset management plan, 149, 151, 155, 157, 158, 192
 - Life cycle cost, 81, 98, 132, 152, 155, 189, 444, 449, 457, 458, 467
 - Life of type, 175, 182–184
 - Likelihood, 250, 251, 258, 265, 269, 270, 384
 - Linear asset, 471, 474, 475
 - Loader, 97–100, 119, 140, 166, 442, 443–448
 - Loan, 94, 99, 481, 488, 489, 492–495
 - Location, 14, 131, 162, 195, 221, 225, 227, 230, 233, 287, 290, 327, 328, 347, 354, 423, 449
 - Logistician, 49
 - Logistic support
 - plan, 83, 129, 133, 134, 136, 157, 188, 200, 292, 293
 - Logistic support analysis, 49, 131, 151, 285, 287, 298, 299, 301, 317
 - Lost opportunity cost, 243–244
- M**
- Maintainability, 79, 88, 130, 132, 145, 373, 375, 399, 400, 402–407, 466, 523
 - Maintenance
 - basic, 303, 306–308, 314, 315, 402
 - budget, 320, 326, 327, 338, 340, 490
 - budgeting, 326
 - effectiveness, 401
 - load, 97, 98, 272
 - manager, 50
 - non-heroic, 304
 - organization, 35
 - planner, 51, 167
 - regime, 151, 191, 403, 410
 - routine, 18, 118, 153, 224, 277, 301, 308, 320
 - scheduler, 51
 - service, 153
 - time constraint, 403, 405
 - workload, 188, 326, 327
 - work management, 320
 - Maintenance cost, 32, 72, 75, 90, 100, 152, 231, 436, 438, 441, 449, 477, 500

- Maintenance plan, 51, 170, 322, 349, 371, 500
- Maintenance policy review, 397, 398
- Man–power utilization, 231
- Materials handling system, 106, 108, 109
- Materials requirements planning, 348–350, 355
- Matrix activity, 43, 44
- Maturity status, 82, 133
- MAX, 352, 355, 363
- Mean Time Between Failure (MTBF), 374, 399
- Mean Time to Repair (MTTR), 399, 400, 403
- MIN, 352
- Minimum Acceptable Rate of Return (MARR), 93, 104, 107, 108, 482, 496
- Mobile plant, 228, 407
- Moving average, 304

- N**
- Needs analysis, 66, 69, 121
- Needs and wants, 241
- Net present value, 96, 102, 106, 108, 114, 155, 184, 443
- Nominal dollar, 483
- Non–core activity, 272
- Non–current asset, 8, 20

- O**
- Off–the–shelf, 62, 81, 86, 130
- Open tender, 81, 131
- Operating cost, 12, 75, 81, 90, 116, 150, 153, 155, 247, 438, 446, 465, 472, 494
- Operating expense, 9, 131, 274, 433, 438, 446
- Operation, 79, 140, 153, 154, 422
- Operational concept, 61, 79, 80, 84
- Operational loss, 231, 328
- Operational readiness, 140, 141
- OPEX, 9, 13, 26, 34, 47, 123, 192, 193, 197, 203, 208, 209, 446
- Options, 7, 12, 21, 32, 61, 63, 69, 73, 79, 84–86, 88–90, 99, 114, 115, 120, 121, 123, 124, 149, 150, 158, 240–246, 259, 278, 289, 299, 301, 438, 442, 449, 456, 459, 470, 475, 482
- Original equipment manufacturer (OEM), 191, 296
- Outsource
 - what not to 2, 273
- Outsourcing
 - audit, 279
 - benefit, 274
 - contract, 277
 - cost, 275
 - risk, 278
- Overall equipment effectiveness, 500
- Overhead, 9, 244, 332
- Owner/operator model, 273

- P**
- P–F interval, 390, 391
- Pacific Earth Moving Part 4 CMMS, 233, 234
- Pareto analysis, 231, 383
- Part
 - catalogue, 292
 - explosion, 18, 344, 346, 423
- Payback period, 102, 106, 108
- Peak load, 272, 32, 107, 168, 272
- Performance based, 277, 279
- Performance indicator
 - maintenance, 500
- Performance recording, 308, 516
- Performance specification, 80
- Performance standard, 80, 130, 277
- Permit, 323, 415, 425
- Personnel, 52, 322
- Planners checklist, 325
- Planning assumption, 115
- Planning balance sheet, 239
- Planning horizon, 44, 66, 173, 482
- Planning period, 84, 192, 211
- Planning portfolio, 73, 82, 125, 126
- Planning schedule, 176
- Policy, 38, 397
- Portfolio management, 137
- Pre–feasibility analysis, 32, 126, 127
- Pre–plan gap, 89, 179
- Present value, 95, 96, 102, 106, 108, 155, 444, 463
- Preventive maintenance optimization, 397
- Price break, 356
- Procurement, 50, 80, 129
- Production
 - loss, 22, 63, 165, 166, 396
 - recoverable, 118
- Profit, 22, 32, 33, 81, 104, 216, 278, 364, 433
- Profitability index, 102, 104, 482
- Profit and loss, 210, 364, 384, 433
- Progress monitoring, 135
- Project
 - comparison, 102, 482
 - financial measure, 102, 105
 - initiation, 61
 - major, 31, 41, 63
 - management, 128, 137
 - maturity, 82, 133
 - milestone, 129
 - minor, 64

monitoring, 135
 portfolio, 137
 ranking, 217
 report, 135, 137
 team, 31, 127
 Project manager, 49, 50, 123, 128, 225, 261
 Public private partnership, 281
 Purchase planning, 180, 182

R

RACI chart, 134, 518
 Railway system, 417, 498
 Real rate of interest, 484, 492, 493
 Real term, 483, 484
 Redundancy, 36, 142, 165, 269, 375, 401, 404, 410
 Regulation, 13, 17, 21, 22, 72, 143, 240, 253, 254, 425, 465, 490, 491, 522
 Regulatory issue, 63, 188, 202
 Reliability
 improvement, 77, 213
 management, 376, 519
 Reliability centered maintenance, 34, 132, 392, 397
 Reliability centered procurement, 129
 Reliability improvement, 213, 329, 376
 Remaining life, 70, 175, 184, 214, 438, 469
 Reorder level, 351, 353, 354, 356, 360, 369
 Reorder quantity, 348, 350, 352, 363, 369, 372
 Repair part, 34, 153, 358, 364
 Repair pool, 118, 158, 289, 297, 357, 396, 410
 Repair/replace, 30, 35, 47, 189, 288, 297, 329, 441, 470
 Replacement
 planning, 48, 83, 231, 413, 463, 464
 Replacement age, 205, 456, 469, 478
 Replacement analysis, 189, 202, 455, 466
 Requirements portfolio, 67, 73, 83, 126, 144
 Resale, 431, 436, 444, 452, 477, 486
 Reserved stock, 356
 Resource requirement, 282, 383, 403, 409
 Response, 45, 54, 62, 69, 73, 79, 86, 88, 91, 120
 Responsibility, 28, 31, 44, 48, 50, 52, 142, 148, 231, 269, 276, 279, 312, 322, 488, 492, 494, 522
 Retirement schedule, 70, 176, 182, 183
 Return on Investment (ROI), 42, 104, 124, 207, 496
 Returned store, 357
 Revenue, 79, 81, 90, 96, 98, 105, 115, 116, 119, 212

Risk
 administrative, 256
 analysis, 6, 35, 251, 103, 116, 189, 251, 257, 261, 473, 501
 financial, 116, 256
 management, 17, 32, 35, 46, 189, 251, 253, 270, 414, 506, 511, 522
 matrix, 258
 mitigating, 259
 performance, 256
 rating, 252, 257, 265, 270
 register, 252, 259, 265, 270
 retirement of, 261
 solution, 116, 137, 255, 269
 sovereign, 255, 269, 270, 280
 supplier, 256
 technical, 189, 194, 210, 260, 466, 471
 treatment, 252, 265, 269, 270
 Risk analysis, 6, 30, 35, 103, 116, 189, 251, 257, 269, 276, 469, 473, 501
 Risk Based Inspection (RBI), 251, 257, 262, 417, 424
 Risk–cost, 262, 464, 471
 Roles, 48, 50, 52, 55, 115, 127, 190, 348, 466
 Rolling review, 211
 Root Cause Analysis (RCA), 47, 167, 223, 320, 339, 377, 384, 423, 516
 Rotable, 153, 188, 231, 277, 288, 291, 294, 297, 343, 357, 364, 396, 410

S

Safe operation, 416, 419, 422
 Safety, 413, 416–425, 465, 476, 500, 506
 Safety critical equipment, 416, 417, 419–421, 424, 425
 Safety integrity level, 422, 424
 Safety stock, 349, 354, 359, 372
 SAMP, 6, 38, 49, 191, 197, 508, 510, 519, 520
 Scope creep, 137
 Scope of work, 80, 116, 335
 Service level, 26, 193, 203, 279, 287, 329, 360, 372, 410
 Service loss, 117, 120
 Shelf life, 288, 354, 356
 Shortage cost, 359, 360, 372
 Silo, 366
 Sinking fund, 487, 492, 494
 Siting, 423
 Slow moving item, 350, 358, 359, 372
 Sole source, 88, 142
 Source and application of funds, 211, 212
 Sovereign risk, 255, 269, 280

- Spare part, 49, 153, 174, 224, 231, 285, 289, 294, 296, 302, 322, 343, 344, 347, 350, 357, 364, 371, 374, 396, 410, 433
 - Spares utilization, 231
 - Specification, 35, 66, 80, 129, 132, 137, 145, 154, 161, 192, 200, 275, 293, 374, 416, 424
 - Spend limit, 36, 214, 465, 469, 470, 478, 480
 - Spider diagram
 - cost benefit, 242–246, 248, 362
 - Stakeholder, 31, 44, 47, 54, 67, 74, 76–78, 117, 121, 136, 140, 143, 145, 197, 203, 244, 251, 506, 520
 - Status quo, 78, 117
 - Stock control, 13, 231, 352, 354, 355, 368
 - Stock Keeping Unit (SKU), 346
 - Stock level, 188, 347, 350, 351, 355, 361, 368
 - Stock turns, 362
 - Storekeeper, 357
 - Stranded asset, 491
 - Strategic asset management plan, 6, 38, 39, 48, 191, 519
 - Strategy, 25, 38, 40, 81, 84, 90, 114, 144, 179, 193, 524
 - Supplier
 - evaluation of, 131
 - Preferred, 131, 174, 179
 - Supplier viewpoint, 285
 - Support services, 11, 153, 154, 188, 191, 194, 197, 203, 286, 297
 - Survey and quote, 277, 335
- T**
- Tag, 416, 419
 - Take 5, 253
 - Target level, 352, 498, 525
 - Tax, 435–438, 446, 460
 - Tax credit, 429, 435, 436, 447, 460
 - Technical authority, 50, 143, 191
 - Technical service, 191, 318
 - Test and evaluation, 83, 122, 131, 288
 - Through life support, 49, 77, 133, 293, 294
 - Time and material, 277
 - Today's dollar, 483, 484
 - Tool box meeting, 54
 - Top down, 62, 193, 203
 - Total productive maintenance, 304, 305
 - Training, 141, 306, 415
 - Trial, 34, 68, 375, 432
 - Truck, 32, 72, 101, 173, 499
- U**
- Un-augmented, 67, 70, 71, 83, 84, 178, 179
 - Un-augmented capability, 67, 70, 71, 83
 - User pays, 242
- V**
- Valuation, 79, 81, 114, 122, 131, 221, 231, 240, 246, 264, 284, 285, 286, 506, 516
 - Valuation method, 486
 - Value analysis, 242
 - Value engineering, 72, 242
 - Value for money, 73
 - Value index, 486, 487
 - Value turn, 362, 363, 410
 - Variable cost, 274, 469, 474, 481, 489, 490, 492, 494
- W**
- Water supply system, 209, 249, 263, 264, 265, 484, 498
 - Weighted average cost of capital (WACC), 481, 490, 492, 493
 - Wearout, 269, 377–379, 380, 381, 409
 - Wine selection, 120, 121
 - With and without analysis, 482
 - Written down value, 430, 431, 436, 439, 446, 482, 490
 - Write down, 40, 42, 364, 365
- Y**
- Year of decision, 87, 89, 175, 176, 182–184
 - Year of expiry, 87, 175, 176, 182, 183, 184