

Heat Transfer: Exercises

Chris Long; Naser Sayma



Download free books at

bookboon.com

Chris Long & Naser Sayma

Heat Transfer: Exercises

Heat Transfer: Exercises

© 2010 Chris Long, Naser Sayma & Ventus Publishing ApS

ISBN 978-87-7681-433-5

Contents

	Preface	5
1.	Introduction	6
2.	Conduction	11
3.	Convection	35
4.	Radiation	60
5.	Heat Exchangers	79

Please click the advert

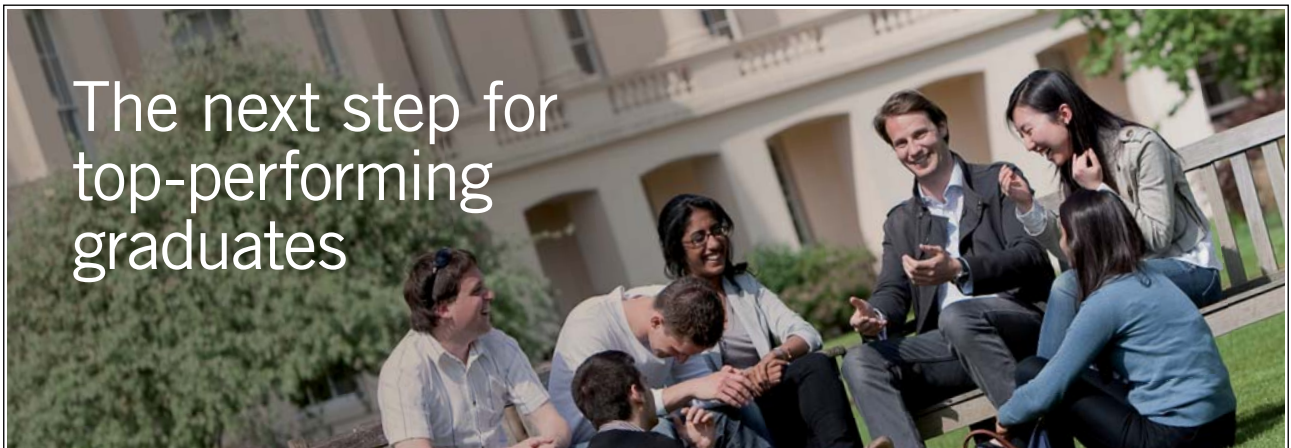

Masters in Management

Designed for high-achieving graduates across all disciplines, London Business School's Masters in Management provides specific and tangible foundations for a successful career in business.

This 12-month, full-time programme is a business qualification with impact. In 2010, our MiM employment rate was 95% within 3 months of graduation*; the majority of graduates choosing to work in consulting or financial services.

As well as a renowned qualification from a world-class business school, you also gain access to the School's network of more than 34,000 global alumni – a community that offers support and opportunities throughout your career.

For more information visit www.london.edu/mm, email mim@london.edu or give us a call on **+44 (0)20 7000 7573**.

* Figures taken from London Business School's Masters in Management 2010 employment report



Preface

Worked examples are a necessary element to any textbook in the sciences, because they reinforce the theory (i.e. the principles, concepts and methods). Once the theory has been understood, well chosen examples can be used, with modification, as a template to solve more complex, or similar problems.

This work book contains examples and full solutions to go with the text of our e-book (Heat Transfer, by Long and Sayma). The subject matter corresponds to the five chapters of our book: Introduction to Heat Transfer, Conduction, Convection, Heat Exchangers and Radiation. They have been carefully chosen with the above statement in mind. Whilst compiling these examples we were very much aware of the need to make them relevant to mechanical engineering students. Consequently many of the problems are taken from questions that have or may arise in a typical design process. The level of difficulty ranges from the very simple to challenging. Where appropriate, comments have been added which will hopefully allow the reader to occasionally learn something extra. We hope you benefit from following the solutions and would welcome your comments.

Christopher Long
Naser Sayma
Brighton, UK, February 2010

1. Introduction

Example 1.1

The wall of a house, 7 m wide and 6 m high is made from 0.3 m thick brick with $k = 0.6 \text{ W / m K}$. The surface temperature on the inside of the wall is 16°C and that on the outside is 6°C . Find the heat flux through the wall and the total heat loss through it.

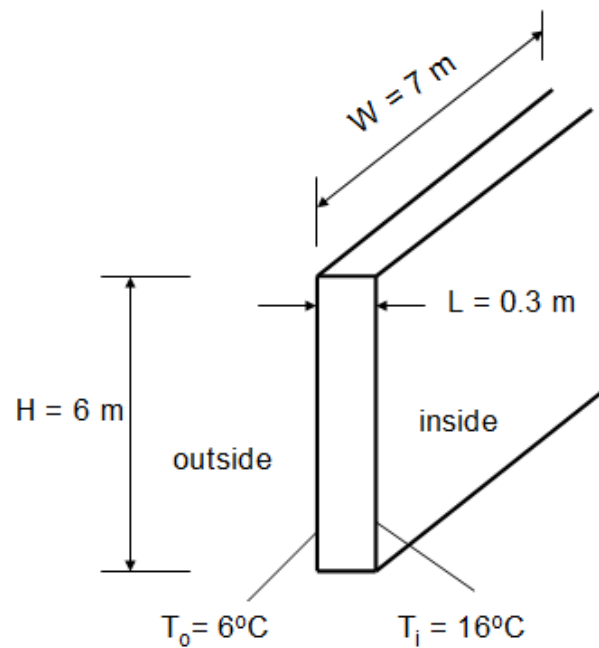

Solution:

For one-dimensional steady state conduction:

$$q = -k \frac{dT}{dx} = -\frac{k}{L}(T_i - T_o)$$

$$q = -\frac{0.6}{0.3}(16 - 6) = -20 \text{ W / m}^2$$

$$Q = qA = -20 \times (6 \times 7) = -840 \text{ W}$$

The minus sign indicates heat flux from inside to outside.

Example 1.2

A 20 mm diameter copper pipe is used to carry heated water, the external surface of the pipe is subjected to a convective heat transfer coefficient of $h = 6 \text{ W/m}^2\text{K}$, find the heat loss by convection per metre length of the pipe when the external surface temperature is 80°C and the surroundings are at 20°C . Assuming black body radiation what is the heat loss by radiation?

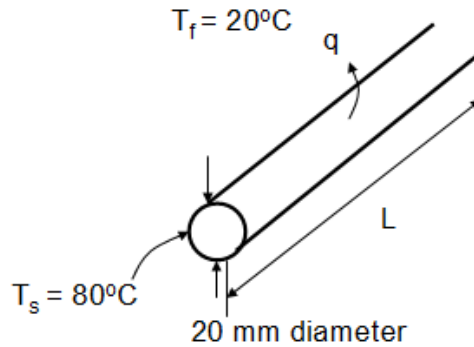
**Solution**

$$q_{conv} = h(T_s - T_f) = 6(80 - 20) = 360 \text{ W/m}^2$$

For 1 metre length of the pipe:

$$Q_{conv} = q_{conv} A = q_{conv} \times 2\pi r = 360 \times 2 \times \pi \times 0.01 = 22.6 \text{ W/m}$$

For radiation, assuming black body behaviour:

$$q_{rad} = \sigma(T_s^4 - T_f^4)$$

$$q_{rad} = 5.67 \times 10^{-8} (353^4 - 293^4)$$

$$q_{rad} = 462 \text{ W/m}^2$$

For 1 metre length of the pipe

$$Q_{rad} = q_{rad} A = 462 \times 2 \times \pi \times 0.01 = 29.1 \text{ W/m}^2$$

A value of $h = 6 \text{ W/m}^2\text{K}$ is representative of free convection from a tube of this diameter. The heat loss by (black-body) radiation is seen to be comparable to that by convection.

Example 1.3

A plate 0.3 m long and 0.1 m wide, with a thickness of 12 mm is made from stainless steel ($k = 16 \text{ W/mK}$), the top surface is exposed to an airstream of temperature 20°C . In an experiment, the plate is heated by an electrical heater (also 0.3 m by 0.1 m) positioned on the underside of the plate and the temperature of the plate adjacent to the heater is maintained at 100°C . A voltmeter and ammeter are connected to the heater and these read 200 V and 0.25 A, respectively. Assuming that the plate is perfectly insulated on all sides except the top surface, what is the convective heat transfer coefficient?

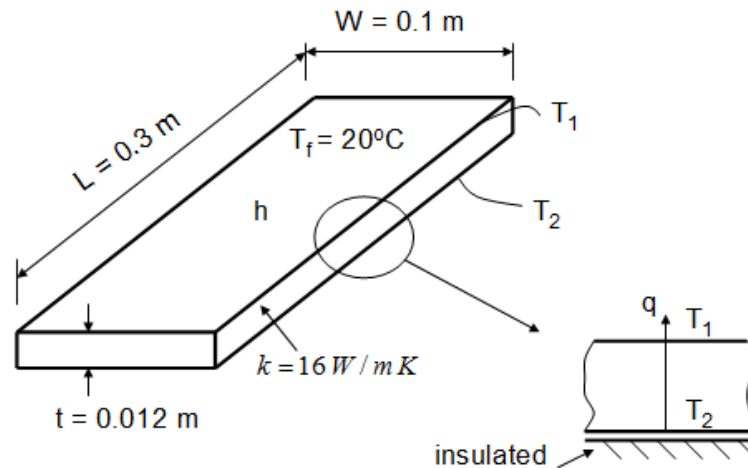
**Solution**

Heat flux equals power supplied to electric heater divided by the exposed surface area:

$$q = \frac{V \times I}{A} = \frac{V \times I}{W \times L} = \frac{200 \times 0.25}{0.1 \times 0.3} = 1666.7 \text{ W/m}^2$$

This will equal the conducted heat through the plate:

$$q = \frac{k}{t}(T_2 - T_1)$$

$$T_1 = T_2 - \frac{qt}{k} = 100 - \frac{(1666.7 \times 0.012)}{16} = 98.75^\circ\text{C} \quad (371.75 \text{ K})$$

The conducted heat will be transferred by convection and radiation at the surface:

$$q = h(T_1 - T_f) + \sigma(T_1^4 - T_f^4)$$

$$h = \frac{q - \sigma(T_1^4 - T_f^4)}{(T_1 - T_f)} = \frac{1666.7 - 5.67 \times 10^{-8}(371.75^4 - 293^4)}{371.75 - 293} = 12.7 \text{ W/m}^2\text{K}$$

Example 1.4

An electronic component dissipates 0.38 Watts through a heat sink by convection and radiation (black body) into surrounds at 20°C. What is the surface temperature of the heat sink if the convective heat transfer coefficient is 6 W/m² K, and the heat sink has an effective area of 0.001 m²?

Solution

$$q = \frac{Q}{A} = h(T_s - T_\infty) + \sigma(T_s^4 - T_\infty^4)$$

$$\frac{0.38}{0.001} = 6(T_s - 293) + 5.67 \times 10^{-8}(T_s^4 - 293^4)$$

$$5.67 \times 10^{-8} T_s^4 + 6T_s - 2555.9 = 0$$

This equation needs to be solved numerically. Newton-Raphson's method will be used here:

$$f = 5.67 \times 10^{-8} T_s^4 + 6T_s - 2555.9$$

$$\frac{df}{dT_s} = 22.68 \times 10^{-8} T_s^3 + 6$$

$$T_s^{n+1} = T_s^n - \frac{f}{\left(\frac{df}{dT_s}\right)} = T_s^n - \frac{5.67 \times 10^{-8} T_s^4 + 6T_s - 2555.9}{22.68 T_s^3 + 6}$$

Start iterations with $T_s^0 = 300 \text{ K}$

$$T_s^1 = 300 - \frac{5.67 \times 10^{-8} \times 300^4 + 6 \times 300 - 2555.9}{22.68 \times 300^3 + 6} = 324.46 \text{ K}$$

$$T_s^2 = 324.46 - \frac{5.67 \times 10^{-8} \times 324.46^4 + 6 \times 324.46 - 2555.9}{22.68 \times 324.46^3 + 6} = 323 \text{ K}$$

The difference between the last two iterations is small, so:

$$T_s^0 = 323 \text{ K} = 50^\circ\text{C}$$

The value of 300 K as a temperature to begin the iteration has no particular significance other than being above the ambient temperature.

Please click the advert



Excellent Economics and Business programmes at:



university of
 groningen



“The perfect start
 of a successful,
 international career.”

CLICK HERE
 to discover why both socially
 and academically the University
 of Groningen is one of the best
 places for a student to be

www.rug.nl/feb/education

Download free ebooks at bookboon.com

2. Conduction

Example 2.1

Using an appropriate control volume show that the time dependent conduction equation in cylindrical coordinates for a material with constant thermal conductivity, density and specific heat is given by:

$$\frac{\partial^2 T}{\partial r^2} + \frac{1}{r} \frac{\partial T}{\partial r} + \frac{\partial^2 T}{\partial z^2} = \frac{1}{\alpha} \frac{\partial T}{\partial t}$$

Where $\alpha = \frac{k}{\rho c}$ is the thermal diffusivity.

Solution

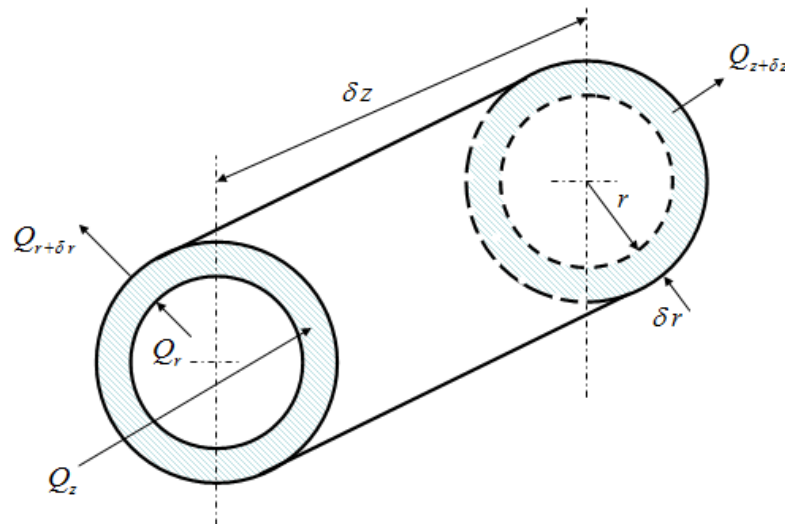

Consider a heat balance on an annular control volume as shown the figure above. The heat balance in the control volume is given by:

Heat in + Heat out = rate of change of internal energy

$$Q_r + Q_z - Q_{r+\delta r} - Q_{z+\delta z} = \frac{\partial u}{\partial t} \quad (2.1)$$

$$Q_{r+\delta r} = Q_r + \frac{\partial Q}{\partial r} \delta r$$

$$Q_{z+\delta z} = Q_z + \frac{\partial Q}{\partial z} \delta z$$

$$u = mcT$$

Substituting in equation 2.1:

$$-\frac{\partial Q}{\partial r} \delta r - \frac{\partial Q}{\partial z} \delta z = \frac{\partial(mcT)}{\partial t} \quad (2.2)$$

Fourier's law in the normal direction of the outward normal n:

$$\frac{Q}{A} = -k \frac{\partial T}{\partial n}$$

$$Q_r = -kA \frac{\partial T}{\partial r} = -k \times 2\pi r \delta z \frac{\partial T}{\partial r} \quad (A = 2\pi r \delta z)$$

$$Q_z = -kA \frac{\partial T}{\partial z} = -k \times 2\pi r \delta r \frac{\partial T}{\partial z} \quad (A = 2\pi r \delta r)$$

Equation 2.1 becomes

$$-\frac{\partial}{\partial r} \left\{ -k \times 2\pi r \delta z \frac{\partial T}{\partial r} \right\} \delta r - \frac{\partial}{\partial z} \left\{ -k \times 2\pi r \delta r \frac{\partial T}{\partial z} \right\} \delta z = mc \frac{\partial T}{\partial t} \quad (2.3)$$

Noting that the mass of the control volume is given by:

$$m = \rho 2\pi r \delta r \delta z \quad \text{Equation 2.3 becomes}$$

$$\frac{\partial}{\partial r} \left\{ k r \frac{\partial T}{\partial r} \right\} \delta r + \frac{\partial}{\partial z} \left\{ k r \frac{\partial T}{\partial z} \right\} \delta z = \rho c r \frac{\partial T}{\partial t}$$

Dividing by r, noting that r can be taken outside the brackets in the second term because it is not a function of z. Also dividing by k since the thermal conductivity is constant:

$$\frac{1}{r} \frac{\partial}{\partial r} \left\{ r \frac{\partial T}{\partial r} \right\} + \frac{\partial^2 T}{\partial z^2} = \frac{\rho c}{k} \frac{\partial T}{\partial t}$$

Using the definition of the thermal diffusivity: $\alpha = \frac{k}{\rho c}$ and expanding the first term using the product rule:

$$\frac{1}{r} \frac{\partial}{\partial r} \left\{ r \frac{\partial^2 T}{\partial r^2} + \frac{\partial T}{\partial r} \frac{\partial r}{\partial r} \right\} + \frac{\partial^2 T}{\partial z^2} = \frac{1}{\alpha} \frac{\partial T}{\partial t} \quad \text{which gives the required outcome:}$$

$$\frac{\partial^2 T}{\partial r^2} + \frac{1}{r} \frac{\partial T}{\partial r} + \frac{\partial^2 T}{\partial z^2} = \frac{1}{\alpha} \frac{\partial T}{\partial t}$$

Example 2.2

An industrial freezer is designed to operate with an internal air temperature of -20°C when the external air temperature is 25°C and the internal and external heat transfer coefficients are $12 \text{ W/m}^2 \text{ K}$ and $8 \text{ W/m}^2 \text{ K}$, respectively. The walls of the freezer are composite construction, comprising of an inner layer of plastic ($k = 1 \text{ W/m K}$, and thickness of 3 mm), and an outer layer of stainless steel ($k = 16 \text{ W/m K}$, and thickness of 1 mm). Sandwiched between these two layers is a layer of insulation material with $k = 0.07 \text{ W/m K}$. Find the width of the insulation that is required to reduce the convective heat loss to 15 W/m^2 .

Please click the advert

Teach with the Best. Learn with the Best.

Agilent offers a wide variety of affordable, industry-leading electronic test equipment as well as knowledge-rich, on-line resources—for professors and students.

We have 100's of comprehensive web-based teaching tools, lab experiments, application notes, brochures, DVDs/CDs, posters, and more.



See what Agilent can do for you.
www.agilent.com/find/EDUstudents
www.agilent.com/find/EDUeducators

© Agilent Technologies, Inc. 2012

u.s. 1-800-829-4444 canada: 1-877-894-4414

Anticipate — Accelerate — Achieve

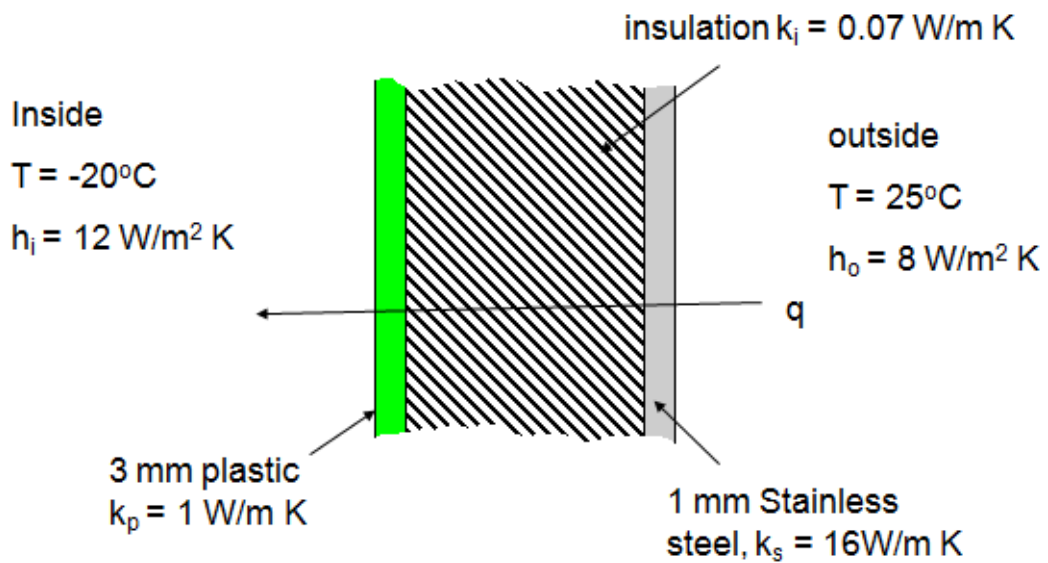

Agilent Technologies

**Solution**

$q = U\Delta T$ where U is the overall heat transfer coefficient given by:

$$U = \frac{q}{\Delta T} = \frac{15}{25 - (-20)} = 0.333 \text{ W/m}^2 \text{ K}$$

$$U = \left[\frac{1}{h_i} + \frac{L_p}{k_p} + \frac{L_i}{k_i} + \frac{L_s}{k_s} + \frac{1}{h_o} \right]^{-1} = 0.333$$

$$\left[\frac{1}{h_i} + \frac{L_p}{k_p} + \frac{L_i}{k_i} + \frac{L_s}{k_s} + \frac{1}{h_o} \right] = \frac{1}{0.333}$$

$$L_i = k_i \left\{ \frac{1}{0.333} - \left[\frac{1}{h_i} + \frac{L_p}{k_p} + \frac{L_s}{k_s} + \frac{1}{h_o} \right] \right\} = 0.07 \left\{ \frac{1}{0.333} - \left[\frac{1}{12} + \frac{0.003}{1} + \frac{0.001}{16} + \frac{1}{8} \right] \right\}$$

$$L_i = 0.195 \text{ m} \quad (195 \text{ mm})$$

Example 2.3

Water flows through a cast steel pipe ($k = 50 \text{ W/m K}$) with an outer diameter of 104 mm and 2 mm wall thickness.

- i. Calculate the heat loss by convection and conduction per metre length of uninsulated pipe when the water temperature is 15°C , the outside air temperature is -10°C , the water side heat transfer coefficient is $30 \text{ kW/m}^2 \text{ K}$ and the outside heat transfer coefficient is $20 \text{ W/m}^2 \text{ K}$.
- ii. Calculate the corresponding heat loss when the pipe is lagged with insulation having an outer diameter of 300 mm , and thermal conductivity of $k = 0.05 \text{ W/m K}$.

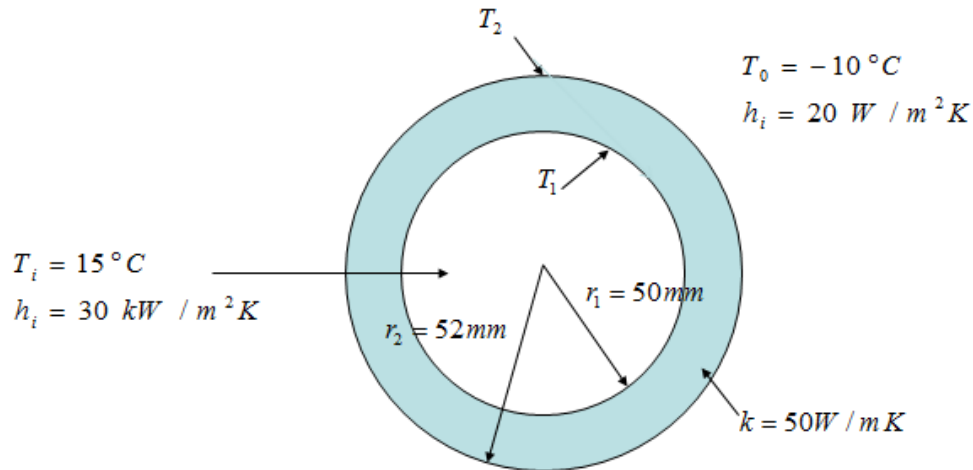
Solution

Plain pipe

$$Q = 2\pi r_1 L h_i (T_i - T_1) \quad \rightarrow \quad T_i - T_1 = \frac{Q}{2\pi r_1 L h_i}$$

$$Q = \frac{2\pi L k (T_1 - T_2)}{\ln(r_2 / r_1)} \quad \rightarrow \quad T_2 - T_1 = \frac{Q}{2\pi L k / \ln(r_2 / r_1)}$$

$$Q = 2\pi r_2 L h_o (T_2 - T_o) \quad \rightarrow \quad T_2 - T_o = \frac{Q}{2\pi r_2 L h_o}$$

Adding the three equations on the right column which eliminates the wall temperatures gives:

$$Q = \frac{2\pi L (T_i - T_o)}{\frac{1}{h_i r_1} + \frac{\ln(r_2 / r_1)}{k} + \frac{1}{h_o r_2}}$$

$$\frac{Q}{L} = \frac{2\pi(15 - (-10))}{\frac{1}{30000 \times 0.05} + \frac{\ln(0.052/0.05)}{50} + \frac{1}{20 \times 0.052}} = 163.3 \text{ W/m}$$

Insulated pipe

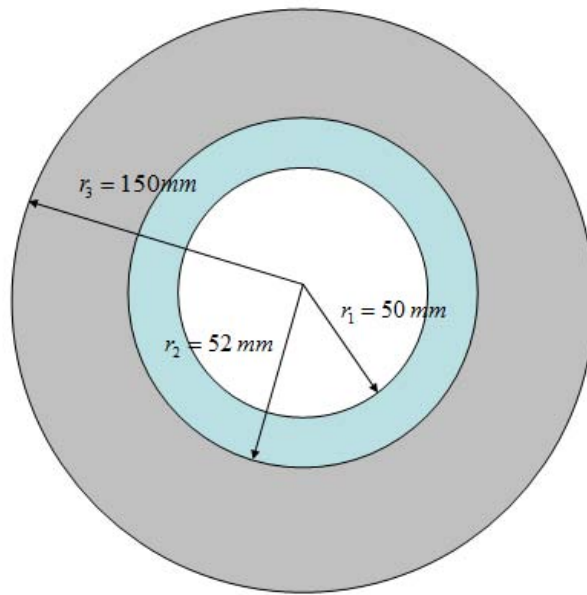

$$\frac{Q}{L} = \frac{2\pi(T_i - T_o)}{\frac{1}{h_i r_1} + \frac{\ln(r_2/r_1)}{k} + \frac{\ln(r_3/r_2)}{k_{ins}} + \frac{1}{h_o r_3}}$$

Please click the advert

Need help with your dissertation?

Get in-depth feedback & advice from experts in your topic area. Find out what you can do to improve the quality of your dissertation!

Get Help Now



Go to www.helpmyassignment.co.uk for more info



Download free ebooks at bookboon.com

$$\frac{Q}{L} = \frac{2\pi(15 - (-10))}{\frac{1}{30000 \times 0.05} + \frac{\ln(0.052/0.05)}{50} + \frac{\ln(0.15/0.052)}{0.05} + \frac{1}{20 \times 0.15}} = 7.3 \text{ W/m}$$

For the plain pipe, the heat loss is governed by the convective heat transfer coefficient on the outside, which provides the highest thermal resistance. For the insulated pipe, the insulation provides the higher thermal resistance and this layer governs the overall heat loss.

Example 2.4

Water at 80°C is pumped through 100 m of stainless steel pipe, $k = 16 \text{ W/m K}$ of inner and outer radii 47 mm and 50 mm respectively. The heat transfer coefficient due to water is 2000 $\text{W/m}^2 \text{ K}$. The outer surface of the pipe loses heat by convection to air at 20°C and the heat transfer coefficient is 200 $\text{W/m}^2 \text{ K}$. Calculate the heat flow through the pipe. Also calculate the heat flow through the pipe when a layer of insulation, $k = 0.1 \text{ W/m K}$ and 50 mm radial thickness is wrapped around the pipe.

Solution

The equation for heat flow through a pipe per unit length was developed in Example 2.3:

$$Q = \frac{2\pi L(T_i - T_o)}{\frac{1}{h_i r_1} + \frac{\ln(r_2/r_1)}{k} + \frac{1}{h_o r_2}}$$

Hence substituting into this equation:

$$Q = \frac{2\pi \times 100(80 - 20)}{\frac{1}{0.047 \times 2000} + \frac{\ln(50/47)}{16} + \frac{1}{0.05 \times 200}} = 0.329 \times 10^6 \text{ W}$$

For the case with insulation, we also use the equation from Example 2.3

$$Q = \frac{2\pi L(T_i - T_o)}{\frac{1}{h_i r_1} + \frac{\ln(r_2/r_1)}{k} + \frac{\ln(r_3/r_2)}{k_{ins}} + \frac{1}{h_o r_3}}$$

$$Q = \frac{2\pi \times 100(80 - 20)}{\frac{1}{0.047 \times 2000} + \frac{\ln(50/47)}{16} + \frac{\ln(100/50)}{0.1} + \frac{1}{0.1 \times 200}} = 5.39 \times 10^3 \text{ W}$$

Notice that with insulation, the thermal resistance of the insulator dominates the heat flow, so in the equation above, if we retain the thermal resistance for the insulation and ignore all the other terms, we obtain:

$$Q = \frac{2\pi L(T_i - T_o)}{\frac{\ln(r_3/r_2)}{k_{ins}}} = \frac{2\pi \times 100(80 - 20)}{\frac{\ln(100/50)}{0.1}} = 5.44 \times 10^3 W$$

This has less than 1% error compared with the full thermal resistance.

Example 2.5

A diagram of a heat sink to be used in an electronic application is shown below. There are a total of 9 aluminium fins ($k = 175 \text{ W/m K}$, $C = 900 \text{ J/kg K}$, $\rho = 2700 \text{ kg/m}^3$) of rectangular cross-section, each 60 mm long, 40 mm wide and 1 mm thick. The spacing between adjacent fins, s , is 3 mm. The temperature of the base of the heat sink has a maximum design value of $T_b = 60^\circ\text{C}$, when the external air temperature T_f is 20°C . Under these conditions, the external heat transfer coefficient h is $12 \text{ W/m}^2 \text{ K}$. The fin may be assumed to be sufficiently thin so that the heat transfer from the tip can be neglected. The surface temperature T , at a distance, x , from the base of the fin is given by:

$$T - T_f = \frac{(T_b - T_f) \cosh m(L - x)}{\sinh mL} \quad \text{where } m^2 = \frac{hP}{kA_c} \text{ and } A_c \text{ is the cross sectional area.}$$

Determine the total convective heat transfer from the heat sink, the fin effectiveness and the fin efficiency.

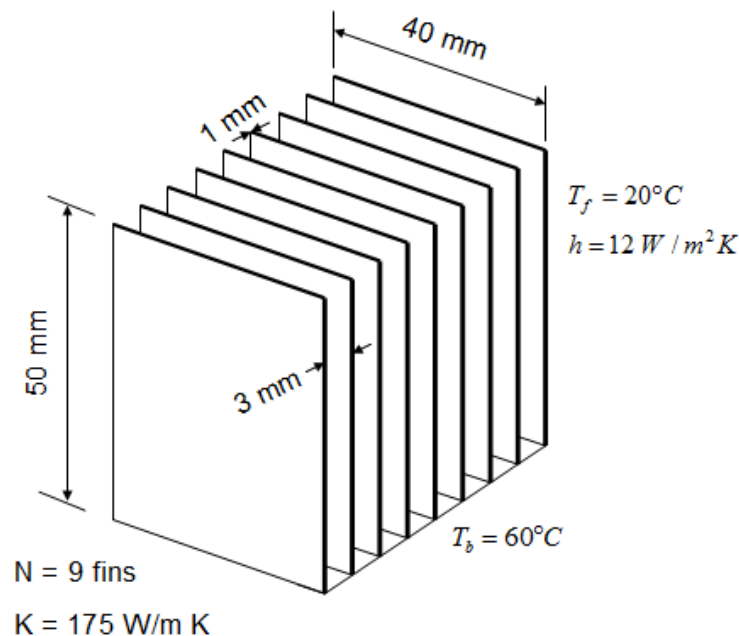

Solution

Total heat fluxed is that from the un-finned surface plus the heat flux from the fins.

$$Q = Q_u + Q_f$$

$$Q_u = A_u h (T_b - T_f) = w \times s (N - 1) h (T_b - T_f)$$

$$Q_u = 0.04 \times 0.003 (9 - 1) \times 12 (60 - 20) = 0.461 \text{ W}$$

For a single fin:

$$Q_f = -k A_c \left(\frac{dT}{dx} \right)_{x=0}$$

Where A_c is the cross sectional area of each fin

Since

$$T - T_f = \frac{(T_b - T_f) \cosh m(L - x)}{\sinh mL}$$

Please click the advert

Free online Magazines



Click here to download 
SpeakMagazines.com

Then

$$\frac{dT}{dx} = \frac{-\sinh m(L-x)}{\cosh mL} m (T_b - T_f)$$

Thus

$$Q_f = -kA_c \left(\frac{dT}{dx} \right)_{x=0} = -kA_c \left(\frac{-\sinh mL}{\cosh mL} \right) m (T_b - T_f)$$

$$Q_f = kA_c m (T_b - T_f) \tanh(mL) = (hp k A_c)^{1/2} (T_b - T_f) \tanh(mL)$$

Since

$$m = \left(\frac{hP}{kA_c} \right)^{1/2}$$

$$P = 2(w + t) = 2(0.04 + 0.001) = 0.082 \text{ m}$$

$$A_c = w \times t = 0.04 \times 0.0001 = 40 \times 10^{-6} \text{ m}^2$$

$$m = \left(\frac{12 \times 0.082}{175 \times 40 \times 10^{-6}} \right)^{1/2} = 11.856 \text{ m}^{-1}$$

$$mL = 11.856 \times 0.06 = 0.7113$$

$$\tanh(mL) = \tanh(0.7113) = 0.6115$$

$$Q_f = (12 \times 0.082 \times 175 \times 40 \times 10^{-6})^{1/2} \times (60 - 20) \times 0.6115 = 2.03 \text{ W / fin}$$

So total heat flow:

$$Q = Q_u + Q_f = 0.461 + 9 \times 2.03 = 18.7 \text{ W}$$

Fin effectiveness

$$\varepsilon_{fin} = \frac{\text{Fin heat transfer rate}}{\text{Heat transfer rate that would occur in the absence of the fin}} = \frac{Q_f}{hA_c (T_b - T_f)}$$

$$\varepsilon_{fin} = \frac{2.03}{12 \times 40 \times 10^{-6} (60 - 20)} = 106$$

Fin efficiency:

$$\eta_{fin} = \frac{\text{Actual heat transfer through the fin}}{\text{Heat that would be transferred if all the fin area were at the base temperature}}$$

$$\eta_{fin} = \frac{Q_f}{hA_s(T_b - T_f)}$$

$$A_s = wL + wL + Lt + Lt = 2L(w + t)$$

$$A_s = 2 \times 0.06(0.04 + 0.001) = 4.92 \times 10^{-3} \text{ m}^2$$

$$\eta_{fin} = \frac{2.03}{12 \times 4.92 \times 10^{-3} (60 - 20)} = 0.86$$

Example 2.6

For the fin of example 4.5, a fan was used to improve the thermal performance, and as a result, the heat transfer coefficient is increased to 40 W/m² K. Justify the use of the lumped mass approximation to predict the rate of change of temperature with time. Using the lumped mass approximation given below, calculate the time taken, τ , for the heat sink to cool from 60°C to 30°C.

$$(T - T_f) = (T_i - T_f) \exp\left(-\frac{hA_s \tau}{mC}\right)$$

Solution

Consider a single fin (the length scale L for the Biot number is half the thickness $t/2$)

$$B_i = \frac{hL}{k} = \frac{h \times t / 2}{k} = \frac{40 \times 0.0005}{175} \approx 10^{-4}$$

Since $B_i \ll 1$, we can use the “lumped mass” model approximation.

$$\frac{(T - T_f)}{(T_i - T_f)} = \exp\left(-\frac{hA_s \tau}{mC}\right)$$

$$\tau = -\frac{mC}{hA_s} \ln\left(\frac{T - T_f}{T_i - T_f}\right)$$

$$m = \rho A_s t / 2$$

$$\tau = -\frac{\rho C t}{2h} \ln\left(\frac{T - T_f}{T_i - T_f}\right) = -\frac{2700 \times 900 \times 0.001}{2 \times 40} \ln\left(\frac{30 - 20}{60 - 20}\right) = 42 \text{ seconds}$$

Example 2.7

The figure below shows part of a set of radial aluminium fins ($k = 180 \text{ W/m K}$) that are to be fitted to a small air compressor. The device dissipates 1 kW by convecting to the surrounding air which is at 20°C . Each fin is 100 mm long, 30 mm high and 5 mm thick. The tip of each fin may be assumed to be adiabatic and a heat transfer coefficient of $h = 15 \text{ W/m}^2 \text{ K}$ acts over the remaining surfaces.

Estimate the number of fins required to ensure the base temperature does not exceed 120°C

Please click the advert



You're full of *energy*
and *ideas*. And that's
just what we are looking for.

Looking for a career where your ideas could really make a difference? UBS's Graduate Programme and internships are a chance for you to experience for yourself what it's like to be part of a global team that rewards your input and believes in succeeding together.

Wherever you are in your academic career, make your future a part of ours by visiting www.ubs.com/graduates.

www.ubs.com/graduates



© UBS 2010. All rights reserved.

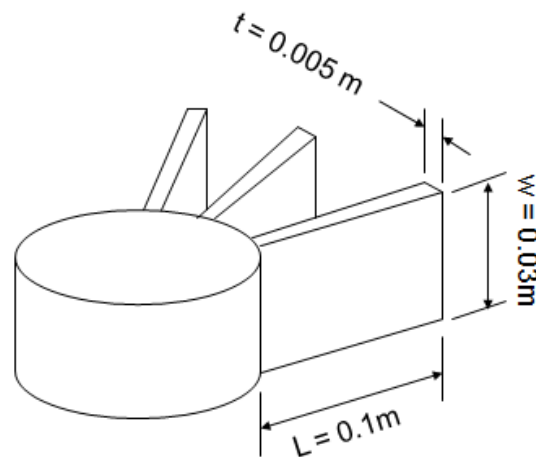

Solution

Consider a single fin:

$$P = 2(w + t) = 2(0.005 + 0.03) = 0.07\text{ m}$$

$$A_c = w \times t = 0.005 \times 0.03 = 150 \times 10^{-6}\text{ m}^2$$

$$m = \left(\frac{hP}{kA_c} \right)^{\frac{1}{2}} = \left(\frac{15 \times 0.07}{180 \times 150 \times 10^{-6}} \right)^{\frac{1}{2}} = 6.2361\text{ m}^{-1}$$

$$mL = 6.2361 \times 0.1 = 0.62361$$

$$\tanh(mL) = 0.5536$$

$$Q_f = (hPkA_c)^{1/2} (T_b - T_f) \tanh(mL) \quad (\text{From example 2.5})$$

$$Q_f = (15 \times 0.07 \times 180 \times 150 \times 10^{-6})^{1/2} \times (120 - 20) \times 0.5536 = 9.32\text{ W}$$

So for 1 kW, the total number of fins required:

$$N = \frac{1000}{9.32} = 108$$

Example 2.8

An air temperature probe may be analysed as a fin. Calculate the temperature recorded by a probe of length $L = 20$ mm, $k = 19$ W/m K, $D = 3$ mm, when there is an external heat transfer coefficient of $h = 50$ W/m²K, an actual air temperature of 50°C and the surface temperature at the base of the probe is 60°C .

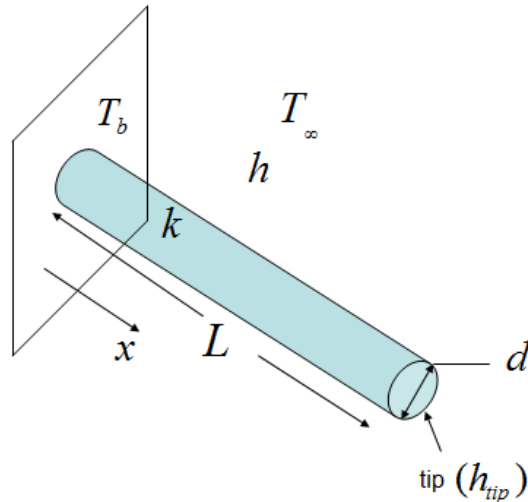
**Solution**

The error should be zero when $T_{tip} = T_\infty$. The temperature distribution along the length of the probe (from the full fin equation) is given by:

$$\frac{T_x - T_\infty}{T_b - T_\infty} = \frac{\cosh m(L-x) + \frac{h_{tip}}{mk} \sinh m(L-x)}{\cosh mL + \frac{h_{tip}}{mk} \sinh mL}$$

$$m = \left(\frac{hP}{kA} \right)^{1/2} \quad A = \pi D^2 / 4, \quad P = \pi D$$

At the tip, $x = L$, the temperature is given by ($\cosh(0) = 1$, $\sinh(0) = 0$):

$$\frac{T_{tip} - T_\infty}{T_b - T_\infty} = \frac{1}{\cosh mL + \frac{h_{tip}}{mk} \sinh mL} = \phi$$

Where ϕ is the dimensionless error:

$$\phi = 0, \quad T_{tip} = T_\infty \quad (\text{no error})$$

$$\phi = 1, \quad T_L = T_b \quad (\text{large error})$$

$$\text{For } L = 20\text{mm}, \quad k = 19\text{W/mK}, \quad D = 3\text{mm}, \quad h = h_{ip} = 50\text{W/m}^2\text{K}$$

$$T_\infty = 50^\circ\text{C}, \quad T_b = 60^\circ\text{C}$$

$$A = \pi D^2 / 4, \quad P = \pi D$$

$$m = \left(\frac{hP}{kA} \right)^{1/2} = \left(\frac{h\pi D \times 4}{k\pi D^2} \right)^{1/2} = \left(\frac{4h}{kD} \right)^{1/2} = \left(\frac{4 \times 50}{19 \times 0.003} \right)^{1/2} = 59.235\text{ m}^{-1}$$

$$mL = 59.235 \times 0.02 = 1.185$$

$$\frac{h}{mk} = \frac{50}{59.235 \times 19} = 0.0444$$

$$\frac{T_x - T_\infty}{T_b - T_\infty} = \frac{1}{\cosh(1.185) + 0.0444 \times \sinh(1.185)} = 0.539$$

Please click the advert



Discover the truth at www.deloitte.ca/careers

Deloitte.

© Deloitte & Touche LLP and affiliated entities.

$$T_{tip} = 0.539(T_b - T_\infty) + T_\infty$$

$$T_{tip} = 0.539(60 - 50) + 50 = 55.39^\circ\text{C}$$

Hence error = 5.39°C

Example 2.9

A design of an apartment block at a ski resort requires a balcony projecting from each of the 350 separate apartments. The walls of the building are 0.3 m wide and made from a material with $k = 1$ W/m K. Use the fin approximation to examine the implications on the heat transfer for two separate suggestions for this design. In each case, the balcony projects 2 m from the building and has a length (parallel to the wall) of 4 m. Assume an inside temperature of 20°C and an outside temperature of -5°C ; the overall (convective + radiative) heat transfer coefficient on the inside of the building is 8 W/m² K and on that on the outside of the building is 20 W/m² K

- A balcony constructed from solid concrete and built into the wall, 0.2 m thick, $k = 2$ W/m K.
- A balcony suspended from 3 steel beams, $k = 40$ W/m K, built into the wall and projecting out by 2 m each of effective cross sectional area $A_e = 0.01$ m², perimeter $P = 0.6$ m (The actual floor of the balcony in this case may be considered to be insulated from the wall)
- No balcony.

Solution

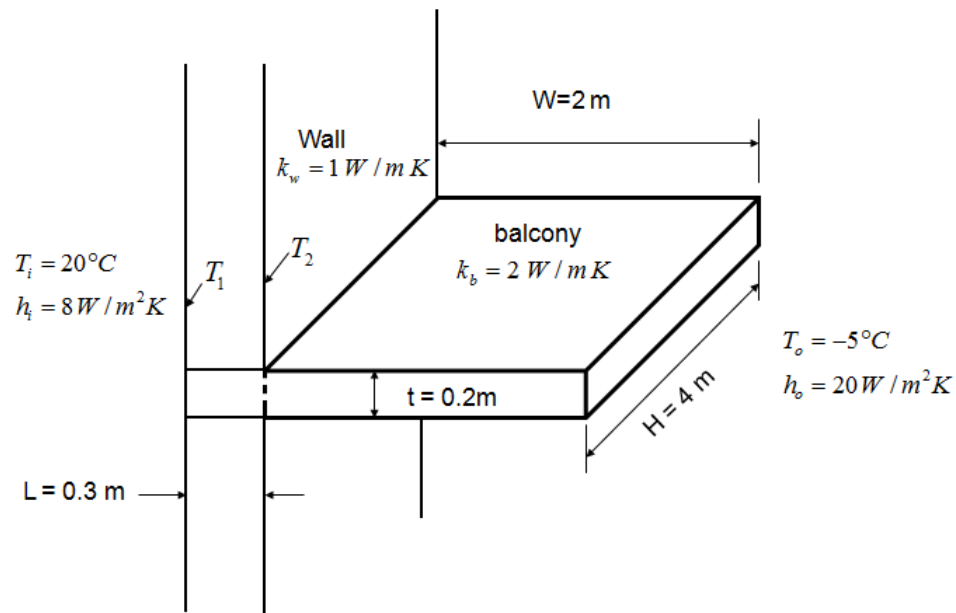

- For the concrete balcony

Treat the solid balcony as a fin $B_i = \frac{h_o t / 2}{k_b}$

$$Bi = \frac{20 \times 0.1}{2} = 1$$

Not that Bi is not $\ll 1$, thus 2D analysis would be more accurate. However, treating it as a fin will give an acceptable result for the purpose of a quick calculation.

$$P = 2(H + t) = 2(4 + 0.2) = 8.4 \text{ m}$$

$$A_c = H \times t = 4 \times 0.2 = 0.8 \text{ m}^2$$

To decide if the fin is infinite, we need to evaluate mL (which is in fact in the notation used here is mW)

$$mW = \left(\frac{hP}{kA} \right)^{1/2} W = \left(\frac{20 \times 8.4}{2 \times 0.8} \right)^{1/2} \times 2 = 20.5$$

This is large enough to justify the use of the fin infinite equation.

$$Q_b = (h_o P k_b A_c)^{1/2} (T_2 - T_o)$$

$$q_b = \frac{1}{A_c} (h_o P k_b A_c)^{1/2} (T_2 - T_o) = \left(\frac{h_o P k_b}{A_c} \right)^{1/2} (T_2 - T_o) \quad (1)$$

Also assuming 1-D conduction through the wall:

$$q_b = h_i (T_i - T_1) \quad (2)$$

$$q_b = \frac{k_b}{L} (T_1 - T_2) \quad (3)$$

Adding equations 1, 2 and 3 and rearranging:

$$q_b = \frac{(T_o - T_i)}{\frac{1}{h_i} + \frac{L}{k_b} + \left(\frac{A_c}{h_o P k_b} \right)^{1/2}} \quad (4)$$

This assumes 1D heat flow through the wall, the concrete balcony having a larger k than the wall may introduce some 2-D effects.

From (4)

$$q_b = \frac{20 - (-5)}{\frac{1}{8} + \frac{0.3}{2} + \left(\frac{0.8}{20 \times 8.4 \times 2}\right)^{1/2}} = 77.2 \text{ W/m}^2$$

Compared with no balcony:

$$q_b = \frac{(T_o - T_i)}{\frac{1}{h_i} + \frac{L}{k_w} + \frac{1}{h_o}} = \frac{20 - (-5)}{\frac{1}{8} + \frac{0.3}{1} + \frac{1}{20}} = 52.6 \text{ W/m}^2$$

The difference for one balcony is $A_c (77.2 - 52.6) = 0.8 \times 24.6 = 19.7 \text{ W}$

For 350 apartments, the difference is 6891 W .

For the steel supported balcony where $A_c = 0.01 \text{ m}^2$ and $P = 0.6 \text{ m}$

Please click the advert

Stafford
associates

Find your next education here!

Click here

bookboon.com/blog/subsites/stafford

As before, however, in this case $Bi \ll 1$ because $k_s \gg k_b$

$$mW = \left(\frac{hP}{kA}\right)^{1/2} w = \left(\frac{20 \times 6}{40 \times 0.1}\right)^{1/2} \times 2 \approx 11$$

$mW \gg 2$, so we can use the infinite fin approximation as before

$$q_b = \frac{(T_o - T_i)}{\frac{1}{h_i} + \frac{L}{k_s} + \left(\frac{A_c}{h_o P k_s}\right)^{1/2}} = \frac{20 - (-5)}{\frac{1}{8} + \frac{0.3}{40} + \left(\frac{0.01}{20 \times 6 \times 40}\right)^{1/2}} = 182 \text{ W/m}^2$$

$$Q_b = A_c q_b = 0.01 \times 182 = 1.82 \text{ W/beam}$$

For 350 apartments, $Q_b = 1915 \text{ W}$

Example 2.10

In free convection, the heat transfer coefficient varies with the surface to fluid temperature difference $(T_s - T_f)$. Using the low Biot number approximation and assuming this variation to be of the form

$h = G(T_s - T_f)^n$ Where G and n are constants, show that the variation of the dimensionless temperature ratio with time will be given by

$$\theta^{-n} = 1 + (nh_{init} \lambda) t$$

Where

$$\theta = \frac{(T_s - T_f)}{T_{init} - T_f}, \quad \lambda = \frac{\text{Area}}{\text{Mass} \times \text{Specific Heat Capacity}}$$

and h_{init} = the heat transfer coefficient at $t = 0$. Use this expression to determine the time taken for an aluminium motorcycle fin ($\rho = 2750 \text{ kg/m}^3$, $C = 870 \text{ J/kgK}$) of effective area 0.04 m^2 and thickness 2 mm to cool from 120°C to 40°C in surrounding air at 20°C when the initial external heat transfer coefficient due to laminar free convection is $16 \text{ W/m}^2 \text{ K}$. Compare this with the time estimated from the equation ($\theta = e^{-h\lambda t}$) which assumes a constant value of heat transfer coefficient.

Solution

Low Biot number approximation for free convection for $B_i \ll 1$

Heat transfer by convection = rate of change of internal energy

$$hA(T_s - T_f) = -mC \frac{d(T_s - T_f)}{dt} \quad (1)$$

We know that $h = G(T_s - T_f)^n$

Where G is a constant.

(Note that this relation arises from the usual Nusselt/Grashof relationship in free convection; for example: $Nu = 0.1(Gr Pr)^{1/3}$ in turbulent flow or $Nu = 0.54(Gr Pr)^{1/4}$ for laminar flow)

Equation 1 then becomes:

$$G(T_s - T_f)^n (T_s - T_f) = -\frac{mC}{A} \frac{d(T_s - T_f)}{dt}$$

$$\int_{t=0}^t \frac{-GA}{mC} dt = \int_{t=0}^t \frac{d(T_s - T_f)}{(T_s - T_f)^{n+1}}$$

$$\frac{GnAt}{mC} = (T_s - T_f)^{-n} - (T_s - T_f)_{t=0}^{-n} \quad (2)$$

$$\text{At } t = 0, \quad (T_s - T_f) = (T_{s,i} - T_f)$$

If we divide equation 2 by $(T_{s,i} - T_f)^{-n}$

$$\text{And use the definition } \theta = \frac{(T_s - T_f)}{(T_{s,i} - T_f)}$$

We obtain

$$\frac{GnAt}{mC(T_{s,i} - T_f)^{-n}} = \theta^{-n} - 1 = \frac{GnAt}{mC} (T_{s,i} - T_f)^n$$

Since $G(T_{s,i} - T_f) = h_i$, the heat transfer coefficient at time $t = 0$, then

$$\theta^{-n} = \frac{h_i At}{mC} + 1$$

Or $\theta^{-n} = nh_i \lambda t + 1$

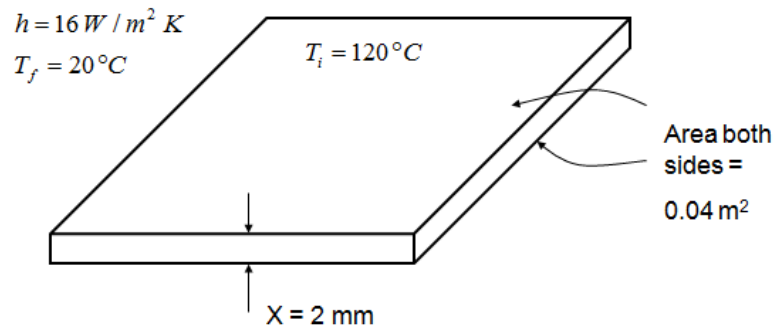

For aluminium $\rho = 2750 \text{ kg/m}^3$, $C = 870 \text{ J/kg K}$

For laminar free convection, $n = \frac{1}{4}$

$$m = \rho A X = 2750 \times 0.04 \times 0.002 = 0.22 \text{ kg}$$

$$\lambda = \frac{A}{mC} = \frac{0.04}{0.22 \times 870} = 2.1 \times 10^{-4} \text{ m}^2 \text{ K/J}$$

$\theta^{-n} = nh_i \lambda t + 1$ which gives

Please click the advert

It's only an opportunity if you act on it

IKEA.SE/STUDENT

© Inter IKEA Systems B.V. 2009

$$t = \frac{(\theta^{-n} - 1)}{nh_i \lambda}$$

$$\text{When } T = 40^\circ\text{C} \quad \theta = \frac{40 - 20}{120 - 20} = 0.2$$

Then

$$t = \frac{(0.2^{-1/4} - 1)}{(1/4) \times 16 \times 2.1 \times 10^{-4}} = 590 \text{ s}$$

$$\text{For the equation } \theta = e^{-h\lambda t}$$

which assumes that the heat transfer coefficient is independent of surface-to-fluid temperature difference.

$$t = \frac{\ln \theta}{-h\lambda} = \frac{\ln 0.2}{-16 \times 2.1 \times 10^{-4}} = 479 \text{ s}$$

$$\text{Percentage error} = \frac{590 - 479}{590} \times 100 = 19\%$$

Example 2.11

A 1 mm diameter spherical thermocouple bead ($C = 400 \text{ J/kg K}$, $\rho = 7800 \text{ kg m}^3$) is required to respond to 99.5% change of the surrounding air ($\rho = 1.2 \text{ kg m}^3$, $\mu = 1.8 \times 10^{-6} \text{ kg/m s}$, $k = 0.0262 \text{ W/m K}$ and $Pr = 0.77$) temperature in 10 ms. What is the minimum air speed at which this will occur?

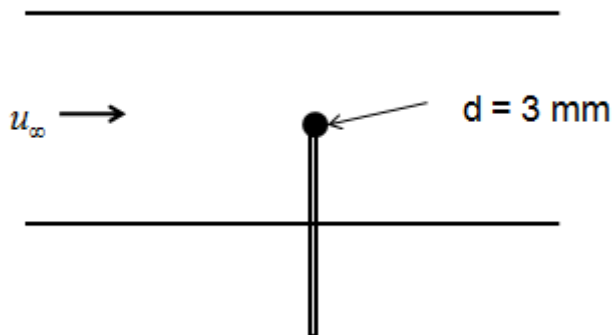

Solution

Spherical bead: $area = \pi d^2$

$$volume = \pi d^3/6$$

Assume this behaves as a lumped mass, then

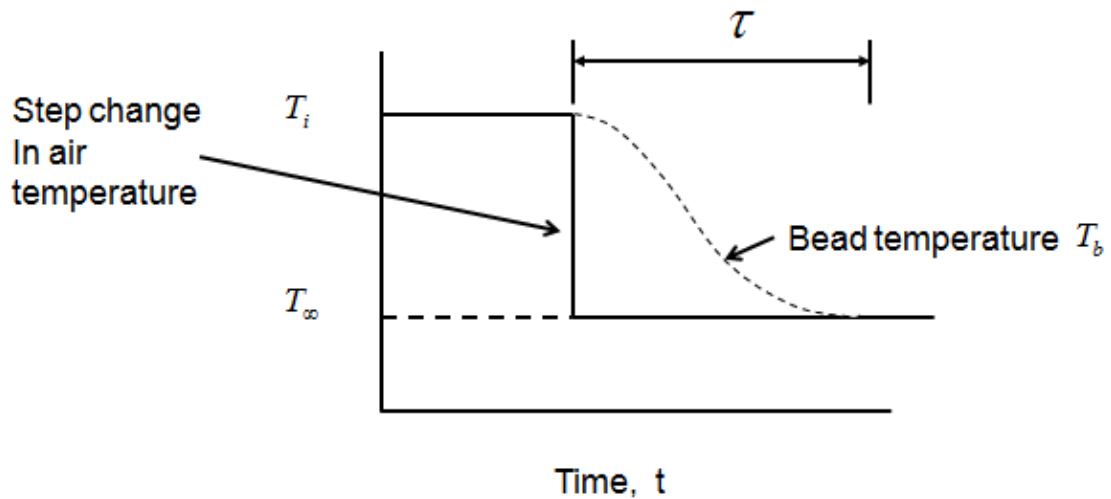

$$\frac{T_b - T_\infty}{T_\infty - T_i} = 0.995$$

(given)

For lumped mass on cooling from temperature T_i

$$\frac{T_b - T_\infty}{T_\infty - T_i} = \exp(-\lambda t) = 0.995$$

$$\lambda = \frac{hA}{mC}, \quad t = 0.01 \text{ s}$$

$$\lambda t = 0.005$$

$$\lambda = 0.5$$

Which gives the required value of heat transfer coefficient

$$\frac{hA}{\rho VC} = 0.5$$

So

$$h = 0.5 \frac{\pi d^3 C \rho}{6 \pi d^2} = \frac{0.5 d C \rho}{6}$$

$$h = \frac{0.5 \times 10^{-3} \times 400 \times 7800}{6} = 260 \text{ W/m}^2 \text{ K}$$

$$Nu_D = \frac{hD}{k} = \frac{260 \times 10^{-3}}{0.0262} = 9.9$$

For a sphere

$$Nu_D = 2 + \left\{ 0.4Re_D^{1/2} + 0.06Re_D^{2/3} \right\} Pr^{0.4}$$

From which with $Pr = 0.707$

$$f = 0.4Re_D^{1/2} + 0.06Re_D^{2/3} - 9.4 = 0$$

$$\dot{f} = 0.2Re_D^{-1/2} + 0.04Re_D^{-1/3}$$

Using Newton iteration

$$x^{(n+1)} = x^n - \frac{f(x)}{f'(x)}$$

Starting with $Re_D = 300$

$$Re_D^{(1)} = 300 - \frac{[0.4\sqrt{300} + 0.06(300)^{2/3} - 9.4]}{\left[\frac{0.2}{\sqrt{300}} + \frac{0.04}{300^{1/3}} \right]} = 300 - \frac{0.222}{0.01782}$$

Which is close enough to 300

From which

$$u_\infty = \frac{Re\mu}{D\rho} = 4.5 \text{ m/s}$$

3. Convection

Example 3.1

Calculate the Prandtl number ($Pr = \mu C_p / k$) for the following

- a) Water at 20°C: $\mu = 1.002 \times 10^{-3} \text{ kg/m s}$, $C_p = 4.183 \text{ kJ/kg K}$ and $k = 0.603 \text{ W/m K}$
 b) Water at 90°C: $\rho = 965 \text{ kg/m}^3$, $\nu = 3.22 \times 10^{-7} \text{ m}^2/\text{s}$, $C_p = 4208 \text{ J/kg K}$ and $k = 0.676 \text{ W/m K}$
 c) Air at 20°C and 1 bar: $R = 287 \text{ J/kg K}$, $\nu = 1.563 \times 10^{-5} \text{ m}^2/\text{s}$, $C_p = 1005 \text{ J/kg K}$ and $k = 0.02624 \text{ W/m K}$

d) Air at 100°C:
$$\mu = \frac{1.46 \times 10^{-6} T^{3/2}}{(110 + T)} \text{ kg/m s}$$

$C_p = 0.917 + 2.58 \times 10^{-4} T - 3.98 \times 10^{-8} T^2 \text{ kJ/kg K}$ (Where T is the absolute temperature in K) and $k = 0.03186 \text{ W/m K}$.

- e) Mercury at 20°C: $\mu = 1520 \times 10^{-6} \text{ kg/m s}$, $C_p = 0.139 \text{ kJ/kg K}$ and $k = 0.0081 \text{ kW/m K}$
 f) Liquid Sodium at 400 K: $\mu = 420 \times 10^{-6} \text{ kg/m s}$, $C_p = 1369 \text{ J/kg K}$ and $k = 86 \text{ W/m K}$
 g) Engine Oil at 60°C: $\mu = 8.36 \times 10^{-2} \text{ kg/m s}$, $C_p = 2035 \text{ J/kg K}$ and $k = 0.141 \text{ W/m K}$

Please click the advert

YOUR CHANCE
TO CHANGE
THE WORLD

Here at Ericsson we have a deep rooted belief that the innovations we make on a daily basis can have a profound effect on making the world a better place for people, business and society. Join us.

In Germany we are especially looking for graduates as Integration Engineers for

- Radio Access and IP Networks
- IMS and IPTV

We are looking forward to getting your application!
To apply and for all current job openings please visit our web page: www.ericsson.com/careers

ericsson.
com



Download free ebooks at bookboon.com

Solution

$$\text{a) } \text{Pr} = \frac{\mu C_p}{k} = \frac{1.002 \times 10^{-3} \times 4183}{0.603} = 6.95$$

$$\text{b) } \text{Pr} = \frac{\mu C_p}{k} = \frac{\rho \nu C_p}{k} = \frac{965 \times 3.22 \times 10^{-7} \times 4208}{0.676} = 1.93$$

$$\text{c) } \text{Pr} = \frac{\rho \nu C_p}{k}$$

$$\rho = \frac{P}{RT} = \frac{100000}{287 \times 293} = 1.19 \text{ kg/m}^3$$

$$\text{Pr} = \frac{1.19 \times 1.563 \times 10^{-5} \times 1005}{0.02624} = 0.712$$

$$\text{d) } \mu = \frac{1.46 \times 10^{-6} T^{3/2}}{(110 + T)} = \frac{1.46 \times 10^{-6} \times 373^{3/2}}{110 + 373} = 2.18 \times 10^{-5} \text{ kg/m s}$$

$$C_p = 0.917 + 2.58 \times 10^{-4} T - 3.98 \times 10^{-8} T^2 = 0.917 + 2.58 \times 10^{-4} \times 373 - 3.98 \times 10^{-8} \times 373^2 \\ = 1007.7 \text{ J/kg K}$$

$$\text{Pr} = \frac{2.18 \times 10^{-5} \times 1007.7}{0.03186} = 0.689$$

$$\text{e) } \text{Pr} = \frac{\mu C_p}{k} = \frac{1520 \times 10^{-6} \times 139}{0.0081 \times 10^3} = 0.0261$$

$$\text{f) } \text{Pr} = \frac{\mu C_p}{k} = \frac{420 \times 10^{-6} \times 1369}{86} = 0.0067$$

$$\text{g) } \text{Pr} = \frac{\mu C_p}{k} = \frac{8.36 \times 10^{-2} \times 2035}{0.141} = 1207$$

Comments:

- Large temperature dependence for water as in a) and b);
- small temperature dependence for air as in c) and d);
- use of Sutherland's law for viscosity as in part d);
- difference between liquid metal and oil as in e), f) and g);
- units of kW/m K for thermal conductivity;
- use of temperature dependence of c_p as in part a).

Example 3.2

Calculate the appropriate Reynolds numbers and state if the flow is laminar or turbulent for the following:

- A 10 m (water line length) long yacht sailing at 13 km/h in seawater $\rho = 1000 \text{ kg/m}^3$ and $\mu = 1.3 \times 10^{-3} \text{ kg/m s}$,
- A compressor disc of radius 0.3 m rotating at 15000 rev/min in air at 5 bar and 400°C and
$$\mu = \frac{1.46 \times 10^{-6} T^{3/2}}{(110 + T)} \text{ kg/m s}$$
- 0.05 kg/s of carbon dioxide gas at 400 K flowing in a 20 mm diameter pipe. For the viscosity take
$$\mu = \frac{1.56 \times 10^{-6} T^{3/2}}{(233 + T)} \text{ kg/m s}$$
- The roof of a coach 6 m long, travelling at 100 km/hr in air ($\rho = 1.2 \text{ kg/m}^3$ and $\mu = 1.8 \times 10^{-5} \text{ kg/m s}$)
- The flow of exhaust gas ($p = 1.1 \text{ bar}$, $T = 500^\circ\text{C}$, $R = 287 \text{ J/kg K}$ and $\mu = 3.56 \times 10^{-5} \text{ kg/m s}$) over a valve guide of diameter 10 mm in a 1.6 litre, four cylinder four stroke engine running at 3000 rev/min (assume 100% volumetric efficiency an inlet density of 1.2 kg/m^3 and an exhaust port diameter of 25 mm)

Solution

$$\text{a) } Re = \frac{\rho u L}{\mu} = \frac{10^3 \times \frac{13 \times 10^3}{3600} \times 10}{1.3 \times 10^{-3}} = 2.78 \times 10^7 \quad (\text{turbulent})$$

$$\text{b) } T = 400 + 273 = 673 \text{ K}$$

$$\mu = \frac{1.46 \times 10^{-6} \times 673^{3/2}}{(110 + 673)} = 3.26 \times 10^{-5} \text{ kg/m s}$$

$$\Omega = \frac{15000}{60} \times 2\pi = 1571 \text{ rad/s}$$

$$u = \Omega r = 1571 \times 0.3 = 471.3 \text{ m/s}$$

$$\rho = \frac{P}{RT} = \frac{100000}{287 \times 673} = 2.59 \text{ kg/m}^3$$

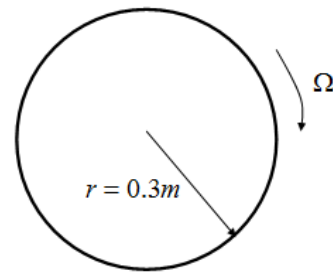

I joined MITAS because
I wanted **real responsibility**

The Graduate Programme
for Engineers and Geoscientists
Maersk.com/Mitas

Please click the advert



Month 16

I was a construction
supervisor in
the North Sea
advising and
helping foremen
solve problems

Real work
International opportunities
Three work placements



 **MAERSK**

Download free ebooks at bookboon.com

Characteristic length is r not D

$$\text{Re} = \frac{\rho u D}{\mu} = \frac{2.59 \times 471.3 \times 3}{3.26 \times 10^{-5}} = 1.12 \times 10^7 \quad (\text{turbulent})$$

$$\text{c) } \dot{m} = \rho u A = \rho u \times \frac{\pi D^2}{4}$$

$$u = \frac{4\dot{m}}{\rho \pi D^2}$$

$$\text{Re} = \frac{\rho u D}{\mu} = \frac{\rho \times 4\dot{m} D}{\rho \pi D^2 \mu} = \frac{4\dot{m}}{\pi D \mu}$$

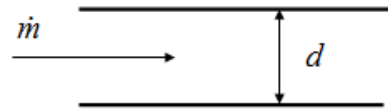

$$\mu = \frac{1.56 \times 10^{-6} \times 400^{3/2}}{(233 + 400)} = 1.97 \times 10^{-5} \text{ kg/m s}$$

$$\text{Re} = \frac{4 \times 0.05}{\pi \times 0.02 \times 1.97 \times 10^{-5}} = 1.6 \times 10^5 \quad (\text{turbulent})$$

$$\text{d) } u = \frac{100 \times 10^3}{3600} = 27.8 \text{ m/s}$$

$$\text{Re} = \frac{\rho u L}{\mu} = \frac{1.2 \times 27.8 \times 6}{1.8 \times 10^{-5}} = 11.1 \times 10^7 \quad (\text{turbulent})$$

e) Let \dot{m} be the mass flow through the exhaust port

\dot{m} = inlet density X volume of air used in each cylinder per second

$$\dot{m} = 1.2 \times \frac{1.6 \times 10^{-3}}{4} \times \frac{3600}{60} \times \frac{1}{2} = 0.012 \text{ kg/s}$$

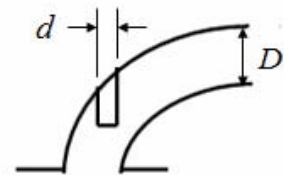

$$u = \frac{4\dot{m}}{\pi D^2 \rho}$$

$$\text{Re}_d = \frac{\rho u d}{\mu}$$

$$Re = \frac{4 \times 0.01 \times 0.012}{\pi \times 3.56 \times 10^{-5} \times 0.025} = 6869 \quad (\text{laminar})$$

Comments:

- Note the use of D to obtain the mass flow rate from continuity, but the use of d for the characteristic length
- Note the different criteria for transition from laminar flow (e.g. for a pipe $Re \approx 2300$ plate $Re \approx 3 \times 10^5$)

Example 3.3

Calculate the appropriate Grashof numbers and state if the flow is laminar or turbulent for the following:

- A central heating radiator, 0.6 m high with a surface temperature of 75°C in a room at 18°C ($\rho = 1.2 \text{ kg/m}^3$, $Pr = 0.72$ and $\mu = 1.8 \times 10^{-5} \text{ kg/m s}$)
- A horizontal oil sump, with a surface temperature of 40°C , 0.4 m long and 0.2 m wide containing oil at 75°C ($\rho = 854 \text{ kg/m}^3$, $Pr = 546$, $\beta = 0.7 \times 10^{-3} \text{ K}^{-1}$ and $\mu = 3.56 \times 10^{-2} \text{ kg/m s}$)
- The external surface of a heating coil, 30 mm diameter, having a surface temperature of 80°C in water at 20°C ($\rho = 1000 \text{ kg/m}^3$, $Pr = 6.95$, $\beta = 0.227 \times 10^{-3} \text{ K}^{-1}$ and $\mu = 1.00 \times 10^{-3} \text{ kg/m s}$)
- Air at 20°C ($\rho = 1.2 \text{ kg/m}^3$, $Pr = 0.72$ and $\mu = 1.8 \times 10^{-5} \text{ kg/m s}$) adjacent to a 60 mm diameter vertical, light bulb with a surface temperature of 90°C

Solution

$$a) \quad Gr = \frac{\rho^2 g \beta \Delta T L^3}{\mu^2}$$

$$\Delta T = 75 - 18 = 57 \text{ K}$$

$$\beta = \frac{1}{T} = \frac{1}{(18 + 273)} = \frac{1}{291} \text{ K}^{-1}$$

$$Gr = \frac{1.2^2 \times 9.81 \times 57 \times 0.6^3}{291 \times (1.8 \times 10^{-5})^2} = 1.84 \times 10^9$$

$$Gr Pr = 1.84 \times 10^9 \times 0.72 = 1.3 \times 10^9 \quad (\text{mostly laminar})$$

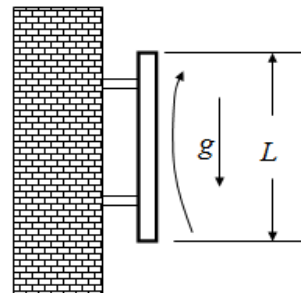

$$b) \quad L = \frac{\text{Area}}{\text{Perimeter}} = \frac{0.4 \times 0.2}{2 \times (0.4 + 0.2)} = 0.0667 \text{ m}$$

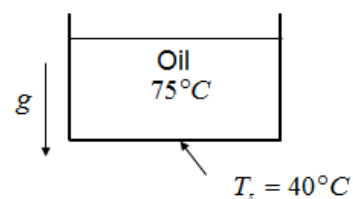

$$\Delta T = 75 - 40 = 35 \text{ K}$$

$$Gr = \frac{\rho^2 g \beta \Delta T L^3}{\mu^2} = \frac{854^2 \times 9.81 \times 0.7 \times 10^{-3} \times 35 \times 0.0667^3}{(3.56 \times 10^{-2})^2} = 4.1 \times 10^4$$

$$Gr Pr = 4.1 \times 10^4 \times 546 = 2.24 \times 10^7$$

Heated surface facing downward results in stable laminar flow for all $Gr Pr$

c)

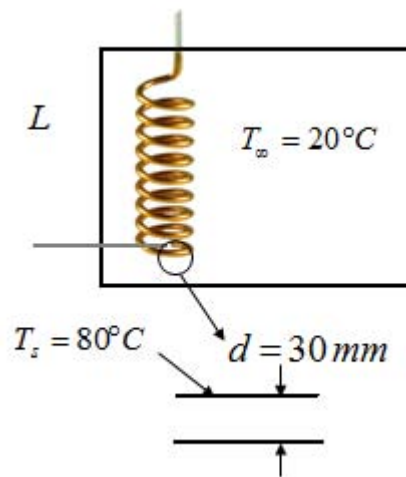

SIMPLY CLEVER

ŠKODA



We will turn your CV into an opportunity of a lifetime

Please click the advert



Do you like cars? Would you like to be a part of a successful brand? We will appreciate and reward both your enthusiasm and talent. Send us your CV. You will be surprised where it can take you.

Send us your CV on www.employerforlife.com



$$\Delta T = 80 - 20 = 60 \text{ K}$$

$$Gr = \frac{\rho^2 g \beta \Delta T L^3}{\mu^2} = \frac{1000^2 \times 9.81 \times 0.227 \times 10^{-3} \times 60 \times 0.03^3}{(1 \times 10^{-3})^2} = 3.6 \times 10^6$$

$$Gr Pr = 3.6 \times 10^6 \times 6.95 = 25 \times 10^6 \quad (\text{laminar})$$

$$d) \quad L = \frac{\text{Area}}{\text{Perimeter}} = \frac{\pi D^2}{4\pi D} = \frac{D}{4}$$

$$\Delta T = 90 - 20 = 70 \text{ K}$$

$$\beta = \frac{1}{T} = \frac{1}{(20 + 273)} = \frac{1}{293} \text{ K}^{-1}$$

$$Gr = \frac{\rho^2 g \beta \Delta T L^3}{\mu^2} = \frac{1.2^2 \times 9.8 \times 70 \times 0.015^3}{293 \times (1.8 \times 10^{-5})^2} = 3.5 \times 10^4$$

$$Gr Pr = 3.5 \times 10^4 \times 0.72 = 2.5 \times 10^4 \quad (\text{laminar})$$



Comments:

- Note evaluation of β for a gas is given by $\beta = 1/T$
- For a horizontal surface $L = A/p$

Example 3.4

Calculate the Nusselt numbers for the following:

- A flow of gas ($Pr = 0.71$, $\mu = 4.63 \times 10^{-5} \text{ kg/m s}$ and $C_p = 1175 \text{ J/kg K}$) over a turbine blade of chord length 20 mm, where the average heat transfer coefficient is $1000 \text{ W/m}^2 \text{ K}$.
- A horizontal electronics component with a surface temperature of 35°C , 5 mm wide and 10 mm long, dissipating 0.1 W by free convection from one side into air where the temperature is 20°C and $k = 0.026 \text{ W/m K}$.
- A 1 kW central heating radiator 1.5 m long and 0.6 m high with a surface temperature of 80°C dissipating heat by radiation and convection into a room at 20°C ($k = 0.026 \text{ W/m K}$ assume black body radiation and $\sigma = 56.7 \times 10^{-9} \text{ W/m K}^4$)
- Air at 4°C ($k = 0.024 \text{ W/m K}$) adjacent to a wall 3 m high and 0.15 m thick made of brick with $k = 0.3 \text{ W/m K}$, the inside temperature of the wall is 18°C , the outside wall temperature 12°C

Solution

$$a) \quad \text{Pr} = \frac{\mu C_p}{k}$$

$$k = \frac{\mu C_p}{\text{Pr}} = \frac{4.63 \times 10^{-5} \times 1175}{0.71} = 0.0766 \text{ W / m K}$$

$$\text{Nu} = \frac{hL}{k} = \frac{1000 \times 0.02}{0.0766} = 261$$

$$b) \quad \text{Nu} = \frac{hL}{k} = \frac{q}{\Delta T} \frac{L}{k}$$

$$q = \frac{Q}{A} = \frac{0.1}{0.01 \times 0.005} = 2000 \text{ W / m}^2$$

$$\Delta T = 35 - 20 = 15^\circ\text{C}$$

$$L = \frac{\text{Area}}{\text{Perimeter}} = \frac{50}{30} = \frac{5}{3} \text{ mm} = 0.001667 \text{ m}$$

$$\text{Nu} = \frac{hL}{k} = \frac{2000 \times 0.001667}{15 \times 0.026} = 8.5$$

$$c) \quad \text{Nu} = \frac{q_c}{\Delta T} \frac{L}{k}$$

In this case, q must be the convective heat flux – radiative heat flux

$$T_s = 80 + 273 = 353 \text{ K}$$

$$T_\infty = 20 + 273 = 293 \text{ K}$$

$$Q_R = \sigma A (T_s^4 - T_\infty^4) = 56.7 \times 10^{-9} \times (1.5 \times 0.6) (353^4 - 293^4) = 416 \text{ W}$$

$$\Delta T = 80 - 20 = 60 \text{ K}$$

$$Q_c = Q - Q_R = 1000 - 416 = 584 \text{ W}$$

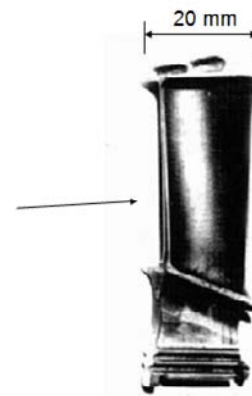

$T_\infty = 20^\circ\text{C}$

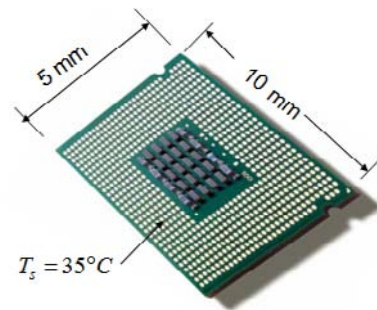

$T_s = 35^\circ\text{C}$

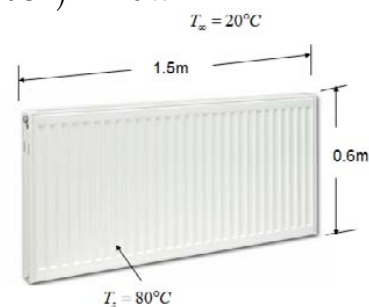

$T_s = 80^\circ\text{C}$

$$q_c = \frac{Q_c}{A} = \frac{584}{1.5 \times 0.6} = 649 \text{ W/m}^2$$

$$Nu = \frac{q_c L}{\Delta T k} = \frac{649}{60} \times \frac{0.6}{0.026} = 249$$

d) $\Delta T = 12 - 4 = 8 \text{ K}$

$$q = \frac{k_b(T_1 - T_2)}{W} = 60 \text{ }^\circ\text{C}$$

(assuming 1-D conduction)

$$q = \frac{0.3(18 - 12)}{0.18} = 12 \text{ W/m}^2$$

$$Nu = \frac{q_c L}{\Delta T k} = \frac{12}{8} \times \frac{3}{0.024} = 188$$

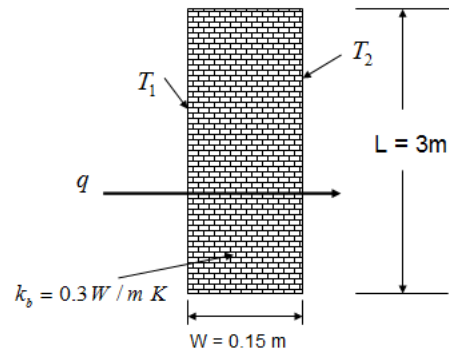

Comments:

- Nu is based on convective heat flux; sometimes the contribution of radiation can be significant and must be allowed for.
- The value of k is the definition of Nu is the fluid (not solid surface property).
- Use of appropriate boundary layer growth that characterises length scale.

Please click the advert

Are you remarkable?

Win one of the six full
tuition scholarships for
International MBA or
MSc in Management

**REGISTER
NOW**

[www.Nyenrode
MasterChallenge.com](http://www.NyenrodeMasterChallenge.com)

 **NYENRODE**
BUSINESS UNIVERSITEIT
A REWARD FOR LIFE

NYENRODE 
MASTER CHALLENGE
2013 powered by DutchNews.nl

Example 3.5

In forced convection for flow over a flat plate, the local Nusselt number can be represented by the general expression $Nu_x = C_1 Re_x^n$. In free convection from a vertical surface the local Nusselt number is represented by $Nu_x = C_2 Gr_x^m$, where C_1 , C_2 , n and m are constants

- Show that the local heat transfer coefficient is independent of the surface to air temperature difference in forced convection, whereas in free convection, h , depends upon $(T_s - T_\infty)^m$
- In turbulent free convection, it is generally recognised that $m = 1/3$. Show that the local heat transfer coefficient does not vary with coordinate x .

Solution

$$a) \quad Nu_x = \frac{hx}{k}$$

$$Re_x = \frac{\rho u x}{\mu}$$

$$\text{For forced convection: } Nu_x = C_1 Re_x^n$$

$$\text{Hence } h = \frac{k}{x} C_1 \left(\frac{\rho u x}{\mu} \right)^n$$

This shows that the heat transfer coefficient for forced does not depend on temperature difference.

$$\text{For free convection } Nu_x = C_2 Gr_x^m$$

$$Gr_x = \frac{\rho^2 g \beta \Delta T x^3}{\mu^2}$$

$$\text{Hence } h = \frac{k}{x} C_2 \left(\frac{\rho^2 g \beta \Delta T x^3}{\mu^2} \right)^m \quad (1)$$

So for free convection, heat transfer coefficient depends on ΔT^m

- From (1), with $m = 1/3$ for turbulent free convection:

$$h = \frac{k}{x} C_2 \left(\frac{\rho^2 g \beta \Delta T x^3}{\mu^2} \right)^{1/3}$$

$$h = \frac{k}{x} C_2 \left(\frac{\rho^2 g \beta \Delta T}{\mu^2} \right)^{1/3} x$$

$$h = k C_2 \left(\frac{\rho^2 g \beta \Delta T}{\mu^2} \right)^{1/3}$$

Hence the convective heat transfer coefficient does not depend on x

Example 3.6

An electrically heated thin foil of length $L = 25$ mm and width $W = 8$ mm is to be used as a wind speed metre. Wind with a temperature T_∞ and velocity U_∞ blows parallel to the longest side. The foil is internally heated by an electric heater dissipating \dot{Q} (Watts) from both sides and is to be operated in air with $T_\infty = 20^\circ\text{C}$, $C_p = 1.005$ kJ/kg K, $\nu = 1.522 \times 10^{-5}$ m²/s, $\rho = 1.19$ kg/m³ and $\text{Pr} = 0.72$. The surface temperature, T_s of the foil is to be measured at the trailing edge – but can be assumed to be constant. Estimate the wind speed when $T_\infty = 32^\circ\text{C}$ and $\dot{Q} = 0.5$ W.

Solution

Firstly, we need to estimate if the flow is laminar or turbulent.

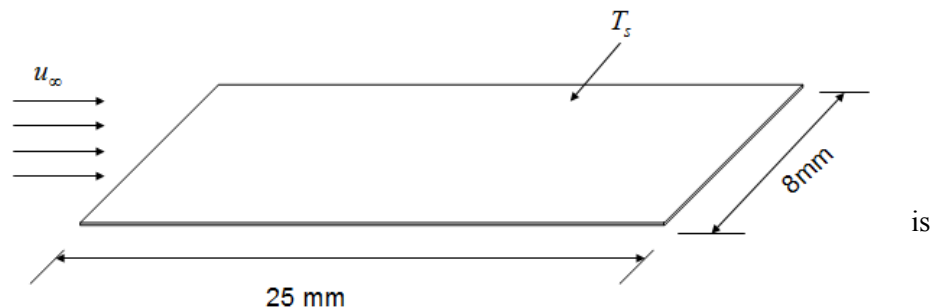

Assuming a critical (transition) Reynolds number of $\text{Re} = 3 \times 10^5$ the velocity required would be:

$$u_{\text{turb}} = \frac{3 \times 10^5}{\rho L} \mu = \frac{3 \times 10^{-3} \nu}{L} = \frac{3 \times 10^5 \times 1.522 \times 10^{-5}}{25 \times 10^{-3}} = 304 \text{ m/s}$$

Wind speed is very unlikely to reach this critical velocity, so the flow can be assumed to be laminar.

$$\text{Nu}_x = 0.331 \text{Re}_x^{1/2} \text{Pr}^{1/3}$$

$$\text{Nu}_{\text{av}} = 0.662 \text{Re}_L^{1/2} \text{Pr}^{1/3} = \frac{q_{\text{av}} L}{(T_s - T_\infty) k}$$

$$\text{Re}_L^{1/2} = \frac{q_{av} L}{(T_s - T_\infty) k \times 0.662 \text{Pr}^{1/3}}$$

$$q_{av} = \frac{0.5/2}{0.025 \times 0.008} = 1250 \text{ W/m}^2$$

$$\text{Re}_L^{1/2} = \frac{1250 \times 0.025}{(32 - 20) \times 0.0253 \times 0.662 \times (0.72)^{1/3}} = 173.5$$

$$\text{Re}_L = 3 \times 10^4$$

$$u_\infty = \frac{\text{Re}_L \nu}{L} = \frac{3 \times 10^4 \times 1.522 \times 10^{-5}}{25 \times 10^{-3}} = 18.3 \text{ m/s}$$

Please click the advert

Budget-Friendly. Knowledge-Rich.

The Agilent InfiniiVision X-Series and 1000 Series offer affordable oscilloscopes for your labs. Plus resources such as lab guides, experiments, and more, to help enrich your curriculum and make your job easier.



Scan for free
Agilent iPhone
Apps or visit
qrs.ly/po20pli



See what Agilent can do for you.

www.agilent.com/find/EducationKit

© Agilent Technologies, Inc. 2012

u.s. 1-800-829-4444 canada: 1-877-894-4414

Anticipate — Accelerate — Achieve



Agilent Technologies

Example 3.7

The side of a building of height $H = 7\text{ m}$ and length $W = 30\text{ m}$ is made entirely of glass. Estimate the heat loss through this glass (ignore the thermal resistance of the glass) when the temperature of the air inside the building is 20°C , the outside air temperature is -15°C and a wind of 15 m/s blows parallel to the side of the building. Select the appropriate correlations from those listed below of *local* Nusselt numbers to estimate the *average* heat transfer coefficients. For air take: $\rho = 1.2\text{ kg/m}^3$, $\mu = 1.8 \times 10^{-5}\text{ kg/m s}$, $C_p = 1\text{ kJ/kg K}$ and $\text{Pr} = 0.7$.

- Free convection in air, laminar ($\text{Gr}_x < 10^9$): $\text{Nu}_x = 0.3 \text{Gr}_x^{1/4}$
- Free convection in air, turbulent ($\text{Gr}_x > 10^9$): $\text{Nu}_x = 0.09 \text{Gr}_x^{1/3}$
- Forced convection, laminar ($\text{Re}_x < 10^5$): $\text{Nu}_x = 0.33 \text{Re}_x^{0.5} \text{Pr}^{1/3}$
- Forced convection, turbulent ($\text{Re}_x > 10^5$): $\text{Nu}_x = 0.029 \text{Re}_x^{0.8} \text{Pr}^{1/3}$

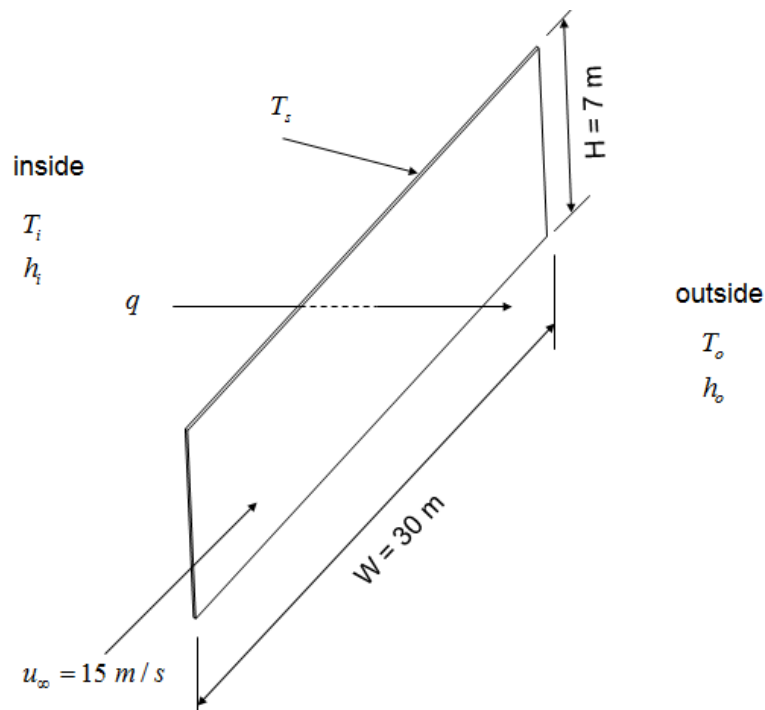
**Solution**

$$\text{Pr} = \frac{\mu C_p}{k} \quad \text{gives: } k = \frac{\mu C_p}{\text{Pr}} = \frac{1.8 \times 10^{-5} \times 1000}{0.7} = 0.026 \text{ W/mK}$$

First we need to determine if these flows are laminar or turbulent.

For the inside (Free convection):

$$\beta = \frac{1}{T} = \frac{1}{(20 + 273)} = \frac{1}{293} \text{ K}^{-1}$$

$$Gr = \frac{\rho^2 g \beta \Delta T L^3}{\mu^2} = \frac{1.2^2 \times 9.81 \times \Delta T \times 7^3}{(1.8 \times 10^{-5})^2 \times 293}$$

$$Gr = 5.1 \times 10^{10} \Delta T$$

(Flow will be turbulent over most of the surface for all reasonable values of ΔT)

For the outside (Forced convection)

$$Re_L = \frac{\rho u_\infty L}{\mu} = \frac{1.2 \times 15 \times 30}{1.8 \times 10^{-5}} = 3 \times 10^7$$

(Flow will be turbulent for most of the surface apart from the first 0.3 m)

Hence we use the following correlations:

On the inside surface: $Nu_x = 0.09 Gr^{1/3}$

On the outside surface: $Nu_x = 0.029 Re_x^{0.8} Pr^{1/3}$

For the inside:

$$Nu_x = \frac{h x}{k} = 0.09 \left(\frac{\rho^2 g \beta (T_i - T_s) x^3}{\mu^2} \right)^{1/3}$$

$$h = \text{constant} \times \frac{(x^3)^{1/3}}{x} = \text{constant}$$

Hence heat transfer coefficient is not a function of x

$$h_{av} = h_{x=L} \tag{1}$$

For the outside:

$$Nu_x = \frac{h x}{k} = 0.029 \left(\frac{\rho u x}{\mu} \right)^{0.8} Pr^{1/3}$$

$$h = \text{constant} \times \frac{(x)^{0.8}}{x} = C x^{-0.2}$$

$$h_{av} = \frac{1}{L} \int_{x=0}^{x=L} h dx = \frac{C}{L} \int_{x=0}^{x=L} x^{-0.2} dx = \frac{h_{x=L}}{0.8} \quad (2)$$

Write a heat balance:

Assuming one-dimensional heat flow and neglecting the thermal resistance of the glass

$$q = h_i(T_i - T_s)$$

$$q = h_o(T_s - T_o)$$

$$h_i(T_i - T_s) = h_o(T_s - T_o) \quad (3)$$

From equation 1

$$\frac{h_i H}{k} = 0.09 \left(\frac{\rho^2 g (T_i - T_s) H^3}{\mu^2 \times T_i} \right)^{1/3}$$

Please click the advert

Question:
What do Skype and Spotify have in common with color screen graphics and the computer mouse?

–They are all Swedish inventions.



Be innovative. Study in Sweden

$$h_i = 0.09 \left(\frac{1.2^2 \times 9.81 \times (T_i - T_s)}{(1.8 \times 10^{-5})^2 \times 293} \right) \times 0.026$$

$$h_i = 1.24(T_i - T_s)^{1/3} \quad (4)$$

From equation 2:

$$\frac{h_o W}{k} = \frac{0.029}{0.8} \left(\frac{\rho u W}{\mu} \right)^{0.8} \text{Pr}^{1/3}$$

$$h_o = \frac{0.026}{30} \times \frac{0.029}{0.8} \left(\frac{1.2 \times 15 \times 30}{1.8 \times 10^{-5}} \right)^{0.8} \times 0.7^{1/3}$$

$$h_o = 26.7 \text{ W / m}^2 \text{ K} \quad (5)$$

From (3) with (4) and (5)

$$1.24(T_i - T_s)^{4/3} = 26.7(T_s - T_o)$$

$$1.24(20 - T_s)^{4/3} = 26.7(T_s + 15)$$

$$T_s = 0.0464 (20 - T_s)^{4/3} - 15 \quad (6)$$

To solve this equation for T_s an iterative approach can be used

First guess: $T_s = -10^\circ\text{C}$

Substitute this on the right hand side of equation 6:

$$T_s = 0.0464 (20 - (-10))^{4/3} - 15 = -10.7^\circ\text{C}$$

For the second iteration we use the result of the first iteration:

$$T_s = 0.0464 (20 - (-10.7))^{4/3} - 15 = -10.6^\circ\text{C}$$

The difference between the last two iterations is 0.1°C , so we can consider this converged.

$$T_s \approx -10.6^\circ\text{C}$$

From which:

$$q = h_o(T_s - T_o) = 26.7(-10.6 + 15) = 117 \text{ W / m}^2$$

$$Q = qA = 117 \times 30 \times 7 = 24600 \text{ W} = 24.6 \text{ kW}$$

Example 3.8

The figure below shows part of a heat exchanger tube. Hot water flows through the 20 mm diameter tube and is cooled by fins which are positioned with their longest side vertical. The fins exchange heat by convection to the surrounds that are at 27°C.

Estimate the convective heat loss per fin for the following conditions. You may ignore the contribution and effect of the cut-out for the tube on the flow and heat transfer.

- natural convection, with an average fin surface temperature of 47°C;
- forced convection with an air flow of 15 m / s blowing parallel to the shortest side of the fin and with an average fin surface temperature of 37°C.

Please click the advert

With us you can
shape the future.
Every single day.

For more information go to:
www.eon-career.com

Your energy shapes the future.



The following correlations may be used without proof, although you must give reasons in support of your choice in the answer.

$$\begin{aligned} \text{Nu}_x &= 0.3 \text{Re}_x^{1/2} \text{Pr}^{1/3} & \text{Re}_x < 3 \times 10^5 \\ \text{Nu}_x &= 0.02 \text{Re}_x^{0.8} \text{Pr}^{1/3} & \text{Re}_x \geq 3 \times 10^5 \\ \text{Nu}_x &= 0.5 \text{Gr}_x^{1/4} \text{Pr}^{1/4} & \text{Gr}_x < 10^9 \\ \text{Nu}_x &= 0.1 \text{Gr}_x^{1/3} \text{Pr}^{1/3} & \text{Gr}_x \geq 10^9 \end{aligned}$$

For air at these conditions, take: $\text{Pr} = 0.7$, $k = 0.02 \text{ W / m K}$, $\mu = 1.8 \times 10^{-5} \text{ kg / m s}$ and $\rho = 1.0 \text{ kg / m}^3$

Solution

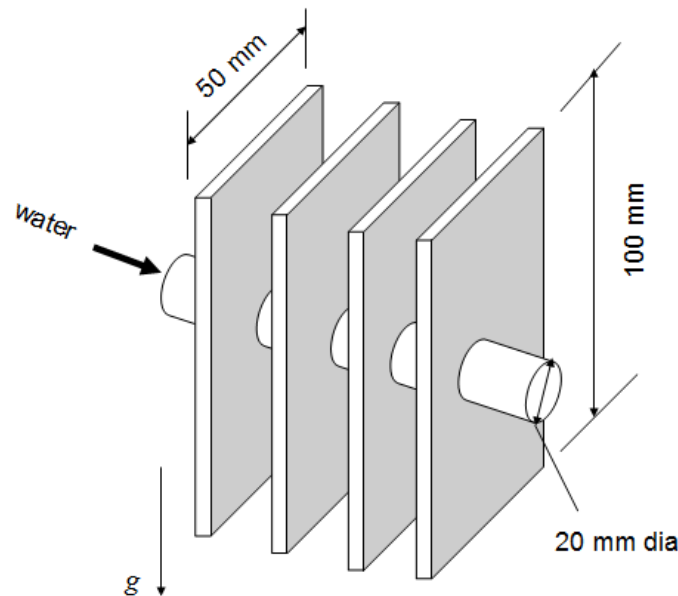

On the outside of the water tube, natural convection means that we need to evaluate Gr number to see if flow is laminar or turbulent

$$\text{Gr} = \frac{\rho^2 g \beta \Delta T L^3}{\mu^2}$$

$$\Delta T = 47 - 27 = 20 \text{ K}$$

$$\beta = \frac{1}{27 + 273} = \frac{1}{300} \text{ K}^{-1}$$

$$\text{Gr} = \frac{1^2 \times 9.81 \times 20 \times 0.1^3}{(1.8 \times 10^{-5})^2 \times 300} = 2 \times 10^6 \quad (\text{Laminar})$$

(L here is height because it is in the direction of the free convection boundary layer)

So we use:

$$Nu_x = 0.5(Gr_x Pr)^{1/4}$$

$$h_{av} = \frac{1}{L} \int_0^L h dx = \text{constant} \int_0^L x^{-1/4} dx$$

$$h_{av} = \frac{(h_{x=L})}{3/4}$$

$$Nu_{av} = \frac{2}{3}(Gr_L Pr)^{1/4}$$

$$Nu_{av} = \frac{2}{3}(2 \times 10^6 \times 0.7)^{1/4} = 23$$

$$h_{av} = \frac{Nu_{av} k}{L} = \frac{23 \times 0.02}{0.1} = 4.6 \text{ W/m}^2 \text{ K}$$

$$q_{av} = h_{av} \Delta T$$

$$Q = q_{av} A = h_{av} \Delta T A = 4.6 \times 20 \times 0.1 \times 0.05 \times 2 \quad (\text{Last factor of 2 is for both sides})$$

$$Q = 0.92 \text{ W}$$

For forced convection, we need to evaluate Re to see if flow is laminar or turbulent

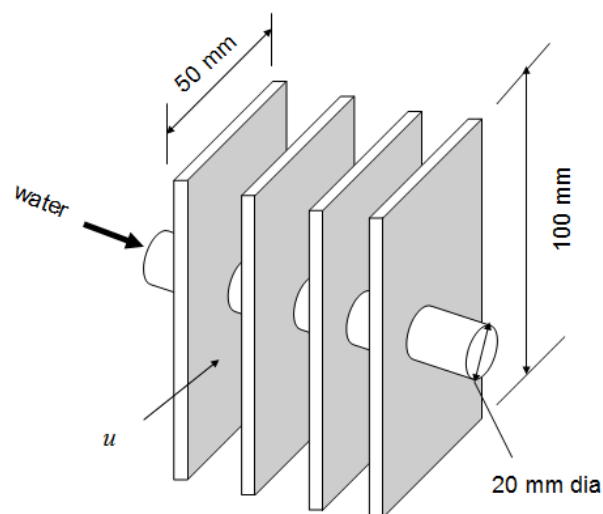

$$\text{Re} = \frac{\rho u L}{\mu} = \frac{1 \times 15 \times 0.05}{1.8 \times 10^{-5}} = 4.17 \times 10^4 \quad (\text{Laminar})$$

(L here is the width because flow is along that direction)

$$\text{Nu}_x = 0.3 \text{Re}_x^{1/2} \text{Pr}^{1/3}$$

$$h_{av} = \frac{1}{L} \int_0^L h dx = \frac{h_{x=L}}{1/2}$$

$$\text{Nu}_{av} = 0.6 \text{Re}_L^{1/2} \text{Pr}^{1/3} = 0.6 \times (4.17 \times 10^4)^{1/2} \times 0.7^{1/3} = 109$$

$$h_{av} = \frac{\text{Nu}_{av} k}{L} = \frac{109 \times 0.02}{0.05} = 43.5 \text{ W / m}^2 \text{ K}$$

$$Q = q_{av} A = h_{av} \Delta T A = 43.5 \times 10 \times 0.1 \times 0.05 \times 2 \quad (\Delta T = 10^\circ \text{C})$$

$$Q = 4.35 \text{ W}$$

Example 3.9

Consider the case of a laminar boundary layer in external forced convection undergoing transition to a turbulent boundary layer. For a constant fluid to wall temperature difference, the *local* Nusselt numbers are given by:

$$\text{Nu}_x = 0.3 \text{Re}_x^{1/2} \text{Pr}^{1/3} \quad (\text{Re}_x < 10^5)$$

$$\text{Nu}_x = 0.04 \text{Re}_x^{0.8} \text{Pr}^{1/3} \quad (\text{Re}_x \geq 10^5)$$

Show that for a plate of length, L, the *average* Nusselt number is:

$$\text{Nu}_{av} = (0.05 \text{Re}_L^{0.8} - 310) \text{Pr}^{1/3}$$

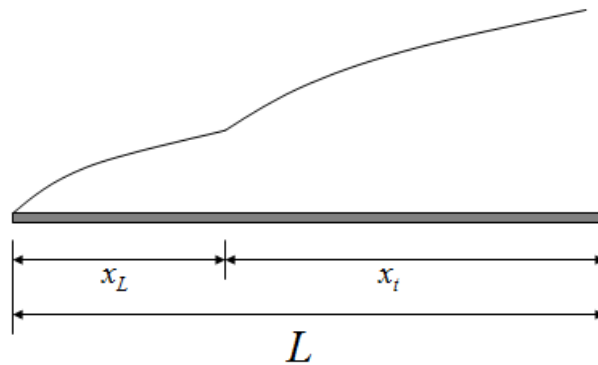
Solution

$$Nu_{av} = \frac{h_{av} k}{L}$$

Where for a constant surface-to-fluid temperature:

$$h_{av} = \frac{1}{L} \left\{ \int_0^{x_L} h_{\text{laminar}} dx + \int_{x_L}^L h_{\text{turbulent}} dx \right\}$$

Please click the advert

Nido

Luxurious accommodation

Central zone 1 & 2 locations

Meet hundreds of international students

BOOK NOW and get a £100 voucher from voucherexpress

Nido Student Living - London

Visit www.NidoStudentLiving.com/Bookboon for more info.

+44 (0)20 3102 1060

Since for laminar flow ($\text{Re}_x < 10^5$):

$$Nu_x = 0.3 \text{Re}_x^{1/2} \text{Pr}^{1/3}$$

$$h_{lam} = 0.3 \times \frac{k}{x} \left(\frac{\rho u_\infty}{\mu} \right)^{1/2} x^{1/2} \text{Pr}^{1/3}$$

$$h_{lam} = 0.3 \times k \left(\frac{\rho u_\infty}{\mu} \right)^{1/2} \text{Pr}^{1/3} x^{-1/2} = C_{lam} x^{-1/2}$$

Where C_{lam} does not depend on x

Similarly:

$$h_{turb} = C_{turb} x^{-0.2}$$

Where

$$C_{turb} = 0.04 \times k \left(\frac{\rho u_\infty}{\mu} \right)^{0.8} \text{Pr}^{1/3}$$

Hence

$$h_{av} = \frac{1}{L} \left\{ \int_0^{x_L} C_{lam} x^{-1/2} dx + \int_{x_L}^L C_{turb} x^{-0.2} dx \right\}$$

$$h_{av} = \frac{1}{L} \left\{ C_{lam} \left[\frac{x^{1/2}}{1/2} \right]_0^{x_L} + C_{turb} \left[\frac{x^{0.8}}{0.8} \right]_{x_L}^L \right\}$$

$$Nu_{av} = \frac{h_{av} k}{L}$$

$$Nu_{av} = \frac{C_{lam}}{k} 2x_L^{1/2} + \frac{C_{turb}}{0.8k} [L^{0.8} - x_L^{0.8}]$$

$$Nu_{av} = 0.6 \left(\frac{\rho u_\infty}{\mu} \right)^{1/2} x_L^{1/2} \text{Pr}^{1/3} + 0.05 \left[\left(\frac{\rho u_\infty L}{\mu} \right)^{0.8} - \left(\frac{\rho u_\infty x_L}{\mu} \right)^{0.8} \right] \text{Pr}^{1/3}$$

But $\frac{\rho u_{\infty} x_L}{\mu} = 10^5$ (The transition Reynolds number)

So

$$Nu_{av} = Pr^{1/3} \left[0.6 \times (10^5)^{1/2} + 0.05 Re_L^{0.8} - 0.05 \times (10^5)^{0.8} \right]$$

$$Nu_{av} = (0.05 Re_L^{0.8} - 310) Pr^{1/3}$$

Example 3.10

A printed circuit board dissipates 100 W from one side over an area 0.3m by 0.2m. A fan is used to cool this board with a flow speed of 12 m / s parallel to the longest dimension of the board. Using the average Nusselt number relationship given in Example 3.9 to this question, calculate the surface temperature of the board for an air temperature of 30 °C.

Take an ambient pressure of 1 bar, $R = 287 \text{ J / kg K}$,

$C_p = 1 \text{ kJ / kg K}$, $k = 0.03 \text{ W / m K}$ and $\mu = 2 \times 10^{-5} \text{ kg/m s}$

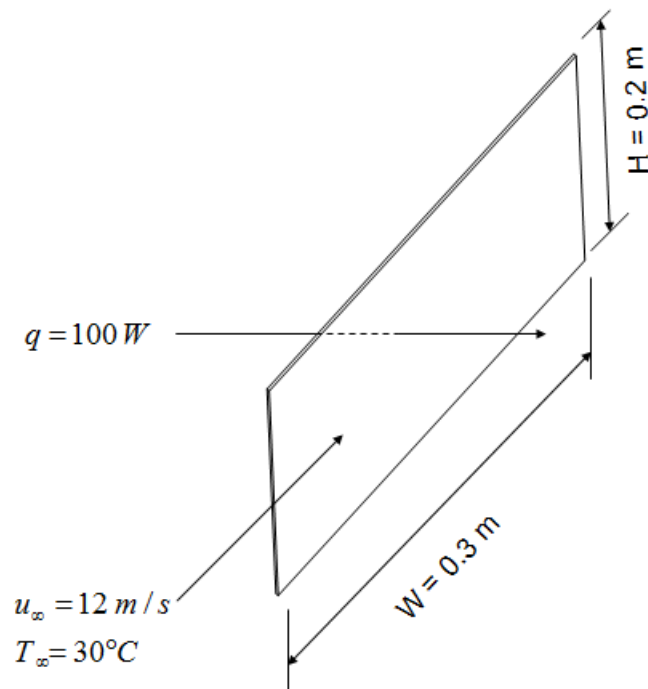

Solution

$$q_{av} = \frac{Q}{A} = \frac{100}{0.2 \times 0.3} = 1666.7 \text{ W / m}^2$$

$$\text{Pr} = \frac{\mu C_p}{k} = \frac{2 \times 10^{-5} \times 10^3}{0.03} = 0.667$$

$$\text{Re}_L = \frac{\rho u_\infty L}{\mu}$$

$$\rho = \frac{P}{RT} = \frac{10^5}{287 \times 303} = 1.15 \text{ kg/m}^3$$

$$\text{Re}_L = \frac{1.15 \times 12 \times 0.3}{2 \times 10^{-5}} = 2.07 \times 10^5$$

Using the formula for Nusselt Number obtained in Example 3.9:

$$\text{Nu}_{av} = (0.05 \text{Re}_L^{0.8} - 310) \text{Pr}^{1/3}$$

$$\text{Nu}_{av} = (0.05 \times \{2.07 \times 10^5\}^{0.8} - 310) \times (0.667)^{1/3} = 511$$

$$\text{Nu}_{av} = \frac{h_{av} k}{L} = \frac{q_{av} L}{\Delta T k}$$

$$\Delta T = \frac{q_{av} L}{\text{Nu}_{av} k} = \frac{1666.7 \times 0.3}{511 \times 0.03} = 32.6^\circ\text{C}$$

$$T_s = T_\infty + \Delta T$$

$$T_s = 30 + 32.6 = 62.6^\circ\text{C}$$

4. Radiation

Example 4.1

In a boiler, heat is radiated from the burning fuel bed to the side walls and the boiler tubes at the top. The temperatures of the fuel and the tubes are T_1 and T_2 respectively and their areas are A_1 and A_2 .

- a) Assuming that the side walls (denoted by the subscript 3) are perfectly insulated show that the temperature of the side walls is given by:

$$T_3 = \left(\frac{A_1 F_{13} T_1^4 + A_2 F_{23} T_2^4}{A_2 F_{23} + A_1 F_{13}} \right)^{1/4}$$

where F_{13} and F_{23} are the appropriate view factors.

- b) Show that the total radiative heat transfer to the tubes, Q_2 , is given by:

$$\dot{Q}_2 = \left(A_1 F_{12} + \frac{A_1 F_{13} A_2 F_{23}}{A_2 F_{23} + A_1 F_{13}} \right) \sigma (T_1^4 - T_2^4)$$

Please click the advert



Brain power

By 2020, wind could provide one-tenth of our planet's electricity needs. Already today, SKF's innovative know-how is crucial to running a large proportion of the world's wind turbines.

Up to 25 % of the generating costs relate to maintenance. These can be reduced dramatically thanks to our systems for on-line condition monitoring and automatic lubrication. We help make it more economical to create cleaner, cheaper energy out of thin air.

By sharing our experience, expertise, and creativity, industries can boost performance beyond expectations. Therefore we need the best employees who can meet this challenge!

The Power of Knowledge Engineering

Plug into The Power of Knowledge Engineering.
Visit us at www.skf.com/knowledge

SKF

- c) Calculate the radiative heat transfer to the tubes if $T_1 = 1700^\circ\text{C}$, $T_2 = 300^\circ\text{C}$, $A_1 = A_2 = 12\text{m}^2$ and the view factors are each 0.5?

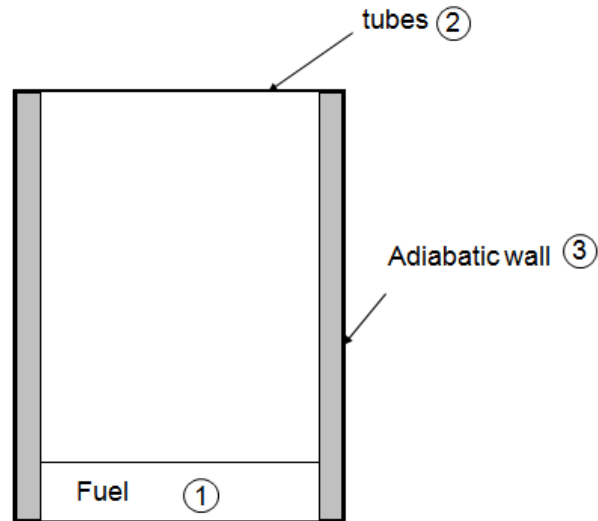

Solution

$$\text{a) } \dot{Q}_2 = \dot{Q}_{1-2} + \dot{Q}_{3-2} \quad (1)$$

Since the walls are adiabatic

$$\dot{Q}_{3-2} = \dot{Q}_{1-3} \quad (2)$$

From (2)

$$\sigma A_3 F_{32} (T_3^4 - T_2^4) = \sigma A_1 F_{13} (T_1^4 - T_3^4)$$

$$T_3^4 = \frac{A_1 F_{13} T_1^4 + A_3 F_{32} T_2^4}{A_3 F_{32} + A_1 F_{13}}$$

$$T_3 = \left(\frac{A_1 F_{13} T_1^4 + A_2 F_{23} T_2^4}{A_2 F_{23} + A_1 F_{13}} \right)^{1/4} \quad \text{since } A_i F_{ij} = A_j F_{ji}$$

- b) From (1)

$$\dot{Q}_2 = \sigma A_1 F_{12} (T_1^4 - T_2^4) + \sigma A_3 F_{32} (T_3^4 - T_2^4)$$

$$\dot{Q}_2 = \sigma A_1 F_{12} (T_1^4 - T_2^4) + \sigma A_2 F_{23} (T_3^4 - T_2^4)$$

$$\dot{Q}_2 = \sigma A_1 F_{12} (T_1^4 - T_2^4) + \sigma A_2 F_{23} \left(\frac{A_1 F_{13} T_1^4 + A_3 F_{32} T_2^4}{A_3 F_{32} + A_1 F_{13}} - T_2^4 \right)$$

$$\dot{Q}_2 = \sigma A_1 F_{12} (T_1^4 - T_2^4) + \sigma A_2 F_{23} \left(\frac{A_1 F_{13} T_1^4 + A_3 F_{32} T_2^4 - A_3 F_{32} T_2^4 - A_1 F_{13} T_2^4}{A_3 F_{32} + A_1 F_{13}} \right)$$

$$\dot{Q}_2 = \sigma A_1 F_{12} (T_1^4 - T_2^4) + \sigma A_2 F_{23} \left(\frac{A_1 F_{13} T_1^4 - A_1 F_{13} T_2^4}{A_3 F_{32} + A_1 F_{13}} \right)$$

$$\dot{Q}_2 = \sigma A_1 F_{12} (T_1^4 - T_2^4) + \sigma A_2 F_{23} (T_1^4 - T_2^4) \left(\frac{A_1 F_{13}}{A_3 F_{32} + A_1 F_{13}} \right)$$

$$\dot{Q}_2 = \sigma A_1 F_{12} (T_1^4 - T_2^4) + \sigma (T_1^4 - T_2^4) \left(\frac{A_2 F_{23} A_1 F_{13}}{A_3 F_{32} + A_1 F_{13}} \right)$$

$$\dot{Q}_2 = \sigma (T_1^4 - T_2^4) \left(A_1 F_{12} + \frac{A_2 F_{23} A_1 F_{13}}{A_3 F_{32} + A_1 F_{13}} \right)$$

$$c) \quad T_3^4 = \frac{A_1 F_{13} T_1^4 + A_3 F_{32} T_2^4}{A_3 F_{32} + A_1 F_{13}} = \frac{A_1 F_{13} T_1^4 + A_2 F_{23} T_2^4}{A_2 F_{23} + A_1 F_{13}}$$

$$T_3^4 = \frac{12 \times 0.5 \times 1973^4 + 12 \times 0.5 \times 573^4}{12 \times 0.5 + 12 \times 0.5} = 1662 \text{ K}$$

$$\dot{Q}_2 = 56.7 \times 10^{-9} (1973^4 - 573^4) \left(6 + \frac{6 \times 6}{6 + 6} \right) = 7.68 \times 10^6 \text{ W}$$

Example 4.2

Two adjacent compressor discs (Surfaces 1 and 2) each of 0.4 m diameter are bounded at the periphery by a 0.1 wide shroud (Surface 3).

- Given that $F_{12} = 0.6$, calculate all the other view factors for this configuration.
- The emissivity and temperature of Surfaces 1 and 2 are $\varepsilon_1 = 0.4$, $T_1 = 800 \text{ K}$, $\varepsilon_2 = 0.3$, $T_2 = 700 \text{ K}$ and Surface 3 can be treated as radiatively black with a temperature of $T_3 = 900 \text{ K}$. Apply a grey body radiation analysis to Surface 1 and to Surface 2 and show that:

$$2.5 J_1 - 0.9 J_2 = 45545 \quad \text{W/m}^2$$

and

$$3.333 J_2 - 1.4 J_1 = 48334 \quad \text{W/m}^2.$$

The following equation may be used without proof:

$$\frac{E_{B,i} - J_i}{\frac{1 - \varepsilon_i}{\varepsilon_i}} = \sum_{j=1}^N F_{i,j} (J_i - J_j)$$

- c) Determine the radiative heat flux to Surface 2

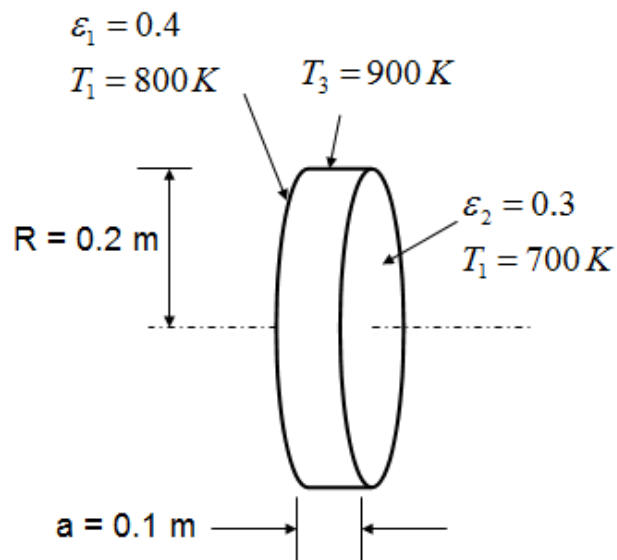

Solution

a) $r_1 = r_2 = r = 0.2 \text{ m}$

$$a = 0.1 \text{ m}$$

$$\frac{r_2}{a} = \frac{0.2}{0.1} = 2$$

$$\frac{a}{r_1} = \frac{0.1}{0.2} = 0.5$$

$F_{12} = 0.6$ (Although this is given in the question, it can be obtained from appropriate tables with the above parameters)

$$F_{11} = 0 \quad (\text{As surface 1 is flat, it cannot see itself})$$

$$F_{13} = 1 - 0.6 = 0.4 \quad (\text{From the relation } \sum F_{ij} = 1 \text{ in an enclosure})$$

$$F_{21} = 0.6 \quad (\text{Symmetry})$$

$$F_{22} = 0$$

$$F_{23} = 0.4$$

$$F_{31} = \frac{A_1}{A_3} F_{13} = \frac{\pi \times 0.2^2}{2 \times \pi \times 0.2 \times 0.1} \times 0.4 = 0.4$$

$$F_{32} = 0.4 \quad (\text{Symmetry})$$

$$F_{33} = 1 - 0.4 - 0.4 = 0.2$$

Please click the advert



Are you considering a European business degree?

LEARN BUSINESS at university level. We mix cases with cutting edge research working individually or in teams and everyone speaks English. Bring back valuable knowledge and experience to boost your career.

MEET a culture of new foods, music and traditions and a new way of studying business in a safe, clean environment – in the middle of Copenhagen, Denmark.

ENGAGE in extra-curricular activities such as case competitions, sports, etc. – make new friends among CBS' 18,000 students from more than 80 countries.

EFMD **EQUIS** ACCREDITED

AACSB ACCREDITED

ACCREDITED BY ASSOCIATION OF MBAs

CEMS

P.T.M.

See what we look like and how we work on cbs.dk

Download free ebooks at bookboon.com

$$\text{b) } \frac{E_{b,i} - J_i}{\frac{1 - \varepsilon_i}{\varepsilon_i}} = \sum_{j=1}^n (J_i - J_j) F_{ij}$$

Apply to surface 1, ($i = 1$)

$$\text{Let } \frac{1 - \varepsilon_1}{\varepsilon_1} = \phi_1$$

$$(E_{b,1} - J_1) = \phi_1 [F_{12}(J_1 - J_2) + F_{13}(J_1 - J_3)]$$

$$E_{b,1} = J_1 \{1 + \phi_1 F_{12} + \phi_1 F_{13}\} - \phi_1 F_{12} J_2 - \phi_1 F_{13} J_3$$

$$E_{b,1} = \sigma T_1^4$$

$$J_3 = \sigma T_3^4 \quad (\text{Radiatively black surface})$$

$$\phi_1 = \frac{1 - \varepsilon_1}{\varepsilon_1} = \frac{1 - 0.4}{0.4} = 1.5$$

$$\sigma T_1^4 = 2.5 J_1 - 0.9 J_2 - 0.6 \sigma T_3^4$$

$$56.7 \times 10^{-9} \times 800^4 = 2.5 \times J_1 - 0.9 \times J_2 - 0.6 \times 56.7 \times 10^{-9} \times 900^4$$

$$2.5 J_1 - 0.9 J_2 = 45545 \text{ W/m}^2 \quad (1)$$

Applying to surface 2 ($i = 2$)

$$E_{b,2} = J_2 \{1 + \phi_2 F_{21} + \phi_2 F_{23}\} - \phi_2 F_{21} J_1 - \phi_2 F_{23} J_3$$

$$E_{b,2} = \sigma T_2^4$$

$$\phi_2 = \frac{1 - \varepsilon_2}{\varepsilon_2} = \frac{1 - 0.3}{0.3} = 2.333$$

$$\sigma T_2^4 = 3.333 J_2 - 1.4 J_1 - 0.9333 \sigma T_3^4$$

$$3.333 J_2 - 1.4 J_1 = 48334 \text{ W/m}^2 \quad (2)$$

c) From (2):

$$J_1 = \frac{3.333J_2 - 48334}{1.4}$$

Substituting in (1)

$$2.5 \times \frac{3.333J_2 - 48334}{1.4} - 0.9J_2 = 45545 \text{ W/m}^2$$

$$J_2 = 26099 \text{ W/m}^2$$

The net radiative flux to surface 2 is given by

$$q_2 = \frac{E_{b,2} - J_2}{\frac{1 - \varepsilon_2}{\varepsilon_2}} = \frac{56.7 \times 10^{-9} \times 700^4 - 26099}{\frac{1 - 0.3}{0.3}} = -5.351 \times 10^3 \text{ W/m}^2$$

The minus sign indicates a net influx of radiative transfer as would be expected from consideration of surface temperatures.

Please click the advert

The financial industry needs a strong software platform

That's why we need you

Working at SimCorp means making a difference. At SimCorp, you help create the tools that shape the global financial industry of tomorrow. SimCorp provides integrated software solutions that can turn investment management companies into winners. With SimCorp, you make the most of your ambitions, realising your full potential in a challenging, empowering and stimulating work environment.

Are you among the best qualified in finance, economics, computer science or mathematics?

Find your next challenge at www.simcorp.com/careers

Mitigate risk | Reduce cost | Enable growth
simcorp.com



“When I joined SimCorp, I was very impressed with the introduction programme offered to me.”

Meet Lars and other employees at simcorp.com/meetouremployees



Example 4.3

The figure below shows a simplified representation of gas flame inside a burner unit. The gas flame is modelled as a cylinder of radius $r_1 = 10$ mm (Surface 1). The burner comprises Surface 2 (a cylinder of radius $r_2 = 40$ mm and height $h = 40$ mm), concentric with Surface 1 and a concentric base (Surface 3), of radius $r_3 = 40$ mm. The end of the cylinder, Surface 4, opposite to the base is open to the surrounding environment.

- a) Given that $F_{21} = 0.143$ and $F_{22} = 0.445$ use the dimensions indicated on the diagram to calculate all the other relevant view factors.
- b) The flame, base and surroundings can be represented as black bodies at constant temperatures T_1 , T_3 and T_4 , respectively. The emissivity of the inside of Surface 2 is $\varepsilon_2 = 0.5$. Apply a grey body radiation analysis to Surface 2 and show that the radiosity is given by:

$$J_2 = \frac{\sigma(T_2^4 + F_{21}T_1^4 + F_{23}T_3^4 + F_{24}T_4^4)}{1 + F_{21} + F_{23} + F_{24}}$$

The following equation may be used without proof:

$$\frac{E_{b,i} - J_i}{(1 - \varepsilon_i)/\varepsilon_i} = \sum_{j=1}^N F_{ij} (J_i - J_j)$$

- c) The temperatures T_1 and T_3 are found to be: $T_1 = 1800$ K and $T_3 = 1200$ K, and the surrounds are at 500 K. Estimate the temperature T_2 , using a radiative heat balance on the outer surface of Surface 2, where the emissivity is $\varepsilon_0 = 0.8$

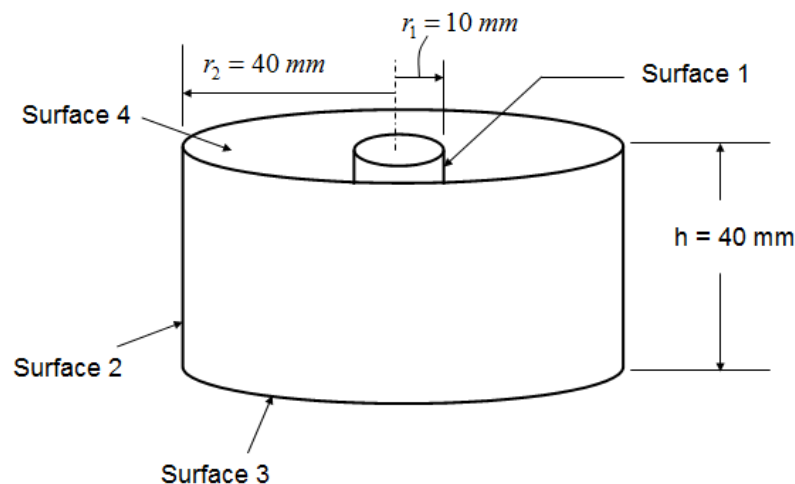
**Solution**

a) $A_1 = 2\pi r_1 h$

$$A_2 = 2\pi r_2 h$$

$$A_3 = A_4 = \pi(r_2^2 - r_1^2)$$

$$F_{11} = 0$$

$$F_{13} = F_{14}$$

$$F_{11} + F_{12} + F_{13} + F_{14} = 1$$

but

$$A_1 F_{12} = A_2 F_{21}$$

$$F_{12} = \frac{A_2}{A_1} F_{21} = \frac{r_2}{r_1} F_{21} = \frac{40}{10} \times 0.14338 = 0.57352$$

Thus

$$F_{13} = F_{14} = \frac{1 - 0.57352}{2} = 0.21324$$

$$F_{21} + F_{22} + F_{23} + F_{24} = 1$$

$$F_{23} = F_{24} = \frac{1 - F_{21} - F_{22}}{2} = \frac{1 - 0.14338 - 0.44515}{2} = 0.20574$$

$$F_{31} + F_{32} + F_{33} + F_{34} = 1$$

$$F_{33} = 0$$

$$A_1 F_{13} = A_3 F_{31}$$

$$F_{31} = \frac{A_1}{A_3} F_{13} = \frac{2\pi r_1 h}{\pi(r_2^2 - r_1^2)} F_{13} = \frac{2 \times 0.01 \times 0.04}{0.04^2 - 0.01^2} \times 0.21324 = 0.11373$$

$$A_2 F_{23} = A_3 F_{32}$$

$$F_{32} = \frac{A_2}{A_3} F_{23} = \frac{2\pi r_2 h}{\pi(r_2^2 - r_1^2)} F_{23} = \frac{2 \times 0.04 \times 0.04}{0.04^2 - 0.01^2} \times 0.20574 = 0.43891$$

$$F_{34} = 1 - 0.11373 - 0.43891 = 0.44736$$

Similarly (using symmetry)

$$F_{41} = F_{31} = 0.11373$$

$$F_{42} = F_{32} = 0.43891$$

$$F_{43} = F_{34} = 0.44736$$

$$F_{44} = 0$$

$$b) \frac{E_{b,i} - J_i}{1 - \varepsilon_i} = \sum_{j=1}^n (J_i - J_j) F_{ij}$$

$$\varepsilon_i$$

Please click the advert

What do you want to do?

No matter what you want out of your future career, an employer with a broad range of operations in a load of countries will always be the ticket. Working within the Volvo Group means more than 100,000 friends and colleagues in more than 185 countries all over the world. We offer graduates great career opportunities – check out the Career section at our web site www.volvogroup.com. We look forward to getting to know you!

VOLVO
AB Volvo (publ)
www.volvogroup.com

VOLVO TRUCKS | RENAULT TRUCKS | MACK TRUCKS | VOLVO BUSES | VOLVO CONSTRUCTION EQUIPMENT | VOLVO PENTA | VOLVO AERO | VOLVO IT
VOLVO FINANCIAL SERVICES | VOLVO 3P | VOLVO POWERTRAIN | VOLVO PARTS | VOLVO TECHNOLOGY | VOLVO LOGISTICS | BUSINESS AREA ASIA

Download free ebooks at bookboon.com

For surface 2, $i = 2$, $j = 1, 3, 4$

$$\frac{E_{b,2} - J_2}{1 - \varepsilon_2} = F_{12}(J_2 - J_1) + F_{23}(J_2 - J_3) + F_{24}(J_2 - J_4)$$

$$\varepsilon_2$$

$$\varepsilon_2 = 0.5, \quad \frac{1 - 0.5}{0.5} = 1$$

$$J_1 = E_{b,1}, \quad J_3 = E_{b,3}, \quad J_4 = E_{b,4} \quad (1, 3, 4 \text{ are black})$$

$$E_{b,2} - J_2 = F_{12}(J_2 - E_{b,1}) + F_{23}(J_2 - E_{b,3}) + F_{24}(J_2 - E_{b,4})$$

$$J_2(F_{21} + F_{23} + F_{24} + 1) = \sigma T_2^4 + \sigma T_1^4 F_{21} + \sigma T_3^4 F_{23} + \sigma T_4^4 F_{24}$$

$$J_2 = \frac{\sigma(T_2^4 + T_1^4 F_{21} + T_3^4 F_{23} + T_4^4 F_{24})}{F_{21} + F_{23} + F_{24} + 1}$$

$$c) \quad J_2 = \frac{56.7 \times 10^{-9} (T_2^4 + 1800^4 \times 0.57352 + 1200^4 \times 0.20574 + 500^4 \times 0.20574)}{0.57352 + 20574 + 0.20574 + 1}$$

$$J_2 = 36.47 \times 10^{-9} T_2^4 + 70913$$

On the outside of surface 2:

$$-q_2 = \sigma \varepsilon_{2,0} (T_2^4 - T_4^4)$$

Also

$$q_2 = \frac{E_{b,2} - J_2}{1 - \varepsilon_2} = \sigma T_2^4 - 36.47 \times 10^{-9} T_2^4 + 70913$$

$$\varepsilon_2$$

$$20.23 \times 10^{-9} T_2^4 + 70913 = -56.7 \times 10^{-9} \times 0.8 (T_2^4 - 500^4)$$

$$T_2 = 1029 \text{ K}$$

Example 4.4

The figure below shows a schematic diagram, at a particular instant of the engine cycle, of a cylinder head (Surface 1), piston crown (Surface 2) and cylinder liner (Surface 3).

- Using the dimensions indicated on the diagram, and given that $F_{12} = 0.6$, calculate all the other relevant view factors.
- The cylinder head can be represented as a black body at a temperature $T_1 = 1700$ K and the emissivity of the piston crown is $\varepsilon_2 = 0.75$. Apply a grey body radiation analysis to the piston crown (Surface 2) and show that the radiosity is given by:

$$J_2 = 42.5 \times 10^{-9} T_2^4 + 71035 + 0.1 J_3$$

The following equation may be used without proof:

$$\frac{E_{b,i} - J_i}{(1 - \varepsilon_i)/\varepsilon_i} = \sum_{j=1}^N F_{ij} (J_i - J_j)$$

- Similar analysis applied to the cylinder liner gives:

$$J_3 = 107210 + 0.222 J_2$$

If the surface temperature of the piston crown is, $T_2 = 600$ K, calculate the radiative heat flux into the piston crown.

- Briefly explain how this analysis could be extended to make it more realistic

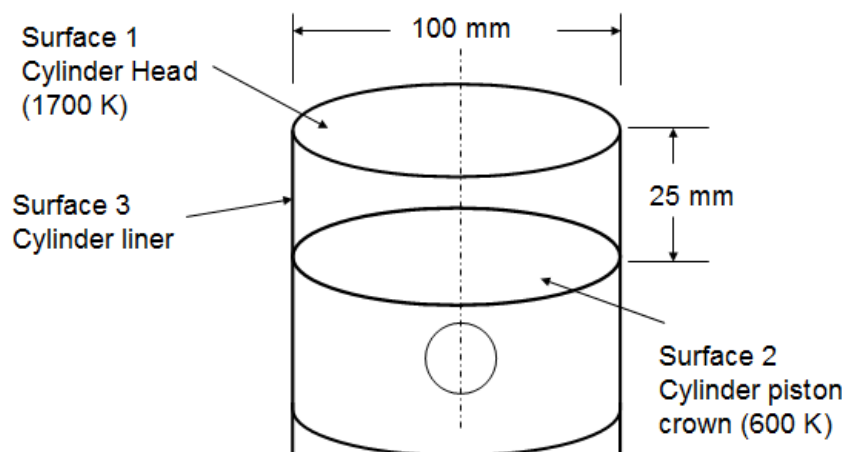
**Solution**

- $A_1 = A_2 = \pi r^2 = \pi \times 50^2 = 2500\pi \text{ mm}^2$

$$A_3 = \pi DL = \pi \times 100 \times 25 = 2500 \pi \text{ mm}^2$$

$$F_{11} = 0 \text{ (Flat surface)}$$

$$F_{12} = 0.6 \text{ (Given)}$$

$$F_{13} = 1.0 - F_{12} = 1.0 - 0.6 = 0.4$$

By Symmetry:

$$F_{21} = F_{12} = 0.6$$

$$F_{23} = F_{32} = 0.4$$

$$F_{22} = 0$$

$$F_{31} = \frac{A_1}{A_3} F_{13} = 0.4 \text{ Since } A_1 = A_3$$

Please click the advert

RedStarResume.

Do you want your Dream Job?

More customers get their dream job by using RedStarResume than any other resume service.

RedStarResume can help you with your job application and CV.

Go to: Redstarresume.com
Use code "BOOKBOON" and save up to \$15

(enter the discount code in the "Discount Code Box")

$$F_{32} = 0.4 \quad (\text{By symmetry})$$

$$F_{33} = 1.0 - F_{31} - F_{32} = 1.0 - 0.4 - 0.4 = 0.2$$

b) For surface 2, $i = 2$

$$\frac{E_{b,2} - J_2}{1 - \varepsilon_2} = F_{21}(J_2 - J_1) + F_{23}(J_2 - J_3)$$

$$\frac{E_{b,2}}{\varepsilon_2}$$

$$J_1 = \sigma T_1^4 \quad (\text{Black body})$$

$$\varepsilon_2 = 0.75, \quad \frac{1 - 0.75}{0.75} = \frac{1}{3}$$

$$E_{b,2} = \sigma T_2^4$$

$$\frac{\sigma T_2^4 - J_2}{1/3} = F_{21}(J_2 - \sigma T_1^4) + F_{23}(J_2 - J_3)$$

$$J_2 = \frac{\sigma T_2^4 + \frac{1}{3}(F_{21}\sigma T_1^4 + F_{23}J_3)}{1 + \frac{1}{3}(F_{21} + F_{23})}$$

$$J_2 = \frac{56.7 \times 10^{-9} \times T_2^4 + \frac{1}{3}(0.6 \times 56.7 \times 10^{-9} \times 1700^4 + 0.4J_3)}{1 + \frac{1}{3}(0.6 + 0.4)}$$

$$J_2 = 42.5 \times 10^{-9} T_2^4 + 71035 + 0.1J_3$$

We are also given that

$$J_3 = 107210 + 0.222J_2$$

$$0.1J_3 = 10721 + 0.0222J_2$$

Hence

$$J_2 = 42.5 \times 10^{-9} \times 600^4 + 71035 + 10721 + 0.0222 J_2$$

$$0.97778 J_2 = 5508 + 81756$$

$$J_2 = 89247 \text{ W/m}^2$$

Also

$$q_2 = \frac{\frac{E_{b,2} - J_2}{1 - \varepsilon_2}}{\varepsilon_2} = \frac{56.7 \times 10^9 \times 600^4 - 89247}{1/3} = -246 \times 10^3 \text{ W/m}^2$$

Negative sign indicates $J_2 > E_{b,2} > E_2$, so net flux is into the piston crown.

- c) To make the analysis more realistic, it needs to be extended by including convection from the piston crown, and cylinder liner. Radiation from the piston underside also needs to be included. We then carry out analysis over a complete engine cycle.

Example 4.5

The figure below shows the variation of view factor F_{ij} with geometric parameters h/L and W/L for the case of two rectangular surfaces at right angles to each other. This plot is to be used to model the radiative heat transfer between a turbocharger housing and the casing of an engine management system. The horizontal rectangle, $W = 0.12$ m and $L = 0.2$ m, is the engine management system and is denoted Surface 1. The vertical rectangle, $h = 0.2$ m and $L = 0.2$ m, is the turbocharger casing and denoted by Surface 2. The surrounds, which may be approximated as a black body, have a temperature of 60°C .

- a) Using the graph and also view factor algebra, evaluate the view factors: $F_{1,2}$, $F_{2,1}$, $F_{1,3}$ and $F_{2,3}$
- b) By applying a grey-body radiation analysis to Surface 1 with $\varepsilon_1 = 0.5$, show that the radiosity J_1 is:

$$J_1 = 28.35 \times 10^{-9} T_1^4 + 0.135 J_2 + 254 \text{ (W/m}^2\text{)}$$

The following equation may be used without proof:

$$\frac{E_{b,i} - J_i}{(1 - \varepsilon_i)/\varepsilon_i} = \sum_{j=1}^N F_{ij} (J_i - J_j)$$

c) A similar analysis is applied to Surface 2 with $\epsilon_2 = 0.4$ obtained the result:

$$J_2 = 22.7 \times 10^{-9} T_2^4 + 0.097 J_1 + 350 \text{ (W/m}^2\text{)}.$$

Use this to estimate the surface temperature of the engine management system when the turbocharger housing has a surface temperature of $T_2 = 700\text{K}$.

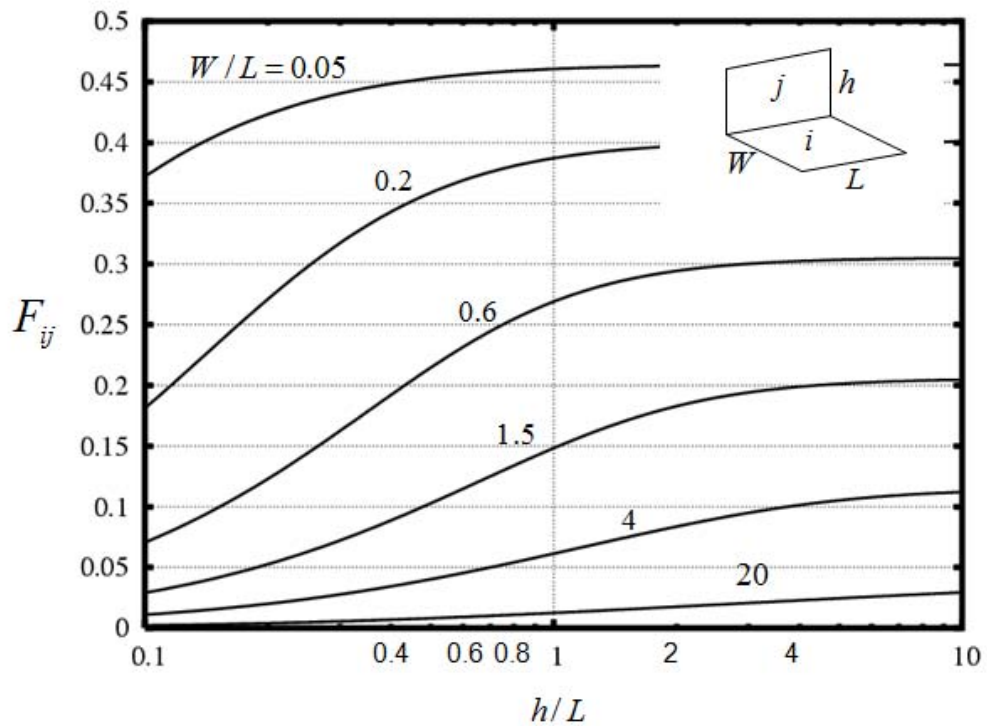

Solution

$$\frac{h}{L} = \frac{0.2}{0.2} = 1, \quad \frac{W}{L} = \frac{0.12}{0.2} = 0.6$$

From the figure: $F_{12} = 0.27$

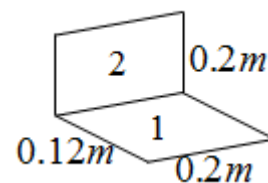

$$A_1 F_{12} = A_2 F_{21}$$

$$F_{21} = \frac{A_1}{A_2} F_{12} = \frac{w}{h} F_{12} = \frac{0.12}{0.2} \times 0.27 = 0.162$$

$$F_{11} + F_{12} + F_{13} = 1$$

$$F_{11} = 0$$

$$F_{13} = 1 - F_{12} = 1 - 0.27 = 0.73$$

$$F_{21} + F_{22} + F_{23} = 1$$

$$F_{22} = 0$$

$$F_{23} = 1 - F_{21} = 1 - 0.162 = 0.838$$

For a grey body radiative heat transfer in an enclosure (n surfaces)

$$\frac{E_{b,i} - J_i}{\frac{1 - \varepsilon_i}{\varepsilon_i}} = \sum_{j=1}^n (J_i - J_j) F_{ij}$$

Applying for surface 1, $i = 1$ (the casing)

Try this...



The sequence 2, 4, 6, 8, 10, 12, 14, 16, ... is the sequence of even whole numbers. The 100th place in this sequence is the number...?

Challenging? Not challenging? Try more >>

www.alloptions.nl/life

Please click the advert

$$\frac{E_{b,1} - J_1}{\frac{1 - \varepsilon_1}{\varepsilon_1}} = F_{12}(J_1 - J_2) + F_{13}(J_1 - J_3)$$

$$E_{b,1} = \sigma T_1^4$$

$$J_3 = \sigma T_3^4$$

$$\frac{1 - \varepsilon_1}{\varepsilon_1} = \frac{1 - 0.5}{0.5} = 1.0$$

So

$$J_1 = \frac{\sigma T_1^4 + F_{12}J_2 + F_{13}\sigma T_3^4}{1 + F_{12} + F_{13}}$$

$$J_1 = \frac{56.7 \times 10^{-9} T_1^4 + 0.27J_2 + 0.73 \times 56.7 \times 10^{-9} \times 333^4}{1 + 0.27 + 0.73}$$

$$J_1 = 28.35 \times 10^{-9} T_1^4 + 0.135 J_2 + 254 \quad W/m^2 \quad (1)$$

c)

$$\text{Given: } J_2 = 22.68 \times 10^{-9} T_2^4 + 0.0972 J_1 + 350 \quad W/m^2$$

$$J_2 = 22.68 \times 10^{-9} \times 700^4 + 0.0972 J_1 + 350 \quad W/m^2$$

$$J_2 = 5796 + 0.0972 J_1 \quad (2)$$

Substituting from equation 2 into equation 1:

$$J_1 = 28.35 \times 10^{-9} T_1^4 + 0.135 (5796 + 0.0972 J_1) + 254 \quad W/m^2$$

Which gives:

$$J_1 = 28.7 \times 10^{-9} T_1^4 + 1050 \quad W/m^2$$

Applying a heat balance to surface 1

$$q_{in} = q_{out}$$

$$q_{in} = - \left[\frac{E_{b,1} - J_1}{\frac{1 - \epsilon_1}{\epsilon_1}} \right] = -57.9 \times 10^{-9} T_1^4 - 28.7 \times 10^{-9} T_1^4 + 1050$$

$$q_{in} = -28. \times 10^{-9} T_1^4 + 1050$$

$$q_{out} = \epsilon_1 \sigma (T_1^4 - T_\infty^4) = 0.5 \times 56.7 \times 10^{-9} (T_1^4 - 333^4)$$

Combining and solving for T_1 , gives:

$$T_1 = 396 \text{ K}$$

Note that $q_{in} = -q$ since q is out of the surface when $q > 0$.

Please click the advert

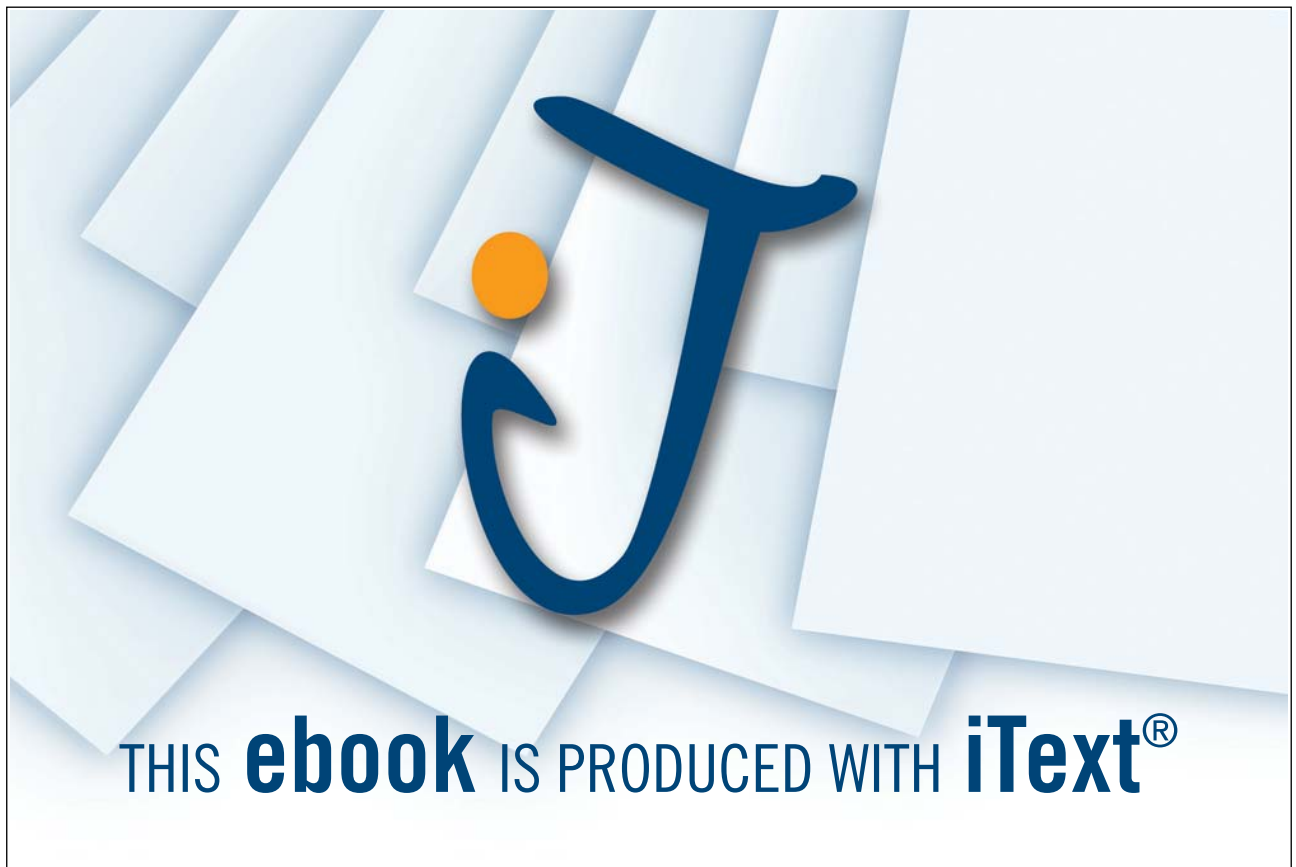

5. Heat Exchangers

Example 5.1

A heat exchanger consists of numerous rectangular channels, each 18 mm wide and 2.25 mm high. In an adjacent pair of channels, there are two streams: water $k = 0.625 \text{ W/m K}$ and air $k = 0.0371 \text{ W/m K}$, separated by a 18 mm wide and 0.5 mm thick stainless steel plate of $k = 16 \text{ W/m K}$. The fouling resistances for air and water are $2 \times 10^{-4} \text{ m}^2 \text{ K/W}$ and $5 \times 10^{-4} \text{ m}^2 \text{ K/W}$, respectively, and the Nusselt number given by $Nu_{Dh} = 5.95$ where the subscript 'D_h' refers to the hydraulic diameter.

- Calculate the overall heat transfer coefficient ignoring both the thermal resistance of the separating wall and the two fouling resistances.
- Calculate the overall heat transfer coefficient with these resistances.
- Which is the controlling heat transfer coefficient?

Solution:

Hydraulic Diameter = $4 \times \text{Area} / \text{Wetted perimeter}$

$$D_h = 4 \times \frac{2.25 \times 10^{-3} \times 18 \times 10^{-3}}{(2.25 + 18) \times 10^{-3}} = 4 \times 10^{-3}$$

$$h = \frac{Nu_D k}{D_h}$$

$$(a) \quad h_{\text{water}} = \frac{5.95 \times 0.625}{4 \times 10^{-3}} = 930 \text{ W/m}^2 \text{ K}$$

$$h_{\text{air}} = \frac{5.95 \times 0.0371}{4 \times 10^{-3}} = 55.186 \text{ W/m}^2 \text{ K}$$

$$U = \left[\frac{1}{930} + \frac{1}{55.186} \right]^{-1} = 52.1 \text{ W/m}^2 \text{ K}$$

$$b) \quad U = \left[\frac{0.5 \times 10^{-3}}{16} + \frac{1}{930} + 2 \times 10^{-4} + \frac{1}{55.186} + 5 \times 10^{-4} \right]^{-1} = 50.2 \text{ W/m}^2 \text{ K}$$

- The controlling heat transfer coefficient is the air heat transfer coefficient.

Example 5.2

A heat exchanger tube of $D = 20$ mm diameter conveys 0.0983 kg/s of water ($Pr = 4.3$, $k = 0.632$ W/m K, $\rho = 1000$ kg/m³, $\mu = 0.651 \times 10^{-3}$ kg/ms) on the inside which is used to cool a stream of air on the outside where the external heat transfer coefficient has a value of $h_o = 100$ W/m² K. Ignoring the thermal resistance of the tube walls, evaluate the overall heat transfer coefficient, U , assuming that the internal heat transfer coefficient is given by the Dittus-Boelter relation for fully developed turbulent pipe flow:

$$Nu_D = 0.023 Re_D^{0.8} Pr^{0.4}$$

Solution:

$$\dot{m} = \rho VA$$

$$V = \frac{\dot{m}}{\rho A}$$

$$Re_D = \frac{\rho VD}{\mu} = \frac{4\dot{m}}{\pi D \mu} = \frac{4 \times 0.0983}{\pi \times 0.02 \times 0.651 \times 10^{-3}} = 9613$$

$$Nu_D = 0.023 \times 9613^{0.8} \times 4.3^{0.4} = 63$$

$$Nu_D = \frac{hD}{k}$$

$$h = \frac{Nu_D k}{D} = \frac{63.3 \times 0.632}{0.02} = 2000 \text{ W/m}^2 \text{ K}$$

$$U = \left[\frac{1}{2000} + \frac{1}{100} \right]^{-1} = 95.2 \text{ W/m}^2 \text{ K}$$

Example 5.3

- a) Show that the overall heat transfer coefficient for a concentric tube heat exchanger is given by the relation:

$$U_o = \left[\frac{r_o}{k} \ln \left(\frac{r_o}{r_i} \right) + \frac{r_o}{h_i r_i} + \frac{1}{h_o} \right]^{-1}$$

With the terminology given by the figure below

- b) A heat exchanger made of two concentric tubes is used to cool engine oil for a diesel engine. The inner tube is made of 3mm wall thickness of stainless steel with conductivity $k = 16 \text{ W/m K}$. The inner tube radius is 25mm and has a water flow rate of 0.25 kg/s. The outer tube has a diameter of 90mm and has an oil flow rate of 0.12 kg/s. Given the following properties for oil and water:

oil:

$$C_p = 2131 \text{ J/kg K}, \quad \mu = 3.25 \times 10^{-2} \text{ kg/m s}, \quad k = 0.138 \text{ W/m K}$$

Water:

$$C_p = 4178 \text{ J/kg K}, \quad \mu = 725 \times 10^{-6} \text{ kg/m s}, \quad k = 0.625 \text{ W/m K}$$

Using the relations:

$$\begin{aligned} Nu_D &= 5.6 & Re_D < 2300 \\ Nu_D &= 0.023 Re_D^{0.8} Pr^{0.4} & Re_D > 2300 \end{aligned}$$

Please click the advert

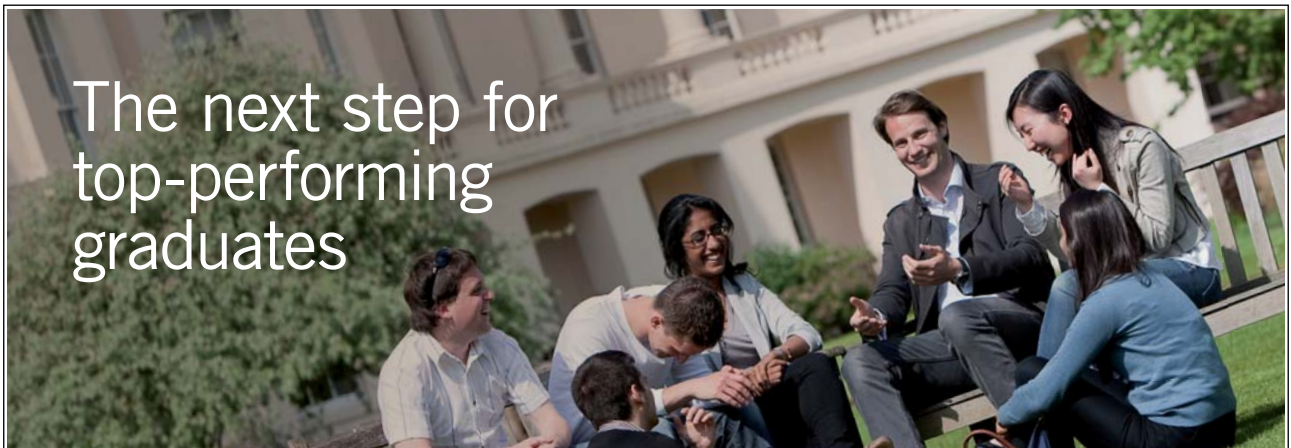

Masters in Management

Designed for high-achieving graduates across all disciplines, London Business School's Masters in Management provides specific and tangible foundations for a successful career in business.

This 12-month, full-time programme is a business qualification with impact. In 2010, our MiM employment rate was 95% within 3 months of graduation*; the majority of graduates choosing to work in consulting or financial services.

As well as a renowned qualification from a world-class business school, you also gain access to the School's network of more than 34,000 global alumni – a community that offers support and opportunities throughout your career.

For more information visit www.london.edu/mm, email mim@london.edu or give us a call on **+44 (0)20 7000 7573**.

* Figures taken from London Business School's Masters in Management 2010 employment report



Calculate the overall heat transfer coefficient.

Which is the controlling heat transfer coefficient?

If the heat exchanger is used to cool oil from 90°C to 55°C, using water at 10°C calculate the length of the tube for a parallel flow heat exchanger

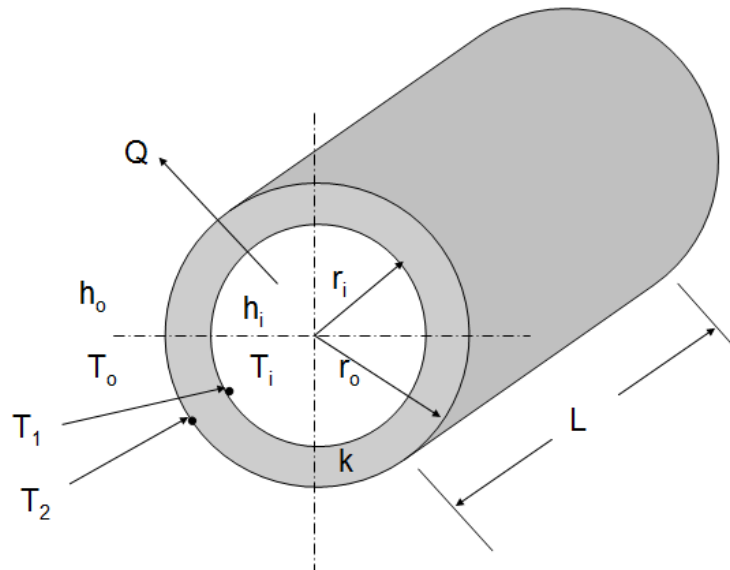

Solution:

a)

For the convection inside

$$Q = A_i h_i (T_i - T_1)$$

$$Q = 2\pi r_i L h_i (T_i - T_1) \quad (1)$$

For the convection outside

$$Q = A_o h_o (T_o - T_1)$$

$$Q = 2\pi r_o L h_o (T_o - T_1) \quad (2)$$

For conduction through the pipe material

$$Q = -2\pi r k \frac{dT}{dr}$$

$$dT = -\left(\frac{Q}{2\pi r L}\right) \frac{dr}{r} \quad (3)$$

Integrating between 1 and 2:

$$T_2 - T_1 = \left(\frac{Q}{2\pi r L}\right) \ln\left(\frac{r_o}{r_i}\right) \quad (4)$$

From 1 and 2

$$T_i - T_1 = \left(\frac{Q}{2\pi r_i L h_i}\right) \quad (5)$$

$$T_2 - T_o = \left(\frac{Q}{2\pi r_o L h_o}\right) \quad (6)$$

Adding 4, 5 and 6

$$T_i - T_o = \frac{Q}{2\pi L} \left(\frac{\ln(r_o/r_i)}{k} + \frac{1}{h_i r_i} + \frac{1}{h_o r_o} \right)$$

Rearranging

$$\frac{Q}{2\pi L r_o} = \frac{T_i - T_o}{\left(\frac{r_o}{k} \ln\left(\frac{r_o}{r_i}\right) + \frac{r_o}{h_i r_i} + \frac{1}{h_o} \right)} = U_o (T_i - T_o)$$

Therefore, overall heat transfer coefficient is

$$U_o = \left(\frac{r_o}{k} \ln\left(\frac{r_o}{r_i}\right) + \frac{r_o}{h_i r_i} + \frac{1}{h_o} \right)^{-1}$$

b)

i) To calculate the overall heat transfer coefficient, we need to evaluate the convection heat transfer coefficient both inside and outside.

$$\text{Re} = \frac{\rho V_m D_h}{\mu}$$

For water:

$$V_m = \frac{\dot{m}}{\rho A}, \quad A = \frac{\pi D^2}{4}$$

$$\text{Re} = \frac{4\dot{m}}{\pi D \mu} = \frac{4 \times 0.25}{\pi \times 0.05 \times 725 \times 10^{-6}} = 8781$$

$$\text{Pr} = \frac{\mu C_p}{k} = \frac{725 \times 10^{-6} \times 4178}{0.625} = 4.85$$

$\text{Re} > 2300$ (turbulent flow)

$$\text{Therefore: } Nu_D = 0.023 \text{Re}_D^{0.8} \text{Pr}^{0.4} = 0.023 \times 8781^{0.8} \times 4.85^{0.4} = 62$$

Please click the advert

Excellent Economics and Business programmes at:



**university of
 groningen**





**“The perfect start
 of a successful,
 international career.”**

CLICK HERE
 to discover why both socially
 and academically the University
 of Groningen is one of the best
 places for a student to be

www.rug.nl/feb/education

$$\text{From which: } h_i = \frac{Nu_D k}{D} = \frac{62 \times 0.625}{0.05} = 775 \text{ W/m}^2 \text{ K}$$

For oil:

$$D_h = \frac{4 \text{ Area}}{\text{Perimeter}} = \frac{4\pi(r_b^2 - r_a^2)}{2\pi(r_b + r_a)} = 2(r_b - r_a) = 2(0.045 - 0.025) = 0.034 \text{ m}$$

$$Re = \frac{\rho V_m D_h}{\mu} = \frac{2\dot{m}(r_b - r_a)}{\pi(r_b^2 - r_a^2)\mu} = \frac{2\dot{m}}{\pi(r_b + r_a)\mu} = \frac{2 \times 0.12}{\pi \times (0.045 + 0.028) \times 3.25 \times 10^{-2}} = 33$$

$Re < 2300$ (Laminar flow)

Therefore: $Nu_D = 5.6$

$$h_o = \frac{Nu_D k}{D_h} = \frac{5.6 \times 0.138}{0.034} = 22.7 \text{ W/m}^2 \text{ K}$$

$$U_o = \left(\frac{0.028}{16} \ln\left(\frac{28}{25}\right) + \frac{0.028}{725 \times 0.025} + \frac{1}{22.7} \right)^{-1} = 21.84 \text{ W/m}^2 \text{ K}$$

ii) The controlling heat transfer coefficient is that for oil, h_o because it is the lower one. Changes in h_o will cause similar changes in the overall heat transfer coefficient while changes in h_i will cause little changes. You can check that by doubling one of them at a time and keep the other fixed and check the effect on the overall heat transfer coefficient.

iii) $T_{hi} = 90^\circ\text{C}$, $T_{ci} = 10^\circ\text{C}$, $T_{ho} = 55^\circ\text{C}$

T_{co} is unknown. This can be computed from an energy balance

For the oil side:

$$Q = \dot{m}_h C_{ph} (T_{hi} - T_{ho}) = 0.12 \times 2131(90 - 35) = 8950 \text{ W}$$

$$Q = \dot{m}_c C_{pc} (T_{co} - T_{ci}) = 0.25 \times 4178(T_{co} - 10) = 8950 \text{ W}$$

Therefore $T_{co} = 18.56^\circ\text{C}$

Evaluate LMTD

$$\Delta T_1 = 90 - 10 = 80^\circ\text{C}$$

$$\Delta T_2 = 55 - 18.56 = 36.44^\circ\text{C}$$

$$\Delta T_{lm} = \frac{\Delta T_2 - \Delta T_1}{\ln(\Delta T_2 / \Delta T_1)} = \frac{36.44 - 80}{\ln(36.44 / 80)} = 56.1^\circ\text{C}$$

$$Q = UA\Delta T_{lm} = U_o \times 2\pi r_o L \Delta T_{lm}$$

$$L = \frac{Q}{U_o \times 2\pi r_o \Delta T_{lm}} = \frac{8950}{21.84 \times 2\pi \times 0.028 \times 56.1} = 41.5\text{m}$$

Example 5.4

Figure (a) below shows a cross-sectional view through part of a heat exchanger where cold air is heated by hot exhaust gases. Figure (b) shows a schematic view of the complete heat exchanger which has a total of 50 channels for the hot exhaust gas and 50 channels for the cold air. The width of the heat exchanger is 0.3m

Using the information tabulated below, together with the appropriate heat transfer correlations, determine:

- i. the hydraulic diameter for each passage;
- ii. the appropriate Reynolds number;
- iii. the overall heat transfer coefficient;
- iv. the outlet temperature of the cold air;
- v. and the length L

Use the following relations:

Using the relations:

$$Nu_D = 4.6 \quad Re_D < 2300$$

$$Nu_D = 0.023 Re_D^{0.8} Pr^{1/3} \quad Re_D > 2300$$

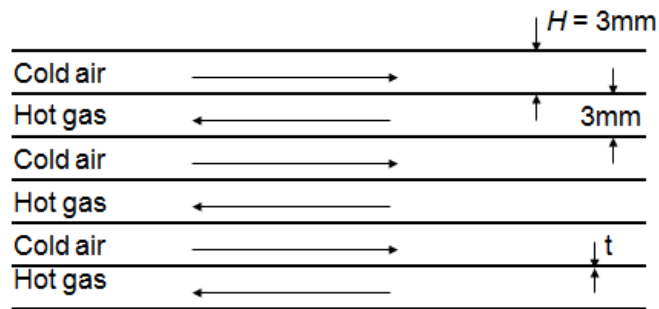

(a) Cross sectional view through part of the Heat Exchanger

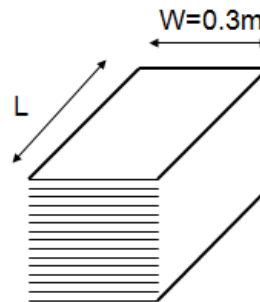

(b) Schematic diagram of the complete heat exchanger

Data for example 4.4

Hot exhaust inlet temperature	100°C
Hot exhaust outlet temperature	70°C
Cold air inlet temperature	30°C
Hot exhaust total mass flow	0.1 kg/s
Cold air total mass flow	0.1 kg/s
Density for exhaust and cold air	1 kg/m ³
Dynamic viscosity, exhaust and cold air	1.8x10 ⁻⁵ kg/m s
Thermal conductivity, exhaust and cold air	0.02 W/m K
Specific heat capacity, exhaust and cold air	1 kJ/kg K
Heat exchanger wall thickness	0.5 mm
Heat Exchanger wall thermal conductivity	180 W/m K
Hot exhaust side fouling resistance	0.01 K m ² /W
Cold air side fouling resistance	0.002 K m ² /W

Solution:

$$Re = \frac{\rho V L}{\mu}$$

$$L = D_h \quad (\text{Hydraulic diameter})$$

$$D_h = \frac{4 \times \text{cross sectional area}}{\text{perimeter}} = \frac{4 \times w \times H}{2(w + H)} = \frac{4 \times 0.003 \times 0.3}{2(0.003 + 0.3)} = 5.94 \text{ mm}$$

For a single passage:

$$V = \frac{(\dot{m}/50)}{(H \times w)\rho} = \frac{0.1/50}{(0.003 \times 0.3) \times 1} = 2.22 \text{ m/s}$$

$$\text{Re} = \frac{1 \times 2.22 \times 5.94 \times 10^{-3}}{1.8 \times 10^{-5}} = 733$$

$\text{Re} < 2300$ (laminar flow)

$$\text{Nu}_D = 4.6$$

$$h = \frac{\text{Nu}_D k}{D_h} = \frac{4.6 \times 0.02}{5.98 \times 10^{-3}} = 15.5 \text{ W/m}^2 \text{K}$$

Please click the advert

Teach with the Best. Learn with the Best.

Agilent offers a wide variety of affordable, industry-leading electronic test equipment as well as knowledge-rich, on-line resources—for professors and students.

We have 100's of comprehensive web-based teaching tools, lab experiments, application notes, brochures, DVDs/CDs, posters, and more.



© Agilent Technologies, Inc. 2012

u.s. 1-800-829-4444 canada: 1-877-894-4414

Anticipate — Accelerate — Achieve



Agilent Technologies

Since the thermal properties are the same and the mass flow rate is the same then the hot stream and cold stream heat transfer coefficients are also the same.

$$U = \left[\frac{1}{h_h} + R_{f,h} + \frac{t}{k} + \frac{1}{h_c} + R_{f,c} \right]^{-1} = \left[\frac{1}{15.5} + 0.01 + \frac{0.5 \times 10^{-3}}{180} + \frac{1}{15.5} + 0.002 \right]^{-1}$$

$$= 7.1 \text{ W / m}^2 \text{ K}$$

Note that if the third term in the brackets that includes the resistance through the metal is neglected, it will not affect the overall heat transfer coefficient because of the relatively very small thermal resistance.

$$Q = \dot{m}C_p (T_{h,i} - T_{h,o}) = \dot{m}C_p (T_{c,i} - T_{c,o})$$

$$T_{c,o} = T_{c,i} + (T_{h,i} - T_{h,o}) = 30 + (100 - 70) = 60^\circ \text{ C}$$

Also

$$Q = UA\Delta T_{lm}$$

T_{lm} is constant in a balanced flow heat exchanger

$$T_{lm} = 100 - 60 = 70 - 30 = 40^\circ \text{ C}$$

$$Q = \dot{m}C_p (T_{h,i} - T_{h,o}) = \frac{0.1}{50} \times 1000(100 - 70) = 60 \text{ w / passage}$$

Area of passage:

$$A = \frac{Q}{U\Delta T_{lm}} = \frac{60}{7.1 \times 40} = 0.211 \text{ m}^2$$

And since: $A = w \times L$

$$L = \frac{0.211}{0.3} = 0.704 \text{ m}$$