

Ernő Keszei

Chemical Thermodynamics

An Introduction

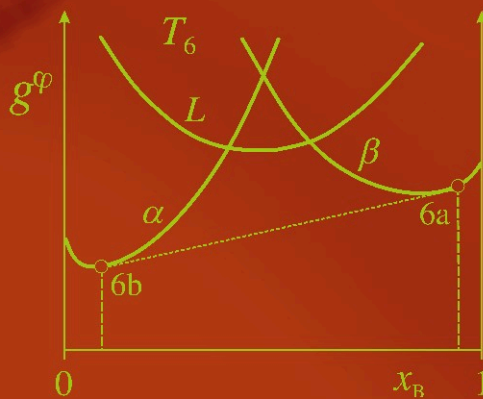

Chemical Thermodynamics

Ernő Keszei

Chemical Thermodynamics

An Introduction

 Springer

Dr. Ernő Keszei
Dept. Physical Chemistry
Lab. Chemical Kinetics
Eötvös Loránd University (ELTE)
Budapest, Hungary
keszei@chem.elte.hu

ISBN 978-3-642-19863-2 e-ISBN 978-3-642-19864-9
DOI 10.1007/978-3-642-19864-9
Springer Heidelberg Dordrecht London New York

Library of Congress Control Number: 2011934025

© Springer-Verlag Berlin Heidelberg 2012

This work is subject to copyright. All rights are reserved, whether the whole or part of the material is concerned, specifically the rights of translation, reprinting, reuse of illustrations, recitation, broadcasting, reproduction on microfilm or in any other way, and storage in data banks. Duplication of this publication or parts thereof is permitted only under the provisions of the German Copyright Law of September 9, 1965, in its current version, and permission for use must always be obtained from Springer. Violations are liable to prosecution under the German Copyright Law.

The use of general descriptive names, registered names, trademarks, etc. in this publication does not imply, even in the absence of a specific statement, that such names are exempt from the relevant protective laws and regulations and therefore free for general use.

Printed on acid-free paper

Springer is part of Springer Science+Business Media (www.springer.com)

Preface

According to an anecdote, the German physicist Arnold Sommerfeld said the following in the 1940s: “Thermodynamics is a funny subject. The first time you go through it, you don’t understand it at all. The second time you go through it, you think you understand it, except for one or two small points. The third time you go through it, you know you don’t understand it, but by that time you are so used to it, it doesn’t bother you any more.”

Things have changed much since then. University education has become available for a large number of students, and the Bologna process has led to a three-tier system also in the European Higher Education Area. As a result, most of the students of natural sciences or engineering do not have the opportunity any more to study subjects such as thermodynamics over and over again in order to gain deeper knowledge. Fortunately enough, in the second half of the twentieth century a new approach for teaching the foundations of thermodynamics emerged. This postulatory approach does not lead the student through a tedious historical development of the subject, but rather introduces thermodynamics by stating four concise postulates. These postulates facilitate the understanding of the subject by developing an abstract mathematical foundation from the beginning. This however rewards the student with an easy understanding of the subject, and the postulates are directly applicable to the solving of actual thermodynamic problems.

This book follows the postulatory approach used by Herbert B. Callen in a textbook first published in 1960. The basics of thermodynamics are described as briefly as possible whilst ensuring that students with a minimal skill of calculus can also understand the principles, by explaining all mathematical manipulations in enough detail. Subsequent chapters concerning chemical applications always refer to a solid mathematical basis derived from the postulates. The concise and easy-to-follow structure has been maintained – also in the chapters on applications for chemically important topics.

Though the text has been written primarily for undergraduate students in chemistry, I also kept in mind the needs of students studying physics, material sciences and biochemistry, who can also find a detailed introduction to the chemical aspects of thermodynamics concerning multi-component systems useful. The book has been intended to cover a considerably wide range of topics, enough

for a chemistry major course. However, some sections can be considered as optional and may be omitted even during a standard physical chemistry course. Examples are the fundamental equation of the ideal van der Waals fluid (Sect. 2.2.6), the equations of state of real gases, fluids and solids (Sect. 4.5), practical usage of engines and refrigerators (Sect. 5.4), or multi-component phase diagrams (Sect. 7.7). These omitted parts however can also be useful as a reference for the student during further studies in more specific branches of physical chemistry. The material covered in the appendix serves mostly to provide technical help in calculus, but it also contains a treatise of the “classical” laws of thermodynamics. It is important to be familiar with this aspect of thermodynamics to understand classical texts and applications that make reference to these laws. As this material is not necessary to understand postulatory thermodynamics, it is best left in the appendix. However, it is highly advisable to include it in the course material. Though the chapter on statistical thermodynamics could be skipped without any consequence to understanding the rest of the book, it is also advised to include it in a standard course. Quantum chemistry along with statistical thermodynamics is essential to help the student develop a solid knowledge of chemistry at the molecular level, which is necessary to understand chemistry in the twenty-first century.

This material is a result of 4 years of teaching thermodynamics as part of the new undergraduate chemistry curriculum introduced as the first cycle of the three-tier Bologna system. It has been continually improved through experience gained from teaching students in subsequent semesters. A number of students who studied from the first versions contributed to this improvement. I would like to mention two of them here; Tibor Nagy who helped to rectify the introductory chapters, and Soma Vesztergom who helped a great deal in creating end-of-chapter problems. I am also indebted to colleagues who helped to improve the text. Thanks are due to Professor József Cserti and Tamás Tél for a critical reading of the introductory chapters and phase transitions. Professor Róbert Schiller helped to keep the chapter on the extension of interactions concise but informative.

Since the time I first presented the text to Springer, I have experienced the constant support of Ms. Elizabeth Hawkins, editor in chemistry. I would like to thank her for her patience and cooperation which helped me to produce the manuscript on time and in a suitable format for printing.

Budapest, Hungary

Ernő Keszei

Contents

1 Introduction	1
Further Reading	2
2 Postulates of Thermodynamics	3
2.1 Thermodynamic Systems: Postulate 1	4
2.1.1 Constrained Systems and the Measurability of Energy via Mechanical Work	6
2.2 The Conditions of Equilibrium: Postulates 2, 3 and 4	8
2.2.1 Properties of the Entropy Function	10
2.2.2 Properties of the Differential Fundamental Equation	13
2.2.3 The Scale of Entropy and Temperature	15
2.2.4 Euler Relation, Gibbs–Duhem Equation and Equations of State	17
2.2.5 The Fundamental Equation of an Ideal Gas	18
2.2.6 The Fundamental Equation of an Ideal van der Waals Fluid	22
Further Reading	28
3 Thermodynamic Equilibrium in Isolated and Isentropic Systems	29
3.1 Thermal Equilibrium	32
3.2 Thermal and Mechanical Equilibrium	36
3.3 Thermal and Chemical Equilibrium	37
Further Reading	41
4 Thermodynamic Equilibrium in Systems with Other Constraints	43
4.1 Equilibrium in Constant Pressure Systems: The Enthalpy Function	44
4.2 Equilibrium in Constant Temperature and Constant Volume Systems: The Free Energy Function	46

4.3	Equilibrium in Constant Temperature and Constant Pressure Systems: The Gibbs Potential	48
4.4	Summary of the Equilibrium Conditions: Properties of the Energy-like Potential Functions	50
4.4.1	Calculation of Heat and Work from Thermodynamic Potential Functions	52
4.4.2	Calculation of Entropy and Energy-like Functions from Measurable Quantities	53
4.4.3	Calculation of Thermodynamic Quantities from the Fundamental Equation	57
4.5	Equations of State of Real Gases, Fluids and Solids	58
4.5.1	Chemical Potential and Fugacity of a Real Gas	64
	Further Reading	68
5	Thermodynamic Processes and Engines	69
5.1	Quasistatic, Reversible and Irreversible Processes	69
5.2	Heat Engines: The Carnot Cycle and the Carnot Engine	72
5.3	Refrigerators and Heat Pumps: The Carnot Refrigerating and Heat-Pump Cycle	75
5.4	Heat Engines and Refrigerators Used in Practice	77
5.4.1	Heat Engines Based on the Rankine Cycle	77
5.4.2	Refrigerators and Heat Pumps Based on the Rankine Cycle	79
5.4.3	Isenthalpic Processes: The Joule–Thompson Effect	80
	Further Reading	85
6	Thermodynamics of Mixtures (Multicomponent Systems)	87
6.1	Partial Molar Quantities	87
6.1.1	Chemical Potential as a Partial Molar Quantity	89
6.1.2	Determination of Partial Molar Quantities from Experimental Data	90
6.2	Thermodynamics of Ideal Mixtures	93
6.2.1	Ideal Gas Mixtures	93
6.2.2	Properties of Ideal Mixtures	95
6.2.3	Alternative Reference States	98
6.2.4	Activity and Standard State	101
6.3	Thermodynamics of Real Mixtures	103
6.3.1	Mixtures of Real Gases	103
6.3.2	The Chemical Potential in Terms of Mole Fractions	106
6.3.3	The Chemical Potential in Terms of Solute Concentration ...	108
6.3.4	Activity and Standard State: An Overview	109
6.3.5	Thermodynamic Properties of a Real Mixture	115
6.4	Ideal Solutions and Ideal Dilute Solutions	118
	Further Reading	122

7 Phase Equilibria	125
7.1 Stability of Phases	127
7.2 Phase Equilibria of Pure Substances	129
7.2.1 Phase Diagrams of Pure Substances	135
7.2.2 Calculation of the Quantity of Coexisting phases: the Lever Rule	139
7.2.3 Calculation of Equilibrium Temperature and Pressure; the Clausius–Clapeyron Equation	141
7.2.4 First-Order and Second-Order Phase Transitions	144
7.3 Liquid–Vapor Equilibrium of Ideal Binary Mixtures	147
7.4 Liquid–Vapor Equilibrium of Real Binary Mixtures	154
7.5 Solid–Liquid Equilibrium of Ideal Binary Mixtures	158
7.6 Equilibrium of Partially Miscible Binary Mixtures	159
7.6.1 Liquid–Liquid Phase Diagrams	161
7.6.2 Solid–Liquid Phase Diagrams	163
7.6.3 Colligative Properties: Equilibrium of a Binary Mixture Phase and a Pure Phase Containing One of the Mixture Components	178
7.7 Phase Diagrams of Multicomponent Systems	185
7.8 Separation of Components Based on Different Phase Diagrams	190
Further Reading	200
8 Equilibria of Chemical Reactions	201
8.1 Condition of a Chemical Equilibrium at Constant Temperature and Pressure	202
8.1.1 Relation of the Equilibrium Constant and the Stoichiometric Equation	205
8.1.2 Affinity: The Driving Force of Chemical Reactions	206
8.2 The Equilibrium Constant in Terms of Different Activities	211
8.2.1 Heterogeneous Reaction Equilibria of Immiscible Components	214
8.3 Calculation of the Equilibrium Constant from Thermodynamic Data	218
8.4 Temperature and Pressure Dependence of the Equilibrium Constant	221
8.4.1 The Le Châtelier–Braun Principle	223
Further Reading	226
9 Extension of Thermodynamics for Additional Interactions (Non-Simple Systems)	227
9.1 Thermodynamics of Interfaces: Two-Dimensional Equations of State	231
9.1.1 Thermodynamic Properties of Curved Surfaces	234

9.2 Thermodynamic Description of Systems Containing Electrically Charged Particles	241
9.2.1 Thermodynamic Consequences of the Electroneutrality Principle: The Chemical Potential of Electrolytes and the Mean Activity Coefficient	244
9.2.2 Chemical Potential of Ions in an Electric Field: The Electrochemical Potential	251
9.2.3 Heterogeneous Electrochemical Equilibria: The Galvanic Cell	253
9.2.4 Electrodes and Electrode Potentials	259
Further Reading	264
10 Elements of Equilibrium Statistical Thermodynamics	265
10.1 The Microcanonical Ensemble	266
10.1.1 Statistical Thermodynamics of the Einstein Solid in Microcanonical Representation	269
10.1.2 Statistical Thermodynamics of a System of Two-State Molecules in Microcanonical Representation	272
10.2 The Canonical Ensemble	274
10.2.1 Calculation of the Canonical Partition Function from Molecular Data	280
10.2.2 Statistical Thermodynamics of the Einstein Solid and the System of Two-State Molecules in Canonical Representation	281
10.2.3 The Translational Partition Function. Statistical Thermodynamics of a Monatomic Ideal Gas	283
10.2.4 Calculation of the Rotational, Vibrational, and Electronic Partition Functions	287
10.2.5 Statistical Characterization of the Canonical Energy	291
10.2.6 The Equipartition Theorem	294
10.3 General Statistical Definition and Interpretation of Entropy	297
10.4 Calculation of the Chemical Equilibrium Constant from Canonical Partition Functions	300
Further Reading	306
11 Toward Equilibrium: Elements of Transport Phenomena	307
11.1 Transport Equations for Heat, Electricity, and Momentum	309
11.2 Equations for the Diffusive Material Transport	311
11.2.1 Fick's First Law: The Flux of Diffusion	312
11.2.2 Fick's Second Law: The Rate of Change of the Concentration Profile	312
11.3 Principle Transport Processes and Coupled Processes	316
Further Reading	318

Appendix	319
A1 Useful Relations of Multivariate Calculus	319
A.1.1 Differentiation of Multivariate Functions	319
A.1.2 Differentiation of Composite Functions	322
A.1.3 Differentiation of Implicit Functions	323
A.1.4 Integration of Multivariate Functions	324
A.1.5 The Euler Equation for Homogeneous First-Order Functions	325
A2 Changing Extensive Variables to Intensive Ones: Legendre Transformation	326
A.2.1 Legendre Transformations	327
A.2.2 Legendre Transformation of the Entropy Function	329
A3 Classical Thermodynamics: The Laws	331
A.3.1 Zeroth Law and Temperature	332
A.3.2 First Law and Energy	334
A.3.3 Second Law and Entropy	336
A.3.4 Third Law and the Uniqueness of the Entropy Scale	341
Further Reading	341
Index	343

Chapter 1

Introduction

Physical chemistry deals with general properties common in different materials despite their chemical diversity. Properties referring to materials stored in a container – i.e., materials “at rest,” without temporal changes – have a special importance. These materials are told to be in an “equilibrium state” and are described by the science called *thermodynamics*. Equilibrium states can be very different depending on the circumstances; thus, one of the major aims of thermodynamics is to quantitatively characterize materials within different conditions and the changes accompanying their transition to a new state. The term “thermodynamics” has a historical origin. At the beginning of the nineteenth century, there was an attempt to understand the underlying principles of the efficiency of steam engines already in operation. The basic problem of the investigations was the transformation of heat into mechanical work. The Greek word *θερμη* [therme] means hotness (heat), while another Greek word, *δυναμις* [dynamis] means the ability to act (power). Putting the two words together expressed the basic direction of this research. (The branch of mechanics dealing with movements is also called dynamics, originating from the same Greek word. Based on this, some authors criticize the name thermodynamics and propose *thermostatics* instead, as the underlying Greek word (*στασις* [stasis] = state) refers more directly to equilibrium states. These critics are not really relevant since actual names of branches of science are arbitrary, having a historical origin.) The term “thermodynamics” survived, even though this science explains a lot more than the efficiency of heat engines.

There are other branches of physics dealing with the characterization of equilibria; mechanics with equilibria of mechanical interactions, electrostatics with that of electric interactions, magnetostatics with that of magnetic interactions, and the calculations of interaction energies. Thermodynamics includes all these interactions but includes in addition the influence on interaction energies of the state of “hotness” (or coldness) of matter. It will be clear from molecular (or statistical) thermodynamics that the temperature-dependent energy involves changes in the molecular modes hidden at the macroscopic level. These molecular modes cannot be observed directly by measuring macroscopic quantities only, but the consequences of their changes are accessible for macroscopic observations.

Thermodynamics differs basically from other branches of physics by considering this *thermal energy* and other *thermal properties*.

Chemical thermodynamics – in addition to what physicists and civil engineers usually learn as thermodynamics – deals with materials and properties where the chemical composition and its change are especially important. Quantitative relations concerning composition and its change are usually rather complicated. There is a special role of traditions and conventions established during the development of this science to describe the “chemical” aspects. This book – after a concise introduction to the principles of thermodynamics – concentrates on the thermodynamic description depending on the composition of equilibrium states and a detailed discussion of the underlying conventions. To establish the general principles is unavoidable before actual applications to chemically interesting systems, thus the first part of the book describes the very foundations of thermodynamics.

As mentioned before, the science of thermodynamics was developed by the interpretation of how steam engines, or in a wider sense and after later inventions, heat engines in general operate. This is the reason why its traditional treatment is based on conclusions drawn from the operation of those engines. This treatment is quite complicated and is not best suited to develop the principles underlying chemical applications. There is another possibility to set the foundations of a science, as it is common practice, e.g., in geometry, number theory, probability theory, or in physical sciences like mechanics, electrodynamics, and quantum mechanics. This is the *postulatory* foundation when a few *postulates* (or *axioms*) are formulated, from which all theorems can be proved or all important relations derived. Already at the end of the nineteenth century, the American physicist Josiah Willard Gibbs proposed mathematically sound foundations of thermodynamics, but a genuine system of postulates has only been formulated in the middle of the twentieth century, mainly due to László Tisza, an American physicist of Hungarian origin. The treatment of this book concerning the foundations of thermodynamics is closely related to the frequently referred textbook by Herbert B. Callen (a former student of Tisza) published 1960 with the title “Thermodynamics,” as well as its second edition published 1985. In addition to this – concerning especially statistical thermodynamics and chemical applications – a number of other textbooks have been used as resources, which are listed at the end of the chapters.

Further Reading

Callen HB (1985) Thermodynamics and an introduction to thermostatistics, 2nd edn. Wiley, New York

Chapter 2

Postulates of Thermodynamics

Thermodynamics is a general theory; it deals with the properties of all kinds of matter where the behavior of a large number of *microscopic* particles (such as molecules, atoms, ions, etc.) determines the *macroscopic* properties. It is stated sometimes that this branch of science deals with the transformation of the *thermal energy* hidden in the internal structure and modes of movements of the enormously large number of particles that build up macroscopic bodies, into other forms of energy. As the microscopic structure of matter, the modes of movements and the interactions of particles have further consequences than simply determining the energy of a macroscopic body; thermodynamics has a more general relevance to describe the behavior of matter.

The number of particles in a macroscopic piece of matter is in the order of magnitude of the Avogadro constant ($6.022\,141\,79 \times 10^{23}$ /mol). Obviously, there is no question of describing the movement of individual particles; we should content ourselves with the description of the average behavior of this large population. Based on our actual knowledge on probability theory, we would naturally use a statistical description of the large population to get the average properties. By comparing the calculated averages – more precisely, the *expected values* – with macroscopic measurements, we could determine properties that “survive” averaging and manifest at the macroscopic level. There are not many such properties; thus, this treatment of the ensemble of particles would lead to practically useful results. This probabilistic approach is called *statistical thermodynamics* or, in a broader sense, *statistical physics*.

However, as it has been mentioned before (and is described in details in Appendix 3), thermodynamics had been developed in the middle of the nineteenth century while attempting to theoretically solve the problem of efficiency of transforming heat into mechanical work. The “atomistic” theory of matter was of very little interest in those days, thus thermodynamics developed only by inspection and thorough investigation of macroscopic properties. This is reflected in the term *phenomenological thermodynamics*, which is related to the Latin word of Greek origin *phenomenon* (an observable event). This “classical” thermodynamics used terms relevant to heat engines to formulate a few “laws” from which relations

useful to solve problems were derived. After more than half a century later, *postulational thermodynamics* has been developed where the basic principles are formulated not in terms of heat engines but useful relations of general validity ready to use for solving problems. In this chapter, these postulates are introduced and discussed. As it is also important to know the treatment based on the classical “laws” partly to understand scientists who learnt thermodynamics this way, partly to understand traditional thermodynamic tables and articles, classical laws are discussed in details in the Appendix.

2.1 Thermodynamic Systems: Postulate 1

Objects studied by thermodynamics are called *thermodynamic systems*. These are not simply “the part of the world under consideration”; rather physical bodies having a special property: they are in *equilibrium*. It is not straightforward to determine if a piece of matter is in equilibrium. Putting this piece of matter into a “container,” it would come to rest sooner or later and its properties would not depend on time and typically not on the spatial position either. However, this temporal and spatial independence could allow for stationary flow inside the container, which cannot be considered as rest. Another approach could be to assure that, besides keeping the piece of matter within the container, no other external influence is allowed. Again, we cannot be quite sure that this system would be in equilibrium. A better formulation was that thermodynamics is valid for those bodies at rest, for which the predictions based on thermodynamic relations coincide with reality (i.e., with experimental results). This is an *a posteriori* definition; the validity of thermodynamic description can be verified after its actual application. However peculiar, this is common practice in science. We can often encounter statements that, to describe a phenomenon or solve a problem, classical mechanics is valid (or not valid). As we will see further in the book, thermodynamics offers a valid description for an astonishingly wide variety of matter and phenomena.

In the light of the above considerations, it is not surprising that the first postulate of thermodynamics declares the existence of equilibrium and states its important properties. Before announcing the postulate, let us limit the variety of the physical bodies under consideration for practical reasons. Let us restrict our attention to *simple systems*, defined as follows. *Simple systems* are pieces of matter that are macroscopically *homogeneous and isotropic*, electrically *uncharged*, chemically *inert*, large enough so that *surface effects can be neglected*, and they are *not acted on by electric, magnetic, or gravitational fields*. These restrictions largely facilitate thermodynamic description without limitations to apply it later to more complicated systems where these limitations are not obeyed. We can conclude from the above description that the postulates will be formulated for physical bodies that are homogeneous and isotropic, and their only possibility to interact with the surroundings is mechanical work exerted by volume change, plus thermal and chemical interactions. (It is important to note here that chemical interactions are still possible

even for chemically inert systems, for we consider as chemical interaction the transport of chemical species from or into the system.) Now we are in a position to formulate *Postulate 1* of thermodynamics:

There exist particular states (called equilibrium states) of simple systems that, macroscopically, are characterized completely by the internal energy U , the volume V , and the amounts of the K chemical components n_1, n_2, \dots, n_K .

An important consequence of this postulate is that the equilibrium state of simple systems consisting of K chemical components can completely be described by $K + 2$ data. In other words, a simple system has $K + 2$ *degrees of freedom*. This means that if we know the amounts of substances of the K components – the *composition vector* $\mathbf{n} = (n_1, n_2, \dots, n_K)$ – along with the internal energy¹ U and the volume V , we know everything from a thermodynamic point of view of the simple system; any other (thermodynamic) quantities are well defined as functions of the variables $U, V, n_1, n_2, \dots, n_K$. This is the reason to call these variables as *state variables* or *thermodynamic coordinates*. Functions that are completely determined by these variables are called *state functions*. We shall introduce several state functions later in the book.

Another important consequence is that the state of a thermodynamic system cannot depend on the past history of the system. There exist materials (e.g., glass and steel) which do not obey this condition; their properties depend on the cooling rate, heat treatment, etc., during their manufacturing procedure, not only on the actual values of $U, V, n_1, n_2, \dots, n_K$. If such systems are characterized on the basis of thermodynamic formalism, predicted results are usually different from experimental observations. This failure of the theoretical description can be used *a posteriori* to detect nonequilibrium states.

It is worth considering another aspect of the thermodynamic equilibrium. From the properties of mechanical equilibria we know that the equilibrium state can be different depending on different conditions. The condition of mechanical equilibrium is the minimum of energy. A rigid body at rest on a desktop shelf is in mechanical equilibrium. The same body placed lower on the top of the desk is in a “more stable” equilibrium state. We can place it even lower, say, on the floor, where its stability is further increased. This lowering could be continued down to the deepest point achievable below the earth’s surface. If the body has an elongated shape, it has at least two different equilibrium states already on the desktop; a standing and a lying position. Obviously, the lying position has lower energy; thus,

¹The term *internal energy* refers to the energy content of the thermodynamic system which does not include either the kinetic energy or the potential energy acting on the whole system. In other words, it is the energy of the system if the entire system as a whole has zero velocity, zero angular momentum and there is no field acting on the system as a whole. It can be considered as the sum of the energy of the particles in their microscopic modes of motion without the above mentioned contributions. However, as the scale of the energy is not absolute (we can determine it only up to an additive constant), we can restrict the microscopic modes to contribute to the internal energy. Nuclear energy is usually not included in the summation to get the internal energy as it does not change in typical everyday applications of thermodynamics.

it is more stable than the standing position. Similarly, we can consider thermodynamic systems also to be in a less stable or more stable state. If the particles of a thermodynamic system can “explore” all the possible microstates, the system is in its most stable (macroscopic) state. If the particles are hindered to access all the possible microstates, the system can be “stuck” in a less stable state we call *metastable* state. These metastable states are more common in the solid state than in a gas or a liquid, where particles do not “freeze” into the solid structure. However, chemical reactions that do not occur (as for example in a mixture of H_2 and O_2 at room temperature) result in metastable equilibria even in a gas or a liquid. Until the conditions leading to the metastable state would persist, thermodynamic description can be applied; thus, Postulate 1 is also valid. It is worth noting that metastable equilibria are much more frequent within earthly conditions than stable equilibria. Thinking over that stable equilibrium on Earth would necessitate winds to stand still, waters to cease rolling, all chemical and nuclear reactions to run to completion, etc., we can easily see that the majority of earthly equilibria should be metastable. To maintain a metastable equilibrium, different *constraints* play a crucial role. We shall explore some of these constraints in the next section.

2.1.1 Constrained Systems and the Measurability of Energy via Mechanical Work

As it was mentioned before, thermodynamic systems are typically enclosed in a container. This container can also be a common everyday device. Wine is a thermodynamic body having several pleasant properties which we can keep in a barrel, a bottle, a glass, along with several other containers. In case of solid bodies, the container is usually only virtual, not a physical device. Despite this, a solid body lying on the tabletop is within well defined constraints. It is at constant pressure (equal to the pressure of the surrounding air), or at constant temperature if the temperature of the tabletop and the air are equal and would not change. If the volume of the body does not change, the constraint of constant volume also applies. This is equivalent to a real container whose walls would ensure constant temperature, pressure and volume. In thermodynamics, walls having the properties shown in Table 2.1 are usually distinguished. Systems enclosed within walls of given properties are usually named after the according constraints.

To solve thermodynamic problems, the choice of appropriate container properties could help a lot. As an example, let us consider (simple) adiabatic systems where changes of the internal energy U can easily be measured and calculated. Let us consider a simple system having internal energy U_1 , volume V_1 , and composition n_1 in a closed adiabatic enclosure having flexible walls. (As an example, we can think of a gas inside a thermally insulating cylinder with a freely moving piston.) These constraints only allow for volume change as interaction between the system and the surroundings.

Table 2.1 Container types and enclosed systems

Container wall	Enclosed system
Completely isolating	Isolated
Diathermal ^a	Diabatic ^a
Thermally insulating	Adiabatic ^a
Rigid	Rigid
Flexible	Flexible
Permeable (to chemical components)	Open
Impermeable	Closed
Semi-permeable	Partly closed (partly open)

^aThe words *diabatic*, *adiabatic* and *diathermal* have Greek origin. The Greek noun *διαβάσις* [diabasis] designates a pass through, e.g., a river, and its derivative *διαβατικός* [diabatikos] means the possibility that something can be passed through. Adding the prefix *α-* expressing negation, we get the adjective *αδιαβατικός* [adiabatikos] meaning non-passability. In thermodynamic context, diabatic means the possibility for *heat* to cross the wall of the container, while adiabatic has the opposite meaning, i.e., the impossibility for heat to cross. In a similar manner, *diathermal* can be derived from the Greek word *θερμη* [therme] = heat, thus it refers more directly to a heat-conducting wall. (Note that the terms diabatic and adiabatic are also used in quantum mechanics with the difference that they do not refer to heat but for a particle (e.g., electron) that can (or cannot) pass from one potential surface onto the other.) Avoid using the double-negation form nonadiabatic instead the correct form diabatic

It is easy to calculate the work associated to the volume change. Mechanical work during linear displacement can be calculated by integrating the force F parallel to the direction of the movement with respect to the displacement s :

$$W = \int_{s_1}^{s_2} F \, ds. \quad (2.1)$$

The work during volume change can be calculated considering displacements in the three independent directions of the three-dimensional space. As a result we should replace in (2.1) the one-dimensional force F by the three-dimensional *pressure* P , and the one-dimensional displacement s by the three-dimensional *volume* V . This way we get the so called *volume work*, referred to hereinafter simply as *mechanical work*. (Other types of mechanical work are related to, e.g., a rotating shaft, a lifted weight, or jet propulsion; but we will not consider them in this book.) Calculation of the volume work can easily be formulated thinking in terms of the displacement of a piston in a cylinder. The force F in (2.1) acting on the piston of surface A is PA , which is multiplied by the infinitesimal displacement ds . The product Ads yields the infinitesimal volume change dV , which should be multiplied by the pressure P to give the volume work:

$$W = - \int_{V_1}^{V_2} P \, dV. \quad (2.2)$$

Changing the position of the piston, we can transform the system having internal energy U_1 , volume V_1 and composition n_1 into a system having internal energy U_2 , volume V_2 , and composition n_2 . (As the system is closed, its composition cannot

change but the work associated to the volume change can change the internal energy as well.) Being adiabatic, the internal energy of the system could have changed only as a result of the mechanical work. The minus sign in (2.2) is due to the fact that work done against the pressure (compression) increases the energy of the system, while in the opposite direction (expansion) it decreases the energy of the system.

Consequently, in a closed adiabatic system the following statement (expressing the conservation of energy) is valid:

$$\Delta_1^2 U = W_{\text{adiabatic}} = - \int_{V_1}^{V_2} P \, dV. \quad (2.3)$$

In this equation, $\Delta_1^2 U$ refers to the change of energy when changing the state of the system from the state (U_1, V_1, \mathbf{n}_1) to the state (U_2, V_2, \mathbf{n}_2) . (We know that, in this special case, $\mathbf{n}_1 = \mathbf{n}_2$) As we have seen, this energy change can easily be calculated for an adiabatic system. Let us change the state of the system by replacing the adiabatic wall by a diathermal wall. (We may do this by removing the heat insulator from the cylinder.) In this case, not only work but also heat can be exchanged with the surroundings during the change of the state. The work exchanged can be calculated again using (2.2). The heat exchanged can be calculated based on Postulate 1:

$$Q = \Delta_1^2 U - W. \quad (2.4)$$

Based on the above considerations we can conclude that the change in internal energy of thermodynamic systems is not only *determined* completely – as stated by Postulate 1 – but it can also be *measured* making use of the adiabatic enclosure. This statement can also be formulated in a general way saying that the change in internal energy (of a closed simple system) can be given as the sum of the work done on the system and the heat absorbed from the surroundings:

$$\Delta U = Q + W. \quad (2.5)$$

As already mentioned before, Postulate 1 thus expresses the conservation of energy including its change by heat transfer. It can also be seen from (2.5) that only *changes* in internal energy can be measured, not its absolute value. Similarly to mechanics, the absolute value of energy cannot be determined, thus its zero point is a matter of convention. We shall see later that this zero point will be given by fixing the scale of *enthalpy*, introduced in Sect. 8.3.

2.2 The Conditions of Equilibrium: Postulates 2, 3 and 4

Postulate 1 guarantees that the (equilibrium) state of a thermodynamic system is completely determined by fixing its relevant state variables (U, V, \mathbf{n}) . It would be useful to know how these variables would change when changing conditions

resulting in a new (equilibrium) state of the system. To specify this problem, let us consider a simple system consisting of two subsystems that we shall call a *composite system*. In addition to the walls of the entire composite system, the wall dividing it into two subsystems determines what consequences eventual changes will have on the system. As it will turn out, this arrangement provides a general insight into the basic problem of thermodynamics concerning the calculation of the properties of a new equilibrium state upon changes of conditions, and actual calculations can be traced back to it.

Before discussing the problem, let us explore an important property of the state variables U , V , and \mathbf{n} . To calculate the variables characterizing the entire composite system using the data $(U^\alpha, V^\alpha, \mathbf{n}^\alpha)$ and $(U^\beta, V^\beta, \mathbf{n}^\beta)$ of the constituent subsystems, we have to add the energies, volumes and the amounts of components of the subsystems. In mathematical terms, these variables are *additive* over the constituent subsystems. In thermodynamics, they are called *extensive variables*. When solving the problem of finding a new equilibrium state, we shall make use of this property and calculate U , V , n_1 , n_2 , \dots , n_K as sums of the corresponding variables of the subsystems α and β .

We can restrict ourselves to discuss the problem considering as example a closed cylinder inside which a piston divides the two subsystems (see Fig. 2.1).

The overall system (the cylinder) is rigid, impermeable and adiabatic; in one word, isolated. In the initial state, the piston is also rigid (i.e., its position is fixed in the cylinder), impermeable and adiabatic. Let $U^\alpha, V^\alpha, \mathbf{n}^\alpha$ and $U^\beta, V^\beta, \mathbf{n}^\beta$ denote the state variables of the subsystems in equilibrium within these conditions. This equilibrium can be changed in different ways. Releasing the fixing device of the piston (making the rigid wall flexible), it can move in one of the two possible directions which results in volume changes in both subsystems and, as a consequence, in a change of the internal energies U^α and U^β . Stripping the adiabatic coating from the fixed piston, heat can flow between the two systems, also changing the internal energies of the subsystems. Punching holes in the piston, a redistribution of chemical species can occur, resulting also in a change of the internal energy. Parts of the piston can also be changed for a semipermeable membrane allowing some chemical components to pass but not all of them. All of these changes result in

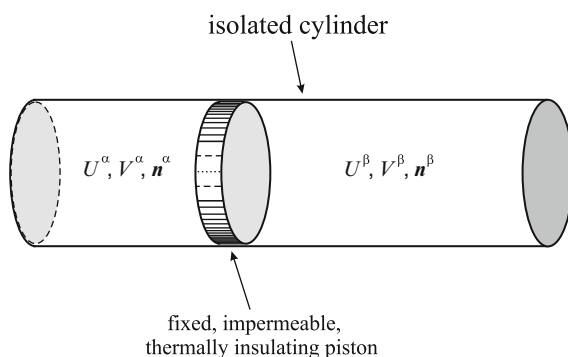

Fig. 2.1 Variables to describe a composite system consisting of two subsystems

changing U^α and U^β . However, as the overall system (the cylinder) is isolated, its energy cannot change during the changes described above.

From our studies in physics we might expect that an economical form of the equilibrium criterion would be in terms of an extremum principle. In mechanics it is the minimum of energy, which can be used in case of electric or magnetic interactions as well. It is easy to see that using the energy but multiplied by -1 would lead to the maximum as a criterion indicating equilibrium. The criterion of thermodynamic equilibrium can also be formulated using an extremum principle. This principle is formulated in *Postulate 2* of thermodynamics.

There exists a function (called the entropy and denoted by S) of the extensive parameters of any composite system, defined for all equilibrium states and having the following property: The values assumed by the extensive parameters in the absence of an internal constraint are those that maximize the entropy over the manifold of constrained equilibrium states.

2.2.1 Properties of the Entropy Function

Let us examine the meaning of Postulate 2 concerning the properties of the entropy function. Its first important property is that it is defined only for equilibrium states. If there is no equilibrium, there exists no entropy function. The maximum principle can be interpreted the following way. In the absence of a given constraint, there could be many states of the system imagined, all of which could be realized keeping the constraint. If, for example, we consider states that could be realized by moving the impermeable adiabatic piston, there are as many possibilities as different (fixed) positions of the piston. (The position of the piston is *in principle* a continuous variable, so it could be fixed in an infinity of positions. *In practice*, we can only realize finite displacements, but the number of these finite displacements is also very large.) At every position, the values of $U, V, n_1, n_2, \dots, n_K$ are unique, and they determine the unique value of the entropy function. Releasing the constraint (removing the fixing device of the piston), the equilibrium state will be the one from the manifold mentioned above which has the maximum of entropy.

Postulate 2 assigns valuable properties to the entropy function. If we know the form of this function and an initial set of the state variables in a given (equilibrium) state, we can calculate the state variables in any other state. Consequently, the entropy function contains all information of the system from a thermodynamic point of view. That's the reason that the equation

$$S = S(U, V, n_1, n_2, \dots, n_K) \quad (2.6)$$

is called a *fundamental equation*. It is worth to note that the actual form of the entropy function is different from one system to another; an entropy function of wider validity is rare to find. For practical systems (materials), there cannot be usually given an entropy function in a closed form. Instead, a table of the entropy as a function of different values of its variables is given for many systems.

Further properties of the entropy function are stated by two other postulates. *Postulate 3* states the following:

The entropy of a composite system is additive over the constituent subsystems. The entropy is continuous and differentiable and is a strictly increasing function of the internal energy.

Several properties of the entropy function follow from Postulate 3. Its *additivity* means that it is an *extensive property*. All the variables of the entropy function are also extensive. Therefore, if we have to increase a part of the system λ -fold to get the entire volume λV of the system, then its other variables (U, n_1, n_2, \dots, n_K) as well as the value of the entropy function will also increase λ -fold. Putting this in a mathematical form, we get

$$S(\lambda U, \lambda V, \lambda n_1, \lambda n_2, \dots, \lambda n_K) = \lambda S(U, V, n_1, n_2, \dots, n_K). \quad (2.7)$$

In mathematics, functions of this property are said to be *homogeneous first order functions* which have other special properties we shall make use of later on. There exists a particular value of λ which has special importance in chemical thermodynamics. Let us denote the sum of the amounts of components n_1, n_2, \dots, n_K constituting the system by n and call it the *total amount* of the system. Any extensive quantity divided by n will be called the respective *molar quantity* of the system. These properties will be denoted by the lower case Latin letters corresponding to the upper case symbols denoting the extensive quantity. An exception is the symbol of the amount of a component n_i which is already a lower case letter; its molar value is denoted by x_i and called the *mole fraction* of the i -th component:

$$x_i = \frac{n_i}{\sum_{j=1}^K n_j} = \frac{n_i}{n}. \quad (2.8)$$

Writing (2.7) using the factor $\lambda = 1/n$ we get the transformed function

$$S(U/n, V/n, n_1/n, n_2/n, \dots, n_k/n) = S(U, V, n_1, n_2, \dots, n_k)/n \quad (2.9)$$

that can be considered as the definition of $s(u, v, x_1, x_2, \dots, x_K)$, the *molar entropy*. However, its variables ($u, v, x_1, x_2, \dots, x_K$) are no more independent as the relation

$$\sum_{i=1}^K x_i = 1 \quad (2.10)$$

between the mole fractions x_i holds, following from the definition (2.8). Consequently, the number of degrees of freedom of the molar entropy function is less by one, i.e., only $K + 1$. This is in accordance with the fact that – knowing only the molar value of an extensive quantity – we do not know the extent of the system; it should be given additionally, using the missing degree of freedom. For this reason, molar quantities are not extensive, which is reflected by their name; they are called

intensive variables or *intensive quantities*. Coming back to the intensive entropy function; the equation specifying this function contains *all information* (except for the extent) of the thermodynamic system. Therefore, the equation

$$s = s(u, v, x_1, x_2, \dots, x_K) \quad (2.11)$$

is called the *entropy-based intensive fundamental equation*.

Applying (2.7) for functions whose value is a molar quantity, we get the result that they remain unchanged when multiplying each of their extensive variables by a factor λ :

$$s(\lambda U, \lambda V, \lambda n_1, \lambda n_2, \dots, \lambda n_K) = s(U, V, n_1, n_2, \dots, n_K). \quad (2.12)$$

We can put a factor λ^0 in front of the left-hand side function. This is the reason to call the functions having the above property as *homogeneous zero order functions*.

Postulate 3 states that entropy is a strictly increasing function of energy, differentiable and continuous; thus it can also be inverted to give the internal energy function

$$U = U(S, V, n_1, n_2, \dots, n_K). \quad (2.13)$$

This function can of course also be inverted to provide the entropy function again. We can conclude that specifying the above energy function is equivalent to specifying the entropy function $S(U, V, n_1, n_2, \dots, n_K)$ from which we know that its knowledge makes it possible to describe all equilibrium states of a system. Consequently, (2.13) is also a fundamental equation that we call the *energy-based fundamental equation* to distinguish it from the *entropy-based fundamental equation* given in (2.6).

If entropy is a strictly increasing function of energy, it follows from this property that its inverse function, energy is also a strictly increasing function of the entropy. We can formulate these conditions using partial derivatives of the functions:

$$\left(\frac{\partial S}{\partial U}\right)_{V,n} > 0 \quad \text{and} \quad \left(\frac{\partial U}{\partial S}\right)_{V,n} = \frac{1}{\left(\frac{\partial S}{\partial U}\right)_{V,n}} > 0. \quad (2.14)$$

As we shall see later, the derivative $\left(\frac{\partial U}{\partial S}\right)_{V,n}$ can be identified as the temperature.

Keeping this in mind we can conclude that Postulate 3 also specifies that temperature can only be positive. *Postulate 4* – the last one – is also related to this derivative:

The entropy of any system is non-negative and vanishes in the state for which $\left(\frac{\partial U}{\partial S}\right)_{V,n} = 0$ (that is, at zero temperature).

(This condition is not always fulfilled in practice, as an equilibrium state at zero temperature is often not possible to reach. We shall discuss further this topic in Chap. 10.) It is worth noting here that the zero of the entropy scale is completely determined, similarly to that of the volume V or of the amount of substances

n_1, n_2, \dots, n_K . Internal energy is the only quantity mentioned whose zero point is not determined, but it has this property already in mechanics. Consequently, the zero point of energy is arbitrarily fixed according to some convention. The state of a system where the energy is zero is usually called a *reference state*.

2.2.2 Properties of the Differential Fundamental Equation

The differential form of a fundamental equation is called the *differential fundamental equation*. Let us differentiate both sides of (2.13). This results in the *total differential* dU on the left side and its expression as a function of the infinitesimal increments of the variables $S, V, n_1, n_2, \dots, n_K$:

$$dU = \left(\frac{\partial U}{\partial S} \right)_{V, \mathbf{n}} dS + \left(\frac{\partial U}{\partial V} \right)_{S, \mathbf{n}} dV + \sum_{i=1}^K \left(\frac{\partial U}{\partial n_i} \right)_{S, V, n_{j \neq i}} dn_i. \quad (2.15)$$

Variables of the function different from the one with respect of which we differentiate it are shown as subscripts of the parenthesis enclosing the derivative. The reason is that we can see from this notation what the variables of the function we differentiate are, without additionally specifying them. It is important to note that the variables written as subscripts are constant only from the point of view of the differentiation, but of course they are the variables of the partial derivative as well, so they can change. In the subscripts, we only show the composition vector $\mathbf{n} = (n_1, n_2, \dots, n_K)$ for the sake of brevity. The symbol $n_{j \neq i}$ in the subscript of the derivative with respect to n_i expresses that the variable n_i should not be listed among the “constant” variables during derivation. We shall keep using this notation throughout the book.

Let us examine the meaning of terms on the right side of the equation. Each one contributes to the increment of the energy; thus, they must have energy dimension. The first term

$$(dU)_{V, \mathbf{n}} = \left(\frac{\partial U}{\partial S} \right)_{V, \mathbf{n}} dS \quad (2.16)$$

is the partial differential of the energy if volume and composition are constant; thus, it is in a closed, rigid but diathermal system. In simple systems, this change is only possible via heat transfer, so $(dU)_{V, \mathbf{n}}$ is the *heat absorbed from the surroundings*. In a similar way, the term

$$(dU)_{S, \mathbf{n}} = \left(\frac{\partial U}{\partial V} \right)_{S, \mathbf{n}} dV \quad (2.17)$$

is the infinitesimal energy change as a result of volume change; i.e., the volume work – or mechanical work in simple systems. At constant entropy and volume, the contribution to the change of energy is proportional to dn_i for the change of each of

the components. This energy contribution associated to the change of composition is called *chemical work* or *chemical energy*. An interesting property of this energy increment is that it should be calculated separately for all the components and summed to give the chemical work:

$$(dU)_{S,V} = \sum_{i=1}^K \left(\frac{\partial U}{\partial n_i} \right)_{S,V, n_{j \neq i}} dn_i. \quad (2.18)$$

Let us examine the partial derivatives of the above three equations. It is readily seen that all of them are quotients resulting from the division of two extensive quantities. They are energies relative to entropy, volume, and amount of substance; consequently, they are intensive quantities similar to molar quantities introduced before. Comparing (2.2) and (2.17) we can see that the partial derivative of the energy function $U(S, V, \mathbf{n})$ with respect to volume is the negative pressure, $-P$:

$$\left(\frac{\partial U}{\partial V} \right)_{S, \mathbf{n}} \equiv -P. \quad (2.19)$$

The partial derivative of the energy function $U(S, V, \mathbf{n})$ with respect to entropy is an intensive quantity which, multiplied by the increment of the entropy, gives the heat transferred to the (equilibrium) system. Later on we shall see that this derivative is the *temperature*, as it has all the properties we expect from temperature.

$$\left(\frac{\partial U}{\partial S} \right)_{V, \mathbf{n}} \equiv T. \quad (2.20)$$

One of its expected properties we already see that it is an intensive quantity.

Up to now, all we now about the partial derivative of the energy function $U(S, V, \mathbf{n})$ with respect to the amount of each chemical component is only that it is related to the chemical energy of the corresponding species. Let us call this quantity the *chemical potential of the i -th species*, denote it by μ_i and let us postpone to find its properties.

$$\left(\frac{\partial U}{\partial n_i} \right)_{S,V, n_{j \neq i}} \equiv \mu_i. \quad (2.21)$$

Making use of the identification and notation of the partial derivatives in (2.19)–(2.21), the energy-based differential fundamental equation can be written in a formally simpler way:

$$dU = TdS - PdV + \sum_{i=1}^K \mu_i dn_i. \quad (2.22)$$

Partial derivatives in (2.15) depend on the same variables as the function $U(S, V, \mathbf{n})$ itself. Consequently, all the intensive quantities in (2.22) are also functions of the variables S, V and \mathbf{n} :

$$T = T(S, V, \mathbf{n}), \quad (2.23)$$

$$P = P(S, V, \mathbf{n}), \quad (2.24)$$

$$\mu_i = \mu_i(S, V, \mathbf{n}). \quad (2.25)$$

T , P and all the μ_i -s are intensive quantities; therefore, the functions given by (2.23)–(2.25) are homogeneous zero order functions of their extensive variables. Equations (2.23)–(2.25) have a distinct name; they are called *equations of state*.

We can easily “rearrange” (2.22) to get the differential form of the entropy-based fundamental equation (2.6):

$$dS = \frac{1}{T}dU + \frac{P}{T}dV - \sum_{i=1}^K \frac{\mu_i}{T}dn_i. \quad (2.26)$$

It is worth noting that the intensive quantities emerging in this entropy-based differential fundamental equation represent functions that are different from those in (2.22); even their variables are different. These functions determining the entropy-based intensive quantities are called the *entropy-based equations of state*:

$$\frac{1}{T} = \frac{1}{T}(U, V, \mathbf{n}), \quad (2.27)$$

$$\frac{P}{T} = \frac{P}{T}(U, V, \mathbf{n}), \quad (2.28)$$

$$\frac{\mu_i}{T} = \frac{\mu_i}{T}(U, V, \mathbf{n}). \quad (2.29)$$

2.2.3 The Scale of Entropy and Temperature

From previous studies in mechanics and chemistry, the scales of internal energy, volume, amount of substance and pressure are already known. The scale of the chemical potential is easy to get from the defining equation (2.21); as energy related to the amount of chemical components, it is measured in J/mol units, and its zero point corresponds to the arbitrarily chosen zero of the energy.

The definition of entropy and temperature are closely related and so are their choice of scale and units as well. To measure temperature, several empirical scales have been used already prior to the development of thermodynamics, mostly based on the thermal expansion of liquids. Two of these scales survived and are still widely used in everyday life. The Celsius scale² is commonly used in Europe and most part

²This scale has been suggested by the Swedish astronomer Anders Celsius (1701–1744).

of Asia. Its unit is the degree centigrade (or degree Celsius) denoted as $^{\circ}\text{C}$. Its zero point is the freezing point and 100°C is the boiling point of pure water at atmospheric pressure. The Fahrenheit scale³ is commonly used in North America and many other countries. Its unit is the degree Fahrenheit denoted as $^{\circ}\text{F}$. Its zero point is the freezing point of saturated aqueous salt (NaCl) solution and 100°F is the temperature that can be measured in the rectum of a cow. (Though there exist different versions to explain the choice of the two fixed scale points.) To get the Celsius temperature, 32 should be subtracted from the Fahrenheit temperature and the result should be divided by 1.8. Thus, the freezing point of water is 32°F , its boiling point is 212°F . Common room temperature is around 70°F compared to approximately 21°C , and normal human body temperature is about 98°F compared to 36.7°C .

As we can see, none of these scales is in accordance with the postulates of thermodynamics. Postulate 3 requires a nonnegative temperature and Postulate 4 fixes its zero point. This latter means that we can only fix one single temperature to completely fix the scale. The SI unit of temperature has been fixed using the former Kelvin scale.⁴ According to this, the triple point of water (where liquid water, water vapor and water ice are in equilibrium) is exactly 273.16 K ; thus, the division of the scale is the same as that of the Celsius scale. The unit of the Kelvin scale is denoted simply by K – without the “degree” sign $^{\circ}$. The temperature of the triple point of water on the Celsius scale is 0.01°C ; therefore, we get the temperature in SI units by adding 273.15 to the value of temperature given in $^{\circ}\text{C}$ units:

$$T/\text{K} = t/^{\circ}\text{C} + 273.15. \quad (2.30)$$

The unit of entropy should be determined taking into account the units of energy and temperature, for we know that their product TS should be energy. From statistical thermodynamics (Chap. 10) we know that entropy should be a dimensionless number. Consequently, energy and temperature should have the same dimension; they only could differ in their actual scale. The ratio of the units of these scales, i.e., that of joule and Kelvin, is $k_{\text{B}} = 1.380\,6504 \times 10^{-23}\text{ JK}^{-1}$, and it is called the *Boltzmann constant*. It follows from this result that entropy should also have the unit J/K . However, as temperature is intensive and entropy is extensive, we should multiply the Boltzmann constant by the number of particles to get the extensive unit of entropy. The number of particles is dimensionless, so it would not change the unit if we used the number of particles N to specify the extent of the system. In chemistry, it is more common to use the amount of substance n . The dimension of entropy is not changed by this, as the amount of substance differs only by a “numerosity factor” from the number of particles; this is expressed by the *Avogadro constant* $N_{\text{A}} = 6.022\,141\,79 \times 10^{23}\text{ mol}^{-1}$. Thus, expressing the proportionality of temperature units to the energy units related to one mole of particles results in $R = k_{\text{B}} N_{\text{A}} = 8.314\,472\text{ JK}^{-1}\text{ mol}^{-1}$, which

³This scale has been suggested by the German physicist Daniel Gabriel Fahrenheit (1686–1736).

⁴William Thomson (1824–1907) – after his ennoblement by Queen Victoria, Baron Kelvin of Largs or Lord Kelvin – was a Scottish physicist. He had an important contribution to the establishment of the science of thermodynamics.

is the ratio of the temperature to the molar entropy. Following from this result, $k_B T$ is energy per particle and RT is energy per mole.

2.2.4 Euler Relation, Gibbs–Duhem Equation and Equations of State

It is worth examining the relation between the equations (2.23)–(2.25) and the differential fundamental equation (2.15). Each equation of state only specifies one of the derivatives in the fundamental equation. To construct the complete fundamental equation, we need $K + 2$ derivatives. These derivatives – or equations of state – are mostly determined by experimental measurements.

It is easy to show that the equations of state are not independent of each other, based on the properties of homogeneous first order functions. If $f(x_1, x_2, \dots, x_n)$ is a homogeneous first order function of the variables x_1, x_2, \dots, x_n , the following Euler⁵ theorem holds:

$$f(x_1, x_2, \dots, x_n) = \sum_{i=1}^n \left(\frac{\partial f}{\partial x_i} \right)_{x_{j \neq i}} x_i. \quad (2.31)$$

Let us apply this theorem to the function $U(S, V, n_1, n_2, \dots, n_K)$ which is homogeneous first order with respect to all its variables:

$$U = \left(\frac{\partial U}{\partial S} \right)_{V, n} S + \left(\frac{\partial U}{\partial V} \right)_{S, n} V + \sum_{i=1}^K \left(\frac{\partial U}{\partial n_i} \right)_{S, V, n_{j \neq i}} n_i. \quad (2.32)$$

Substituting the partial derivatives identified before we get:

$$U = TS - PV + \sum_{i=1}^K \mu_i n_i. \quad (2.33)$$

This equation is usually called the (energy-based) *Euler relation*.

Let us write the differential form of this equation by explicitly writing the differentials of the products in each term on the right side:

$$dU = TdS + SdT - PdV - VdP + \sum_{i=1}^K \mu_i dn_i + \sum_{i=1}^K n_i d\mu_i. \quad (2.34)$$

⁵Leonhard Euler (1707–1783) was a Swiss mathematician and physicist working mainly in Saint Petersburg (Russia). He was the most prolific and important scientist of the eighteenth century. His results concerning homogeneous functions are among his “humble” achievements compared to his other theorems.

Subtract from the above equation the following equation – identical to (2.22):

$$dU = TdS - PdV + \sum_{i=1}^K \mu_i dn_i. \quad (2.35)$$

The result is zero on the left side, and three terms only on the right side containing products of extensive quantities multiplied by increments of intensive quantities. By switching sides, we obtain the usual form of the *Gibbs–Duhem equation*:⁶

$$SdT - VdP + \sum_{i=1}^K n_i d\mu_i = 0. \quad (2.36)$$

Thus, the intensive variables T , P and $\mu_1, \mu_2, \dots, \mu_K$ are not independent of each other as the constraint prescribed by the Gibbs–Duhem equation holds. This is in accordance with the observation we made of the intensive characterization of thermodynamic systems; the number of degrees of freedom becomes $K + 1$ instead of $K + 2$. In addition, it is also a useful quantitative relation which enables to calculate the missing equation of state if we already know $K + 1$ of them.

We can also write the *entropy-based Euler relation* from (2.6):

$$S = \frac{1}{T}U + \frac{P}{T}V - \sum_{i=1}^K \frac{\mu_i}{T}n_i, \quad (2.37)$$

from which the *entropy-based Gibbs–Duhem equation* follows immediately:

$$Ud\left(\frac{1}{T}\right) + Vd\left(\frac{P}{T}\right) - \sum_{i=1}^K n_i d\left(\frac{\mu_i}{T}\right) = 0. \quad (2.38)$$

2.2.5 The Fundamental Equation of an Ideal Gas

Based on the previous sections, we can construct the fundamental equation from equations of state determined by experimental measurements. In this section, we will demonstrate this procedure on the example of an *ideal gas*, widely used as an approximation to the behaviour of gaseous systems. The ideal gas is an idealized system for which we suppose the strict validity of approximate empirical relations obtained by experimental studies of low pressure and high temperature gases. It has

⁶Josiah Willard Gibbs (1839–1903) was an American physicist. He was one of the first scientists in the United States who had all of his university studies in the US. His important contributions to thermodynamics included the general theory of phase equilibria and surface equilibria. His formal foundations of statistical thermodynamics are still in use.

been demonstrated that the strict validity of the Boyle–Mariotte, Gay-Lussac, and Avogadro laws known since the seventeenth and eighteenth century require that molecules constituting the gas should behave *independently of each other*. In other words, there should not be any interaction between them, and their size should be small enough so that the summed volume of the particles themselves be negligible compared to the volume of the gas.

One of the relevant equations of state is usually given in the peculiar form what most of us had seen during our studies:

$$PV = nRT. \quad (2.39)$$

This is the so-called *mechanical equation of state* that can be used also to calculate volume work. Another equation of state may also be familiar from previous studies. This is called the *thermal equation of state*:

$$U = \frac{3}{2}nRT. \quad (2.40)$$

(This particular form is valid only for a *monatomic gas*. If the molecules of the ideal gas contain more than one atom, the constant factor is greater than 3/2.) First of all we should decide of the above equations of state, which fundamental equation they are related to. The variables of the energy function given by the energy-based fundamental equation (2.13) are S , V and \mathbf{n} . (As the equations of state above refer to a one-component ideal gas, we shall replace the composition vector \mathbf{n} by the scalar n specifying the amount of substance of this single component.) Apart from the intensive variable T in (2.40) we can find the internal energy U , which is the variable of the entropy function. In (2.39), there are two intensive variables P and T . Consequently, these two equations of state should belong to the entropy-based fundamental equation, so it is worth of writing them in the form of the entropy-based intensive quantities:

$$\frac{P}{T} = R \frac{n}{V}, \quad (2.41)$$

$$\frac{1}{T} = \frac{3}{2}R \frac{n}{U}. \quad (2.42)$$

We can note that P/T depends only on V and n , not on U , and that $1/T$ depends only on U and n , not on V . In both equations, n appears in the numerator of a fraction. Realizing that the division by n results in molar values, we can replace these fractions having n in the numerator by the reciprocal of the corresponding molar values:

$$\frac{P}{T} = \frac{R}{v}, \quad (2.43)$$

$$\frac{1}{T} = \frac{3}{2} \frac{R}{u}. \quad (2.44)$$

With the help of these equations of state, we can start to construct the fundamental equation. If we need the extensive fundamental equation, we also need the third equation of state (for the pure – one-component – ideal gas) specifying μ/T . Obviously, this can be calculated using the Gibbs–Duhem equation (2.38). Dividing it by the amount of substance n and rearranging, we get

$$d\left(\frac{\mu}{T}\right) = u d\left(\frac{1}{T}\right) + v d\left(\frac{P}{T}\right). \quad (2.45)$$

Applying the chain rule, we can substitute the derivatives $d\left(\frac{1}{T}\right) = \frac{d\left(\frac{1}{T}\right)}{du} du$ and $d\left(\frac{P}{T}\right) = \frac{d\left(\frac{P}{T}\right)}{dv} dv$ on the right side. The resulting derivatives can be calculated by differentiating the functions specified in (2.44) and (2.43):

$$d\left(\frac{\mu}{T}\right) = u \left(-\frac{3}{2} \frac{R}{u^2}\right) du + v \left(-\frac{R}{v^2}\right) dv = -\frac{3}{2} \frac{R}{u} du - \frac{R}{v} dv. \quad (2.46)$$

Integrating this function we can get the missing equation of state determining the function μ/T . The first term is a function of only u , the second term is a function of only v , and thus we can integrate the first term only with respect to u and the second one only with respect to v :

$$\int_{u_0, v_0}^{u_1, v_1} d\left(\frac{\mu}{T}\right) = -\frac{3}{2} R \int_{u_0, v_0}^{u_1, v_0} \frac{1}{u} du - R \int_{u_1, v_0}^{u_1, v_1} \frac{1}{v} dv. \quad (2.47)$$

Upon integration we get the following equation of state:

$$\frac{\mu}{T} = \left(\frac{\mu}{T}\right)_0 - \frac{3}{2} R \ln \frac{u}{u_0} - R \ln \frac{v}{v_0}. \quad (2.48)$$

Here, the integration constant $\left(\frac{\mu}{T}\right)_0 = \left(\frac{\mu}{T}\right)(u_0, v_0)$ is the value of the function $\frac{\mu}{T}$ at the reference state of molar energy u_0 and molar volume v_0 .

Having all the three equations of state, we can substitute the appropriate derivatives into the Euler relation (2.37) to get the fundamental equation:

$$S = \frac{3}{2} R n + R n - n \left(\frac{\mu}{T}\right)_0 + n R \left[\frac{3}{2} \ln \frac{u}{u_0} + \ln \frac{v}{v_0} \right]. \quad (2.49)$$

To write this equation in terms of extensive variables, let us make use of the identities $\frac{u}{u_0} = \frac{U}{U_0} \frac{n_0}{n}$ and $\frac{v}{v_0} = \frac{V}{V_0} \frac{n_0}{n}$, rearrange terms by factoring out nR and rewrite sums of logarithms as logarithm of products to have a compact form:

$$S = \frac{5}{2}Rn - n\left(\frac{\mu}{T}\right)_0 + nR \ln \left[\left(\frac{U}{U_0}\right)^{\frac{3}{2}} \left(\frac{V}{V_0}\right) \left(\frac{n}{n_0}\right)^{-\frac{5}{2}} \right]. \quad (2.50)$$

As this equation specifies the S function, it is more practical to include the value of S itself in the reference state, instead of the chemical potential μ . Let us express this reference value as

$$S_0 = S_0(U_0, V_0, n_0) = \frac{5}{2}Rn_0 - n_0\left(\frac{\mu}{T}\right)_0. \quad (2.51)$$

Introducing this constant into the above expression of S , we obtain the compact form of the fundamental equation of an ideal gas:

$$S = \frac{n}{n_0}S_0 + nR \ln \left[\left(\frac{U}{U_0}\right)^{\frac{3}{2}} \left(\frac{V}{V_0}\right) \left(\frac{n}{n_0}\right)^{-\frac{5}{2}} \right]. \quad (2.52)$$

Now we can use this function to calculate equilibria upon any change of state of an ideal gas.

The procedure to get the intensive fundamental equation is less complicated. Having the extensive equation, of course we could simply divide each extensive variable (U , V and n) by n , and the reference values by n_0 . However, it is worth constructing it directly from the two known equations of state (2.44) and (2.43). The intensive fundamental equation only consists of two terms instead of three, for the molar entropy of the pure substance does not depend on its amount:

$$ds = \frac{1}{T}du + \frac{P}{T}dv. \quad (2.53)$$

Substituting the appropriate derivatives after applying the chain rule (as before), we can easily integrate the differential equation thus obtained and get the intensive fundamental equation of an ideal gas:

$$s = s_0 + \frac{3}{2}R \ln u + R \ln v, \quad (2.54)$$

where the constant is the molar entropy in the reference state (u_0, v_0):

$$s_0 = \frac{3}{2}R \ln \frac{1}{u_0} + R \ln \frac{1}{v_0}. \quad (2.55)$$

It is worth noting that neither the extensive entropy of (2.52), nor the above molar entropy function does not fulfill the requirement stated in Postulate 4 of thermodynamics; the value of the function at $T = 0$ is not zero. We should not be surprised as we know that the ideal gas is a good approximation at high temperatures and it cannot be applied at very low temperatures at all. We can

emphasize also at this point that the coefficient $3/2 R$ is valid only for *monatomic gases*. If the molecule has a more complex structure, this coefficient is greater. Later in the text we shall see that it is identical to the heat capacity at constant volume which of course depends on the structure of the molecule. (Cf. Chap. 10.)

2.2.6 *The Fundamental Equation of an Ideal van der Waals Fluid*

The equation of state of the ideal gas is not only used for approximate calculations in the case of *real gases* within the range of applicability, but many other equations of state in use are based on modifications of the ideal gas equation. Historically, one of the first equations aiming a greater generality was introduced by van der Waals⁷ in 1873. Though the *van der Waals equation of state* does not provide a satisfactory description of the behavior of real gases, its underlying principles of including the non-ideal behavior are simple and rather pictorial. They also explain the vapor-liquid transition in a simple way. This is the reason we can find this equation of state along with its rationale in many textbooks. As an example for an alternative of the ideal gas equation, we shall also discuss this equation of state and the resulting fundamental equation. The word *fluid* in the title of the section – a comprehensive designation of liquids and gases – reflects the fact that this description is also valid for liquids, though in a restricted sense.

Let us write the mechanical equation of state in a form suggested by van der Waals:

$$P = \frac{RT}{v - b} - \frac{a}{v^2}. \quad (2.56)$$

There are two differences from that of the ideal gas equation (2.39). In the denominator of the first term, b is subtracted from the molar volume v , and there is an extra term $-a/v^2$. J.D. van der Waals argued that the two corrections reflect the difference between the ideal gas model and real gases. The equation of state (2.39) of the ideal gas can be deduced from a model where molecules are considered as point masses with no finite size and there are no interactions (attractive or repulsive) between them, only elastic collisions. This idealized model is easy to correct in a way to reflect the properties of real gases.

Firstly, the size of molecules is finite, though tiny. This is reflected in the term b which represents the volume excluded by one mole of the nonzero-size molecules, thus not available as free volume. Secondly, molecules attract each other. This

⁷Johannes Diderik van der Waals (1837–1923), the Dutch physicist conceived the first equation of state describing both gases and liquids, later named after him. He also interpreted molecular interactions playing a role in the underlying principles, later called van der Waals forces.

attraction is compensated for in the bulk of the gas (far from the walls of the container) as each molecule is attracted isotropically; they do not “feel” any directional force. However, in the surface layer near the walls, forces acting from the interior of the gas are no more compensated for from the direction of the wall, as there are no gas molecules there. This results in a net force towards the interior of the gas thus decreasing the pressure exercised by the molecules hitting the wall. The force acted on a surface molecule is proportional to the density of molecules in the bulk, which is proportional to the reciprocal molar volume. The force is also proportional to the number of molecules in a surface position which is also proportional to the density, i.e., the reciprocal volume. As a result, the decrease of the pressure is proportional to the square of the reciprocal volume which gives rise to the term $-a/v^2$. Arguing somewhat differently, the force acting on the surface molecules, decreasing the pressure, is proportional to the number of *pairs* of molecules, as the attractive force is acting between two molecules adjacent to the surface. The number of pairs is proportional to the square of density, i.e., the square of the reciprocal molar volume. Before proceeding, we can rewrite (2.56) to express the entropy-based derivative P/T :

$$\frac{P}{T} = \frac{R}{v-b} - \frac{a}{v^2} \frac{1}{T}. \quad (2.57)$$

To construct the fundamental equation – similarly as in Sect. 2.2.5 for the ideal gas – we also need the thermal equation of state. As a first idea, we could use the same equation (2.42) as for the ideal gas. However, it is not a valid choice as it would not satisfy the properties required by the relations of thermodynamics. We have to alter the expression (2.42) of the derivative $1/T$ as a function of the molar energy u and the molar volume v to impose the thermodynamic consistency condition between the two equations of state. We know that $s(u, v)$ is a state function, thus its mixed second partial derivatives should be equal, irrespective of the order of derivation (A1.8):

$$\frac{\partial}{\partial v} \left(\frac{\partial s}{\partial u} \right)_v = \frac{\partial}{\partial u} \left(\frac{\partial s}{\partial v} \right)_u. \quad (2.58)$$

Substituting the first derivatives we get:

$$\frac{\partial}{\partial v} \left(\frac{1}{T} \right) = \frac{\partial}{\partial u} \left(\frac{P}{T} \right). \quad (2.59)$$

Knowing the function P/T , we can calculate the right-hand side as

$$\frac{\partial}{\partial v} \left(\frac{P}{T} \right) = \frac{\partial}{\partial u} \left(\frac{R}{v-b} - \frac{a}{v^2} \frac{1}{T} \right) = -\frac{a}{v^2} \frac{\partial}{\partial u} \left(\frac{1}{T} \right), \quad (2.60)$$

and rewrite the condition in the form

$$\frac{\partial}{\partial v} \left(\frac{1}{T} \right) = - \frac{a}{v^2} \frac{\partial}{\partial u} \left(\frac{1}{T} \right). \quad (2.61)$$

Let us multiply the numerator and denominator on the right side by $1/a$ and put the constant $1/a$ into the variable of the derivation:

$$\frac{\partial(1/T)}{\partial v} = - \frac{1}{v^2} \frac{\partial(1/T)}{\partial(u/a)}. \quad (2.62)$$

Using the chain rule (A1.19), the derivative on the left side can be written as

$$\frac{\partial(1/T)}{\partial v} = \frac{\partial(1/T)}{\partial(1/v)} \frac{d(1/v)}{d(v)} = - \frac{1}{v^2} \frac{\partial(1/T)}{\partial(1/v)}. \quad (2.63)$$

Comparing the two equations, the relation imposed is

$$\frac{\partial(1/T)}{\partial(1/v)} = \frac{\partial(1/T)}{\partial(u/a)}, \quad (2.64)$$

meaning that the searched-for function $1/T$ should have the property that its derivative with respect to the two variables $1/v$ and u/a should be equal. This condition is satisfied if $1/T$ depends only on $(1/v + u/a)$. Let us change (2.42) accordingly, replacing also the factor $3/2$ – applicable only for monatomic gases – by a general factor c :

$$\frac{1}{T} = \frac{cR}{u + a/v}. \quad (2.65)$$

The above equation has been obtained by adapting the equation of state of an ideal gas, thus we can call the system for which this equation along with (2.56) holds, the *ideal van der Waals gas*. Before proceeding, it is worth while to express (2.56) as an explicit function of u and v by substitution of the above expression of $1/T$:

$$\frac{P}{T} = \frac{R}{v - b} - \frac{acR}{uv^2 + av}. \quad (2.66)$$

Having the above equations for the two derivatives of s we can write the total differential

$$ds = \frac{1}{T} du + \frac{P}{T} dv. \quad (2.67)$$

Upon integration we get the intensive fundamental equation:

$$s = s_0 + R \ln \frac{(v - b)(u + a/v)^c}{(v_0 - b)(u_0 + a/v_0)^c}. \quad (2.68)$$

Multiplying this equation by the amount of substance n we obtain the extensive fundamental equation

$$S = S_0 + nR \ln \frac{(v - b)(u + a/v)^c}{(v_0 - b)(u_0 + a/v_0)^c}, \tag{2.69}$$

where $S_0 = ns_0$.

Typical values of the constant a are between 0.003 and 1 Pam^6 , that of b between 2.5×10^{-5} and $10 \times 10^{-5} \text{ m}^3$, while that of c varies between the minimal $3/2$ and about 4 , around room temperature. If the equation is used for actual calculations, the constants are determined from experimental data so that the equations of state would best fit the measured set of data P , V and T .

Problems

1. The energy of a particular gaseous system was found to obey the following equation under certain conditions:

$$U = 5PV + 10 \text{ J}. \tag{2.70}$$

The system is conducted through a cycle ABCD (represented by the continuous straight lines in the figure), starting and ending at point A. Calculate

- (a) The internal energies at points A, B, C, and D
- (b) Heat and work for all four processes (A→B, B→C, C→D, and D→A) of the cycle
- (c) Heat and work, when the system undergoes the process from C to B along the dashed hyperbola h that is described by the following equation:

$$P = \frac{0.4 \text{ kPa}}{(V/\text{dm}^3) - 4}; \tag{2.71}$$

- (d) Find a parametric equation of an adiabatic process in the P - V plane.

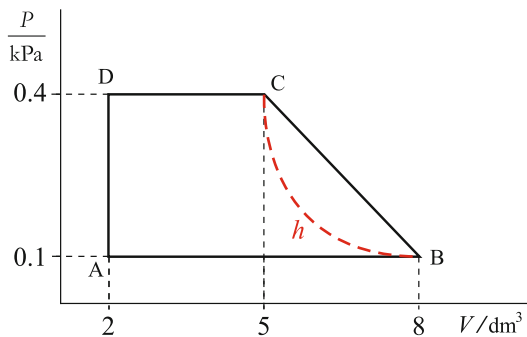

Fig. 2.2 Processes of problem 1 shown in the P - V plane

Solution: (a) The energy in the four states can be calculated by using the formula of U provided in (2.70), reading the values of P and V from the figure: $U_A = 11$ J; $U_B = 14$ J; $U_C = 20$ J; $U_D = 14$ J.

Changes of internal energy for the individual process can be obtained by simple subtractions: $\Delta U_A^B = 3$ J; $\Delta U_B^C = 6$ J; $\Delta U_C^D = -6$ J; $\Delta U_D^A = -3$ J.

(b) In process $D \rightarrow A$, the total change of internal energy occurs as heat, for – as it can be seen in the figure – dV is zero along the line DA , thus the work is zero as well. However, in processes $A \rightarrow B$ and $C \rightarrow D$, the volume does change, and the work can be calculated by the definite integral

$$W = - \int_{\text{initial state}}^{\text{final state}} P dV.$$

Note that P is constant during both processes.

In process $B \rightarrow C$, we have to find an equation of the pressure change in order to calculate the work done:

$$W_{BC} = \int_{8\text{dm}^3}^{5\text{dm}^3} \left(0.1 \frac{\text{kPa}}{\text{dm}^3} V - 0.9 \text{ kPa} \right) dV = 4.65 \text{ J}$$

(c) We can calculate the work in a similar way for the process from C to B along the hyperbola h , using the appropriate pressure change:

$$W_{CB,h} = \int_{5\text{dm}^3}^{8\text{dm}^3} - \frac{0.4\text{kPa}}{V/(1\text{dm}^3) - 4} dV = -3.42 \text{ J}$$

Heat exchange in the processes can be calculated using (2.5). The values of heat and work in the five processes are as follows:

Process	$\Delta U/\text{J}$	W/J	Q/J
$A \rightarrow B$	3	-0.6	3.6
$B \rightarrow C$ (straight)	6	0.75	5.25
$C \rightarrow D$	-6	1.2	-7.2
$D \rightarrow A$	-3	0	-3
$C \rightarrow B$ (hyperbolic)	-6	-0.5545	-5.44548

(d) To find an equation for adiabatic changes in the P - V plane, first we differentiate the U function given in (2.70):

$$dU = 5PdV + 5VdP.$$

In case of an adiabatic process, $TdS = 0$, thus $dU = -PdV$. [Cf. (2.22)]. Combining this latter with the above differential leads to the following differential equation:

$$6PdV + 5VdP = 0.$$

Separating the variables and solving the differential equation leads the following result:

$$PV^{\frac{6}{5}} = \text{constant.}$$

This is the general equation that applies for any adiabatic change. (The equation is also called as an “adiabat.”)

2. *The Sackur–Tetrode equation* (Cf. Chap. 10) is a fundamental equation for a monatomic ideal gas:

$$S = nR \left[\frac{5}{2} + \ln \left(\frac{V}{n} \left[\frac{4 \pi m U}{3 h^2 n} \right]^{3/2} \right) \right]. \quad (2.72)$$

(R , m , π and h are constants.) Check whether the equation meets all the requirements concerning the entropy function that are imposed by the four postulates.

Solution: In order to prove that a particular entropy function meets the requirements imposed by the postulates, we have to prove that it is differentiable if its variables have physically reasonable values; that it is a homogenous first order function of its natural variables; and that it vanishes at $T = 0$.

The differentiability of the function $S(U, V, n)$ can be demonstrated by formally differentiating the function and see if the derivatives obtained exist in the range of physically reasonable values of their variables. These derivatives are the following:

$$\left(\frac{\partial S}{\partial U} \right)_{V, n} = \frac{1}{T} = \frac{3nR}{2U},$$

$$\left(\frac{\partial S}{\partial V} \right)_{U, n} = \frac{P}{T} = \frac{3nR}{V},$$

$$\left(\frac{\partial S}{\partial n} \right)_{U, V} = \frac{\mu}{T} = -R \ln \left[\frac{V}{n} \left(\frac{4 \pi m U}{3 h^2 n} \right)^{3/2} \right].$$

We can see from the results that the derivatives do exist in the physically sound range of their variables.

Whether S is a homogenous first order function of its variables can be checked using the definition given in (2.7):

$$S(\lambda U, \lambda V, \lambda n) = \lambda nR \left[\frac{5}{2} + \ln \left(\frac{\lambda V}{\lambda n} \left[\frac{4 \pi m \lambda U}{3 h^2 \lambda n} \right]^{3/2} \right) \right] = \lambda S(U, V, n).$$

To check if the function S fulfils the requirements of Postulate 4, we express U as a function of T from the above derivative $(\partial S/\partial U)_{V,n}$:

$$U = \frac{3nR}{2T}.$$

Substituting this into (2.72), we get:

$$S = nR \left\{ \frac{5}{2} + \ln \left[\frac{V}{n} \left(\frac{2\pi m RT}{h^2} \right)^{3/2} \right] \right\}.$$

It is easy to demonstrate from the above result that

$$\lim_{T \rightarrow 0} S = -\infty.$$

Summing up we can state that the entropy specified by the Sackur–Tetrode equation fulfils Postulates 1–3, but does not fulfil Postulate 4.

Further Reading

- Callen HB (1985) *Thermodynamics and an introduction to thermostatistics*, 2nd edn. Wiley, New York
- Mohr PJ, Taylor BN, Newell DB (2007) CODATA recommended values of the fundamental physical constants: 2006. National Institute of Standards and Technology, Gaithersburg, MD

Chapter 3

Thermodynamic Equilibrium in Isolated and Isentropic Systems

In the previous chapter, we have concluded that the entropy function (2.6) contains all information of the system from a thermodynamic point of view, enabling the calculation of the state variables in any equilibrium state. In isolated systems – which are rigid, adiabatic and closed, i.e., their internal energy U is constant – the condition of equilibrium following the release of an internal constraint is the maximum of the entropy function. We have also seen that, to describe thermodynamic systems, the energy function $U = U(S, V, \mathbf{n})$ is equivalent to the entropy function $S = S(U, V, \mathbf{n})$; this is the reason to call the equations specifying either functions as fundamental equations. Consequently, we can expect that, if the maximum of the entropy function characterizes equilibrium in composite systems, the function $U = U(S, V, \mathbf{n})$ should also have similar properties.

Entropy is a strictly increasing function of the internal energy, thus the following identity should hold:

$$\left(\frac{\partial S}{\partial U}\right)_{V,\mathbf{n}} = \frac{1}{\left(\frac{\partial U}{\partial S}\right)_{V,\mathbf{n}}} = \frac{1}{T} > 0. \quad (3.1)$$

Making use of this identity, it can be proved that in the state where the entropy function has a maximum, energy also should have an extremum and this should be a minimum. Before proceeding to the mathematical proof, let us show a physical argument to demonstrate that if the energy were not minimal, the entropy could not be maximal in equilibrium.

Suppose that, in a state where entropy is S_0 , which is the maximum in equilibrium, the energy U_0 isn't the minimum; i.e., the smallest possible value consistent with the entropy. Let us withdraw energy from the system at constant entropy, in the form of work so that the energy decreases to $U_0 - \Delta U$. Let us return the energy difference ΔU in form of heat ($Q = \int TdS$) into the system. As a result, the energy would become U_0 again, but the entropy would increase to $S_0 + \Delta S$. If it were

possible, the entropy S_0 could not have been maximal for it increased to $S_0 + \Delta S$ in the restored equilibrium state at the unchanged value U_0 of the energy. Hence we can conclude that the original equilibrium state must have had minimal energy consistent with the entropy. As a consequence, the state surface $S = S(U, V, \mathbf{n})$ should be such that, at constant energy, entropy should be maximal and at constant entropy, energy should be minimal. This is illustrated in Fig. 3.1.

In a formal mathematical proof, let us use the energy function of the composite system in the general form $S(U^\alpha, X_1^\alpha, X_2^\alpha, \dots, X_m^\alpha, U^\beta, X_1^\beta, X_2^\beta, \dots, X_m^\beta)$ with U^α and U^β being the energies of the subsystems α and β , while X_i^α and X_i^β some other

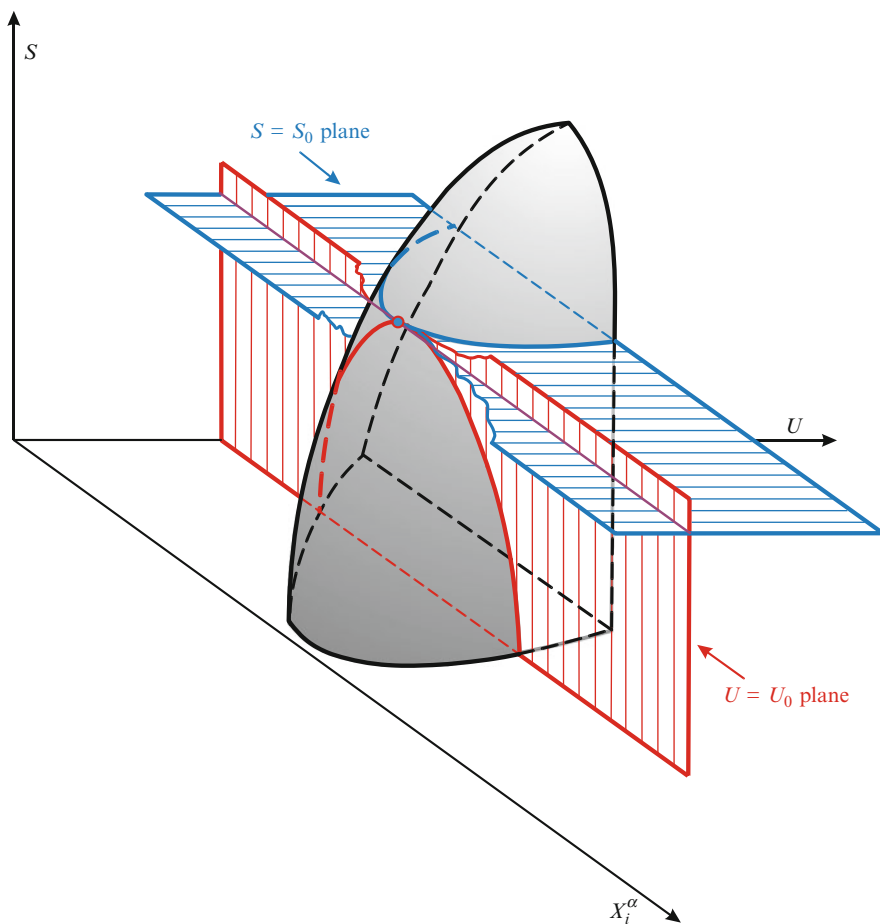

Fig. 3.1 Schematic representation of the entropy maximum and the energy minimum principles on the state surface. The equilibrium energy is U_0 and the equilibrium entropy is S_0 (*small circle*). Coordinate axes shown are the total entropy of the composite system S , its total energy U , and one of the extensive variables X_i^α of the subsystem α . (This latter could have been the extensive variable of the subsystem β as well.) At the point indicated by the *small circle*, $S = S_0$ and $U = U_0$

extensive properties (*e.g.* volumes or amounts of substances), respectively. Similar to the total entropy S , let us denote the total energy of the composite system by $U = U^\alpha + U^\beta$. From here on, let us drop the superscript α or β , and consider the remaining X_i to be either X_i^α or X_i^β ; i.e., an extensive property of any one of the subsystems. At constant energy, the condition that S be maximal can be written with a particular partial derivative with respect to the variable X_i as

$$\left(\frac{\partial S}{\partial X_i}\right)_{U, X_{j \neq i}} = 0 \quad \text{and} \quad \left(\frac{\partial^2 S}{\partial X_i^2}\right)_{U, X_{j \neq i}} < 0. \quad (3.2)$$

(For we will be using only variables U and X_i , we shall also drop other variables $X_{j \neq i}$ from the list of variables in the subscript of partial derivatives. These latter can be considered as constant.) Let us make use of the fact that S , U , and X_i are all state functions, and apply the cyclic rule for them:

$$\left(\frac{\partial S}{\partial X_i}\right)_U \left(\frac{\partial X_i}{\partial U}\right)_S \left(\frac{\partial U}{\partial S}\right)_{X_i} = -1. \quad (3.3)$$

From this, we can express the first derivative of the function $U(S, X_1, X_2, \dots, X_m)$:

$$\left(\frac{\partial U}{\partial X_i}\right)_S = \frac{1}{\left(\frac{\partial X_i}{\partial U}\right)_S} = -\left(\frac{\partial S}{\partial X_i}\right)_U \left(\frac{\partial U}{\partial S}\right)_{X_i}. \quad (3.4)$$

According to (3.2), the derivative of the entropy function in the resulting product is zero. Consequently, the derivative of U with respect to X_i should also be zero which means that *the energy function also has an extremum*.

The second derivative of the U function can be calculated by further differentiating the above product:

$$\begin{aligned} \left(\frac{\partial^2 U}{\partial X_i^2}\right)_S &= \frac{\partial}{\partial X_i} \left[-\left(\frac{\partial S}{\partial X_i}\right)_U \left(\frac{\partial U}{\partial S}\right)_{X_i} \right] \\ &= -\left(\frac{\partial S}{\partial X_i}\right)_U \left(\frac{\partial^2 U}{\partial S \partial X_i}\right) - \left(\frac{\partial^2 S}{\partial X_i^2}\right)_U \left(\frac{\partial U}{\partial S}\right)_{X_i}. \end{aligned} \quad (3.5)$$

In the first term of the resulting expression, we can also find the first derivative of the entropy function with respect to X_i . The second coefficient in the second term, i.e. $(\partial U/\partial S)$, is the temperature which cannot be negative. Thus, we can drop the first term and get

$$\left(\frac{\partial^2 U}{\partial X_i^2}\right)_S = -T \left(\frac{\partial^2 S}{\partial X_i^2}\right)_U, \quad (3.6)$$

from which we can conclude that

$$\text{if } \left(\frac{\partial^2 S}{\partial X_i^2} \right)_U < 0, \quad \text{then } \left(\frac{\partial^2 U}{\partial X_i^2} \right)_S > 0. \quad (3.7)$$

We can summarize the result that, if the equilibrium condition at constant energy (*isolated* system) is the maximum of entropy, then the corresponding equilibrium condition at constant entropy (*isentropic* system) is the minimum of energy. This result reassures that, if there is no heat effect, we get back the condition of mechanical equilibrium; the minimum of energy. In other words, Postulate 3 guarantees that if there is no heat effect, the energy minimum principle known from mechanics is valid as an equilibrium condition.

Consequently, when examining different equilibria, we will have two possibilities; either we maximize the entropy (if the energy is constant), or we minimize the energy (if the entropy is constant). As we will see later, there are other state functions whose extrema offer simple criteria to find equilibrium within different conditions. Therefore, when solving thermodynamic problems, we have to consider carefully what state functions are appropriate to use.

3.1 Thermal Equilibrium

Let us examine the conditions of thermal equilibrium in an isolated system first, where the internal energy U is constant. The isolated system is divided into two subsystems by a rigid, impermeable and adiabatic wall (see Fig. 3.2). The initial equilibrium is specified by the variables U^α , V^α and \mathbf{n}^α in the subsystem α , and U^β , V^β , and \mathbf{n}^β in the subsystem β . Let us remove the heat insulator from the internal wall to make it diathermal, instead of adiabatic. As a result, a heat transfer across the internal wall can change the state of both subsystems. We would like to calculate the new equilibrium state characterized by the variables U^α , V^α , \mathbf{n}^α and U^β , V^β , \mathbf{n}^β of the subsystems.

Releasing adiabaticity, the internal wall still remains rigid and impermeable so that the following conditions are valid. There is no material transport across the wall imposing the condition $dn_i^\alpha = dn_i^\beta = 0$ for all components i . The volume is constant in both subsystems; thus, $dV^\alpha = dV^\beta = 0$. As the overall system is isolated, the total energy cannot change, thus $U = U^\alpha + U^\beta$ is constant. The new equilibrium is characterized by the maximum of entropy, which requires $dS = 0$ to hold. As entropy is an extensive (additive) quantity,

$$S = S^\alpha(U^\alpha, V^\alpha, \mathbf{n}^\alpha) + S^\beta(U^\beta, V^\beta, \mathbf{n}^\beta) \quad (3.8)$$

also holds. As a consequence, the differential of the entropy can be given as

$$dS = dS^\alpha + dS^\beta. \quad (3.9)$$

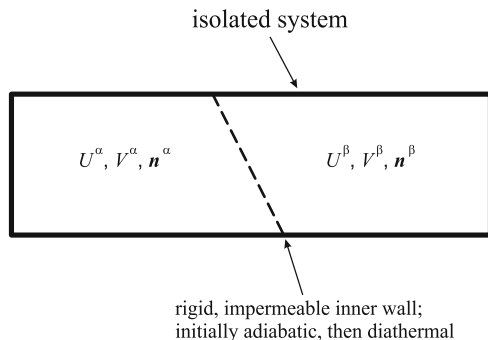

Fig. 3.2 Arrangement and notation to calculate the equilibrium state in an isolated system. The overall system is isolated. The wall separating subsystems α and β is initially rigid, impermeable, and adiabatic. To obtain the new equilibrium state, the heat insulator is removed from the internal wall to make it diathermal

The total differential of the function $S(U, V, \mathbf{n})$ as a function of its variables' differentials can be given as:

$$\begin{aligned}
 dS = & \left(\frac{\partial S^\alpha}{\partial U^\alpha} \right)_{V^\alpha, \mathbf{n}^\alpha} dU^\alpha + \left(\frac{\partial S^\alpha}{\partial V^\alpha} \right)_{U^\alpha, \mathbf{n}^\alpha} dV^\alpha + \sum_{i=1}^K \left(\frac{\partial S^\alpha}{\partial n_i^\alpha} \right)_{U^\alpha, V^\alpha, n_{j \neq i}^\alpha} dn_i^\alpha \\
 & + \left(\frac{\partial S^\beta}{\partial U^\beta} \right)_{V^\beta, \mathbf{n}^\beta} dU^\beta + \left(\frac{\partial S^\beta}{\partial V^\beta} \right)_{U^\beta, \mathbf{n}^\beta} dV^\beta + \sum_{i=1}^K \left(\frac{\partial S^\beta}{\partial n_i^\beta} \right)_{U^\beta, V^\beta, n_{j \neq i}^\beta} dn_i^\beta.
 \end{aligned} \tag{3.10}$$

By applying the conditions $dV^\alpha = dV^\beta = 0$ and $dn_i^\alpha = dn_i^\beta = 0$, only the terms multiplied by dU^α and dU^β will be different from zero, thus the total differential of S will contain only these two terms:

$$dS = \left(\frac{\partial S^\alpha}{\partial U^\alpha} \right)_{V^\alpha, \mathbf{n}^\alpha} dU^\alpha + \left(\frac{\partial S^\beta}{\partial U^\beta} \right)_{V^\beta, \mathbf{n}^\beta} dU^\beta. \tag{3.11}$$

The partial derivative in the first term – according to (2.26) – is $1/T^\alpha$, while that in the second term is $1/T^\beta$. Substituting these in the above equation we get:

$$dS = \frac{1}{T^\alpha} dU^\alpha + \frac{1}{T^\beta} dU^\beta. \tag{3.12}$$

The sum $U = U^\alpha + U^\beta$ is constant if $-dU^\alpha = dU^\beta$ holds. Upon substitution of this identity we obtain

$$dS = \frac{1}{T^\alpha} dU^\alpha - \frac{1}{T^\beta} dU^\alpha = \left(\frac{1}{T^\alpha} - \frac{1}{T^\beta} \right) dU^\alpha. \tag{3.13}$$

At the searched-for maximum of S , dS is zero. As the increment dU^α may assume any value, it is the difference of reciprocal temperatures (in parentheses) that should be zero. Thus, the condition of equilibrium is:

$$\frac{1}{T^\alpha} = \frac{1}{T^\beta}. \quad (3.14)$$

This result implies that *in thermal equilibrium, the temperatures of the two subsystems are equal*, and is in complete accordance with the expected properties of temperature, which supports that

$$\left(\frac{\partial S}{\partial U} \right)_{V, \mathbf{n}} = \frac{1}{T}.$$

Based on (3.13), we can reveal another important property of temperature. Before actually reaching its maximum at equilibrium, the function S should increase, thus the differential dS is positive. If the difference

$$\frac{1}{T^\alpha} - \frac{1}{T^\beta}$$

on the right side of (3.13) is positive, i.e. $T^\beta > T^\alpha$, then the increment dU^α should also be positive to result in a positive differential dS . This implies that, during the process towards the new equilibrium state, energy flows from the higher temperature subsystem (in this case, β) to the lower temperature subsystem (in this case, α). This is another expected property of temperature.

Thus the result is in accordance with our expectations, but we still did not answer the original question: what are the values in the new equilibrium U^α , V^α , \mathbf{n}^α and U^β , V^β , \mathbf{n}^β of the state variables of the subsystems. Due to the rigid and impermeable internal wall, V^α and \mathbf{n}^α , as well as V^β and \mathbf{n}^β cannot change. Thus we have to determine only two variables, U^α and U^β . As we have two equations:

$$U = U^\alpha + U^\beta = \text{constant}, \quad (3.15)$$

and

$$\frac{1}{T^\alpha}(U^\alpha, V^\alpha, \mathbf{n}^\alpha) = \frac{1}{T^\beta}(U^\beta, V^\beta, \mathbf{n}^\beta), \quad (3.16)$$

we can solve them and get U^α and U^β as results.

As we know from the introduction of the present chapter, the same problem in an isentropic system (i.e., of constant entropy) can be solved by minimizing the energy. In such systems, energy can change so it is practical to use the variables S , V and \mathbf{n} and the energy-based fundamental equation to characterize different states. Thus, the initial equilibrium is specified by the variables S^α , V^α and \mathbf{n}^α in the subsystem α , and S^β , V^β , and \mathbf{n}^β in the subsystem β (see Fig. 3.3).

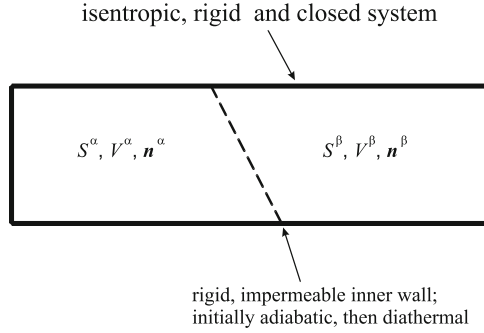

Fig. 3.3 Arrangement and notation to calculate the equilibrium state in an isentropic system. The overall system is isentropic. The wall separating subsystems α and β is initially rigid, impermeable, and adiabatic. To obtain the new equilibrium state, the heat insulator is removed from the internal wall to make it diathermal

The task is now to determine the new equilibrium state characterized by the variables $S^\alpha, V^\alpha, \mathbf{n}^\alpha$ and $S^\beta, V^\beta, \mathbf{n}^\beta$ of the subsystems following the removal of heat insulation of the internal wall. Conditions are quite similar to those already described in an isolated system; $dn_i^\alpha = dn_i^\beta = 0$ as the composition cannot change, and $dV^\alpha = dV^\beta = 0$ as the volume cannot change. The overall system is isentropic; thus, $S = S^\alpha + S^\beta$ is constant. The overall energy is the sum of the energy of the constituent subsystems. Its total differential

$$\begin{aligned}
 dU = & \left(\frac{\partial U^\alpha}{\partial S^\alpha} \right)_{V^\alpha, \mathbf{n}^\alpha} dS^\alpha + \left(\frac{\partial U^\alpha}{\partial V^\alpha} \right)_{S^\alpha, \mathbf{n}^\alpha} dV^\alpha + \sum_{i=1}^K \left(\frac{\partial U^\alpha}{\partial n_i^\alpha} \right)_{S^\alpha, V^\alpha, n_{j \neq i}^\alpha} dn_i^\alpha \\
 & + \left(\frac{\partial U^\beta}{\partial S^\beta} \right)_{V^\beta, \mathbf{n}^\beta} dS^\beta + \left(\frac{\partial U^\beta}{\partial V^\beta} \right)_{S^\beta, \mathbf{n}^\beta} dV^\beta + \sum_{i=1}^K \left(\frac{\partial U^\beta}{\partial n_i^\beta} \right)_{S^\beta, V^\beta, n_{j \neq i}^\beta} dn_i^\beta,
 \end{aligned} \tag{3.17}$$

becomes simple due to the conditions $dn_i^\alpha = dn_i^\beta = 0$ and $dV^\alpha = dV^\beta = 0$, consisting only of the two remaining terms. Substituting the respective temperatures for the partial derivatives of U with respect to S we get the equilibrium condition:

$$dU = T^\alpha dS^\alpha + T^\beta dS^\beta \tag{3.18}$$

In the isentropic system, the two entropy changes should compensate each other so that $-dS^\alpha = dS^\beta$. Substituting $-dS^\alpha$ for dS^β and rearranging the equation we get the resulting dU that should equal zero at the minimum:

$$dU = (T^\alpha - T^\beta) dS^\alpha = 0 \tag{3.19}$$

As the increment dS^α may assume any value, it is the difference $T^\alpha - T^\beta$ that should be zero. Thus, we have obtained the same condition as in isolated systems; namely, that temperatures should be equal in thermal equilibrium.

In addition, we can also deduce the direction of heat flow in case of temperature difference. Before actually reaching its minimum at equilibrium, the function U should decrease, thus the differential dU is negative. If the difference $T^\alpha - T^\beta$ on the right side of (3.19) is negative, i.e., $T^\beta > T^\alpha$, then the increment dS^α should be positive to result in a negative differential dU . This means that energy (in the form of heat) flows from the higher temperature region β to the lower temperature region α prior to equilibrium.

Due to the rigid and impermeable internal wall, V^α and n^α , as well as V^β and n^β remain the same as in the initial state. To describe the equilibrium, we have to determine two variables, S^α and S^β . They can be calculated by solving the two equations:

$$S = S^\alpha + S^\beta = \text{constant}, \quad (3.20)$$

$$T^\alpha(S^\alpha, V^\alpha, n^\alpha) = T^\beta(S^\beta, V^\beta, n^\beta). \quad (3.21)$$

3.2 Thermal and Mechanical Equilibrium

Let us find the condition of mechanical equilibrium in an isentropic system the following way. By removing rigidity and thermal insulation from the internal wall of Fig. 3.3, it remains impermeable but flexible and diathermal. (It is easy to allow for flexibility in a cylinder similar to the one in Fig. 2.1; we can release the fixing device and let the piston move freely.)

The overall system is isentropic, thus $S = S^\alpha + S^\beta$ is constant and $-dS^\alpha = dS^\beta$. As the overall volume cannot change due to the rigidity, $-dV^\alpha = dV^\beta$. The impermeable internal and external walls do not allow the composition of either subsystems change, thus $dn_i^\alpha = dn_i^\beta = 0$. In equilibrium, the energy is minimum, whose condition is $dU = 0$. When writing the total differential of the overall energy $U = U^\alpha(S^\alpha, V^\alpha, n^\alpha) + U^\beta(S^\beta, V^\beta, n^\beta)$, we can drop the derivatives with respect to n_i multiplied by the increments dn_i as these latter are all zero. Thus, the equilibrium condition can be written as:

$$dU = \left(\frac{\partial U^\alpha}{\partial S^\alpha} \right)_{V^\alpha, n^\alpha} dS^\alpha + \left(\frac{\partial U^\alpha}{\partial V^\alpha} \right)_{S^\alpha, n^\alpha} dV^\alpha + \left(\frac{\partial U^\beta}{\partial S^\beta} \right)_{V^\beta, n^\beta} dS^\beta + \left(\frac{\partial U^\beta}{\partial V^\beta} \right)_{S^\beta, n^\beta} dV^\beta = 0. \quad (3.22)$$

Let us substitute in place of the increments with superscript β those with superscript α multiplied by -1 and the respective intensive quantities in place of the derivatives:

$$dU = T^\alpha dS^\alpha - T^\beta dS^\alpha - P^\alpha dV^\alpha + P^\beta dV^\alpha = 0. \quad (3.23)$$

Factoring out the increments dS^α and dV^α , we get the compact form of the necessary condition of equilibrium:

$$dU = (T^\alpha - T^\beta) dS^\alpha - (P^\alpha - P^\beta) dV^\alpha = 0. \quad (3.24)$$

As the increments dS^α and dV^α may assume any values, the condition of thermal and mechanical equilibrium are the simultaneous equalities $T^\alpha = T^\beta$ and $P^\alpha = P^\beta$. The first condition is – not surprisingly – the same as what we have got in the previous section. The equality of pressures as the condition of mechanical equilibrium is also familiar from mechanical studies, thus we merely note that the same result also follows from the condition of thermodynamic equilibrium – as expected.

In the new equilibrium state, due to the closure condition, n^α and n^β will be the same as before. To determine the new equilibrium state, we should calculate the new values of S^α , S^β , V^α and V^β , which can be done by solving the following four simultaneous equations:

$$S = S^\alpha + S^\beta = \text{constant}, \quad (3.25)$$

$$V = V^\alpha + V^\beta = \text{constant}, \quad (3.26)$$

$$T^\alpha(S^\alpha, V^\alpha, n^\alpha) = T^\beta(S^\beta, V^\beta, n^\beta), \quad (3.27)$$

$$P^\alpha(S^\alpha, V^\alpha, n^\alpha) = P^\beta(S^\beta, V^\beta, n^\beta). \quad (3.28)$$

The condition of thermal and mechanical equilibrium can also be deduced in isolated systems. The result – similarly as in Sect. 3.1 – is the same; temperature and pressure should be identical throughout the composite system.

3.3 Thermal and Chemical Equilibrium

We can speak of *chemical equilibrium* if the internal constraint enables for chemical components to pass from one subsystem into another, i.e., the amounts of substances n_i^α and n_i^β to change. Let us consider the most simple such case in an isolated system when the initial equilibrium in a system shown in Fig. 3.2 can change by not only removing the inner thermal insulation but also allowing one single component (denoted by the subscript i) to pass across the internal wall. (This kind of wall which is permeable to one component and impermeable to all others is called *semipermeable*.)

Similarly to the previous considerations of equilibria, let us write the initial conditions first. For the whole isolated system, energy is constant which can be written as $-dU^\alpha = dU^\beta$. The entire system as well as the internal wall is rigid, thus the volumes of the subsystems cannot change, equivalent to $dV^\alpha = dV^\beta = 0$.

The internal wall is impermeable to all components but the i -th; which can be formulated as $dn_i^\alpha = dn_i^\beta = 0$ for all j except for i . The outer wall of the overall system is impermeable also for the component i , thus $-dn_i^\alpha = dn_i^\beta$. In equilibrium, the entropy is maximal which can be formulated as $dS = 0$. When writing the differential of the entropy $S = S^\alpha(U^\alpha, V^\alpha, \mathbf{n}^\alpha) + S^\beta(U^\beta, V^\beta, \mathbf{n}^\beta)$ of the overall system, derivatives with respect to V^α and V^β multiplied by the respective volume increments dV^α and dV^β can be dropped as they are zero. Similarly, derivatives with respect to n_j in either subsystems multiplied by the respective increments dn_j are also zero, due to the closure condition. The resulting equation for the equilibrium condition – after substituting intensive variables in place of the respective derivatives – can be written as:

$$dS = \frac{1}{T^\alpha} dU^\alpha + \frac{1}{T^\beta} dU^\beta - \frac{\mu_i^\alpha}{T^\alpha} dn_i^\alpha - \frac{\mu_i^\beta}{T^\beta} dn_i^\beta = 0. \quad (3.29)$$

By applying the conditions $-dU^\alpha = dU^\beta$ and $-dn_i^\alpha = dn_i^\beta$, factoring out the identical increments we get:

$$dS = \left(\frac{1}{T^\alpha} - \frac{1}{T^\beta} \right) dU^\alpha - \left(\frac{\mu_i^\alpha}{T^\alpha} - \frac{\mu_i^\beta}{T^\beta} \right) dn_i^\alpha = 0. \quad (3.30)$$

The increments dU^α and dn_i^α may assume any values, the condition of equilibrium are the validity of the simultaneous equations:

$$\frac{1}{T^\alpha} - \frac{1}{T^\beta} = 0, \quad (3.31)$$

$$\frac{\mu_i^\alpha}{T^\alpha} - \frac{\mu_i^\beta}{T^\beta} = 0. \quad (3.32)$$

This result implies that, in equilibrium, $T^\alpha = T^\beta$ and $\mu_i^\alpha = \mu_i^\beta$ also holds. We could expect the equality of temperatures based on previous results. We can conclude that the *chemical potential also obeys the general rule that the intensive quantity characterizing an allowed interaction between the subsystems is identical throughout the composite system in equilibrium*. Thus, the chemical potential introduced into the thermodynamic formalism as a new quantity also has a particular meaning. Based on (3.30), we can derive another property of the chemical potential. If thermal equilibrium is already achieved, i.e., $T^\alpha = T^\beta$, then the entropy should increase during the transport across the internal wall of component i until chemical equilibrium will also be achieved. Supposing that $\mu_i^\alpha > \mu_i^\beta$, the increment dn_i^α should also be positive to result in a positive differential dS in (3.30). This implies that, during the process towards the new equilibrium state, chemical components are transported from the higher chemical potential region to the lower chemical potential region.

It is worth noting that, while the condition of mechanical and thermal equilibrium is only the identity of a single intensive quantity – pressure or temperature, respectively – all over the system, the condition of chemical equilibrium is the identity of the respective chemical potentials *for every component which is free to move between the subsystems*.

In the above examples for the calculation of the equilibrium values of the variables characterizing the thermodynamic system, we have allowed for not more than two interactions across the internal wall. Allowing for more – even for all possible – interactions, can be described in a similar way. Every new interaction results in a new term in the differential equation describing the condition of equilibrium. Accordingly, we will get two additional equations which increases the number of simultaneous equations to solve; thus, we can determine the values of all the necessary variables in both subsystems. The observant reader might have noticed that we have used as equilibrium criterion the vanishing of the derivative of the appropriate function (energy or entropy) at the extremum. Of course it does not follow from this condition whether the extremum is a minimum or a maximum. We will discuss this point in more detail in following chapters.

Problems

1. There are two containers, A and B, both filled with a monatomic ideal gas, having the same volume of 2 m^3 . The containers are completely isolated from their environment, and are separated from each other by a non-permeable, rigid and adiabatic wall. Container A holds 3 moles, container B holds 5 moles of the gas. Container A initially has a temperature of 600 K and the total energy in the composite system is 35 kJ.
 - (a) Calculate the internal energy in the two subsystems, and the temperature of container B.
 - (b) Calculate the pressure in the two containers.
 - (c) What is the temperature of the system if we let the wall separating the two containers become diathermal? How does the pressure change in each of the containers?
 - (d) What is the pressure in the two containers, if we let the wall separating them become flexible? How does this affect the temperature in the two subsystems, and does the volume of the containers change?
 - (e) What is the common temperature and pressure of the two subsystems, if we let the wall become diathermal and flexible at the same time?

Solution: To solve the problem, the following two equations of state (valid for monatomic ideal gas) are used:

$$U = \frac{3}{2}nRT,$$

$$P = \frac{nRT}{V}.$$

- (a) Using the above equations and the data given, considering the additivity of the internal energies, we can calculate that $U_A = 22.447$ kJ, $U_B = 12.552$ kJ and $T_B = 201.3$ K.
- (b) In a similar way, we get $P_A = 7.483$ kPa and $P_B = 4.184$ kPa.
- (c) If we let the wall become diathermal, the temperature in the two subsystems will be equal in the new equilibrium state: $T' = T'_A = T'_B$. Since

$$35 \text{ kJ} = \frac{3}{2} \cdot 8RT',$$

the common temperature of the two containers is $T' = 201.3$ K. The pressure naturally will also change in both of the subsystems (for each undergoes an isochoric change of state). The new equilibrium pressures can be calculated from the mechanical equation of state, resulting in $P'_A = 4.375$ kPa and $P'_B = 7.291$ kPa.

- (d) If we let the original wall separating the two containers become flexible, then the pressure would become equal in both subsystems and the volumes will change. Combining the two equations of state, we can write:

$$\frac{3}{2}P'V'_A + \frac{3}{2}P'V'_B = 35 \text{ kJ}.$$

Another equation can be written for the additivity of volumes:

$$V'_A + V'_B = 4 \text{ m}^3.$$

Solving the simultaneous equations yields $P' = 5.833$ kPa, $V'_A = 2.57\text{m}^3$ and $V'_B = 1.43\text{m}^3$.

- (e) If we allow the system to reach both thermal and mechanical equilibrium by letting the internal wall become diathermal and flexible at the same time, the solution of the two equations of state yields a common temperature and pressure of $T = 350.8$ K and $P = 5.833$ kPa in both subsystems.
2. In an isolated composite system, each of the single-component subsystems is characterized by the fundamental equation:

$$S = a \sqrt[3]{nVU}.$$

The subsystems are in thermal equilibrium with each other. The ratio of their amounts of substance is 1:3 and the ratio of their internal energies is 1:2, respectively. Calculate the ratio of the volumes of the subsystems.

Solution: According to (3.14), the condition of thermal equilibrium is that:

$$\frac{1}{T^\alpha} = \frac{1}{T^\beta}$$

Let us express first the inverse temperature of the subsystems:

$$\frac{1}{T} = \left(\frac{\partial S}{\partial U} \right)_{V, n} = \frac{3U}{a \sqrt[3]{nUV}}$$

The inverse temperature of each subsystem can be written according to this result. Substituting multiples of the quantities in subsystem α into the expression concerning subsystem β according to the ratios given, we get:

$$\frac{3U^\alpha}{a \sqrt[3]{n^\alpha U^\alpha V^\alpha}} = \frac{6U^\alpha}{a \sqrt[3]{3n^\alpha \cdot 2U^\alpha V^\alpha}}$$

Solving this equation for the ratio of the volumes of the two subsystems we get:

$$\frac{V^\beta}{V^\alpha} = \frac{4}{3}$$

Further Reading

Callen HB (1985) Thermodynamics and an introduction to thermostatistics, 2nd edn. Wiley, New York

Chapter 4

Thermodynamic Equilibrium in Systems with Other Constraints

Up to now, we have only dealt with equilibria in isolated systems and rigid, impermeable isentropic systems. In industry and in the laboratory, systems at constant pressure, or constant temperature, or at constant values of both of them are much more common. Usually, these (simple) systems exchange energy with the surroundings in form of heat or volume work, or both. This necessitates formulating equilibrium criteria within these conditions as well. As we shall see in this chapter, these tasks can be solved with the help of new energy-like quantities in a simple way.

In the laboratory, the most common constant pressure system is an open flask in contact with the atmosphere that surrounds it. Constant temperature can also be maintained by diathermal contact with the surrounding atmosphere, if heat effects are small so that heat exchange with the atmosphere is enough to keep the temperature constant. In both cases, the external “container” that serves to exchange heat or work with the system has an infinite size, thus compensating for any internal changes in the system. However, to ensure constant pressure or temperature, controlled devices such as a *manostat* or a *thermostat* are used. With the help of these devices, pressure or temperature (or both) can easily be controlled and measured, even if the change in volume or the exchanged heat is relatively large. (This cannot be done concerning entropy; there is no entropy-sensing or measuring device, neither can entropy be held constant easily. Thus, it is a rather complicated task to implement an isentropic system.) Therefore, it is desirable to introduce functions that describe thermodynamic systems as a function of these easily controllable variables. As it turns out from the following sections, by characterizing equilibria within these conditions, we readily get the appropriate functions.

4.1 Equilibrium in Constant Pressure Systems: The Enthalpy Function

Based on the previous treatments of equilibria in closed, rigid, and isentropic systems, we can treat equilibria at constant pressure in the following way. We put the equilibrium system of our interest at constant pressure into a container, which is closed, rigid, and isentropic. Constant pressure is maintained within the system inside this container so that the walls of the internal system are flexible; thus, its pressure is always the same as that of the container. This can be done in two ways. Either we choose a container of infinite dimensions whose pressure would not change while it compensates for volume changes inside the inner system, or we keep the pressure of the container constant using a control device – a manostat. As a result, the container serves as a *reservoir of volume* for the internal subsystem. The arrangement and notation to describe equilibrium are shown in Fig. 4.1.

The condition of equilibrium in the isentropic, rigid, and impermeable container is the minimum of energy. The total energy of the composite system is the sum of the energy of the inner system U and that of the reservoir U^r . The minimum condition of the total energy can then be written as follows:

$$d(U + U^r) = 0 \quad (4.1)$$

Due to its rigid and impermeable outer wall and constant entropy, the energy of the reservoir can only be changed via interactions with the internal subsystem. The walls of this latter – as they are impermeable and adiabatic but flexible – only enable exchange of volume work with the reservoir:

$$dU^r = -P^r dV^r \quad (4.2)$$

The volume within the container – due to the rigidity of the outer walls – is constant, thus the volume change of the reservoir should be exactly compensated for

Fig. 4.1 Arrangement and notation to calculate the equilibrium state of an isentropic system in a manostat. The overall system is isentropic, rigid, and impermeable. The wall separating the inner subsystem (delimited by *dashed lines*) is flexible, so that the pressure P in the inner system is always identical to P^r , the pressure of the container

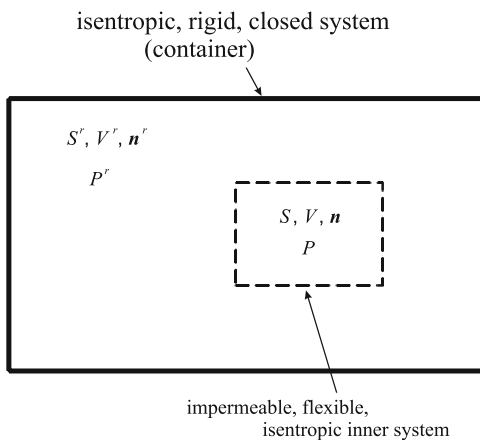

by the volume change of the inner subsystem; $dV = -dV^r$. Taking this into account, we can write the differential of the total energy of the composite system as follows:

$$d(U + U^r) = dU - P^r dV^r = dU + P^r dV = 0 \quad (4.3)$$

Let us make use of the identity of the pressure P of the inner subsystem with that of the reservoir P^r ; $P = P^r$. Substitution of this identity yields

$$dU + PdV = d(U + PV) = 0 \quad (4.4)$$

for the condition of equilibrium. (We can include the factor P within the differential as it is a constant.)

The necessary condition of equilibrium formulated in (4.4) expresses the fact that if we want to characterize the equilibrium of a *constant pressure, closed isentropic system* (in a manostat) *we do not need any data of the manostat* except for the constant pressure; the equilibrium of the system is characterized by the minimum of the function $U + PV$. This function is called *enthalpy*.¹ Its important properties can be derived from the function $U(S, V, \mathbf{n})$. Let us denote the enthalpy function by H and write its definition based on (4.4) as:

$$H = U + PV. \quad (4.5)$$

We can write the differential of this function by substituting (2.22) as the differential of U and writing the differential of the product PV in two terms as:

$$dH = TdS - PdV + \sum_{i=1}^K \mu_i dn_i + PdV + VdP \quad (4.6)$$

As the sum of the terms $-PdV$ and $+PdV$ cancels, the differential of H is

$$dH = TdS + VdP + \sum_{i=1}^K \mu_i dn_i \quad (4.7)$$

We can observe that the total differential is given as a function of the increments of S , P , and the composition vector \mathbf{n} ; thus, the entropy function $H(S, P, \mathbf{n})$ is a state function. From the definition (4.5) of the H function, it can be seen that the function $U(S, V, \mathbf{n})$ can readily be constructed from H . As the equation specifying the function $U(S, V, \mathbf{n})$ is a fundamental equation, the equation

$$H = H(S, P, \mathbf{n}) \quad (4.8)$$

specifying the function $H(S, P, \mathbf{n})$ is also a fundamental equation, and (4.7) is the corresponding differential fundamental equation. This is in complete accordance

¹Enthalpy has a Greek origin, similar to energy. The ancient Greek noun *ενεργεια* [energeia] means actively used power, or work done. It is derived from the word *εργον* [ergon] = work, action. In a similar way, the coined Greek word *ενθαλπεια* [enthalpeia] can be derived from the word *θαλπος* [thalposz] = warming effect. It refers to the heat absorbed.

with the conclusion that the equilibrium of constant pressure, closed isentropic systems can be characterized by the minimum of the enthalpy function. Note that the independent variable of the enthalpy function in the fundamental equation is pressure, instead of volume.

4.2 Equilibrium in Constant Temperature and Constant Volume Systems: The Free Energy Function

Similarly as in the previous section, we put the equilibrium system of our interest at constant temperature into a container, which is closed, rigid, and isentropic. Constant temperature is maintained within the system inside this container so that the walls of the internal system are diathermal; thus, its temperature is always the same as that of the container, which is constant. This can also be done in two ways. Either we choose a container of infinite size whose temperature would not change while it compensates for entropy changes inside the inner system, or we keep the temperature of the container constant using a control device – a *thermostat*. As a result, the container serves as a *reservoir of entropy* for the internal subsystem. The arrangement and notation to describe equilibrium are shown in Fig. 4.2.

The condition of equilibrium inside the container is again the minimum of the total energy, which is the sum of the energy of the inner system U and that of the reservoir U^r . Thus the minimum condition can be written as follows:

$$d(U + U^r) = 0 \quad (4.9)$$

Due to its rigid and impermeable outer wall and constant entropy, the energy of the reservoir can only change via interactions with the internal subsystem. The

Fig. 4.2 Arrangement and notation to calculate the equilibrium state of an isentropic system in a thermostat. The overall system is isentropic, rigid, and impermeable. The wall separating the inner subsystem (delimited by dashed lines) is diathermal, so that the temperature T in the inner system is always identical to the constant temperature T^r of the container

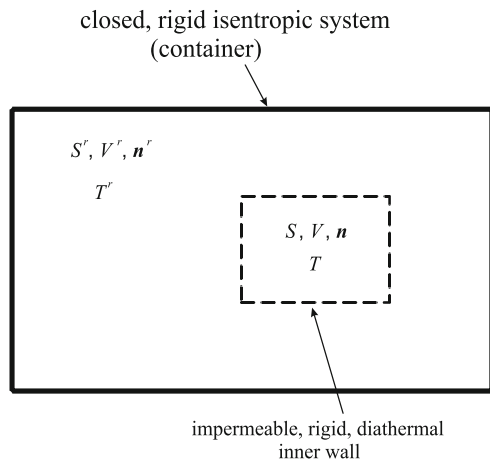

walls of the latter are impermeable and rigid, but diathermal, which only enables exchange of energy in the form of heat with the reservoir:

$$dU^r = T^r dS^r \quad (4.10)$$

The composite system within the container is isentropic; thus, the entropy change in the reservoir is compensated for by the entropy change of the inner subsystem; $dS = -dS^r$. Taking this into account, we can write the differential of the total energy of the composite system as follows:

$$d(U + U^r) = dU + T^r dS^r = dU - T^r dS = 0 \quad (4.11)$$

Let us substitute the constant temperature T of the inner subsystem in place of T^r of the container (as they are identical). Including the constant temperature T within the differential, we get the necessary condition of equilibrium:

$$dU - TdS = d(U - TS) = 0 \quad (4.12)$$

The condition of equilibrium formulated in (4.12) for a constant temperature and constant volume system can be considered in the following way. The equilibrium value of the unconstrained internal variable in a system in diathermal contact with a thermostat *minimizes the function* $U - TS$ over the manifold of constrained equilibrium states for which the temperature of the system is identical to that of the thermostat. Again, we do not need *any data of the thermostat* except for the constant temperature. We can state that the function $U - TS$ is convenient to characterize this kind of equilibrium. This function is called the *free energy*² and is denoted by F .

$$F = U - TS \quad (4.13)$$

By substituting (2.22) as the differential of U and writing the differential of the product TS in two terms, we can write the total differential of F as follows:

$$dF = TdS - PdV + \sum_{i=1}^K \mu_i dn_i - TdS - SdT \quad (4.14)$$

Omitting the terms TdS and $-TdS$ yields the compact form of the total differential:

$$dF = -SdT - PdV + \sum_{i=1}^K \mu_i dn_i \quad (4.15)$$

²The name comes from the German *freie Energie* (free energy). It also has another name, *Helmholtz potential*, to honor Hermann Ludwig Ferdinand von Helmholtz (1821–1894), a German physician and physicist. Apart from F , it is denoted sometimes by A , the first letter of the German word *Arbeit* = work, referring to the available useful work of a system.

As both U and S are state functions, $U - TS$ is also a state function. From $F(T, V, \mathbf{n})$, we can easily calculate the energy function $U(S, V, \mathbf{n})$. Thus, the equation above is a differential fundamental equation whose finite equivalent is

$$F = F(T, V, \mathbf{n}) \quad (4.16)$$

This is in accordance with the statement in constant temperature and constant volume systems using the minimum of free energy as necessary criterion of equilibrium. Note that the independent variable of the free energy function in the fundamental equation is temperature instead of entropy.

4.3 Equilibrium in Constant Temperature and Constant Pressure Systems: The Gibbs Potential

Constant temperature and constant pressure can be maintained in a system having diathermal and flexible walls, if it is in contact with a reservoir whose temperature and pressure are kept constant. To characterize equilibrium within these conditions, let us choose a rigid, impermeable container at constant entropy comprising the reservoir and the inner system. Thus, the condition of equilibrium in this overall system is the minimum of energy.

The total energy is again the sum of the energy of the inner system U and that of the reservoir U^r (Fig. 4.3). This time, the inner system is closed (impermeable), but it can

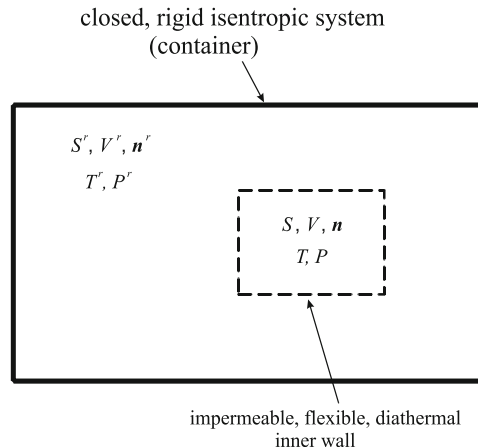

Fig. 4.3 Arrangement and notation to calculate the equilibrium state of an isentropic system in a thermostat and manostat. The overall system is isentropic, flexible, and impermeable. The wall separating the inner subsystem (delimited by dashed lines) is diathermal and flexible, so that the temperature T in the inner system is always identical to the constant temperature T^r of the container and the pressure P is also identical to that of the reservoir P^r

exchange energy with the reservoir in the form of heat and volume work, so the energy of the reservoir can be changed by these two effects:

$$dU^r = T^r dS^r - P^r dV^r \quad (4.17)$$

The overall system is rigid, closed, and isentropic, so that both its entropy and volume are constant, resulting in the identities $dS = -dS^r$ and $dV = -dV^r$. Thus, the differential of the total energy can be written as follows:

$$d(U + U^r) = dU + T^r dS^r - P^r dV^r = dU - T^r dS + P^r dV = 0 \quad (4.18)$$

As both temperature and pressure are identical in the inner system and the reservoir, we can substitute T and P in place of T^r and P^r . The constants T and P can be included within the differential, yielding

$$dU - TdS + PdV = d(U - TS + PV) = 0 \quad (4.19)$$

This result suggests that the minimization of the energy in the overall system is equivalent to the minimization of the function $U - TS + PV$ in the inner system of constant pressure and temperature. This function is usually denoted by G , but it has several different names.³ In this book, we shall call it *Gibbs potential*. The equation specifying this function

$$G = G(T, P, \mathbf{n}) \quad (4.20)$$

is also a fundamental equation. The corresponding differential fundamental equation – the total differential of the function $G(T, P, \mathbf{n})$ – can be derived from the definition $U - TS + PV$:

$$dG = TdS - PdV + \sum_{i=1}^K \mu_i dn_i - TdS - SdT + PdV + VdP \quad (4.21)$$

Omitting terms that cancel yields the compact form:

$$dG = -SdT + VdP + \sum_{i=1}^K \mu_i dn_i \quad (4.22)$$

³The name *free enthalpy* (rarely used in English) can be derived from enthalpy the same way as free energy is derived from energy. (See footnote 2 of this Chapter.) Usual names are *Gibbs function*, *Gibbs energy*, and *Gibbs potential* to honor Josiah Willard Gibbs (1839–1903), an American physicist who had a significant contribution to the development of thermodynamics. The alternative name *Gibbs free energy* is rarely used to avoid confusion with the (Helmholtz) free energy F .

4.4 Summary of the Equilibrium Conditions: Properties of the Energy-like Potential Functions

We have seen in the previous sections that the condition of equilibrium that follows from the postulates of thermodynamics can mathematically be treated in a number of ways. In many simple systems, the identity of the relevant intensive variables of the subsystems is sufficient to apply as equilibrium condition. This means that intensive quantities of a nonconstrained interaction are identical in the subsystems denoted by the subscript j which participate in the particular interaction. For different interactions, we can write the following identities.

$$\text{Thermal equilibrium : } T_j \equiv T, \forall j \quad (4.23)$$

$$\text{Mechanical equilibrium : } P_j \equiv P, \forall j \quad (4.24)$$

$$\text{Chemical equilibrium : } \mu_{ij} \equiv \mu_i, \forall j \quad (4.25)$$

Note that, while it is one single temperature and one single pressure that characterize the thermal and the mechanical equilibrium of the constituent subsystems, the condition of chemical equilibrium is the identity of the chemical potential of *every single* component which can freely move between the subsystems.

As we shall see later, identity of the intensive parameters does not always provide a useful result concerning equilibrium. In isolated systems, we may rely on the general criterion of entropy maximum formulated in Postulate 2, or, within different conditions, use the minimum of other *thermodynamic potentials* introduced in the previous sections, such as U , H , F , or G . Let us summarize these conditions in the following table.

Table 4.1 Equilibrium condition in closed systems within different conditions formulated using extrema of thermodynamic potential functions

Constant parameters	Equilibrium condition	Equation for the necessary condition of equilibrium	Stability condition
U and V	Maximum of $S(U, V, \mathbf{n})$	$dS = \frac{1}{T}dU + \frac{P}{T}dV - \sum_{i=1}^K \frac{\mu_i}{T}dn_i = 0$	$d^2S < 0$
S and V	Minimum of $U(S, V, \mathbf{n})$	$dU = TdS - PdV + \sum_{i=1}^K \mu_i dn_i = 0$	$d^2U > 0$
S and P	Minimum of $H(S, P, \mathbf{n})$	$dH = TdS + VdP + \sum_{i=1}^K \mu_i dn_i = 0$	$d^2H > 0$
T and V	Minimum of $F(T, V, \mathbf{n})$	$dF = -SdT - PdV + \sum_{i=1}^K \mu_i dn_i = 0$	$d^2F > 0$
T and P	Minimum of $G(T, P, \mathbf{n})$	$dG = -SdT + VdP + \sum_{i=1}^K \mu_i dn_i = 0$	$d^2G > 0$

By observing the table, we can compare different potential functions. All variables of $U(S, V, \mathbf{n})$ are extensive; thus, it is appropriate to use it for the characterization of equilibrium if extensive variables (S, V and \mathbf{n}) are constant. In case of a constant partial derivative of energy with respect to one of the extensive variables, the appropriate function to characterize equilibrium is the one which has the corresponding intensive variable instead of the extensive one. This can be obtained from the $U(S, V, \mathbf{n})$ function using *partial Legendre transformations*. Details of this transformation and the transformed functions are discussed in the Appendix.

The new variables obtained by the Legendre transformations along with the total differentials of the corresponding new functions can be remembered conveniently, even without knowing the mathematical technique of the transformation. By changing one of the extensive variables of the function $U(S, V, \mathbf{n})$, the new intensive variable will be the one which is the derivative of the U function with respect to the original extensive variable in the total differential of the U function, i.e., the coefficient of the increment of the original variable. In the total differential of the Legendre transform, variables in the coefficient and the increment are interchanged and the product changes sign. Following this rule, after the transformation concerning the variable S and its derivative T , this latter will be the new variable, and $-SdT$ is to be written in the total differential in place of $+TdS$.

Once the total differential is formulated, it is easy to identify the derivatives of the functions $H(S, P, \mathbf{n})$, $F(T, V, \mathbf{n})$, and $G(T, P, \mathbf{n})$ as the factors of the corresponding increments. There is a list of these derivatives below.

Derivatives of the function $H(S, P, \mathbf{n})$:

$$\left(\frac{\partial H}{\partial S}\right)_{P, \mathbf{n}} = T \qquad \left(\frac{\partial H}{\partial P}\right)_{S, \mathbf{n}} = V \qquad \left(\frac{\partial H}{\partial n_i}\right)_{S, P, n_j \neq i} = \mu_i$$

Derivatives of the function $F(T, V, \mathbf{n})$:

$$\left(\frac{\partial F}{\partial T}\right)_{V, \mathbf{n}} = -S \qquad \left(\frac{\partial F}{\partial V}\right)_{T, \mathbf{n}} = -P \qquad \left(\frac{\partial F}{\partial n_i}\right)_{T, V, n_j \neq i} = \mu_i$$

Derivatives of the function $G(T, P, \mathbf{n})$:

$$\left(\frac{\partial G}{\partial T}\right)_{P, \mathbf{n}} = -S \qquad \left(\frac{\partial G}{\partial P}\right)_{T, \mathbf{n}} = V \qquad \left(\frac{\partial G}{\partial n_i}\right)_{T, P, n_j \neq i} = \mu_i$$

All derivatives are necessarily functions of the same variables as the potential functions from which they are derived. Accordingly, $\mu_i(S, P, \mathbf{n})$ is derived from H , $\mu_i(T, V, \mathbf{n})$ from F , and $\mu_i(T, P, \mathbf{n})$ from G . The values of chemical potential that can be calculated from these functions are the same as those calculated from the function $\mu_i(S, V, \mathbf{n})$, which is introduced in (2.21) as the derivative of the function U , but the functions themselves are different. The choice of the appropriate μ_i function depends on the conditions of the thermodynamic system whose equilibrium we want to describe.

4.4.1 Calculation of Heat and Work from Thermodynamic Potential Functions

As we have seen, the work done (by the equilibrium system) can be obtained from the definition (2.2) by integrating $-PdV$. Similarly, based on (2.20) and (2.22), the heat absorbed can be calculated by integrating the term TdS . Both terms PdV and TdS occur a couple of times in the total differentials of Table 4.1. Within conditions where all the increments but dV or dS are zero (i.e., the corresponding variables are constant), the change of the potential function provides directly the work or heat.

It is obvious, for example, that the total differential (2.22) of U at constant volume and composition reduces to $(dU)_{V,n} = TdS$, while at constant entropy and composition, it is $(dU)_{S,n} = -PdV$. Similarly, from (4.7) at constant pressure and composition $(dH)_{P,n} = TdS$ and from (4.15) at constant temperature and composition $(dF)_{T,n} = -PdV$.

There are conditions where volume work or heat cannot be given directly by the change of a potential function, but its calculation is still relatively simple. An example is the calculation of heat at constant temperature, when the constant T can be factored out from the integration. The integral for finite changes then yields $T\Delta S$ as a result of multiplying the integral of dS (i.e., ΔS) by the constant T . The product $T\Delta S$ at constant temperature can also be written as $\Delta(TS)$, which is $\Delta U - \Delta F$. Therefore, constant temperature heat can be calculated from the differences of the potential functions U and F . In a similar way, the expression of constant pressure work can be calculated as $-P\Delta V$, or, based on the definition (4.5) of enthalpy, in an alternative form as $\Delta U - \Delta H$. Calculations of work and heat as described are summarized in Table 4.2.

It is readily seen from the table why the thermodynamic potential U is also called as *adiabatic work*. (An isentropic process of a simple system is equivalent to the change in an adiabatic system.) In a similar manner, H is also called *isobaric heat*. Special conditions seen in the table are used not only for the calculation of work or heat, but also for the determination of the potential functions, thus the fundamental equations, of individual systems (materials) by measuring work or heat or both. We know that the change of a state function is independent of the way we change the state of the system; it only depends on the initial and final state. Consequently, we can calculate work or heat for arbitrary processes using any combination of procedures included in the table; the only important thing is to start from the same initial state and arrive in the same final state.

Table 4.2 Calculation of volume work and heat in closed, chemically inert systems within different conditions expressed as changes of potential functions or simple differences

Process	Condition	Work	Heat
Isentropic	$dS = 0$	ΔU	0
Isobaric	$dP = 0$	$-P\Delta V = -\Delta(PV) = \Delta U - \Delta H$	ΔH
Isothermal	$dT = 0$	ΔF	$T\Delta S = \Delta(TS) = \Delta U - \Delta F$
Isochoric	$dV = 0$	0	ΔU

4.4.2 Calculation of Entropy and Energy-like Functions from Measurable Quantities

We have seen in Sect. 2.2.1 that changes in internal energy can be determined by measuring work in adiabatic systems. It is clear from the postulates that entropy is a unique function; not only its changes but also its absolute value is well determined. However, we do not know anything about how to *measure* entropy. As it is mentioned before, fundamental equations can only rarely be determined in a closed form, so they are to be determined mostly experimentally. These experiments should be done relatively easily, so that simple measurable quantities are to be determined. Before going into details of calculations of potential functions from experiments, let us explore these easily measurable quantities.

Based on the expressions of heat in Table 4.2, we can define measurable quantities related to heat transfer. The *molar heat capacity at constant pressure* is defined as follows:

$$c_P \equiv \frac{1}{n} \left(\frac{\partial Q}{\partial T} \right)_{P,n} = \frac{1}{n} \left(\frac{\partial H}{\partial T} \right)_{P,n} \quad (4.26)$$

In a similar way, we can define the *molar heat capacity at constant volume*:

$$c_V \equiv \frac{1}{n} \left(\frac{\partial Q}{\partial T} \right)_{V,n} = \frac{1}{n} \left(\frac{\partial U}{\partial T} \right)_{V,n} \quad (4.27)$$

In the above definitions, $(dQ)_{V,n} = T(dS)_{V,n}$ and $(dQ)_{P,n} = T(dS)_{P,n}$ are the heat absorbed by the system, which is a state function. To determine the heat capacity, heat absorbed by the system within the prescribed conditions should be measured, along with the change in temperature. In a sufficiently small temperature region, the derivatives with respect to temperature change only slightly and can be neglected; thus, the ratio of the absorbed heat to the temperature change provides the derivative itself. By reformulating the partial differentials according to the relations $(dQ)_{V,n} = T(dS)_{V,n}$ and $(dQ)_{P,n} = T(dS)_{P,n}$, molar heat capacities can be given in terms of the entropy function:

$$c_P \equiv \frac{T}{n} \left(\frac{\partial S}{\partial T} \right)_{P,n} \quad (4.28)$$

$$c_V \equiv \frac{T}{n} \left(\frac{\partial S}{\partial T} \right)_{V,n} \quad (4.29)$$

The *coefficient of thermal expansion* (also called as cubic expansion coefficient) is defined as follows:

$$\alpha \equiv \frac{1}{V} \left(\frac{\partial V}{\partial T} \right)_{P,n} \quad (4.30)$$

To determine this quantity, volume must be measured at constant pressure as a function of temperature.

The *isothermal compressibility* is defined as follows:

$$\kappa_T \equiv -\frac{1}{V} \left(\frac{\partial V}{\partial P} \right)_{T,n} \quad (4.31)$$

It can be determined from measurements of volume at constant temperature as a function of pressure.

We know from Postulate 1 that the number of degrees of freedom in simple systems is $K + 2$. If the composition of a system does not change – i.e., the ratio of the amounts of substances n_1, n_2, \dots, n_K is constant, it is enough to specify the sum of the amounts of substances of all chemical components to determine the extent of the system. Thus, to determine the actual state of the system, it is enough to know three independent quantities defined above. From the definitions, we can easily see that the measurable quantities c_P , α , and κ_T are easy to express as second partial derivatives of thermodynamic potential functions. The derivatives in the definitions of these quantities are all functions of P , T , and \mathbf{n} , which are the natural variables of the G function – i.e., the variables in the G function which is given in a fundamental equation. The first partial derivatives of this function are

$$V = \left(\frac{\partial G}{\partial P} \right)_{T,n} \quad \text{and} \quad -S = \left(\frac{\partial G}{\partial T} \right)_{P,n}$$

from which it easily follows that

$$c_P \equiv \frac{T}{n} \left(\frac{\partial S}{\partial T} \right)_{P,n} = -\frac{T}{n} \left(\frac{\partial^2 G}{\partial T^2} \right)_{P,n} \quad (4.32)$$

$$\alpha \equiv \frac{1}{V} \left(\frac{\partial V}{\partial T} \right)_{P,n} = \frac{1}{V} \left(\frac{\partial^2 G}{\partial T \partial P} \right)_n \quad (4.33)$$

$$\kappa_T \equiv -\frac{1}{V} \left(\frac{\partial V}{\partial P} \right)_{T,n} = -\frac{1}{V} \left(\frac{\partial^2 G}{\partial P^2} \right)_{T,n} \quad (4.34)$$

Accordingly, the second derivatives can be written as $-n c_P/T$, αV , and $-\kappa_T V$, from which the function $G(T, P, \mathbf{n})$ can be calculated by integration.

By making use of relations between thermodynamic potentials, entropy can also be calculated from c_P and α , as a function of temperature and pressure. To get this function, let us start from the formal differential valid for closed systems, i.e., omitting all the terms containing $dn_i = 0$:

$$dS = \left(\frac{\partial S}{\partial T} \right)_{P,n} dT + \left(\frac{\partial S}{\partial P} \right)_{T,n} dP \quad (4.35)$$

From the definition (4.28) it follows that

$$\left(\frac{\partial S}{\partial T}\right)_{P,\mathbf{n}} = \frac{n c_P}{T} \quad (4.36)$$

The coefficient of thermal expansion α – as shown above – is the second partial derivative of the function $G(T, P, \mathbf{n})$, which is derived first with respect to P and then with respect to T . According to Young's theorem, the mixed second partial derivatives of multivariable functions are equal, irrespective of the order of derivation. (In thermodynamics, identities based on this theorem are called *Maxwell relations*. They are useful relations which often help to solve thermodynamic problems. More details can be found in Appendix 1.) Using this theorem, we can write as follows:

$$\left(\frac{\partial V}{\partial T}\right)_{P,\mathbf{n}} = \left(\frac{\partial^2 G}{\partial T \partial P}\right)_{\mathbf{n}} \equiv \left(\frac{\partial^2 G}{\partial P \partial T}\right)_{\mathbf{n}} = -\left(\frac{\partial S}{\partial P}\right)_{T,\mathbf{n}} \quad (4.37)$$

By combining this with the definition (4.30) of the thermal expansion α , we get:

$$\left(\frac{\partial S}{\partial P}\right)_{T,\mathbf{n}} = -\alpha V \quad (4.38)$$

By substituting the two derivatives into (4.35), we get the differential equation:

$$dS = \frac{n c_P}{T} dT - \alpha V dP \quad (4.39)$$

The entropy function can be determined by integrating this equation:

$$S_1(T_1, P_1, \mathbf{n}) = S_0(T_0, P_0, \mathbf{n}) + \int_{P_0, T_0}^{P_1, T_1} \left(\frac{n c_P}{T} dT - \alpha V dP\right) \quad (4.40)$$

As $S(T, P, \mathbf{n})$ is a state function, the integration can be done in the following way:

$$S_1(T_1, P_1, \mathbf{n}) = S_0(T_0, P_0, \mathbf{n}) + \int_{T_0, P_0}^{T_1, P_0} \frac{n c_P}{T} dT - \int_{T_1, P_0}^{T_1, P_1} \alpha V dP \quad (4.41)$$

We know from Postulate 4 that the constant at $T_0 = 0 \text{ K}$ is zero in any equilibrium system. Consequently, if we know the heat capacity as a function of temperature from 0 K up to T_1 , and the coefficient of thermal expansion in the pressure range $P_0 - P_1$, entropy can be calculated as a function of temperature and pressure from measured data.

It is easy to adapt (4.41) for the calculation of *entropy changes* with the change of temperature or pressure. At constant pressure:

$$S_1(T_1, P_0, \mathbf{n}) = S_0(T_0, P_0, \mathbf{n}) + n \int_{T_0}^{T_1} \frac{c_P}{T} dT \quad (4.42)$$

At constant temperature:

$$S_1(T_0, P_1, \mathbf{n}) = S_0(T_0, P_0, \mathbf{n}) + \int_{P_0}^{P_1} \alpha V dP \quad (4.43)$$

Let us apply the latter for an ideal gas, using the equation of state $PV = nRT$, from which it follows that $\alpha = 1/T$ and $V = nRT/P$. By substituting the product of the two, nR/P , we get:

$$S_1(T_0, P_1, \mathbf{n}) = S_0(T_0, P_0, \mathbf{n}) + nR \int_{P_0}^{P_1} \frac{1}{P} dP = S_0(T_0, P_0, \mathbf{n}) + nR \ln \frac{P_1}{P_0} \quad (4.44)$$

It is worth noting that, if we need c_V instead of c_P , we can obtain it using the above results along with some mathematical relations between derivatives. Let us write the derivative $(\partial S/\partial T)_V$ in the definition (4.29) of c_V , using (4.39) and the chain rule:

$$\left(\frac{\partial S}{\partial T}\right)_V = \frac{nc_P}{T} \left(\frac{\partial T}{\partial T}\right)_V - \alpha V \left(\frac{\partial P}{\partial T}\right)_V \quad (4.45)$$

As the derivative $(\partial T/\partial T)_V$ is unit, the result can be written simply as follows:

$$c_V = \frac{T}{n} \left(\frac{\partial S}{\partial T}\right)_V = c_P - \frac{\alpha TV}{n} \left(\frac{\partial P}{\partial T}\right)_V \quad (4.46)$$

This result is usually rewritten as the difference of the two heat capacities:

$$c_P - c_V = \frac{\alpha TV}{n} \left(\frac{\partial P}{\partial T}\right)_V \quad (4.47)$$

This is important as a commonly used *compatibility condition* of equations of state. The equation is valid for any substances or systems; thus, any equation of state should fulfill this condition. The derivative $(\partial P/\partial T)_V$ is not an easily measurable quantity, but we can express it with other derivatives which determine easily measurable quantities, using the chain rule:

$$\left(\frac{\partial P}{\partial T}\right)_V = -\left(\frac{\partial V}{\partial T}\right)_P / \left(\frac{\partial V}{\partial P}\right)_T = -\frac{V\alpha}{-V\kappa_T} = \frac{\alpha}{\kappa_T} \quad (4.48)$$

Substituting this into (4.47) yields an expression with measurable quantities only:

$$c_P - c_V = \frac{\alpha^2 TV}{n\kappa_T} \quad (4.49)$$

Let us calculate the relevant quantities for an ideal gas using the equation of state $PV = nRT$:

$$\alpha = \frac{1}{V} \left(\frac{\partial V}{\partial T} \right)_P = \frac{nR}{PV} = \frac{1}{T} \quad \kappa_T = -\frac{1}{V} \left(\frac{\partial V}{\partial P} \right)_T = \frac{nRT}{P^2 V} = \frac{1}{P} \quad (4.50)$$

Upon substitution of these into (4.49) and using the equation of state again:

$$c_P - c_V = \frac{1}{T^2} \frac{TV P}{n} = \frac{PV}{nT} = R \quad (4.51)$$

It is important to emphasize that the relation $c_P - c_V = R$ holds only for an *ideal gas*, while (4.49) is valid for all substances.

4.4.3 Calculation of Thermodynamic Quantities from the Fundamental Equation

It has been mentioned several times in previous chapters that the knowledge of the fundamental equation is sufficient to specify any equilibrium state of the system. As an example, let us take the fundamental equation

$$G = G(T, P, \mathbf{n}) \quad (4.52)$$

to demonstrate that every thermodynamic property can be calculated from it, in any state of the system.

The independent variables of the function G are temperature, pressure, and the composition vector $\mathbf{n} = (n_1, n_2, \dots, n_K)$. Therefore, we can expect that the function specified by the fundamental equation provides all other thermodynamic quantities at any values of the variables T , P , and \mathbf{n} . As we shall see, to get these quantities, all we need are the derivatives of the function $G(T, P, \mathbf{n})$ and the definition of the thermodynamic potentials H , F , and G .

The entropy function $S(T, P, \mathbf{n})$ – according to (4.22) – is simply the derivative

$$S = - \left(\frac{\partial G}{\partial T} \right)_{P, \mathbf{n}} \quad (4.53)$$

Volume can be calculated from the function $V(T, P, \mathbf{n})$ – another derivative of the function G :

$$V = \left(\frac{\partial G}{\partial P} \right)_{T, \mathbf{n}} \quad (4.54)$$

By knowing S and V , the function $U(T, P, \mathbf{n})$ follows from $G = U + PV - TS$:

$$U = G - P \left(\frac{\partial G}{\partial P} \right)_{T, \mathbf{n}} - T \left(\frac{\partial G}{\partial T} \right)_{P, \mathbf{n}} \quad (4.55)$$

In a similar way, we can get the functions H and F from the corresponding definitions of (4.5) and (4.13):

$$H = G - T \left(\frac{\partial G}{\partial T} \right)_{P, \mathbf{n}} \quad (4.56)$$

$$F = G - P \left(\frac{\partial G}{\partial P} \right)_{P, \mathbf{n}} \quad (4.57)$$

It follows from (4.22) that the chemical potential functions $\mu_i(T, P, \mathbf{n})$ are also derivatives of the function $G(T, P, \mathbf{n})$:

$$\mu_i = \left(\frac{\partial G}{\partial n_i} \right)_{T, P, n_j \neq i} \quad (4.58)$$

We can also calculate measurable quantities (α , κ_T , and c_P) as second partial derivatives of the function $G(T, P, \mathbf{n})$. (See (4.32), (4.33), and (4.34).)

Following the above example, we can calculate all thermodynamic quantities at any values of the independent variables in the fundamental equation also in case of knowing other fundamental equations.

4.5 Equations of State of Real Gases, Fluids and Solids

Due to the great diversity of materials, it is hard to find equations of state of general application, but there exist lots of empirical equations which provide good approximations to describe certain groups of substances in some temperature and pressure range. To describe gases, the simplest procedure is to keep the form of the ideal gas equation (2.39) by inserting a correction factor Z called *compression factor*.⁴ This factor can be calculated in the following way. Let us write the molar volume of an ideal gas using (2.39):

⁴ Z is also called *compressibility factor*, but it is easy to mistake for the compressibility defined in (4.31).

$$v_{\text{id}} = \frac{RT}{P} \quad (4.59)$$

By rearranging, this we get the identity for an ideal gas:

$$\frac{RT}{Pv_{\text{id}}} = 1 \quad (4.60)$$

Obviously, this is not valid for a real gas. Let us express the deviation from ideality in the form

$$Z = \frac{Pv}{RT} \quad (4.61)$$

which is the compression factor. Using this definition, the modified equations of state that describe the real gas can be written in the following forms:

$$v = \frac{ZRT}{P} \quad \text{and} \quad P = \frac{ZRT}{v} \quad (4.62)$$

This modification is apparently simple; the compression factor Z depends on pressure and temperature which is implicitly included in the formally simple equations. For actual calculations, we can find tables of the factor Z for different gases.

A widely used general equation for real gases is the *virial equation*, which is a kind of expansion. We can consider the mechanical equation of state of an ideal gas, $P/T=R/v$, as the first term of a Taylor series in terms of $1/v$; the series can be continued as follows:

$$\frac{P}{T} = \frac{R}{v} \left(1 + \frac{B}{v} + \frac{C}{v^2} + \dots \right) \quad (4.63)$$

By rearranging the equation, it is obvious that it was originally a polynomial of the variable $1/v$:

$$\frac{Pv}{RT} = 1 + \frac{B}{v} + \frac{C}{v^2} + \dots \quad (4.64)$$

We may note that it is the power series of the compression factor $Z = Pv/RT$, which sensitively indicates deviations from the ideal gas equation. (Its value for an ideal gas is 1.) This is the reason behind the use of the *virial equation*⁵ in the form of (4.64). In its alternative form

⁵The name of the *virial equation* and the *virial coefficients* comes from the Latin noun *vis* = force (whose stem can change to *vir*). It refers to the fact that the reason for deviations from the ideal gas equation is due to interaction forces between molecules.

$$P = \frac{RT}{v} \left(1 + \frac{B}{v} + \frac{C}{v^2} + \dots \right) \quad (4.65)$$

it is used to calculate the pressure as a function of temperature and volume. To calculate the molar volume as a function of pressure and temperature, another form is also used:

$$v = \frac{RT}{P} + B + C'P + \dots \quad (4.66)$$

This is also called as virial equation. The virial coefficient B is identical here with coefficient B in the expansion of the pressure, but C' is different from C . However, by knowing B and C , C' can be calculated. Coefficient B is called the *second virial coefficient*, while C is the *third virial coefficient*. (The “first virial coefficient” was the constant $A = RT/v$.) If a high precision of calculated thermodynamic data is desirable, higher virial coefficients D , E , etc., are also used. Obviously, we can achieve arbitrarily exact results by specifying the virial coefficients up to high enough degrees. Around ambient temperatures, the second virial coefficient is enough to get reasonably well approximations of calculated thermodynamic data.

The use of the virial equation is advantageous in thermodynamics for the coefficients in the expansion of the molar free energy f ,

$$f = f^{\text{id}} + RT \left(\frac{B}{v} + \frac{C}{2v^2} + \dots \right) \quad (4.67)$$

are identical with that of the coefficients of the virial equation (4.63). This can be proved easily by derivating the above function $f(T, v)$:

$$\left(\frac{\partial f}{\partial v} \right)_T = \left(\frac{\partial f^{\text{id}}}{\partial v} \right)_T + RT \left(-\frac{B}{v^2} - \frac{2C}{2v^3} + \dots \right) \quad (4.68)$$

The derivative of the function f with respect to v is $-P$. The pressure of the ideal gas (first term on the right-hand side) can be written as $-RT/v$. Substituting these into the above equation yields

$$-P = -\frac{RT}{v} - \frac{RT}{v} \left(\frac{B}{v} + \frac{C}{v^2} + \dots \right) \quad (4.69)$$

which is equivalent to (4.65). As (4.67) is a fundamental equation, all thermodynamic quantities can be calculated from it, as a function of volume and temperature, if we know the virial coefficients.

It is important to note that the virial coefficients are *temperature dependent*, which reduces their practical importance.

Apart from the van der Waals equation of state discussed in Sect. 2.2.7 and the virial equation, a number of empirical equations of state are in practical use for different technical purposes. Many of them resemble the van der Waals equation with constants of varying number and role.

Constants of the van der Waals equation and the virial equation (a , b , B , and C), as well as constants of other types of equations of state are different for every substances. The constants a and b of the van der Waals equation are also dependent on pressure; thus, they can only be used in a limited pressure range, even for the same substance. There was always an effort to find a *general* equation of state which could relate the constants of different materials quantitatively. Statistical thermodynamics provides an answer for the problem, but there was also an earlier solution based on macroscopic measurements. As discussed in Sect. 7.2, there exists a temperature for each substance above which no liquid but only gas exists. This temperature T_{cr} is called the *critical temperature*, the corresponding pressure P_{cr} is the *critical pressure*, and the molar volume v_{cr} is the *critical molar volume*. When comparing the experimentally determined critical data, it was found that the critical compression coefficient $Z_{\text{cr}} = P_{\text{cr}}v_{\text{cr}}/RT_{\text{cr}}$ is the same for every substances to a good approximation. Apart from values as 0.23 for water or 0.24 for ammonia (and similar values for rather polar substances), this common compression coefficient is around 0.27. This can be interpreted that the critical pressure P_{cr} , the critical temperature T_{cr} , and the critical molar volume v_{cr} are not independent of each other; from two of them we can determine the third one. As a consequence of this, a universal equation of state can be formulated using the so-called *reduced variables* and two parameters only. Let us define the reduced variables as follows:

$$P_r = \frac{P}{P_{\text{cr}}} \quad T_r = \frac{T}{T_{\text{cr}}} \quad v_r = \frac{v}{v_{\text{cr}}} \quad (4.70)$$

The two parameters can be the critical pressure and the critical temperature from which the critical molar volume can be calculated. Using these variables, the general equation of state can be written as $P_r v_r = RT_r$. This empirical fact is referred to as the *law of corresponding states*.

The reason behind this law can be understood from a molecular point of view. Molecules experience short-range repulsion depending on their diameter, and long-range attraction depending on the inverse of the sixth power of intermolecular distance. Thus, the two parameters at molecular level are the diameter of the molecules and the constant in the attractive force which is the factor of the inverse sixth power of intermolecular distance. These two “degrees of freedom” manifest in the macroscopic description as well. In fact, the molecular structure also plays a role in their interactions, which makes this simple picture somewhat more complicated and results in the fact that the law of corresponding states is only approximately valid.

It is interesting to combine the two-parameter van der Waals equation with the law of corresponding states which also contains two material-dependent parameters: the critical temperature and pressure. We can write the van der Waals equation using the reduced variables, and substitute for the critical values those calculated from the van der Waals equation written in terms of the constants a and b . We get the result (see Sect. 7.2):

$$P_r = \frac{8T_r}{3v_r - 1} - \frac{3}{v_r^2} \quad (4.71)$$

The above equation can be considered as a particular form of equation of state according to the law of corresponding states. Apart from the two substance-specific constants P_r and T_r , this equation is universal. We can say that it is an alternative of the two-parameter van der Waals equation of state with constants having more physical significance than the parameters a and b .

The thermodynamic behavior of *condensed matter* – liquids and solids – resembles one another, but it is largely different from that of gases. (The only exception is the near-critical fluid which resembles more of a gas.) Isothermal compressibility of a gas is nearly inversely proportional to the pressure. It is easy to show this for an ideal gas:

$$\kappa_T \equiv -\frac{1}{V} \left(\frac{\partial V}{\partial P} \right)_{T,n} = -\frac{P}{nRT} \frac{\partial}{\partial P} \left(\frac{nRT}{P} \right) = -P \left(\frac{\partial (1/P)}{\partial P} \right)_{T,n} = \frac{1}{P} \quad (4.72)$$

The compressibility of condensed matter is much smaller than in a gas and it depends only slightly on pressure. It can be considered constant to a good approximation:

$$-\frac{1}{V} \left(\frac{\partial V}{\partial P} \right)_{T,n} = \kappa_T = \text{constant} \quad (4.73)$$

By integrating the above equation we get:

$$V = V_0 e^{-\kappa_T P} \quad (4.74)$$

(This can be demonstrated by derivation of the above function V with respect to P ; we get back $-\kappa_T V$.) The constant V_0 is the limiting value at zero pressure, at the given temperature. At pressures not much different from the atmospheric pressure, we can make use of the relation $\kappa_T P \ll 1$ and replace the exponential with the first-order Taylor polynomial (as higher order terms are negligible). The resulting equation of state is

$$v = v_0(1 - \kappa_T P) \quad (4.75)$$

At constant temperature and composition, the chemical potential as a function of pressure can be obtained by integrating the expression $v dP$ (see (6.31)):

$$\mu(T, P) = \mu_0 + \int_0^P v dP \quad (4.76)$$

Here, μ_0 is the limiting value of the chemical potential at zero pressure, at the given temperature. Substituting the above derived molar volume and performing the integration yields:

$$\mu = \mu_0 + v_0 \int_0^P (1 - \kappa_T P) dP = \mu_0 + v_0 P \left(1 - \frac{1}{2} \kappa_T P \right) \quad (4.77)$$

Here, v_0 is the limiting value of the molar volume at zero pressure, at the given temperature. The compressibility of liquids and solids is usually so small that the term $\kappa_T P$ can be neglected compared to 1.

The molar free energy can be calculated using the relation $f = \mu - Pv$. Substituting the molar volume (4.75) into this expression yields:

$$f = \mu_0 + \frac{1}{2} \kappa_T P^2 v_0 \quad (4.78)$$

Again, the second term can usually be neglected.

The temperature dependence of the molar volume can be calculated as

$$\frac{dv_0}{dT} = \alpha_0 v_0 \quad (4.79)$$

where α_0 is the limiting value of the coefficient of thermal expansion at zero pressure. For most condensed systems – except for liquids near the critical point – the coefficient of thermal expansion α is rather small, the molar volume v_0 can be considered as independent of temperature to a good approximation. Excluding near-critical liquids, the molar volume of condensed systems is in the order of magnitude of 10 – 100 cm³/mol. At atmospheric pressures, the product Pv calculated from this yields an energy of 1 – 10 J/mol, which can be neglected compared to the chemical potential and molar free energy which are larger by several orders of magnitude. As a result, in condensed systems, there is only a negligibly slight difference between the Gibbs potential and free energy, and similarly between enthalpy and internal energy.

The derivative of the chemical potential with respect to temperature yields the molar entropy. By derivation of the right-hand side of (4.77), we get:

$$s = -\frac{d\mu_0}{dT} - \alpha P v_0 \left(1 - \frac{1}{2} \kappa_T P\right) \quad (4.80)$$

The term $\frac{1}{2} \kappa_T P$ may again be neglected at not too high pressures; thus, we get the following good approximation for the molar entropy:

$$s = -\frac{d\mu_0}{dT} - \alpha P v_0 \quad (4.81)$$

The molar enthalpy can be calculated using the relation $h = \mu + Ts$. Substituting μ from (4.77) into this expression yields:

$$h = \mu_0 - T \frac{d\mu_0}{dT} + P v_0 \left(1 - \frac{1}{2} \kappa_T P - \alpha T\right) \quad (4.82)$$

According to previous reasoning, the last term multiplied by $P v_0$ can be neglected also in this formula.

The above results are universally valid for condensed systems, but parameters in the formulae (α , κ_T , v_0 , μ_0 , etc.) are of course material specific. Equations of state or fundamental equations valid for actual substances or groups of substances can be obtained using statistical thermodynamic calculations or numerical simulations.

4.5.1 Chemical Potential and Fugacity of a Real Gas

In this section, we shall introduce a quantity which is not used in equations of state of real gases that serve direct practical applications, but in fundamental equations based on the Gibbs potential. The introduction of this quantity results in a formal simplification only, similarly to the case of the compression coefficient Z . To start with the introduction, let us write the total differential of the Gibbs potential, (4.22), for a *single component system* (i.e., a *pure component*):

$$dG = -SdT + VdP + \mu dn \quad (4.83)$$

It follows that the chemical potential of a pure substance is given by:

$$\mu = \left(\frac{\partial G}{\partial n} \right)_{T,P} \quad (4.84)$$

The extensive Gibbs potential G can be calculated from the molar Gibbs potential g as the product $G = ng$, which leads to the result

$$\mu = \left(\frac{\partial [gn]}{\partial n} \right)_{T,P} = g \quad (4.85)$$

i.e., the chemical potential of a pure substance is identical to its molar Gibbs potential. Consequently, we can formulate the G -based fundamental equation in the following form (referring to 1 mol, we can omit the term multiplied by $dn = 0$):

$$d\mu = -sdT + vdP \quad (4.86)$$

If we restrict this equation to constant temperature, the first term becomes zero and the expression for $d\mu$ contains only vdP . The molar volume v of an ideal gas can be written as $v = RT/P$ so that, at constant temperature

$$d\mu = RT \frac{1}{P} dP = RT d \ln P \quad (4.87)$$

This equation is of course not valid for real gases, as their molar volume $v \neq RT/P$. This is the point to introduce the *fugacity* f which is written in place of the pressure P resulting in a correct expression for $d\mu$ even in a real gas:

$$d\mu = vdP = RT d \ln f \quad (4.88)$$

The above equation can be rearranged in the form

$$RT \left(\frac{\partial \ln f}{\partial P} \right)_T = v \quad (4.89)$$

Let us subtract from this equation the equivalent equation valid for an ideal gas,

$$RT \left(\frac{\partial \ln P}{\partial P} \right)_T = \frac{RT}{P} \quad (4.90)$$

which yields the following equation:

$$RT \left[\left(\frac{\partial \ln f}{\partial P} \right)_T - \left(\frac{\partial \ln P}{\partial P} \right)_T \right] = v - \frac{RT}{P} \quad (4.91)$$

We can exchange the order of operations within the square brackets; perform subtraction of P from f first and derivation next. Writing the ratio of arguments in place of the differences of logarithms, we get the following equation:

$$RT \left(\frac{\partial \ln [f/P]}{\partial P} \right)_T = v - \frac{RT}{P} \quad (4.92)$$

Let us introduce the quantity $\varphi = f/P$ (referred to as the *fugacity coefficient*) and rewrite the equation accordingly:

$$RT \left(\frac{\partial \ln \varphi}{\partial P} \right)_T = v - \frac{RT}{P} \quad (4.93)$$

Let us make use of the fact that the properties of a real gas become that of an ideal gas at the limit of zero pressure and integrate this equation from zero to the actual pressure P :

$$RT \int_0^P d \ln \varphi = \int_0^P \left(v - \frac{RT}{p} \right) dp \quad (4.94)$$

At the pressure $P = 0$, $f = P$, thus $\varphi = 1$, yielding an integral of the left side as $RT [\ln \varphi - \ln 1] = RT \ln \varphi$, from which we can write:

$$RT \ln \varphi = \int_0^P \left(v - \frac{RT}{p} \right) dp \quad (4.95)$$

The right side can also be integrated, as $v = RT/P$ at $P = 0$; thus, the integrand is always finite. Consequently, we can rewrite (4.88) in the following form:

$$d\mu = RT d \ln f = RT d \ln (\varphi P) \quad (4.96)$$

Seemingly, we have got a very simple equation; we only have to insert the fugacity coefficient φ into (4.87), valid for an ideal gas, to make it valid for real gases as well. However, we should keep in mind that the fugacity coefficient depends on pressure as described in (4.95), and, in addition, it depends on temperature as well. Thus, the simplification is only formal as we need the function $\varphi(P, T)$ to perform actual calculations. However, we may note that $\varphi(P, T)$ is a *state function* as it can be calculated using (4.95) by the integration of the difference of the state functions $v(P, T)$ and RT/P .

Fugacity is not really used for single component gases; it has originally been introduced to describe the thermodynamics of gas mixtures and it is still used for this purpose. We shall discuss this application in Sect. 6.3.1.

Problems

1. The fundamental equation of an ideal van der Waals fluid is given in (2.68):

$$s = s_0 + R \ln \frac{(v - b)(u + a/v)^c}{(v_0 - b)(u_0 + a/v_0)^c}$$

From Chap. 2 we know that a , b , and c are positive constants. On the basis of this equation, calculate the intensive quantities T and P as a function of u and v , and determine the molar heat capacity c_V . Show that, if $a \rightarrow 0$ and $v_0 \rightarrow 0$, the expression of the molar heat capacity can be simplified to the heat capacity of an ideal gas.

Solution: We can find the reciprocal of temperature and pressure as the derivatives of the entropy function (See Sect. 2.2.2.):

$$\frac{1}{T} = \frac{\partial s}{\partial u} = \frac{acR(v - v_0)}{(a + uv)(a + uv_0)}$$

$$\frac{P}{T} = \frac{\partial s}{\partial v} = R \left(\frac{1}{v - b} - \frac{ac}{av + uv^2} \right)$$

By calculating the reciprocal of these expressions, we get the desired functions:

$$T = \frac{(a + uv)(a + uv_0)}{acR(v - v_0)}$$

$$P = \frac{[uv^2 + a(bc + v - cv)](a + uv_0)}{acv(b - v)(v - v_0)}$$

From the temperature function, we can express the molar internal energy u :

$$u(T, v) = a(v - v_0) \frac{1 + \sqrt{1 + \frac{4cRTv_0}{a(v - v_0)}}}{2vv_0}$$

According to the definition in (4.27), the derivative of this function with respect to temperature yields the desired molar heat capacity at constant volume:

$$c_V = \frac{cR}{\sqrt{1 + \frac{4cRTv_0}{a(v-v_0)}}}$$

(As the energy function $u(T, v)$ already provides the *molar* energy, there is no need to divide the derivative by n .) It is easy to see that the limit of the above expression at $a \rightarrow 0$ and $v_0 \rightarrow 0$ results in cR , which is the heat capacity of an ideal gas (cf. Sect. 2.2.5.).

2. The fundamental equation of a particular system is the following:

$$U = \frac{\theta}{R^2} \cdot \frac{S^3}{nV}$$

(The constants θ and R are positive.) Calculate the thermodynamic potentials S , H , F , and G . Find the intensive parameters of the system, and express the heat capacities C_P and C_V , as well as the coefficient of thermal expansion α and the isothermal compressibility κ_T .

Solution: Let us find first the expressions for the intensive quantities T , P , and μ as the derivatives of the energy function:

$$T = \left(\frac{\partial U}{\partial S} \right)_{V, n} = \frac{3S^2\theta}{nR^2V}$$

$$P = - \left(\frac{\partial U}{\partial V} \right)_{S, n} = \frac{S^3\theta}{nR^2V^2}$$

$$\mu = \left(\frac{\partial U}{\partial S} \right)_{S, V} = \frac{S^3\theta}{n^2R^2V}$$

Let us find next the entropy-based fundamental equation by inverting the U function, which we can do rearranging the given equation for the U function:

$$S = \sqrt[3]{\frac{nR^2UV}{\theta}}$$

(Note that only the positive root has to be taken into account.)

We can calculate the thermodynamic potentials as functions of their natural variables by substituting the necessary expression derived above for the intensive variables into the entropy function, thus replacing an extensive variable in the

energy function by an intensive one. Using the definitions of the particular functions, we get the following results:

$$F(T, V, n) = U - TS = -\frac{2R}{3} \sqrt{\frac{T^3 nV}{3\theta}}$$

$$H(S, P, n) = U + PV = \frac{2}{R} \sqrt{\frac{S^3 P\theta}{n}}$$

$$G(T, P, n) = U - TS + PV = \frac{nR^2 T^3}{27P\theta}$$

The (extensive) heat capacities C_P and C_V can be derived from the potential functions H and U , according to (4.26) and (4.27):

$$C_P = \left(\frac{\partial H}{\partial T} \right)_{P,n} = \frac{2R^2 T^2}{9P\theta}$$

$$C_V = \left(\frac{\partial U}{\partial T} \right)_{V,n} = \frac{R}{2} \sqrt{\frac{nTV}{3\theta}}$$

By combining the equations obtained for T and P , after rearrangements and substitution, we can derive the function $V(T, P, n)$. Derivation of this function leads to the expressions of the coefficient of thermal expansion and the isothermal compressibility, according to (4.30) and (4.31):

$$\alpha = \frac{1}{V} \left(\frac{\partial V}{\partial T} \right)_{P,n} = \frac{3}{T} \quad (4.30)$$

$$\kappa_T = -\frac{1}{V} \left(\frac{\partial V}{\partial P} \right)_{T,n} = \frac{2}{P} \quad (4.31)$$

Further Reading

- Atkins P, de Paula J (2009) Physical chemistry, 9th edn. Oxford University Press, Oxford
- Callen HB (1985) Thermodynamics and an introduction to thermostatistics, 2nd edn. Wiley, New York
- Denbigh KG (1981) The principles of chemical equilibrium, 4th edn. Cambridge University Press, Cambridge
- Guggenheim EA (1985) Thermodynamics: an advanced treatment for chemists and physicists, 7th edn. North Holland, Amsterdam
- Moore WJ (1998) Physical chemistry, 4th edn. Prentice-Hall, Indianapolis, IN
- Silbey LJ, Alberty RA, Moungi GB (2004) Physical chemistry, 4th edn. Wiley, New York

Chapter 5

Thermodynamic Processes and Engines

The postulates of thermodynamics are valid for equilibrium states. Relations derived from the postulates are applicable for changes of states where, following the change (or release) of internal constraints, a new equilibrium is achieved. Quantities characterizing equilibrium states can be given as functions of state variables. According to Postulate 1, variables U , V , and \mathbf{n} completely determine the equilibrium state. Postulate 2 assigns the entropy function $S(U, V, \mathbf{n})$ to the equilibrium states. On the basis of this, we can refer to the coordinate space spanned by the variables U , V , and \mathbf{n} as a *thermodynamic configuration space* where the possible configurations (the equilibrium states of the composite systems) are determined by the values of the entropy function lying on a continuous surface we can call *state surface*. The graph of this function is a tridimensional surface that conforms Postulates 2 and 3 and their consequences; its constant-energy section is concave, while its constant-entropy section is convex (cf. Fig. 3.1).

It is important to know that nonequilibrium states cannot be represented in this space. Nonequilibrium states could only be represented in a space having much greater dimension. As mentioned in Chap. 2, macroscopic properties in equilibrium are time-independent average values of the system consisting of a very large number of particles. If there is no equilibrium, these averages (expectation values) do not exist, or are strongly time-dependent. This is the reason that only equilibrium systems can be represented in the thermodynamic configuration space and they always lie on the state surface determined by the fundamental equation $S = S(U, V, \mathbf{n})$. The first part of this chapter explores the consequences of this property.

5.1 Quasistatic, Reversible and Irreversible Processes

The equilibrium state is also called *static* state, using a Latin word of Greek origin. To move a system from an actual *static* state – let us denote the corresponding point on the $S(U, V, \mathbf{n})$ state surface by A – to another state C, some internal constraints should be changed. For example, we can initiate a state change by changing an

internal rigid wall to become flexible. If pressure was different in the two subsystems, the suddenly flexible wall begins to move, and there is no equilibrium within the parts of the system that are influenced by sudden changes during pressure equilibration.

However, we can also proceed so that the system does not directly go to state C from A, but successively to some intermediate points denoted by B_i . Accordingly, we can change the internal constraint (e.g., in this case, let the piston move only slightly) so that, after the first change of state, the next equilibrium state will be B_1 , then B_2 , etc., until it gradually reaches state C. It is obvious that placing the successive points B_i closer and closer to each other, we disturb the equilibrium states during the changes less and less. With arbitrarily dense division of the path from A to C, we allow only for arbitrarily small deviation from equilibrium. At the limiting case with infinitely dense division, the system is always on the state surface. (Of course, this cannot be realized in practice as no difference in pressure results in no change. But arbitrarily small finite changes – at least in principle – could be realized.) This approximation of a real change is called a *quasistatic*¹ process.

A quasistatic process can be realized in practice to a good approximation, provided that changes in the state of a large number of molecules are slow enough that the expectation value corresponding to a macroscopic quantity would exist and it would change more slowly than the recovery of an equilibrium distribution. In case of the example mentioned – the equilibration of pressure – the pressure suddenly drops near the moving wall, as molecules cannot follow this move instantaneously. Molecules are able to follow the displacement of the wall not faster than the speed of sound. During this procedure, shock waves can be formed which reflect from opposite walls and get damped within the system. Shock waves can also induce hydrodynamic flow, which also gets damped within the medium. The spread of shock waves is related to the velocity of sound in the medium, while hydrodynamic flow is related to viscosity. These two quantities determine the *relaxation time* of the system necessary to calm. The velocity of sound is several hundred m/s in a gas or liquid. This means that in liquids or near-atmospheric pressure gases the “void space” of the size of a few micrometers is replenished within about 10^{-5} s, and in a system of the extension of about 1 m, shock waves are reflected at least once from opposite walls within 10^{-3} – 10^{-2} s. Consequently, if a piston is moved not faster than $1 \mu\text{m}$ within 0.001 s, the system can relax and equilibrium states can be sustained during changes. $1 \mu\text{m}/0.001 \text{ s}$ is equivalent to 10^{-3} m/s, which practically ensures conditions for a quasistatic change. In practical devices, the speed of change is usually greater than this. Let us examine the consequences of deviations from the quasistatic change.

In the previous discussion, the example was the displacement of a piston in a cylinder. To get the maximum work from an expansion, we should gain the entire

¹The Greek word *στατικός* [statikos] means steady or standstill. The Latin comparative and conjunctive *quasi* is a compound word coined from *quam* and *si*, meaning “as if”, “approximately”, or “nearly”. In this context, quasistatic means “nearly equilibrium”.

energy change in the form of volume work. According to (2.22), it can be achieved in a closed system if the heat TdS is zero, i.e., in the case of an adiabatic expansion. However, if the expansion is not quasistatic, then turbulence and friction resulting from shock waves increase the thermal energy of molecules in the system, leading to a warming up of the system. Thus, the heat TdS were greater than zero, suggesting an increase in entropy. As spontaneous changes toward equilibrium increase the entropy, the energy due to the change TdS would “remain in the system”. This dissipation would manifest as a loss in the useful work. As a general conclusion, we can state that processes deviating from quasistatic changes always result in a *loss of the work* gained, and they *increase the entropy* of the system. In the above example, the heat exchanged with the surroundings was zero, but the change TdS was greater than zero. In case of a nonzero heat exchange with the surroundings, this would have meant that the change TdS was greater than the heat exchanged. Therefore, it can be formulated the following way:

$$TdS \geq \delta Q \quad \text{or} \quad dS \geq \frac{\delta Q}{T}. \quad (5.1)$$

The symbol δ (lower case Greek delta) is used to express that, though δQ is an infinitesimal quantity, it cannot be determined by any change in state variables, as it is a change during a nonquasistatic process. (Infinitesimal quasistatic work or heat is sometimes denoted by the symbol \bar{d} instead of a simple d , but we will not use this notation in the book. We know anyway from heat and work that they are not state functions.) Equality in (5.1) is only valid for quasistatic changes; in all other cases, inequality holds.

Having made a change in the state of the system from state A to state B, we can reverse the change depending on the accompanying change of entropy. If the entropy increased while passing from A to B, the process was spontaneous, but the reverse process can only be realized by the investment of energy. Namely, by changing internal constraints in an isolated composite system, the entropy will become maximal over the manifold of all unconstrained systems; thus, it can only increase during spontaneous changes. Would entropy have decreased while passing from state A to B (which would have been possible only by investment of energy), the reverse process could occur spontaneously. There are limiting cases when the value of entropy is the same in states A and B and also in every state in between during a quasistatic process. In this case, the forward process from A to B and the reverse process from B to A is possible to realize without investing energy. Due to this property, this latter process is referred to as a *reversible process*.² It should be noted that a nonquasistatic process is obviously not reversible (i.e., it is *irreversible*), as it implies an increase in entropy – as seen from (5.1).

²The word *reversible* is a derivative of the Latin noun *reversio* meaning return to a former state. Thus, reversible means “able to return”.

Let us summarize the above discussion in more formal terms. In the relations below, ΔS means a finite change, while dS means an infinitesimal change of entropy.

$\Delta S > 0$: natural (irreversible) process,

$\Delta S = 0$: reversible process,

$\Delta S < 0$: unnatural (not spontaneous) process,

$dS > \frac{\delta Q}{T}$: non-quasistatic (irreversible) process,

$dS = \frac{\delta Q}{T}$: quasistatic (reversible) process,

$dS < \frac{\delta Q}{T}$: impossible process.

It is important to note that thermodynamics strictly speaking describes only quasistatic processes. In case of real processes, thermodynamic calculations can only be used as an approximation as they cannot take into account any losses. This limitation also applies if we describe the operation of heat engines, refrigerators, and other thermodynamic devices using thermodynamic formalism.

5.2 Heat Engines: The Carnot Cycle and the Carnot Engine

Heat engines perform the conversion of thermal energy (heat) to mechanical work. Their schematic operational diagram is illustrated in Fig. 5.1. The conceptually most simple and most efficient heat engine is the *Carnot engine*, which operates on the *reversible Carnot cycle*. (The working fluid of a continuously operating engine should return over and over again into the same states; this is called a cyclic process or more simply a cycle.) The name is given after the author of the first theoretical treatment on devices converting heat into work.³ We know from the previous section that a quasistatic process is needed to avoid losses. It was Carnot who first suggested building engines in which change of temperature can only occur in processes delivering work in such a way that it is without any losses. The particular cycle realized in a Carnot engine is illustrated in Fig. 5.2.

It can be seen from the T - S diagram that both heat absorption and heat rejection occur at constant temperature. The expansion and cooling from the higher temperature T_h to the lower temperature T_c and the reverse direction heating occur

³Nicolas Léonard Sadi Carnot (1796–1832), a French engineer and military officer, published his 118-page book “*Réflexions sur la puissance motrice du feu et sur les machines propres à développer cette puissance*” 1824 in Paris. The long title means: reflections on the motive power of fire (i.e., heat) and on machines fitted to develop that power.

Fig. 5.1 Schematic diagram of a heat engine. During the operation of the engine, part of the energy Q_h absorbed from the hot heat reservoir (heat source) is used to drive a rotating axle (this is the useful work, W). Another part (Q_c) is rejected to the cold heat reservoir (heat sink) and delivered to the surroundings

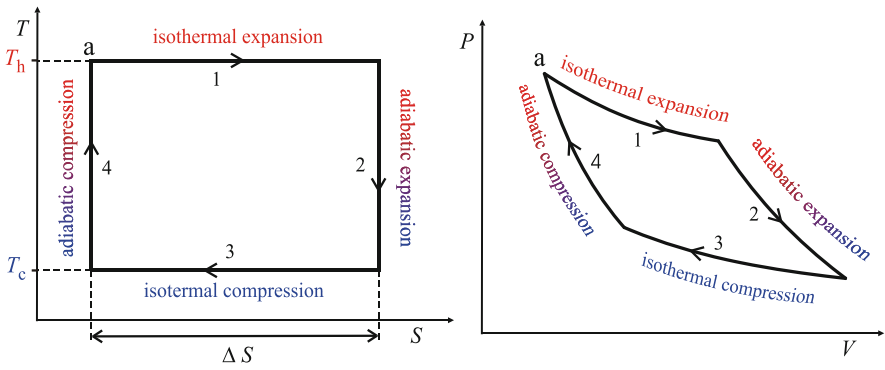
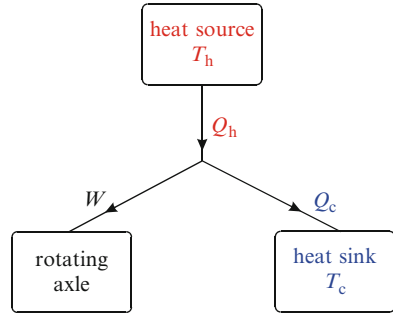

Fig. 5.2 The T - S and P - V diagram for the working fluid in a Carnot heat engine cycle. The four steps of the cycle are denoted by subsequent numbers starting from state a. A Carnot refrigerator or heat pump operates on the same cycle but in the reverse direction; its steps follow each other as $4 - 3 - 2 - 1$

adiabatically, enabling to convert the complete change in internal energy as volume work.

The *thermodynamic efficiency* of a heat engine is defined by the ratio:

$$\eta = \frac{\text{work gained}}{\text{energy consumed as heat}} \tag{5.2}$$

It is easy to calculate heat based on the T - S diagram, while the P - V diagram is practical for calculating work. In the P - V diagram of the Carnot cycle, we can see that work is done in all four steps of the cycle. During expansions, it is the working fluid that delivers work to the surroundings. Steps 1 and 3 occur at constant temperature and result in an exchange of heat between the working fluid and the surroundings. As temperature is constant, the exchanged heat (integral of TdS) can easily be calculated resulting in $T\Delta S$. Steps 2 and 4 are adiabatic changes avoiding heat exchange with the surroundings so that entropy would not change. After a complete cycle, the working fluid returns to the initial state (denoted by a) which requires that the entropy is the same at the end of the cycle as it was in the initial

state; thus, its increase in step 1 is the same as its decrease in step 3. (See also the previous figure.) In the complete cycle, the change of the internal energy should also be zero. Let us make use of these two relations to calculate the efficiency of the engine.

The internal energy changes due to the heat exchange in steps 1 and 3, and to the work done in each of the four steps. Let us denote the work done by the working fluid in steps 1 and 2 by W_{out} , and the work done by the surroundings in steps 2 and 4 by W_{in} . The difference $|W_{\text{out}}| - |W_{\text{in}}|$ is exactly the work gained in the numerator on the right-hand side of (5.2). In a similar manner, Q_{in} be the absorbed heat in step 1 and Q_{out} be the rejected heat in step 3. As mentioned above, the sum of all the work and heat during the complete cycle – the change in internal energy – is zero:

$$\Delta_1^4 U = |W_{\text{in}}| - |W_{\text{out}}| + |Q_{\text{in}}| - |Q_{\text{out}}| = 0. \quad (5.3)$$

Let us express the work gained $|W_{\text{out}}| - |W_{\text{in}}|$ from the above equation:

$$|W_{\text{out}}| - |W_{\text{in}}| = |Q_{\text{out}}| - |Q_{\text{in}}|. \quad (5.4)$$

By substituting this into (5.2), we get the efficiency of the Carnot engine:

$$\eta = \frac{\text{work gained}}{\text{energy consumed as heat}} = \frac{|W_{\text{out}}| - |W_{\text{in}}|}{|Q_{\text{in}}|} = \frac{|Q_{\text{in}}| - |Q_{\text{out}}|}{|Q_{\text{in}}|}. \quad (5.5)$$

As stated before, the heat exchange Q_{in} and Q_{out} can easily be calculated as $T_{\text{h}}\Delta S$ and $T_{\text{c}}\Delta S$. By substituting, we get:

$$\eta = \frac{T_{\text{h}}\Delta S - T_{\text{c}}\Delta S}{T_{\text{h}}\Delta S} = \frac{T_{\text{h}} - T_{\text{c}}}{T_{\text{h}}}. \quad (5.6)$$

By summing up the results, we can give the efficiency of the Carnot engine as

$$\eta = 1 - \frac{T_{\text{c}}}{T_{\text{h}}}. \quad (5.7)$$

We can see from the above result that the efficiency increases with decreasing heat sink temperature T_{c} . Unit efficiency can only be achieved if the temperature of the heat sink becomes $T_{\text{c}} = 0$ K. If the temperature of the heat sink is greater than 0 K – which is the case in practical heat engines – the efficiency is always smaller than 1. Thus, thermal energy cannot be completely converted into work. As we shall see later, to achieve the temperature 0 K, infinite energy was needed. Thus, we can state that, in general, the efficiency of heat engines is always inferior to one.

Heat engines used in power plants at the beginning of the twenty-first century operate with heat sources around 500°C and heat sinks around 80°C , equivalent to about 773 K and 353 K. The maximum efficiency calculated is 54.3%; thus,

existing power plants have somewhat smaller efficiency. Recently, the construction of smaller power plants that are built at riversides, using river water of about 20°C as a heat sink, is spreading. Their efficiency can be as high as 60%. The rejected heat (“waste heat”) can be used to domestic or industrial heating. Plants operating this way are called *cogeneration* or *combined heat and power* (CHP) plants. This is one of the most common forms of energy recycling.

5.3 Refrigerators and Heat Pumps: The Carnot Refrigerating and Heat-Pump Cycle

Refrigerators extract thermal energy (heat) from a cold room by consuming energy (mechanical work) and reject heat to a higher temperature room. (There are refrigerators consuming directly heat or electric energy to cool a cold room, but they are not discussed here.) Heat pumps operate the same way, but the goal using them is not to cool the cold room but to heat the hot room. The schematic operational diagrams of both devices are illustrated in Fig. 5.3.

On comparing Figs. 5.1 and 5.3, it can be seen that the operating cycle of a refrigerator or heat pump is basically the same as that of a heat engine, but they run in the opposite direction. The efficiency of these devices is thus calculated based on the same principles and quantities as for a heat engine.

The *coefficient of performance* (COP) of a refrigerator is the ratio of the heat withdrawn to the consumed work needed to withdraw this heat:

$$\varepsilon = \frac{\text{heat withdrawn from the cold room}}{\text{work consumed}}. \quad (5.8)$$

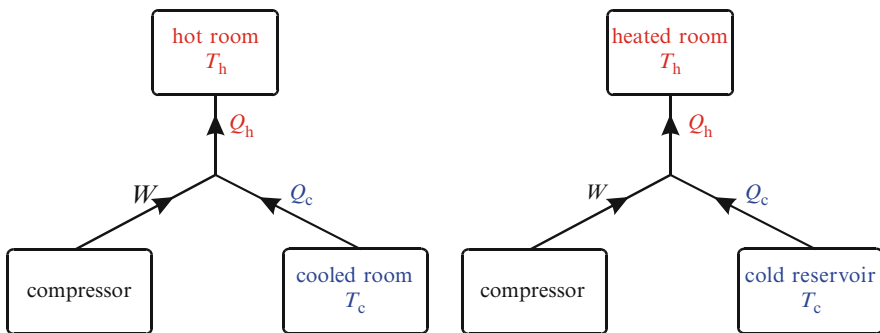

Fig. 5.3 Schematic diagram of a refrigerator (*left*) and a heat pump (*right*). The refrigerator consumes work W to withdraw heat Q_c from the refrigerated room at temperature T_c and to reject heat to the hot room at ambient temperature T_h . The heat pump consumes work W to withdraw heat Q_c from the cold reservoir at temperature T_c and to reject heat to the heated room at ambient temperature T_h .

For a Carnot refrigerator, we can readily enter Q_c in the numerator, $|W_{in}| - |W_{out}|$ in the denominator. From the energy conservation principle, this latter can be replaced by $|Q_{out}| - |Q_{in}|$, or, using the notation of Fig. 5.3, by $|Q_h| - |Q_c|$:

$$\varepsilon = \frac{|Q_c|}{|Q_h| - |Q_c|} = \frac{T_c \Delta S}{T_h \Delta S - T_c \Delta S} = \frac{T_c}{T_h - T_c}. \quad (5.9)$$

It can be seen from the resulting expression in terms of temperatures that the coefficient of performance decreases with decreasing temperature of the cooled room and with increasing temperature of the hot room. Unlike the efficiency η of a heat engine, the coefficient of performance ε of a refrigerator can be larger than 1. Domestic refrigerators usually reject heat to ambient air at temperatures somewhat higher than 20°C . The normal refrigerated room of temperature about 5°C can be cooled with an ideal coefficient of performance close to 14, while the freezer of temperature about -20°C only with that of less than 6. The waste heat of industrial refrigerators is also recycled; shopping centers are typically heated by the heat withdrawn from cooled storage rooms.

The *coefficient of performance of a heat pump* can be formulated in accordance with the task of the device: the ratio of the heat delivered to the heated room and the consumed work:

$$\varepsilon' = \frac{\text{heat delivered to the heated room}}{\text{work consumed}}. \quad (5.10)$$

Thus, we can enter Q_h in the numerator, and again, $|W_{in}| - |W_{out}|$ in the denominator. According to the energy conservation principle, this latter can be replaced by $|Q_{out}| - |Q_{in}|$, or equivalently $|Q_h| - |Q_c|$:

$$\varepsilon' = \frac{|Q_h|}{|Q_h| - |Q_c|} = \frac{T_h \Delta S}{T_h \Delta S - T_c \Delta S} = \frac{T_h}{T_h - T_c}. \quad (5.11)$$

We can see that the coefficient of performance of the heat pumps also diminishes with increasing difference between the temperatures of the hot and cold rooms.

It is interesting to compare the coefficient of performance of a refrigerator and a heat pump which operate between heat reservoirs of the same temperatures:

$$\varepsilon' - \varepsilon = \frac{T_h}{T_h - T_c} - \frac{T_c}{T_m - T_c} = 1. \quad (5.12)$$

Accordingly, the coefficient of performance of basically the same device is always greater by 1 if it is working as a heat pump.

The coefficient of performance of an ideal Carnot heat pump is 10.9 if an inner room of 22°C is heated from an outer temperature reservoir of -5°C . Though actual devices do not have this large a coefficient due to losses, it is still worth of

using a heat pump even if the actual coefficient of performance is only around 2. This means that twice the amount of heat can be gained from the work consumed in the heat pump than with direct electric heating using resistors. Where air conditioning is common practice, heating in winter can be done by slight modifications in the refrigerator of the air conditioner. The most frequent use of heat pumps for domestic heating is therefore seen in the Southern parts of the USA.

5.4 Heat Engines and Refrigerators Used in Practice

Though Carnot engines have the highest possible efficiency, their practical construction would be rather complicated. In the isothermal expansion step, the working fluid should absorb heat from the hot reservoir at the same temperature as that of the reservoir. This is of course impossible as if the temperatures are identical, there is equilibrium and no heat transfer. In principle, if the temperature of the working fluid is just slightly smaller than that of the reservoir, heat transfer could occur. This can be achieved if the working fluid is a liquid in equilibrium with its vapor at constant pressure. In this case, heat transfer can occur at constant temperature vaporizing the liquid, resulting in an expansion. Similarly, in contact with the cold reservoir, the fluid can condense (vapor transformed into liquid), thus rejecting heat to the reservoir. However, in the adiabatic expansion step of the Carnot cycle there would be liquid droplets besides the vapor, which would mechanically destroy the piston of a cylinder or the blades of a turbine. The compression of a liquid–vapor mixture would also raise serious mechanical problems. To compress a vapor, large compressors were needed which would lead to important energy losses, and the parts of the compressor would also be destroyed by liquid droplets. To avoid these problems, practical devices – heat engines, refrigerators, and heat pumps – operate on cycles different from the Carnot cycle. We only deal here with the *Rankine cycle* widely used in power plants, compressor refrigerators and heat pumps. It should be mentioned, however, that besides the closed Rankine vapor power cycle, there are different operational principles used, e.g., in internal combustion engines. Most important of them are the Otto cycle in petrol fuel engines and the Diesel cycle for diesel fuel engines.

5.4.1 Heat Engines Based on the Rankine Cycle

The Scottish engineer and physicist Rankine⁴ constructed a heat engine that is pretty close to the conditions formulated by Carnot. In his engine, the compression

⁴William John Macquorn Rankine (1820–1872), a Scottish engineer and physicist, played an important role during the early development of thermodynamics both in theory and construction of devices of practical use. He elaborated the modern theory of steam engines in 1850s and 1860s.

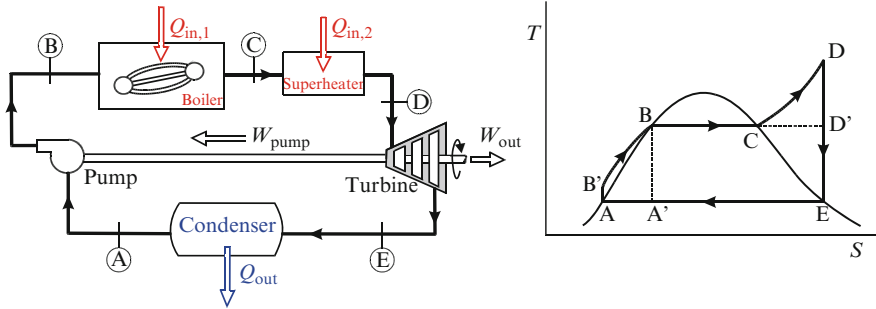

Fig. 5.4 Schematic diagram of a heat engine working on a Rankine vapor power cycle, and the T - S diagram of the cycle. Part of the heat absorbed in the boiler and the superheater by the working fluid is transformed into work in the turbine by expansion, making its axle turn. The exhaust steam becomes liquid water in the condenser, which is pumped into the boiler again. Letters in the schematic diagram indicate states in the T - S diagram. The flow direction of the working fluid is indicated by arrows. Large power plants are operating on this cycle with some modifications increasing efficiency

step (Fig. 5.2, step 4) is done with the smallest possible volume change, as the compressor only operates on the liquid, while the work production (adiabatic expansion) is done with the greatest possible volume change, using mostly vapor as expanding medium, with only an ignorable quantity of liquid. This cycle can be realized with minimal losses, while its efficiency is not much inferior to that of the Carnot engine. A schematic diagram of the device operating on the basis of the Rankine cycle along with a T - S diagram of the cycle is shown in Fig. 5.4.

The working fluid is pumped from state A into the boiler of higher pressure and temperature, where it evaporates between points B and C at constant temperature forming saturated vapor. During this process, its entropy (i.e., its heat content) increases. (The bell-shaped curve in the T - S diagram is the liquid-vapor equilibrium curve. To its left side, there is liquid; to its right side, there is vapor. Below the curve, there exist no phases; if the state of the system coincides with such a point, the system exists at the intersection points of a horizontal line with the curve as the corresponding liquid and vapor. The ratio of vapor to liquid depends on the distance of the point from the two intersections along the horizontal line. A detailed discussion of liquid-vapor equilibrium can be found in Sect. 7.2.) Following evaporation, the steam is superheated at constant pressure between states C and D. The next step is the expansion of the high-pressure hot steam resulting in useful work on the turning axle of the turbine. Finally, the exhaust steam completely condenses in the cooled condenser at constant temperature. (Cooling is necessary to absorb the heat of condensation.) Following condensation, the working fluid is pumped again into the boiler, thus entering a new cycle.

To calculate the efficiency of the cycle, work and heat associated with isotherms B-C and E-A, the isobar E-A, and the adiabat D-E are easy to calculate, but the change in energy of a liquid-vapor equilibrium system between A and B (along the bell-shaped curve) is not easy to describe. However, it can be replaced by

calculating energy changes during an adiabatic compression $A-B'$ and a subsequent isobaric heating $B'-B$.

In Fig. 5.4, an imaginary Carnot cycle $A' - B - D' - E$ between the temperatures of the Rankine engine boiler and condenser is also shown, as a rectangle containing dashed lines. To realize this cycle, we can see that a liquid-gas mixture should have been compressed from state A' to B , which can only be done with complicated devices and important losses. Between states C and D' , an isothermal expansion of the steam should have been done which is also complicated to realize. (If there was not a superheating of the steam, it would have been introduced into the turbine in state C as saturated vapor and would liquefy during expansion into small droplets damaging turbine blades.) These technical complications and energy losses can all be avoided by the Rankine cycle at the price of a lower efficiency, even for an ideal operation without losses, compared to the Carnot cycle operating between the same two heat reservoirs. The theoretical efficiency of a Carnot engine operating between a 600°C and a 20°C heat reservoir is 66.4 %. A Rankine engine working with 600°C superheated water steam and a 20°C condenser has only 44.1% theoretical efficiency. However, energy losses are so small for this engine that there exists a power plant working at 39% effective efficiency.

5.4.2 Refrigerators and Heat Pumps Based on the Rankine Cycle

Domestic compressor refrigerators usually operate on a Rankine cycle. The actual device – whose schematic diagram is shown in Fig. 5.5 – operates almost in an identical cycle to the Rankine engine, except for its reverse direction. The most striking difference is the throttling valve between states E and D in place of the

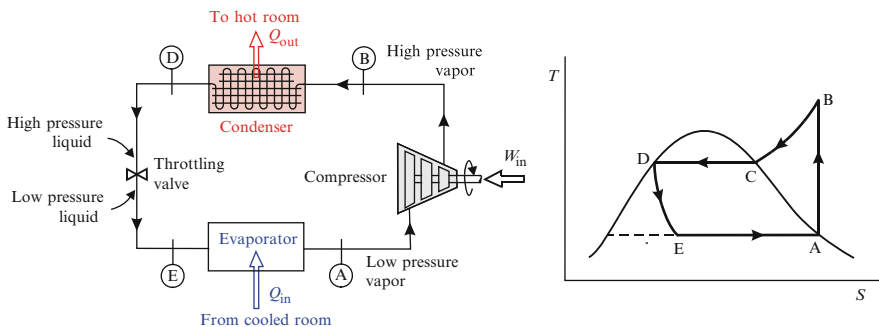

Fig. 5.5 Schematic diagram of a refrigerator working on a Rankine vapor compression cycle, and the $T-S$ diagram of the cycle. The heat absorbed from the cooled room is used to produce vapor from liquid in the evaporator. The compressed vapor rejects heat to the hot room during condensation. Letters in the schematic diagram indicate states in the $T-S$ diagram. The flow direction of the working fluid is indicated by arrows

turbine. (The throttling valve may be a small orifice on a plate, a porous ceramic filter, or a capillary within the tube. The gas expands across the throttle and its pressure drops.) The reason for this change is clear from the T - S diagram; the liquid expanding from state D partly evaporates. This would lead to the technical problems mentioned above in the operation of the turbine, and the liquid part of the mixture would produce much less work while expanding than the vapor. In this case, it is not worth recycling; it will take the form of losses. Another difference is that, having reversed the direction of the engine cycle, it is not the liquid to be pumped but the vapor to be compressed.

The refrigeration cycle begins with compressing the vapor by an adiabatic compressor from the low-pressure state A into the high-pressure state B, the entrance point of the condenser coil. The vapor is condensed inside the coil and the heat released is dissipated to ambient air. The high-pressure liquid formed (state D) expands through the throttling valve and forms a low-pressure liquid-vapor mixture (state E) to enter the evaporator. There, its liquid content evaporates at constant temperature, withdrawing the necessary heat of evaporation from the cooled room. After evaporation, the fluid is once again in the vapor state A; thus, the cycle is closed and it starts over by compression.

The throttling valve between states E and D is usually a thin capillary. The change of state across the valve is an *isenthalpic* expansion. During this process, the entropy increases and the liquid partially evaporates. This part of the cycle is essentially different from the Rankine engine cycle.

The coefficient of performance of a Rankine vapor compression cycle is somewhat lower than that of a Carnot refrigeration cycle. In domestic refrigerators, there are also important losses. As a result, a common domestic refrigerator usually has a coefficient of performance of about 2.5, while a deep-freezer unit is only slightly higher than 1. The coefficient of performance of heat pumps operating between moderately large temperature differences is around 4.

5.4.3 *Isenthalpic Processes: The Joule–Thompson Effect*

As mentioned in the previous section, expansion through a throttle has a great practical importance. Apart from refrigerators, this procedure is also used in devices to liquefy gases. The first realization of a throttling expansion (see Fig. 5.6) was done by Joule⁵ and Thomson; thus, it is also called a *Joule–Thomson process* (or Joule–Kelvin process). Their original throttle was a silk tissue, later changed for sea sponge. Actual devices are small orifices on a plate, thin capillaries or glass membrane filters of small pore diameter.

⁵James Prescott Joule (1818–1899) was a Scottish brewer and hobby scientist. His scientific activity was most fruitful in experimental studies of energy transformations. The SI unit of energy is named after him.

Fig. 5.6 Schematic diagram of a device for a

Joule–Thomson process. The gas at high-pressure P_{in} seeps across the throttle while expanding to the low-pressure P_{out} . The flow of the gas across the throttling is low enough so that equilibrium is maintained at both sides

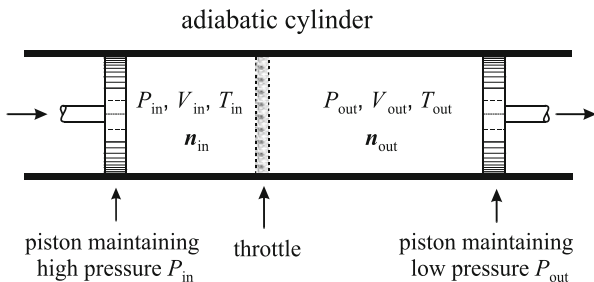

Let us describe the change when n_{in} mol of the gas is compressed across the throttle at constant pressure P_{in} on the high-pressure side and P_{out} on the low-pressure side; i.e., $n_{\text{in}} = n_{\text{out}}$. Both pistons and the cylinder are adiabatic; thus, the energy of the gas can only change by the work $P_{\text{in}}V_{\text{in}}$ done by the left, and $P_{\text{out}}V_{\text{out}}$ done by the right piston:

$$U_{\text{out}} = U_{\text{in}} + P_{\text{in}}V_{\text{in}} - P_{\text{out}}V_{\text{out}}. \quad (5.13)$$

By rearranging, we get

$$U_{\text{out}} + P_{\text{out}}V_{\text{out}} = U_{\text{in}} + P_{\text{in}}V_{\text{in}}, \quad (5.14)$$

which is equivalent to the equality $H_{\text{out}} = H_{\text{in}}$, showing that the enthalpy did not change during the process. This is the reason to call it an *isenthalpic process*.

The change in temperature during the process can be given by integrating

$$dT = \left(\frac{\partial T}{\partial P} \right)_{H,n} dP, \quad (5.15)$$

and the result – apart from the difference in pressure – depends on the *Joule–Thomson coefficient* $\left(\frac{\partial T}{\partial P} \right)_{H,n}$. This coefficient can be calculated from the measurable quantities introduced in Sect. 4.4.2. To perform the calculations, suppose that the composition does not change, and let us relate all quantities to $n = 1$ mol; thus, the variable n is no more necessary to write. Using the cyclic rule (F1.23), the Joule–Thomson coefficient can be written as follows:

$$\left(\frac{\partial T}{\partial P} \right)_H = - \frac{\left(\frac{\partial H}{\partial P} \right)_T}{\left(\frac{\partial H}{\partial T} \right)_P} \quad (5.16)$$

We have identified the measurable quantities as the second derivatives of the function $G(T, P, n)$. Thus, based on the definition of enthalpy

$$H = G + TS, \quad (5.17)$$

we can write

$$\left(\frac{\partial H}{\partial P} \right)_T = \left(\frac{\partial G}{\partial P} \right)_T + T \left(\frac{\partial S}{\partial P} \right)_T \quad (5.18)$$

We can substitute from (4.38) αv in place of $(dS/dP)_T$. From (4.51), we know that $(dG/dP)_T$ is the volume; thus, we can replace it by the molar volume v . Taking this into account, the numerator in (5.16) becomes

$$\left(\frac{\partial H}{\partial P}\right)_T = v - \alpha T v. \quad (5.19)$$

The denominator (as it is also related to 1 mol) is the molar heat capacity c_P . Using these results, the Joule–Thomson coefficient can be given as follows:

$$\left(\frac{\partial T}{\partial P}\right)_H = -\frac{v}{c_P}(1 - \alpha T). \quad (5.20)$$

The pressure decreases when the gas passes across the throttling (i.e., $dP < 0$); thus, the process results in a decrease in temperature if the Joule–Thomson coefficient is positive ($\alpha T > 1$). Conversely, in case of a negative coefficient ($\alpha T < 1$), it results in an increase in temperature. The switching between the two regimes depends on the value of the coefficient of thermal expansion α . The temperature at which the Joule–Thomson coefficient changes sign (and it is zero) is called the *inversion temperature*. It is clear from the above results that it can be calculated from the equation

$$\alpha T_{\text{inversion}} = 1. \quad (5.21)$$

The coefficient of thermal expansion for an ideal gas is easy to calculate:

$$\alpha = \frac{1}{V} \left(\frac{\partial V}{\partial T}\right)_{P,n} = \frac{nR}{PV} = \frac{1}{T}. \quad (5.22)$$

We can see that the product αT is always 1 for an ideal gas; thus, its Joule–Thomson coefficient is zero and there is no change in temperature when it passes across a throttling. In case of real gases, there exists an inversion temperature depending on pressure, and there exists a pressure and temperature region within which they always get cooled when passing through a throttling. Hydrogen gas, for example, cools below 193 K (-100.16°C) at atmospheric pressure. All other gases – except for helium – have a higher inversion temperature.

In a liquefying device, gases are first cooled below their inversion temperature and then expanded across a throttle. During this expansion, a part of the gas becomes liquid. The rest is pressed again across the throttling, resulting in further liquefaction. A continuous liquefaction can be maintained in this way.

Problems

1. Electric energy delivered from a power company is used to provide heating to our apartment to a temperature of 25°C in an environment of -2°C . To what factor can we improve our cost–benefit ratio if we use electric energy to drive an ideal Carnot heat pump rather than directly heating with a resistor?

Solution: As a heating resistor transforms electric energy directly into heat, the “efficiency” of heating is exactly 1. A Carnot heat pump has a coefficient of performance

$$\varepsilon' = \frac{T_h}{T_h - T_c},$$

according to (5.11). Upon substitution of $T_h = 298.16$ K and $T_c = 271.16$ K, we get $\varepsilon' = 11.04$. Thus, we have to pay 11 times less for heating. (In reality, the efficiency of existing domestic heat pumps is much less than this, due to different construction with respect to a Carnot device and eventual losses, but it is still close to a coefficient of performance of 5 at the given conditions.)

2. The so-called *air-standard Otto cycle* is a rough model approximation of the operation of actual four-stroke petrol fuel engines in cars. In this cycle, the working fluid is considered to be air only (for the sake of simplicity supposed to be a monatomic ideal gas), the combustion as a simple heat intake, and exhaustion as a simple heat rejection. Thus, the cycle contains the following steps:

(a) an adiabatic compression; (b) a constant volume heating; (c) an adiabatic expansion; and (d) a constant volume cooling to the initial state.

As the piston moves from the head-end dead center to the crank-end dead center, the working fluid has twice the minimum volume and twice the maximum volume during the cycle; i.e., $V_A = V_D$ and $V_B = V_C$.

Sketch the operation of the cycle in a T - S and a P - V diagram and show that the efficiency of the engine can be given as

$$\eta = 1 - \left(\frac{V_A}{V_B} \right)^{-2/3},$$

if V_A is the volume of the working medium before, and V_B is that after the adiabatic compression.

Solution: According to the above description, the operation of the four-stroke Otto cycle can be drawn in the two diagrams as seen below:

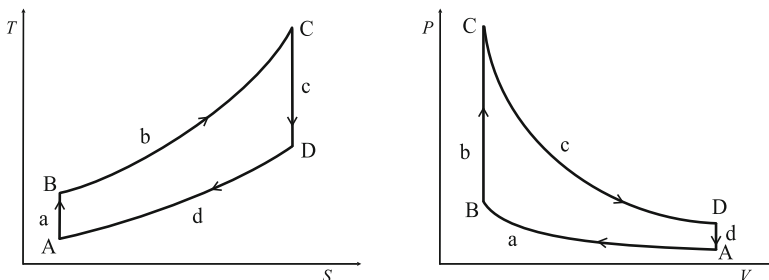

Fig. 5.7 The T - S and P - V diagram for the working fluid in the air-standard Otto cycle

According to (5.5), the efficiency of a heat engine can be expressed in the following way:

$$\eta = \frac{|Q_{\text{in}}| - |Q_{\text{out}}|}{|Q_{\text{in}}|} = 1 - \frac{|Q_{\text{out}}|}{|Q_{\text{in}}|}$$

Heat is only absorbed in process b and rejected in process d, and both processes are at constant volume; thus we can write $Q_{\text{in}} = C_V \Delta_B^C T$ and $Q_{\text{out}} = -C_V \Delta_D^A T$, and

$$\eta = 1 - \frac{|Q_{\text{out}}|}{|Q_{\text{in}}|} = 1 - \frac{C_V(T_D - T_A)}{C_V(T_C - T_B)} = 1 - \frac{T_D - T_A}{T_C - T_B}.$$

To find the relation between temperature and volume during the isentropic processes a and c, when there is no heat exchange but only work exchanged with the surroundings, we can proceed similarly to the treatment of Sect. 4.4.2. Let us start from (2.26) written for a closed system (as we only consider air as a monatomic gas without chemical changes):

$$dS = \frac{1}{T} dU + \frac{P}{T} dV.$$

For the monatomic ideal gas, we can write

$$(dU)_V = \frac{3}{2} nR dT \quad \text{and} \quad \frac{P}{T} = \frac{nR}{V}.$$

Thus, we get

$$dS = \frac{3nR}{2T} dT + \frac{nR}{V} dV.$$

As the first term is independent of V and the second one is independent of T , integration can be performed in the following way:

$$\Delta S = \frac{3}{2} nR \int_{T_A}^{T_B} \frac{1}{T} dT + nR \int_{V_A}^{V_B} \frac{1}{V} dV.$$

As a result, we get:

$$\Delta S = \frac{3}{2} nR \ln \frac{T_B}{T_A} + nR \ln \frac{V_B}{V_A}.$$

For the isentropic change, i.e., $\Delta S = 0$, this leads to

$$-\frac{3}{2} \ln \frac{T_B}{T_A} = \ln \frac{V_B}{V_A}.$$

Exponentiation of the two sides provides the searched-for relation of T and V :

$$\left(\frac{T_B}{T_A}\right)^{-3/2} = \frac{V_B}{V_A} \quad \text{or} \quad \frac{T_B}{T_A} = \left(\frac{V_B}{V_A}\right)^{-2/3}.$$

As $V_A = V_D$ and $V_B = V_C$, we can write the equalities:

$$\frac{T_A}{T_B} = \left(\frac{V_A}{V_B}\right)^{-2/3} = \left(\frac{V_D}{V_C}\right)^{-2/3} = \frac{T_D}{T_C}.$$

From the equality $T_A/T_B = T_D/T_C$, it follows that $T_D/T_A = T_C/T_B$. We may rewrite the equation from the efficiency to contain similar ratios:

$$\eta = 1 - \frac{T_D - T_A}{T_C - T_B} = 1 - \frac{T_A(T_D/T_A - 1)}{T_B(T_C/T_B - 1)}.$$

As we can see, the fraction reduces to T_A/T_B , which we can express from the above results as $(V_A/V_B)^{-2/3}$. Thus, we obtain the formula we had to prove:

$$\eta = 1 - \left(\frac{V_A}{V_B}\right)^{-2/3}.$$

Note that the efficiency of the Otto cycle improves with increasing compression ratio V_A/V_B . This is the reason to increase this ratio in modern engines up to 10, above which it is not worth to further improve the antiknocking properties of the fuel. Also note that for air, the efficiency is quite lower than the one calculated for the monatomic gas.

Further Reading

- Atkins P, de Paula J (2009) *Physical chemistry*, 9th edn. Oxford University Press, Oxford
- Callen HB (1985) *Thermodynamics and an introduction to thermostatistics*, 2nd edn. Wiley, New York
- Carnot S (1824) *Réflexions sur la puissance motrice du feu et sur les machines propres à développer cette puissance*. Bachelier, Paris
- English translation: Carnot S, Thurston RH (editor and translator) (1890) *Reflections on the motive power of heat and on machines fitted to develop that power*. Wiley, New York
- Denbigh KG (1981) *The principles of chemical equilibrium*, 4th edn. Cambridge University Press, Cambridge
- Guggenheim EA (1985) *Thermodynamics: an advanced treatment for chemists and physicists*, 7th edn. North Holland, Amsterdam
- Silbey LJ, Alberty RA, Moungi GB (2004) *Physical chemistry*, 4th edn. Wiley, New York
- Sonntag RE, Borgnakke C (2001) *Introduction to engineering thermodynamics*. Wiley, New York

Chapter 6

Thermodynamics of Mixtures (Multicomponent Systems)

Chemistry typically deals with systems containing several components – called *mixtures* – whose composition can also change. For this reason, it is important to explore how thermodynamic properties depend on the composition. As we shall see, it is not a simple problem due to the great variety of components as well as the nature of their interactions in mixtures. For historical reasons, thermodynamic description of real mixtures is seemingly rather simple; a formal description based on the behavior of mixtures of ideal gases is adapted for them. The origin of this formalism is that early experiments on mixtures concentrated for finding simple relations of general validity, even if they were only approximately valid. This was an efficient method to formalize the theoretical basis, but this simple formalism has been conserved. The great advantage of this thermodynamic formalism is the simplicity and generality of relations concerning ideal gas mixtures. However, keeping this formalism for *real mixtures* necessitates to introduce (and understand) a complicated system of conventions. This feature makes chemical thermodynamics a rather special topic.

This chapter begins with describing the basic formalism on the example of a mixture of ideal gases, and then this description is extended for use in the case of real mixtures. As the most common and useful thermodynamic function in chemical applications is the chemical potential as a function of pressure and temperature, we shall concentrate on the dependence on composition of the chemical potential when the other variables are pressure and temperature.

6.1 Partial Molar Quantities

In earlier chapters, we have frequently used *molar quantities* to describe thermodynamic properties if the extent of the system was not important. We obtained these quantities by dividing the extensive quantities by the total amount of the system, which is the sum of the amounts of all the components. Let us consider an extensive thermodynamic property X as a function of the temperature T , the pressure P , and

the composition given as the amounts of the K components n_1, n_2, \dots, n_K . The molar quantity of X is calculated as

$$x = \frac{X}{\sum_{i=1}^K n_i}. \quad (6.1)$$

From this molar quantity x , we get back the extensive property when multiplying it by the total amount of substance $n = \sum_{i=1}^K n_i$:

$$X = nx \quad (6.2)$$

The function $X = X(T, P, n_1, n_2, \dots, n_K)$ is homogeneous first order in the amounts n_1, n_2, \dots, n_K . According to the Euler theorem for homogeneous first-order functions (see (2.31)):

$$X(T, P, n_1, n_2, \dots, n_K) = \sum_{i=1}^K \left(\frac{\partial X}{\partial n_i} \right)_{T, P, n_j \neq i} n_i. \quad (6.3)$$

Partial derivatives in the above sum are called *partial molar quantities*. We shall denote them by the symbol X_i :

$$X_i = \left(\frac{\partial X}{\partial n_i} \right)_{T, P, n_j \neq i}. \quad (6.4)$$

Using this notation, (6.3) can be written in the form:

$$X = \sum_{i=1}^K n_i X_i. \quad (6.5)$$

We may interpret this result telling that the extensive quantity X can be calculated as the sum of the contributions of each component, where the individual contribution is the partial molar quantity multiplied by the amount of the component. Note that partial molar quantities are not independent of the composition. Being derivatives of the function $X(T, P, n_1, n_2, \dots, n_K)$, they are functions of the same variables, i.e., of T, P , and the amounts n_1, n_2, \dots, n_K . However – unlike the original extensive function – $X_i(T, P, n_1, n_2, \dots, n_K)$ is homogeneous zero-order function in the amounts n_1, n_2, \dots, n_K ; thus, it is independent of the extent of the system, and the transformation of (2.12) holds:

$$X_i(T, P, \lambda n_1, \lambda n_2, \dots, \lambda n_K) = X_i(T, P, n_1, n_2, \dots, n_K) \quad (6.6)$$

By choosing the factor $\lambda = 1/n$, we get the transformed as a function of the variables n_i/n , i.e., of the mole fractions x_i :

$$X_i(T, P, x_1, x_2, \dots, x_K) = X_i(T, P, n_1, n_2, \dots, n_K) \quad (6.7)$$

It is important to note that the mole fractions x_i are not independent (cf. (2.10)); consequently, it is enough to specify $K - 1$ of them. (This is in accordance with the fact that the number of degrees of freedom in case of intensive characterization of the system is one less than in case of extensive characterization.)

Partial molar quantities have an important role in the thermodynamic description of mixtures. It is easy to show that relations between extensive variables also hold between the respective partial molar quantities.

6.1.1 Chemical Potential as a Partial Molar Quantity

Let us illustrate the properties of the general partial molar quantity X_i defined above on the example of the chemical potential of component i . It is obvious now that we can calculate it as the partial molar quantity of the Gibbs potential function $G(T, P, n_1, n_2, \dots, n_K)$ (cf. (4.22)):

$$\mu_i(T, P, x_1, x_2, \dots, x_K) = \left(\frac{\partial G}{\partial n_i} \right)_{T, P, n_j \neq i} \quad (6.8)$$

(Note that the symbol μ_i will be used instead of G_i for this quantity and the corresponding function; thus, it differs from the usual notation of partial molar quantities in form of a subscripted capital letter.)

By derivating both sides of the equation $G = H - TS$ with respect to n_i (considering that the other variables T, P , and the further amounts of components different from i are constant from the point of view of derivation), we get the equation:

$$\mu_i = H_i - TS_i. \quad (6.9)$$

The total differential of the function $\mu_i(T, P, x_1, x_2, \dots, x_K)$ can be written formally as

$$d\mu_i = \left(\frac{\partial \mu_i}{\partial T} \right)_{P, \mathbf{x}} dT + \left(\frac{\partial \mu_i}{\partial P} \right)_{T, \mathbf{x}} dP + \sum_{i=1}^K \left(\frac{\partial \mu_i}{\partial x_i} \right)_{T, P, x_j \neq i} dx_i, \quad (6.10)$$

where \mathbf{x} denotes the composition vector (x_1, x_2, \dots, x_K) . Based on (4.22):

$$dG = -SdT + VdP + \sum_{i=1}^K \mu_i dn_i,$$

we can identify the partial derivatives of the function $G(T, P, n_1, n_2, \dots, n_K)$ as follows:

$$\left(\frac{\partial G}{\partial T}\right)_{P,n} = -S \quad \left(\frac{\partial G}{\partial P}\right)_{T,n} = V \quad \left(\frac{\partial G}{\partial n_i}\right)_{T,P,n_{j \neq i}} = \mu_i.$$

Accordingly, the two first partial derivatives of μ_i in (6.10) can be obtained as second partial derivatives of the function G :

$$\left(\frac{\partial \mu_i}{\partial T}\right)_{P,n} = \frac{\partial}{\partial T} \left(\frac{\partial G}{\partial n_i}\right)_{T,P,n_{j \neq i}} = \frac{\partial}{\partial n_i} \left(\frac{\partial G}{\partial T}\right)_{P,n} = -\left(\frac{\partial S}{\partial n_i}\right)_{T,P,n_{j \neq i}} = -S_i, \quad (6.11)$$

$$\left(\frac{\partial \mu_i}{\partial P}\right)_{T,n} = \frac{\partial}{\partial P} \left(\frac{\partial G}{\partial n_i}\right)_{T,P,n_{j \neq i}} = \frac{\partial}{\partial n_i} \left(\frac{\partial G}{\partial P}\right)_{T,n} = \left(\frac{\partial V}{\partial n_i}\right)_{T,P,n_{j \neq i}} = V_i. \quad (6.12)$$

In the above derivations, we have made use of the rule that we get the same function irrespective of the order of derivation. Consequently, by analogy to (4.22), we can write the total differential of the function $\mu_i(T, P, x_1, x_2, \dots, x_K)$ in the following form:

$$d\mu_i = -S_i dT + V_i dP + \sum_{i=1}^K \left(\frac{\partial \mu_i}{\partial x_i}\right)_{T,P,x_{j \neq i}} dx_i. \quad (6.13)$$

This result illustrates well that relations between extensive variables also hold between the respective partial molar quantities.

6.1.2 Determination of Partial Molar Quantities from Experimental Data

Mixtures of two components – usually called as *binary*¹ mixtures – are common in chemical practice. They occur not only in case of two chemical components in a mixture, but in a broader sense, also if one of the multiple components is considered as “solute,” and all the remaining components as “solvent”. Accordingly, we usually do not speak about mixtures but solutions. In a binary mixture, one concentration is enough to specify the composition, as the concentration of the other component is not independent; it can be calculated from the first component’s concentration. We shall discuss the determination of partial molar quantities on the

¹The word comes from the Latin *binarius* meaning “two things together”. Its meaning in mathematics is the system of numbers consisting of two symbols, usually 0 and 1.

example of a binary mixture, which is, of course, applicable to a solute–multi-component solvent system as well.

As we shall extensively use the symbol x for the mole fraction, it is more appropriate to use V for the extensive variable instead of X to avoid confusion. Accordingly, we shall also call V as volume. Thus, we can state the aim of the following discussion: it is the determination of the partial molar volumes of the components from the measured molar volumes of a binary mixture at constant temperature and pressure. In case of two components, the molar volume of the mixture is

$$v = \frac{V}{n_1 + n_2}, \quad (6.14)$$

from which we obtain:

$$V = v(n_1 + n_2) \quad (6.15)$$

The partial molar volume of component 1 can be obtained from (6.4) as the partial derivative of the right-side product of (6.15). To simplify notation, we do not show the variables T and P as they are constant in the experiments:

$$V_1 = \left(\frac{\partial V}{\partial n_1} \right)_{n_2} = v + (n_1 + n_2) \left(\frac{\partial v}{\partial n_1} \right)_{n_2}. \quad (6.16)$$

To justify this result, we should take into account that the first term of the derivative of the product is $v \partial(n_1 + n_2)/\partial n_1$ and that $\partial n_1/\partial n_1 = 1$ and $\partial n_2/\partial n_1 = 0$. We would like to use the derivative of molar volume with respect to x_2 instead of n_1 , which we can write using the chain rule as follows:

$$\left(\frac{\partial v}{\partial n_1} \right)_{n_2} = \left(\frac{\partial x_2}{\partial n_1} \right)_{n_2} \frac{dv}{dx_2} \quad (6.17)$$

(The function $v(x_2)$ is only a univariate function, which is the reason for not writing a partial derivative in dv/dx_2 .) The partial derivative of the mole fraction x_2 with respect to n_1 is:

$$\left(\frac{\partial x_2}{\partial n_1} \right)_{n_2} = \frac{\partial}{\partial n_1} \left(\frac{n_2}{n_1 + n_2} \right) = \frac{(n_1 + n_2) \left(\frac{\partial n_2}{\partial n_1} \right) - n_2 \left(\frac{\partial (n_1 + n_2)}{\partial n_1} \right)}{(n_1 + n_2)^2} = - \frac{n_2}{(n_1 + n_2)^2}. \quad (6.18)$$

Let us substitute the partial derivative calculated above into (6.16):

$$V_1 = v - \frac{n_2}{(n_1 + n_2)} \frac{\partial v}{\partial x_2} = v - \frac{\partial v}{\partial x_2} x_2 \quad (6.19)$$

This can be used to calculate the partial molar volume V_1 . By rearranging this equation, we get an expression to graphically plot the result:

$$v = V_1 + \frac{\partial v}{\partial x_2} x_2 \quad (6.20)$$

This is the equation of a straight line whose intercept (the value at $x_2 = 0$) is the molar volume of component 1. The molar volume of the other component, V_2 , can be given from (6.5) as follows:

$$v = (1 - x_2)V_1 + x_2V_2. \quad (6.21)$$

As seen in Fig. 6.1, in a graphical representation the tangent line of the graph of the function at mole fraction x_2 can be used to determine the partial molar volumes. The intercept of the line at $x_2 = 0$ gives V_1 , while the intercept at $x_2 = 1$ gives V_2 .

We shall see later that the partial molar volume of a component at its zero concentration is a quantity of interest. This is obviously not the molar volume of the pure solvent, but the extrapolated value of the function $v(x_2)$ to $x_2 = 0$. This extrapolation is easy to perform if we fit a power series to the experimental data. The constant term of this series gives the extrapolated partial molar volume of component 1, the sum of the constant term and the coefficient of the first-order term gives that of component 2 (both at $x_2 = 0$).

The procedure discussed above can, of course, be used not only in case of volume, but any other extensive quantities (U , H , F , G , *etc.*) to determine the corresponding partial molar quantity.

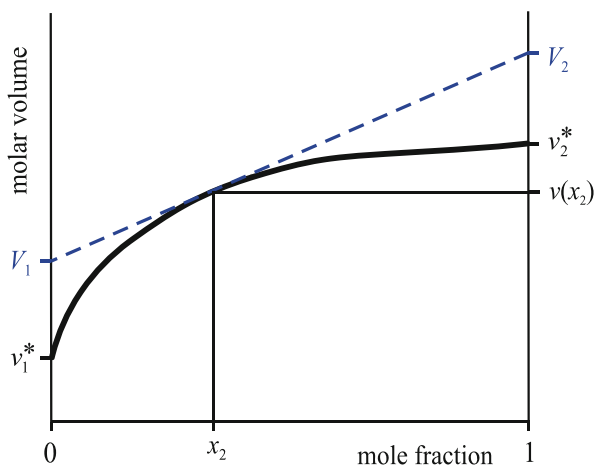

Fig. 6.1 Determining partial molar volume using the method of intercepts in a binary mixture. At the composition x_2 shown, the partial molar volume of component 1 is V_1 , while that of component 2 is V_2

6.2 Thermodynamics of Ideal Mixtures

As already mentioned at the beginning of this chapter, the formalism used to describe thermodynamic properties of mixtures is based on the description of mixtures of ideal gases; thus, we begin this section by discussing these mixtures. Their practical importance is negligible in chemistry, but their characterization enables to understand the thermodynamic formalism used to describe real mixtures of practical importance.

6.2.1 Ideal Gas Mixtures

Mechanical properties of an ideal gas can be calculated using the equation of state given in (2.39):

$$V = \frac{nRT}{P}. \quad (6.22)$$

In an ideal gas, there is no interaction between molecules (apart from elastic collisions); thus, a mixture of different ideal gas species also behaves as an ideal gas. This means that the behavior of the mixture components is independent of the presence and concentration of other components. If we write individual components explicitly in (6.22), it becomes:

$$V = \frac{RT \sum_{i=1}^K n_i}{P}. \quad (6.23)$$

It is easy to calculate partial molar volumes from this form:

$$\left(\frac{\partial V}{\partial n_i} \right)_{T, P, n_{j \neq i}} = V_i = \frac{RT}{P}. \quad (6.24)$$

This is exactly the same as the molar volume of the mixture. We can interpret this by saying that each component fills the whole volume accessible. A consequence of the equality of the molar volume for each component is that the total volume can be given as $V_i \sum_{i=1}^K n_i$. As the components behave independently, we can also associate with each of them the pressure which they would have if they were only alone in the whole volume, without the other components. From (6.22) and (6.24), this pressure is

$$p_i = \frac{n_i RT}{V}, \quad (6.25)$$

while the total pressure is

$$P = \frac{\sum_{i=1}^K n_i RT}{V}. \quad (6.26)$$

Comparing the two equations, we can deduce a simple expression:

$$p_i = \frac{n_i}{\sum_{i=1}^K n_i} P = x_i P. \quad (6.27)$$

Summing up we can say that the total pressure P of a mixture of ideal gases can be obtained as the weighted sum by the mole fractions x_i of the partial pressures p_i . The partial pressures p_i are also identical to the pressures which individual components would have if they were only alone in the whole volume V , without the other components. This relation is called *Dalton's Law*, named after its first identifier.²

It is important to note that the partial pressure is always defined as

$$p_i = x_i P, \quad (6.28)$$

but, for a real gas, it is usually not the same as the pressure of the pure component being alone in the total volume of the mixture. It is also worth noting that the partial pressure p_i is *not a partial molar quantity*, as it is not the partial derivative of a function determining an extensive quantity.

Based on the above results, we can determine the chemical potential of the components of an ideal gas mixture as a function of the concentration. To do so, let us start from (6.13) writing it for a closed system ($dx_i = 0, \forall i$) at constant temperature ($dT = 0$):

$$d\mu_i = V_i dP \quad (6.29)$$

In accordance with the above results, let us conceive the mixture by expanding each component from the total pressure P to its actual partial pressure p_i in the mixture. (The total pressure is P , in accordance with (6.28)). The chemical potential of the components can be obtained by integration of the above equation:

$$\mu_i(T, p_i) = \mu_i(T, P) + \int_P^{p_i} V_i dp. \quad (6.30)$$

²John Dalton (1766–1844) was an English chemist and physicist, one of the determining persons who established and made accepted the atomic theory in chemistry. His experimental studies on gases also contributed to the development of his atomic theory.

Substitute the volume of an ideal gas into the integrand:

$$\mu_i(T, p_i) = \mu_i(T, P) + \int_P^{p_i} \frac{RT}{p} dp = \mu_i(T, P) + RT \ln \frac{p_i}{P}. \quad (6.31)$$

According to (6.28), we can substitute x_i for p_i/P :

$$\mu_i(T, p_i) = \mu_i(T, P) + RT \ln x_i. \quad (6.32)$$

As p_i uniquely determines x_i , this equation can be rewritten in the form:

$$\mu_i(T, P, x_i) = \mu_i(T, P) + RT \ln x_i \quad (6.33)$$

Equation (6.33) determines the chemical potential of the species i in an ideal gas mixture at a given temperature T and pressure P as a function of the concentration. Note that the function $\mu_i(T, P, x_i)$ depends only on the concentration of the species i and does not depend on the concentration of any other species.

6.2.2 Properties of Ideal Mixtures

Equation (6.33) has a particular importance in thermodynamic formalism of mixtures; the chemical potential of a component as a function of composition in any mixture is derived from this equation. The first step of this derivation is the definition of an *ideal mixture*. An ideal mixture is a hypothetical multicomponent system, for which the chemical potential of each component has the same functional form as in an ideal gas mixture:

$$\mu_{i,\text{mixture}}(T, P, x_i) = \mu_{i,\text{pure substance}}(T, P) + RT \ln x_i. \quad (6.34)$$

Following the usual simplified notation, we shall omit hereinafter the word “mixture” in the subscript of $\mu_{i,\text{mixture}}(T, P, x_i)$, and also the variable list T, P, x_i – unless it has a particular relevance. In a similar manner, the word “pure substance” in the subscript of $\mu_{i,\text{pure substance}}(T, P)$ and the variables T and P will also be omitted. Instead, we shall use an asterisk to indicate the chemical potential of the pure substance. The simplified equation commonly encountered is:

$$\mu_i = \mu_i^* + RT \ln x_i. \quad (6.35)$$

As the chemical potential p_i is given relative to μ_i^* – the chemical potential of the pure substance – this latter is called the chemical potential of the *reference state*. This means that the reference state is the pure substance at $x_i = 1$.

Let us discuss the properties of an ideal mixture on the basis of (6.35). We can do this by exploring the change of thermodynamic properties of the system when mixing takes place, i.e., a homogeneous mixture is formed from its pure, unmixed components of the appropriate proportions. (Alternatively, we can formulate it as in previous chapters on thermodynamic equilibria. We suppose internal constraints in the initial state that do not allow mixing. By removing these constraints, mixing occurs and a new equilibrium is achieved. We shall describe this new equilibrium state and compare it to the initial state.) These changes are called *properties of mixing*. Instead of a general definition, let us discuss some thermodynamically important quantities. We can start with the chemical potential itself, which we know it changes from μ_i^* to μ_i during mixing. The change due to mixing can be expressed from (6.35) as follows:

$$\Delta_{\text{mix}}\mu_i = \mu_i - \mu_i^* = RT \ln x_i \quad (6.36)$$

Of course, there is nothing new in this statement, but we can easily calculate the *Gibbs potential of mixing* from this equation. From (6.5), we know:

$$G = \sum_{i=1}^K n_i G_i = \sum_{i=1}^K n_i \mu_i. \quad (6.37)$$

Let us divide both sides of this equation by $n = \sum_{i=1}^K n_i$, the total amount of components. On the left side, we get the molar Gibbs potential of the mixture, while on the right side, we can write x_i in place of the amounts of components n_i :

$$g = \sum_{i=1}^K x_i \mu_i. \quad (6.38)$$

Thus, we can write for the Gibbs potential of mixing

$$\Delta_{\text{mix}}g = g - g^* = \sum_{i=1}^K x_i (\mu_i^* + RT \ln x_i) - \sum_{i=1}^K x_i \mu_i^*, \quad (6.39)$$

which results in:

$$\Delta_{\text{mix}}g = RT \sum_{i=1}^K x_i \ln x_i. \quad (6.40)$$

In conclusion, we can state that – in constant-temperature and constant-pressure systems – the formation of a mixture from its pure components is accompanied by a decrease of the Gibbs potential. (The mole fractions x_i are all inferior to 1; thus, the logarithm of each of them is negative.) Based on our knowledge of thermodynamics, we can say that mixing is a spontaneous process.

The *entropy of mixing* can be calculated from (6.11) and the expression (6.35) of the chemical potential:

$$-S_i = \left(\frac{\partial \mu_i}{\partial T} \right)_{P,n} = \frac{\partial}{\partial T} (\mu_i^* + RT \ln x_i) = -S_i^* + R \ln x_i. \quad (6.41)$$

The result is easily obtained:

$$\Delta_{\text{mix}} S = -R \sum_{i=1}^K x_i \ln x_i. \quad (6.42)$$

According to this, mixing is always accompanied by an increase in entropy.

The partial molar volume can also be calculated as the partial derivative of the chemical potential function (*cf.* (6.12)):

$$V_i = \left(\frac{\partial \mu_i}{\partial P} \right)_{T,n} = \frac{\partial}{\partial P} (\mu_i^* + RT \ln x_i) = \left(\frac{\partial \mu_i^*}{\partial P} \right)_{T,n} = V_i^*. \quad (6.43)$$

From this result, we can see that the molar volume does not change when the components are mixed. According to (6.5), it also means that the total volume of the system does not change either, when mixing occurs. We can conclude that the *volume of mixing* of ideal mixtures is zero.

We have seen before that the same relations hold between partial molar quantities as between the corresponding extensive variables. (This is the reason behind the above expressions of S_i and V_i .) By making use of these relations, we can calculate further properties of mixing. From the relation

$$H_i = \mu_i + TS_i \quad (6.44)$$

it follows that

$$\Delta_{\text{mix}} h = \Delta_{\text{mix}} g + T \Delta_{\text{mix}} S, \quad (6.45)$$

Thus, the molar enthalpy of mixing is

$$\Delta_{\text{mix}} h = RT \sum_{i=1}^K x_i \ln x_i - TR \sum_{i=1}^K x_i \ln x_i = 0. \quad (6.46)$$

Accordingly, the enthalpy of the system does not change on mixing, i.e., mixing at constant pressure is accompanied neither by warming nor cooling.

The *molar internal energy of mixing* can be obtained from

$$U_i = \mu_i - PV_i + TS_i \quad (6.47)$$

as

$$\Delta_{\text{mix}}u = \Delta_{\text{mix}}g - P\Delta_{\text{mix}}v + T\Delta_{\text{mix}}s. \quad (6.48)$$

This is also zero; as according to (6.45), $\Delta_{\text{mix}}g + T\Delta_{\text{mix}}s$ is zero, and according to (6.43), $\Delta_{\text{mix}}v$ is also zero. By taking into account the equation

$$F_i = \mu_i - PV_i, \quad (6.49)$$

we can calculate the *molar free energy of mixing* as

$$\Delta_{\text{mix}}f = \Delta_{\text{mix}}g - P\Delta_{\text{mix}}v. \quad (6.50)$$

By considering (6.40) and the above result that $\Delta_{\text{mix}}v = 0$, we obtain the result:

$$\Delta_{\text{mix}}f = RT \sum_{i=1}^K x_i \ln x_i \quad (6.51)$$

In summary, we can state that – when mixing ideal mixtures from the pure components – volume, internal energy, and enthalpy do not change, but entropy is increased, while free energy and the Gibbs potential are decreased.

6.2.3 Alternative Reference States

The chemical potential of the components of an ideal mixture can be written in an alternative form of (6.31) as follows:

$$\mu_i(T, p_i) - \mu_i(T, P) = RT \ln \frac{p_i}{P}. \quad (6.52)$$

The method used in Sect. 6.1.1 to derive this equation leads to a similar result even if we chose another partial pressure as the initial pressure instead of the total pressure P . Thus, if the partial pressure of a component in the mixture changes from $p_{i,1}$ to $p_{i,2}$, (6.52) can be rewritten as follows:

$$\mu_i(T, p_{i,2}) - \mu_i(T, p_{i,1}) = RT \ln \frac{p_{i,2}}{p_{i,1}} \quad (6.53)$$

In an ideal gas mixture – according to (6.25) – we can write

$$p_i = \frac{n_i RT}{V} = \frac{n_i}{V} RT = c_i RT, \quad (6.54)$$

where c_i is the *molar concentration* expressed in the usual mol/dm³ units. Consequently, (6.53) can also be written as follows:

$$\mu_i(T, P, c_{i,2}) - \mu_i(T, P, c_{i,1}) = RT \ln \frac{c_{i,2}}{c_{i,1}}. \quad (6.55)$$

Obviously, at constant pressure we can also write it in another form:

$$\mu_i(T, P, x_{i,2}) - \mu_i(T, P, x_{i,1}) = RT \ln \frac{x_{i,2}}{x_{i,1}}. \quad (6.56)$$

The above equations can be rewritten using a different notation:

$$\mu_i(T, x_i) = \mu_i(T, x_{i,\text{ref}}) + RT \ln \frac{x_i}{x_{i,\text{ref}}}, \quad (6.57)$$

$$\mu_i(T, p_i) = \mu_i(T, p_{i,\text{ref}}) + RT \ln \frac{p_i}{p_{i,\text{ref}}}, \quad (6.58)$$

$$\mu_i(T, c_i) = \mu_i(T, c_{i,\text{ref}}) + RT \ln \frac{c_i}{c_{i,\text{ref}}}. \quad (6.59)$$

In liquid mixtures, the *molality* m_i (the amount of component i per 1 kg solvent, expressed in mol kg⁻¹ units) is also *nearly* proportional to a good approximation to the mole fraction, especially at low m_i values. (This is one of the reasons to speak about *dilute solutions*.) Thus, we can write a fourth equation:

$$\mu_i(T, P, m_i) = \mu_i(T, P, m_{i,\text{ref}}) + RT \ln \frac{m_i}{m_{i,\text{ref}}}. \quad (6.60)$$

The four equations above suggest that the chemical potential of a mixture component can be given relative to any reference state. The concentration of the reference state, as well as that of the actual state, can be given either as partial pressure, or mole fraction, or molar concentration, or molality. (Obviously, partial pressure is only relevant in gases, while molality in dilute solutions.) However, it is important to emphasize that the *definition* of an ideal mixture is (6.35), using *mole fraction* as concentration. Consequently, the other expressions above can only be used for accurate calculations if the concentration used is strictly *proportional* to the mole fraction. (As we have seen, in gas mixtures, the partial pressure p_i and the molar concentration c_i fulfill this condition.)

Let us check the general applicability of the concentrations c_i and m_i from this point of view. As to c_i , we can write the amount of component i in the numerator, while we can replace the volume V in the denominator by the total mass of the mixture divided by the density ρ . (The density is then written in the numerator. M_j is the molar mass of component j .) We can readily simplify by the total amount n :

$$c_i = \frac{\rho x_i n}{n \sum_{j=1}^K x_j M_j} = \frac{\rho x_i}{\sum_{j=1}^K x_j M_j}. \quad (6.61)$$

Let us rewrite the equation by separating component 1 from all the other components in the denominator and express the concentration of this component:

$$c_1 = x_1 \frac{\rho}{x_1 M_1 + \sum_{j=2}^K x_j M_j}. \quad (6.62)$$

Observing this result, we can see that c_i is only proportional to x_i if the density ρ does not change with the composition, and if the molar mass M_1 of component 1 is identical to the mean molar mass of the other components. Otherwise, c_1 is only proportional to a good approximation to x_1 if c_1 is small.

The molality m_i – which is the amount of component i dissolved in 1000 g of the solvent – is used to express concentration in liquid solutions. In many cases, the “solvent” means all the other components except for component 1; thus, we can write for the molality m_1 :

$$m_1 = x_1 \frac{1000}{\sum_{j=2}^K x_j M_j}. \quad (6.63)$$

(The number 1000 in the numerator appears as a consequence of writing the molar masses M_j in *gram/mol units*.) Let us suppose that the composition of the solvent does not change; thus, we can treat it as a single component. By denoting its total amount by n_2 , its mole fraction can be calculated as $x_2 = n_2/(n_1 + n_2)$. By taking into account that $x_2 = 1 - x_1$, we can rewrite the above equation as follows:

$$m_1 = \frac{1000}{M_2} \frac{x_1}{1 - x_1}. \quad (6.64)$$

From this result, we can see that the proportionality of m_1 to x_1 holds only to the same approximation as the proportionality of the ratio $x_1/(1 - x_1)$ to x_1 – which is a good approximation only if $x_1 \ll 1$, i.e., in dilute solutions.

By summing up the above results, we can say that the definition of an ideal mixture

$$\mu_i(T, P, x_i) = \mu_i^*(T, P) + RT \ln \frac{x_i}{1} \quad (6.65)$$

can be replaced in gaseous mixtures by

$$\mu_i(T, P, p_i) = \mu_i(T, P, p_{i,\text{ref}}) + RT \ln \frac{p_i}{p_{i,\text{ref}}} \quad (6.66)$$

to give exact results. In case of low concentrations of the species i , we can also use the following equations to a good approximation:

$$\mu_i(T, P, c_i) = \mu_i(T, P, c_{i,\text{ref}}) + RT \ln \frac{c_i}{c_{i,\text{ref}}}, \quad (6.67)$$

$$\mu_i(T, P, m_i) = \mu_i(T, P, m_{i,\text{ref}}) + RT \ln \frac{m_i}{m_{i,\text{ref}}}. \quad (6.68)$$

6.2.4 Activity and Standard State

Equations (6.65) – (6.68) are rather similar to each other; in each of them, the logarithm of the concentration ratio multiplied by RT is added to the chemical potential of the reference state. The concentration ratio can be related to the ratio of the activities. Activity is defined by the following equation:

$$\mu_i = RT \ln \lambda_i. \quad (6.69)$$

The quantity λ_i is called *absolute activity*. Obviously, the difference of the chemical potentials is related to the ratio of the absolute activities:

$$\mu_2 - \mu_1 = RT \ln \frac{\lambda_2}{\lambda_1}. \quad (6.70)$$

The particular ratio

$$a_i = \frac{\lambda_i}{\lambda_{i,\text{ref}}} \quad (6.71)$$

is called the *relative activity with respect to the reference state*. In the light of this definition, (6.65)–(6.68) can be written in the same general form:

$$\mu_i = \mu_{i,\text{ref}} + RT \ln a_i. \quad (6.72)$$

It is common practice to use μ_i^\ominus instead of $\mu_{i,\text{ref}}$, which we will also adopt in this book.³ If there is no ambiguity, this simple notation is used to formulate the composition-dependent chemical potential:

$$\mu_i = \mu_i^\ominus + RT \ln a_i \quad (6.73)$$

³The symbol \ominus has been devised by Samuel Plimsoll (1825–1898) as a safe load line on ships to avoid overloading. Plimsoll was a liberal Member of Parliament and succeeded to prescribe the safe load line in a bill. IUPAC introduced the “plimsoll sign” to denote the reference state in 1970, but it considers the sign \ominus and \circ as equally acceptable. In the rest of the book, we shall use \ominus .

The quantity a_i is the ratio of the value of a composition variable (such as x_i , p_i , c_i , or m_i) and the value of the same variable in the reference state, which is identical to the respective ratio of absolute activities λ_i .

A more informative but not quite correct formulation contains the composition variable itself instead of the activity a_i , and we have to *imagine* a division by the value of the composition variable in the reference state. In other words, we can say that we consider the concentration (or partial pressure) of the reference state as unit and the concentration (or partial pressure) in the formula is the *measured value* on this scale – which is identical to the relative activity defined in (6.71). (Of course, this is only true if the concentration used is proportional to the mole fraction.) This formulation is quite commonly used; thus, we summarize different possibilities in Table 6.1. If there is no ambiguity, we shall use this simplified notation in this book.

Of the “substitutes” for relative activities shown in the table, there is no problem with the mole fraction x_i as it is a dimensionless quantity. In case of the molar concentration c_i or the molality m_i , the reference state is almost always 1 mol/dm^{-3} or 1 mol kg^{-1} ; thus, the argument of the logarithm function is the measured value in mol dm^{-3} or mol kg^{-1} unit. In case of the partial pressure p_i , the situation is more complicated. The usual reference state is the pure gas at atmospheric pressure which, in SI units, is not 1 but 101 325 Pa. Thus, the correct value of the argument of the logarithm function is p_i/p^\ominus , i.e., “ p_i ” should be understood as $p_i/101\,325 \text{ Pa}$. (It should be noted that the reference pressure was originally *not* 101 325 Pa but 1 atm so that the partial pressure given in atm units was also simply the measured value in atm units.)

Reference state concentrations and pressure shown in Table 6.1 are particular values according to the 1970 recommendations of IUPAC. According to this recommendation, the pressure 101 325 Pa is called *standard pressure*, the concentration 1 mol dm^{-3} is called *standard concentration*, and the molality 1 mol kg^{-1} is called *standard molality*. The standard value of the mole fraction is of course 1. As to the pressure, IUPAC formulated a recommendation already in 1985 that the standard pressure should be changed from the “old” 1 atm (i.e., 101 325 Pa) to the simpler value of 1 bar = 10^5 Pa , but this recommendation has not really been

Table 6.1 Actual forms of the general equation $\mu_i = \mu_i^\ominus + RT \ln a_i$ in case of relative activities a_i defined in terms of different composition variables in *ideal mixtures*, and the respective reference states. The symbols p_i , c_i , and m_i always stand for the measured value of the respective quantity in units of the value of the reference state, i.e., for the ratios p_i/p^\ominus , c_i/c^\ominus , and m_i/m^\ominus

System	Equation	Meaning of μ_i^\ominus	Comment
Every mixture	$\mu_i = \mu_i^\ominus + RT \ln x_i$	μ_i of the pure component	Always exact
Gas mixtures	$\mu_i = \mu_i^\ominus + RT \ln p_i$	μ_i of the pure component at pressure p^\ominus (p^\ominus is usually 101,325 Pa)	Always exact
Liquid solutions ideal gas mixtures	$\mu_i = \mu_i^\ominus + RT \ln c_i$	μ_i of the pure component at concentration c^\ominus (c^\ominus is usually 1 mol/dm^3)	Approximately valid in dilute solutions
Liquid solutions	$\mu_i = \mu_i^\ominus + RT \ln m_i$	μ_i of the pure component at concentration m^\ominus (m^\ominus is usually 1 mol kg^{-1})	Approximately valid in dilute solutions

implemented in practice. Anyway, we should be careful to check what is the standard pressure when referring to thermodynamic tables or databases.

The above-mentioned particular reference states are called *standard states*, and the symbol μ_i^\ominus refers to these states. This is the reason to call μ_i^\ominus the *standard chemical potential*. This name will have a more important role in case of real mixtures, but at the same time it loses its property of referring to a physically existing mixture. The property of the physical existence of the standard state holds only in ideal mixtures.

6.3 Thermodynamics of Real Mixtures

Similarly to ideal gases, ideal mixtures do not exist. However, as the fundamental equation of an ideal gas might be a good approximation of the thermodynamic properties of a real gas, the thermodynamic description of ideal mixtures can also be considered as an approximation. The ideal gas equation of state can be mathematically exact in limiting cases (e.g., at zero pressure). Similarly, there are limiting cases where thermodynamic formulae describing ideal mixtures are also mathematically exact. The analogy between an ideal gas and an ideal solution also extends to the actual treatment of real gases and real mixtures; on the analogy of fugacity correcting the ideal gas equation of state for real gases, a similar modification of activity corrects the formalism of ideal mixtures to describe the behavior of real mixtures. This modification is described in the next section.

6.3.1 Mixtures of Real Gases

Let us recall the expression for the chemical potential as a function of the partial pressure p_i in an ideal mixture, formulated in (6.30):

$$\mu_i(T, p_i) = \mu_i(T, P) + \int_P^{p_i} V_i \, dp.$$

If component i does not behave as an ideal gas, its partial molar volume V_i is not identical to RT/p ; thus, the equation found in Table 6.1,

$$\mu_i^{\text{id}}(T, p_i) = \mu_i^\ominus(T, P^\ominus) + RT \ln \frac{p_i}{P^\ominus} \quad (6.74)$$

does not apply. Let us write equation (6.30) for both a real and an ideal mixture, and subtract the one for the real mixture from the other:

$$\mu_i(T, p_i) - \mu_i^{\text{id}}(T, p_i) = \mu_i^{\ominus}(T, P^{\ominus}) - \mu_i^{\ominus \text{id}}(T, P^{\ominus}) + \int_{P^{\ominus}}^{p_i} \left(V_i - \frac{RT}{p} \right) dp. \quad (6.75)$$

The difference $\mu_i(T, p_i) - \mu_i^{\text{id}}(T, p_i)$ is called *excess chemical potential* and is denoted by μ_i^{E} . This excess chemical potential can be considered as the “deviation from the ideal behavior”. Let us fix the reference state of the real mixture concerning component i as the reference state of an ideal mixture; *i. e.* according to the identity $\mu_i^{\ominus}(T, P^{\ominus}) = \mu_i^{\ominus \text{id}}(T, P^{\ominus})$. In this case, the deviation from the ideal behavior is fully accounted for by the integral in the last term of (6.75). We know of gases that the deviation from the ideal gas behavior diminishes as the pressure goes to zero, and we also expect this behavior in a gas mixture for all the components. Consequently, at small enough pressure, even a real gas mixture behaves as an ideal mixture. In the light of this limiting behavior, let us choose the pressure P^{\ominus} of the reference state as zero. In this case, we can be certain that the values of μ_i^{\ominus} and $\mu_i^{\ominus \text{id}}$ should be identical, their difference is zero, and the integration should be carried out from the lower limit of zero pressure:

$$\mu_i(T, p_i) - \mu_i^{\text{id}}(T, p_i) = \int_0^{p_i} \left(V_i - \frac{RT}{p} \right) dp. \quad (6.76)$$

The integral on the right-hand side is identical to the function $RT \ln \varphi_i$, which can be calculated using (4.95), where φ_i is the *fugacity coefficient*⁴ of component i . Let us substitute into the above equation the expression of the chemical potential $\mu_i^{\text{id}}(T, p_i)$ from (6.74) and replace the integral by $RT \ln \varphi_i$. By rearranging, we get:

$$\mu_i(T, p_i) = \mu_i^{\ominus}(T, P^{\ominus}) + RT \ln \frac{p_i}{P^{\ominus}} + RT \ln \varphi_i \quad (6.77)$$

This can be rewritten in the simpler form:

$$\mu_i(T, p_i) = \mu_i^{\ominus}(T, P^{\ominus}) + RT \ln \frac{\varphi_i p_i}{P^{\ominus}} \quad (6.78)$$

We should keep in mind that the above expression has been obtained by substitution of the chemical potential of an *ideal* mixture; thus, the standard chemical potential of the ideal mixture $\mu_i^{\ominus}(T, P^{\ominus})$ is “inherited”. Accordingly, $\mu_i^{\ominus}(T, P^{\ominus})$ is the chemical potential of component i in a hypothetical *ideal mixture* at the given temperature and the reference pressure:

⁴Fugacity was introduced by the American chemist Gilbert Newton Lewis (1875–1946) in 1908 to calculate the chemical potential of components in gas mixtures. The quantity $f_i = \varphi_i p_i$ should properly be called as *partial fugacity* (in analogy to the partial pressure p_i) as the fugacity of a component in a mixture is typically not identical to the fugacity of the same pure component at the pressure p_i . However, this name is not used and we shall not use it either in this book. The word *fugacity* is coined from the Latin *fuga* = escape and the word *capacity* which is also of Latin origin, thus referring to the “capacity to escape” of the gas.

$$\mu_i^\ominus(T) = \lim_{p_i \rightarrow 0} \left[\mu_i(T, p_i, \varphi_i, x) - RT \ln \frac{\varphi_i p_i}{P^\ominus} \right]. \quad (6.79)$$

We may interpret this the following way. The actual partial pressure p_i in the numerator contains the corrected value $\varphi_i p_i$, and the standard chemical potential $\mu_i^\ominus(T)$ is to be understood so that, though it is the chemical potential at the pressure $\varphi_i p_i$ which is equal to P^\ominus (as the fraction is 1 and the logarithm is zero in that case), its actual value reflects an ideal behavior of the gas mixture at the pressure P^\ominus . Due to the value of the standard at the limit of zero pressure, it does *not* depend on pressure, only on temperature – which is the reason not to show pressure as its argument. The value of the standard at any reference pressure P^\ominus can be obtained by extrapolation to this pressure. The correction factor φ_i takes into account the deviation from the ideal behavior at any pressure. We can say that the standard chemical potential obtained at extremely low pressures is always extrapolated to the actual pressure P^\ominus according to the expression valid for ideal mixtures. This interpretation is visualized in Fig. 6.2.

Following Lewis, the “effective (partial) pressure” $\varphi_i p_i$ is called *fugacity*, and it can be denoted also by f_i . Accordingly, the quantity φ_i is called the *fugacity coefficient*. If the existence of the limit at zero pressure and the possibility to calculate the fugacity coefficient using (4.95) are not to be proved, the chemical potential of a real gas mixture can more easily be derived. The chemical potential can be written as follows:

$$\mu_i(T, p_i) = \mu_i^{\text{id}}(T, p_i) + \mu_i^{\text{E}}(T, p_i) = \mu_i^\ominus(T) + RT \ln \frac{p_i}{P^\ominus} + \mu_i^{\text{E}}(T, p_i). \quad (6.80)$$

Let us rewrite the excess chemical potential μ_i^{E} as $RT \ln \varphi_i$:

$$\mu_i(T, p_i) = \mu_i^\ominus(T) + RT \ln \frac{p_i}{P^\ominus} + RT \ln \varphi_i \quad (6.81)$$

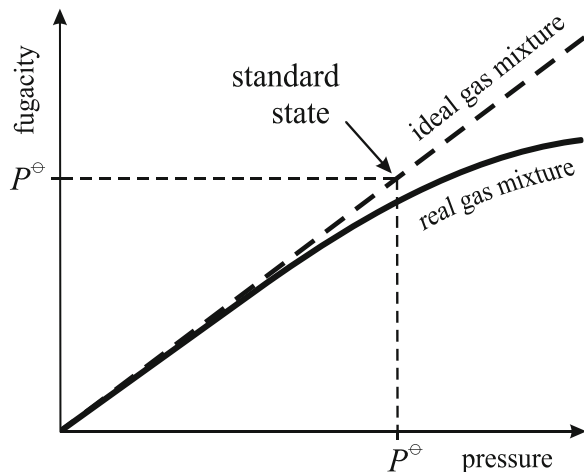

Fig. 6.2 Interpretation of the standard state if the chemical potential of a component in real gas mixtures is given as a function of fugacity

By rearranging the equation, we get:

$$\mu_i(T, p_i) = \mu_i^\ominus(T) + RT \ln \varphi_i \left(\frac{p_i}{p^\ominus} \right). \quad (6.82)$$

As we can see, we have kept *formally* (6.74) valid for ideal mixtures; we “only” inserted a correction factor. This “solution” only seems to be simple or elegant, as the correction factor φ_i should be calculated anyway, according to (6.76) and the standard chemical potential should also be calculated according to (6.79). However, *to write* equations is definitely simple this way; in (6.82), it is the ideal activity p_i/p^\ominus , which is simply multiplied by the correction factor φ_i . This is the only difference with respect to the expression of the ideal mixture. Formally, it is nothing but a mere multiplication of the relative activity in the expression of the chemical potential of an ideal mixture by the excess absolute activity λ_i^E defined as follows:

$$\mu_i^E(T, p_i) = RT \ln \lambda_i^E. \quad (6.83)$$

Obviously, λ_i^E is identical with the correction factor φ_i .

In further sections, we give a similar formula according to formal changes explained above for the chemical potential as a function of other composition variables.

6.3.2 The Chemical Potential in Terms of Mole Fractions

Partial molar quantities have an important role in the thermodynamic description of mixtures. According to (6.7), these quantities can be given as a function of the mole fractions x_i . Let us return our attention to the chemical potential as a function of the mole fraction. Following the procedure outlined at the end of the previous section, let us write the chemical potential based on a correction factor related to the excess chemical potential μ_i^E and define an appropriate standard chemical potential. Thus, we can write (6.35) for a real mixture in the following form:

$$\mu_i = \mu_i^* + RT \ln x_i + \mu_i^E. \quad (6.84)$$

By substituting $\mu_i^E = RT \ln \lambda_i^E$ and denoting λ_i^E by f_i , we get the following equation:

$$\mu_i = \mu_i^* + RT \ln f_i x_i. \quad (6.85)$$

The quantity $a_i = f_i x_i$ is called *relative activity*, while f_i is called *relative activity coefficient*. (Unfortunately, the commonly used symbol f_i coincides with that of fugacity. One should be careful to distinguish between the two quantities.)

In fact, the term relative activity is used in a broader sense. The activity f_i x_i defined in (6.85) can be called – in a more specific sense – as the *activity* (or f_i as the activity coefficient) *referenced to the pure substance*. (An alternative name – also specific for this case – is the *activity referenced to Raoult's law*. The origin of this name is explained in Sect. 7.4.) It is obvious that the standard chemical potential μ_i^* in (6.85) is the chemical potential of the pure component at the given temperature and pressure; if the mole fraction x_i goes to 1, the mixture exhibits a behavior that is closer and closer to the ideal behavior; thus, the activity coefficient also goes to 1, and μ_i goes to the chemical potential of the pure substance.

It is important to note that the equation

$$\mu_i^E = RT \ln f_i \quad (6.86)$$

can be used to calculate f_i if we know the fundamental equation of the system. From the fundamental equation we can calculate μ_i , and by rearranging (6.84) we directly obtain the excess chemical potential:

$$\mu_i^E = \mu_i - \mu_i^* - RT \ln x_i. \quad (6.87)$$

Though (6.84) has a major importance in thermodynamic description of mixtures, its use is not always practical. In case of a mixture component which does not exist in the same physical state as the mixture, it is not sensible to use this equation. In case of ethanol–water mixtures, both components exist in the same state as the mixture (under ambient conditions both are liquid). However, dissolving oxygen or sucrose (table sugar) in water, the mixture is normally liquid, while pure oxygen is a gas and pure sugar is a solid. Obviously, it is not practical to give the chemical potential of these components referenced to the pure gas or the pure solid. To come around this problem, a practical solution is to reference the chemical potential to the concentration $x_i = 0$ instead of $x_i = 1$. This reference state is not to be interpreted as a “mixture” which does not contain the component in question; it rather refers to the chemical potential of the component in the mixture *extrapolated to zero concentration*. (This standard state is similar to that of the nonideal gas mixtures at zero pressure.) The chemical potential thus referenced can be written as follows:

$$\mu_i = \mu_{x,i}^\ominus + RT \ln \gamma_{x,i} x_i. \quad (6.88)$$

The quantity $a_i = \gamma_{x,i} x_i$ is frequently referred to as *rational activity*⁵ while $\gamma_{x,i}$ is called *rational activity coefficient*. The mixture is considered as ideal concerning component i if it is infinitely dilute with respect to this component. The symbol $\mu_{x,i}^\ominus$ is the *hypothetical* chemical potential of the “pure” component i in a state which is identical to that of its state in an infinitely dilute solution (somewhat similar to the

⁵The name is based on the word *ratio*, referring to the mole fraction as a ratio of amounts.

case shown in Fig. 6.2.). It is obvious that such a liquid does not exist; this is the reason that the standard state is a hypothetical one. Mathematically, we can write an exact expression to calculate this standard chemical potential:

$$\mu_{i,x}^{\ominus}(T,P) = \lim_{x_i \rightarrow 0} [\mu_i(T,P,x_i) - RT \ln x_i]. \quad (6.89)$$

However, this simply means that writing the constant $\mu_{x,i}^{\ominus}$ in (6.88), it exactly yields the correct value of the chemical potential. Thus, $\mu_{x,i}^{\ominus}$ is not the chemical potential of the reference state (as such a state cannot be realized and does not exist). It is simply *a composition-independent constant* in (6.88) yielding the chemical potential. Despite this property, $\mu_{x,i}^{\ominus}$ is a state function. As we shall see later, it has a major role in describing equilibria in multicomponent systems.

6.3.3 The Chemical Potential in Terms of Solute Concentration

In the chemical praxis, there are many reactions that do not occur between pure substances but between substances dissolved in a solvent. The composition of these solutions is mostly given in terms of molar concentration or molality, instead of mole fractions, and the chemical potential as a function of these solute concentrations is usually preferred. As explained in Sect. 6.1.3, the molar concentration c_i depends also on the density (which in turn depends also on temperature), and its proportionality to the mole fraction only holds to an approximation depending on the ratio of the molar masses of components; thus, the molality m_i is more frequently used in thermodynamics.

To express the chemical potential in real mixtures as a function of molality, we can also use the “formal procedure” used before:

$$\mu_i(T,P,m_i,x) = \mu_{m,i}^{\ominus}(T,P) + RT \ln \frac{m_i}{m_i^{\ominus}} + \mu_i^E(T,P,m_i,x). \quad (6.90)$$

By omitting the variables T , P , m_i , and x , and using $\gamma_{m,i}$ instead of λ_i^E in the expression $\mu_i^E = RT \ln \lambda_i^E$, we get:

$$\mu_i = \mu_{m,i}^{\ominus} + RT \ln \gamma_{m,i} \left(\frac{m_i}{m_i^{\ominus}} \right). \quad (6.91)$$

The product $\gamma_{m,i} \left(\frac{m_i}{m_i^{\ominus}} \right)$ is often called *practical activity*, while $\gamma_{m,i}$ is called *practical activity coefficient*. Another name is the activity (activity coefficient) *with respect to molality*. The standard state is *hypothetical* also in this case and can be given as the limit at zero concentration:

$$\mu_{m,i}^{\ominus}(T,P) = \lim_{m_i \rightarrow 0} \left[\mu_i(T,P,m_i) - RT \ln \frac{m_i}{m_i^{\ominus}} \right]. \quad (6.92)$$

The expression of the chemical potential as a function of molar concentration can be derived in a similar way. In the expression $\mu_i^E = RT \ln \lambda_i^E$, λ_i^E is then replaced by $\gamma_{c,i}$; thus, we get the following expression:

$$\mu_i = \mu_{c,i}^\ominus + RT \ln \gamma_{c,i} \left(\frac{c_i}{c_i^\ominus} \right). \quad (6.93)$$

Accordingly, the product $\gamma_{c,i}(c_i/c_i^\ominus)$ is often called *activity with respect to (molar) concentration*, while $\gamma_{c,i}$ is called *activity coefficient with respect to (molar) concentration*. The *hypothetical* standard state can be given as the limit at zero concentration:

$$\mu_{c,i}^\ominus(T, P) = \lim_{c_i \rightarrow 0} \left[\mu_i(T, P, m_i) - RT \ln \frac{c_i}{c_i^\ominus} \right]. \quad (6.94)$$

6.3.4 Activity and Standard State: An Overview

The use of activities as variables is inevitable in the thermodynamics of mixtures, but they should be used with care, as we can foresee from the above discussions. As we have seen, the short term activity is used for relative activities when the reference state is the pure substance, and also when it is the limiting value at zero concentration. In addition, molality and molar concentration can also be used as composition variable in addition to mole fraction, without changing the short term “activity”. In many cases, there is no hint in the notation of the activity coefficient concerning the reference concentration, which is the same in case of the relative activity as well. In most cases, only a general form

$$\mu_i = \mu_i^\ominus + RT \ln a_i \quad (6.95)$$

is only given. Of course, we should always make it clear what are the actual reference concentration and the standard chemical potential. Let us summarize the most important characteristics of different activities in a table and explore their interrelations.

The value of the chemical potential – being a state function – should be independent of the reference state and the unit of concentration. Thus, we can always write the equality of the chemical potentials in different reference systems if they refer to the mixture of the same composition. Let us consider first the equality based on (6.85) and (6.88):

$$\mu_i^*(T, P) + RT \ln f_i x_i = \mu_{x,i}^\ominus(T, P) + RT \ln \gamma_{x,i} x_i \quad (6.96)$$

Table 6.2 Characteristics of the activity a_i and the standard chemical potential μ_i^\ominus in the expression $\mu_i = \mu_i^\ominus + RT \ln a_i$ valid for real mixtures in case of different composition variables and reference states

Activity a_i	Name	Meaning of the standard μ_i^\ominus	Condition
$f_i x_i$	Relative activity (activity referenced to Raoult's law)	$\mu_i^*(T, P)$ (chemical potential of the pure substance)	At any concentration $0 \leq x_i \leq 1$
$\gamma_{x,i} x_i$	Rational activity (activity referenced to Henry's law)	$\mu_{i,x}^\ominus(T, P) = \lim_{x_i \rightarrow 0} [\mu_i(T, P, x_i) - RT \ln x_i]$ (chemical potential of the hypothetical pure substance in the state identical to that at infinite dilution)	At any concentration in existing mixtures
$\gamma_{m,i} \left(\frac{m_i}{m_i^\ominus}\right)$	Molality basis activity	$\mu_{m,i}^\ominus(T, P) = \lim_{m_i \rightarrow 0} \left[\mu_i(T, P, m_i) - RT \ln \frac{m_i}{m_i^\ominus} \right]$ (chemical potential of the hypothetical ideal mixture at concentration $m_i^\ominus = 1 \text{ mol kg}^{-1}$ in the state identical to that at infinite dilution)	In solutions
$\gamma_{c,i} \left(\frac{c_i}{c_i^\ominus}\right)$	Concentration basis activity	$\mu_{c,i}^\ominus(T, P) = \lim_{c_i \rightarrow 0} \left[\mu_i(T, P, c_i) - RT \ln \frac{c_i}{c_i^\ominus} \right]$ (chemical potential of the hypothetical ideal mixture at concentration $c_i^\ominus = 1 \text{ mol dm}^{-3}$ in the state identical to that at infinite dilution)	In solutions
$\varphi_i \left(\frac{p_i}{p^\ominus}\right)$	Fugacity	$\mu_i^\ominus(T) = \lim_{p_i \rightarrow 0} \left[\mu_i(T, p_i, \varphi_i, x) - RT \ln \frac{\varphi_i p_i}{p^\ominus} \right]$ (chemical potential of the hypothetical ideal mixture at a reference pressure $\varphi_i p_i = P^\ominus$)	In every gaseous mixture

The difference of the standard chemical potentials μ_i^* and $\mu_{x,i}^\ominus$ can be expressed from this as follows:

$$\mu_i^* - \mu_{x,i}^\ominus = RT \ln \gamma_{x,i} x_i - RT \ln f_i x_i = RT \ln \frac{\gamma_{x,i}}{f_i}. \quad (6.97)$$

Both μ_i^* and $\mu_{x,i}^\ominus$ are independent of the concentration; thus, the ratio $\gamma_{x,i}/f_i$ is also independent of concentration; its value is always

$$\frac{\gamma_{x,i}}{f_i} = e^{\frac{\mu_i^* - \mu_{x,i}^\ominus}{RT}}. \quad (6.98)$$

Based on the equation, we can say that, for a pure component (for which $x_i = 1$ and $f_i = 1$), the value of $\gamma_{x,i}$ is exactly the exponential on the right-hand side. Similarly, for an infinitely dilute solution (for which $x_i = 0$ and $\gamma_{x,i} = 1$), the value of f_i is the reciprocal of the exponential:

$$x_i = 1: \quad f_i = 1 \quad \text{and} \quad \gamma_{x,i} = e^{\frac{\mu_i^* - \mu_{x,i}^\ominus}{RT}}; \quad x_i = 0: \quad \gamma_{x,i} = 1 \quad \text{and} \quad f_i = e^{-\frac{\mu_i^* - \mu_{x,i}^\ominus}{RT}} \quad (6.99)$$

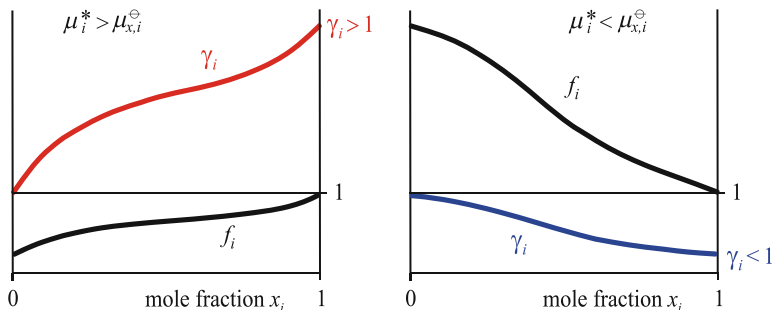

Fig. 6.3 Dependence of the activity coefficient f_i referenced to Raoult's law and that of γ_i referenced to Henry's law on concentration of the component i . The relative placement of the curves depends on the sign of the difference of the standard chemical potentials μ_i^* (of the pure component) and $\mu_{x,i}^\ominus$ (of the state of infinite dilution)

Thus, if $\mu_i^* - \mu_{x,i}^\ominus$ is positive, f_i is minimal at $x_i = 0$, and it increases with increasing concentration in case of a monotonical change until it reaches unit at $x_i = 1$. Accordingly, $\gamma_{x,i}$ starts from unit at $x_i = 0$, and it increases proportionally to f_i . This behavior is illustrated in the left panel of Fig. 6.3. In case of a negative $\mu_i^* - \mu_{x,i}^\ominus$, the concentration dependence of the activity coefficients is shown in the right panel of the figure.

Figure 6.4 shows more explicitly the meaning of $\gamma_{x,i}$ and f_i concerning the concentration dependence of the chemical potential. By rearranging (6.85) and (6.88), we obtain the following relations:

$$\mu_i - RT \ln x_i = \mu_i^* + RT \ln f_i; \quad \mu_i - RT \ln x_i = \mu_{x,i}^\ominus + RT \ln \gamma_{x,i} \quad (6.100)$$

From these relations, it is obvious that the quantity $\mu_i - RT \ln x_i$ is obtained by adding $RT \ln \gamma_{x,i}$ to $\mu_{x,i}^\ominus$, and also by adding $RT \ln f_i$ to μ_i^* . As f_i happens to be less than or equal to unit ($f_i \leq 1$) in the illustration in Fig. 6.4, this addition diminishes the chemical potential with respect to μ_i^* , as it can be seen in the figure.

Summing up we can say that activities referenced to the pure component and to infinite dilution in case of a real mixture *are always different*, and the respective *standard chemical potentials are also different*. If the mixture exists in the entire concentration range (i.e., in case of unlimited miscibility), both standard chemical potentials can be determined from thermodynamic data. In this case, knowing one of the activity coefficients $\gamma_{x,i}$ and f_i , the other one can be determined using (6.98). However, in case of an ideal mixture, both $\gamma_{x,i}$ and f_i are identically unit; thus, $\mu_{x,i}^\ominus = \mu_i^*$ also holds.

Activities referenced to infinite dilution exhibit a similar behavior relative to activities referenced to the pure substance also if they are expressed on a molality or molar concentration basis instead of a mole fraction basis. As we know (cf. Sect. 6.2.3), standard concentrations are different in case of different concentration

Fig. 6.4 A possible shape of the quantity $\mu_i - RT \ln x_i$ as a function of the mole fraction x_i , if $\mu_i^* > \mu_{x,i}^\ominus$. The difference of this quantity from μ_i^* – the chemical potential of the pure component – is $RT \ln f_i$, while from $\mu_{x,i}^\ominus$ – the chemical potential referenced to infinite dilution – it is $RT \ln \gamma_i$

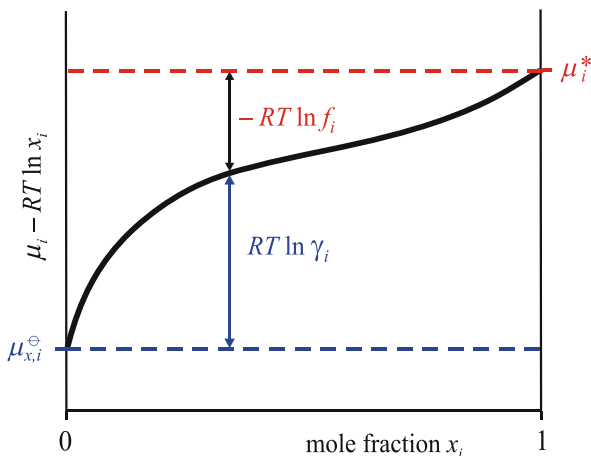

bases if activities are referenced to infinite dilution. As neither molality nor molar concentration are strictly proportional to mole fraction, the activity coefficient of the same mixture will generally be different if expressed in different concentration bases. The principle of comparing them is still the same; the value of the chemical potential in an actual mixture is always the same, independently of the eventual form of the chemical potential function.

Applying this principle for activities on molality and mole fraction basis referenced to infinite dilution, we can write the equality based on (6.88) and (6.91):

$$\mu_{x,i}^\ominus(T, P) + RT \ln \gamma_{x,i} x_i = \mu_{m,i}^\ominus(T, P) + RT \ln \gamma_{m,i} \tilde{m}_i, \quad (6.101)$$

where \tilde{m}_i is the molality divided by the standard molality m_i^\ominus , i.e., the *measured value* in units of the standard molality – which is identical to the relative activity defined in (6.91). By rearranging the above equation, we get:

$$RT \ln \frac{\gamma_{m,i} \tilde{m}_i}{\gamma_{x,i} x_i} = \mu_{x,i}^\ominus(T, P) - \mu_{m,i}^\ominus(T, P). \quad (6.102)$$

The difference of the two standard chemical potentials can be obtained by the limit $x_i \rightarrow 0$, i.e., in sufficiently dilute solutions where both $\gamma_{x,i}$ and $\gamma_{m,i}$ are identically unit; thus:

$$\mu_{x,i}^\ominus(T, P) - \mu_{m,i}^\ominus(T, P) = RT \ln \frac{\tilde{m}_i}{x_i}. \quad (6.103)$$

By applying this principle for activities on molality and mole fraction basis referenced to infinite dilution, we can write the equality based on (6.88) and (6.91):

By taking into account the relation of molality to mole fraction expressed in (6.63) as

$$m_1 = x_1 \frac{1000}{\sum_{j=2}^K x_j M_j},$$

the difference of the standard chemical potentials can be written as follows:

$$\mu_{x,i}^{\ominus}(T, P) - \mu_{m,i}^{\ominus}(T, P) = RT \ln \frac{1000}{\sum_{\forall j \neq i} x_j M_j}. \quad (6.104)$$

Let us consider the mixture to be a binary one and denote the solvent by the subscript 0. By taking into account that at infinite dilution $x_0 \rightarrow 1$, we can write the difference as follows:

$$\mu_{x,i}^{\ominus}(T, P) - \mu_{m,i}^{\ominus}(T, P) = RT \ln \frac{1000}{M_0} \quad (6.105)$$

(Though the mixture is binary here, with component i as solute and all other components as solvent, we still keep the subscript i to denote the solute component as it could be *any component*.)

According to (6.102), we can write:

$$RT \ln \frac{\gamma_{m,i} \tilde{m}_i}{\gamma_{x,i} x_i} = RT \ln \frac{1000}{M_0}. \quad (6.106)$$

This can be rearranged to

$$RT \ln \frac{\gamma_{m,i}}{\gamma_{x,i}} = RT \ln \frac{1000 x_i}{\tilde{m}_i M_0}. \quad (6.107)$$

We can substitute m_i from (6.64), changing the notation accordingly, to get:

$$\frac{\gamma_{m,i}}{\gamma_{x,i}} = 1 - x_i. \quad (6.108)$$

From this result we can see that – for dilute solutions, until we accept the approximation that x_i is much smaller than 1 – the activity $\gamma_{m,i}$ on molality basis and the activity $\gamma_{x,i}$ on mole fraction basis (both referenced to infinite dilution) are approximately equal. However, if x_i is not small enough to be neglected compared to one, this equality does not hold. Furthermore, we can state that, if a mixture is *ideal* according to the thermodynamic definition (i.e. if the concentration is expressed in mole fraction), at concentrations not negligible compared to one, the

activity coefficient $\gamma_{m,i}$ on molality basis is *not unit*. Thus, “ideality” on a mole fraction basis does not coincide with “ideality” on molality basis.

Similarly to the above comparison, we can write for the activities on molarity basis and that on mole fraction basis, accordingly to (6.88) and (6.93):

$$\mu_{x,i}^{\ominus}(T, P) - \mu_{c,i}^{\ominus}(T, P) = RT \ln \frac{\gamma_{c,i} \tilde{c}_i}{\gamma_{x,i} x_i}, \quad (6.109)$$

Here, \tilde{c}_i is the molarity divided by the standard molarity c_i^{\ominus} , i.e., the *measured value* in units of the standard molarity – which is identical to the relative activity defined in (6.93). At the limit $x_i \rightarrow 0$, i.e., in sufficiently dilute solutions where both $\gamma_{x,i}$ and $\gamma_{m,i}$ are identically unit:

$$\mu_{x,i}^{\ominus}(T, P) - \mu_{c,i}^{\ominus}(T, P) = RT \ln \frac{\tilde{c}_i}{x_i}. \quad (6.110)$$

By substituting

$$c_i = x_i \frac{\rho}{x_i M_i + \sum_{\forall j \neq i}^K x_j M_j}$$

from (6.62), we get:

$$\mu_{x,i}^{\ominus}(T, P) - \mu_{c,i}^{\ominus}(T, P) = RT \ln \frac{\rho}{x_i M_i + \sum_{\forall j \neq i}^K x_j M_j}. \quad (6.111)$$

By considering the mixture as a binary one and using the notation already applied in (6.105), this can be rewritten as

$$\mu_{x,i}^{\ominus}(T, P) - \mu_{c,i}^{\ominus}(T, P) = RT \ln \frac{\rho}{(1 - x_0)M_i + x_0 M_0}, \quad (6.112)$$

which provides the difference of the two standard chemical potentials at the limit of infinite dilution ($x_0 \rightarrow 1$):

$$\mu_{x,i}^{\ominus}(T, P) - \mu_{c,i}^{\ominus}(T, P) = RT \ln \frac{\rho}{M_0}. \quad (6.113)$$

By inserting this in (6.109), upon substitution of the ratio

$$\frac{x_i}{c_i} = \frac{(1 - x_0)M_i + x_0 M_0}{\rho}, \quad (6.114)$$

we get the following result for the ratio of $\gamma_{x,i}$ and $\gamma_{c,i}$:

$$\frac{\gamma_{c,i}}{\gamma_{x,i}} = \frac{\rho}{M_0} \frac{x_i}{c_i} = \frac{M_i}{M_0} x_i + (1 - x_i). \quad (6.115)$$

We can see that the two activity coefficients are in general not equal, except for the case if the molar mass of the solute is identical to the (mean) molar mass of the solvent. If this is not the case, the activity $\gamma_{x,i}$ and $\gamma_{c,i}$ are only approximately equal in dilute solutions where x_i is small enough to be neglected compared to one. We can also state here what has been stated for the activity coefficient on the molality base; at concentrations not negligible compared to one, the activity coefficient $\gamma_{c,i}$ on molarity base is, in general, *not unit*. It is worth noting that the use of molarity is further complicated by the fact that this concentration also depends on temperature, through its density dependence.

From the above comparisons of different reference systems, we can conclude that the use of mole fraction best suits to thermodynamic purposes; it is in accordance with the very definition of ideal mixtures and it does not change either with pressure or with temperature. If – for practical purposes – we use solute concentrations different from mole fraction, molality is to be preferred as it does not depend on density; thus, it is independent of temperature as well.

Note that thermodynamic quantities referenced to infinite dilution – such as the standard chemical potential μ_i^\ominus – depend also on the concentration of components other than component i . Therefore, it is important to know what “solvent composition” the given standard quantity and the derived activity is referenced to. In practical problems, the standard solvent may be rather complex; an example is blood serum, a frequently used solvent in medical practice.

6.3.5 Thermodynamic Properties of a Real Mixture

As already stated when writing (6.84), real mixtures can reasonably be characterized by *excess thermodynamic properties*. Similarly to (6.84), we can write the following for any partial molar property X_i :

$$X_i = X_i^{\text{id}} + X_i^{\text{E}} \quad (6.116)$$

Let us take the Gibbs potential as an example to show the calculation of excess properties in case of a real mixture. The partial molar Gibbs potential is, by definition, the chemical potential, which can be written in the following form:

$$\mu_i = \mu_i^\ominus + RT \ln \gamma_i x_i. \quad (6.117)$$

From this, we can write

$$\mu_i^{\text{id}} = \mu_i^{\ominus} + RT \ln x_i, \quad (6.118)$$

Thus, the excess chemical potential is

$$\mu_i^{\text{E}} = RT \ln \gamma_i. \quad (6.119)$$

(Note that we get the same result in case of other standard concentrations – like c_i or m_i – as well.) From this relation, the excess Gibbs potential as a function of composition is

$$G^{\text{E}} = RT \sum_{i=1}^K n_i \ln \gamma_i, \quad (6.120)$$

while the molar excess Gibbs potential is

$$g^{\text{E}} = RT \sum_{i=1}^K x_i \ln \gamma_i. \quad (6.121)$$

Using common thermodynamic relations, we can easily derive the molar excess entropy:

$$s^{\text{E}} = - \left(\frac{\partial g^{\text{E}}}{\partial T} \right)_{P,n} = -R \sum_{i=1}^K x_i \ln \gamma_i - RT \sum_{i=1}^K x_i \left(\frac{\partial \ln \gamma_i}{\partial T} \right)_{P,n}. \quad (6.122)$$

Similarly, the molar excess volume can be written as follows:

$$v^{\text{E}} = \left(\frac{\partial g^{\text{E}}}{\partial P} \right)_{T,n} = RT \sum_{i=1}^K x_i \left(\frac{\partial \ln \gamma_i}{\partial P} \right)_{T,n}. \quad (6.123)$$

As the molar volume of mixing in ideal mixtures is zero, the above expression also provides the molar volume of mixing for real mixtures.

The molar excess enthalpy can be calculated using the relation

$$h^{\text{E}} = g^{\text{E}} + Ts^{\text{E}} \quad (6.124)$$

as follows:

$$h^{\text{E}} = -RT^2 \sum_{i=1}^K x_i \left(\frac{\partial \ln \gamma_i}{\partial T} \right)_{P,n}. \quad (6.125)$$

This expression also provides the molar enthalpy of mixing for real mixtures, as the molar enthalpy of mixing in ideal mixtures is zero.

Any other excess thermodynamic property can be calculated similarly, applying the corresponding thermodynamic relations to excess properties. These calculations are not really important from a practical point of view. The inverse problem is much more important; if we know excess thermodynamic properties from experiments, activity coefficients can be determined. For example, if the heat capacity of a mixture along with the heat capacities of all the pure components are known from calorimetric measurements, we can calculate the enthalpy and the entropy of mixing. Knowing these two quantities, the Gibbs potential of mixing can also be derived at a given temperature. By comparing this result to the calculated Gibbs potential of mixing of an ideal mixture, the excess Gibbs potential can be calculated. By knowing this quantity as a function of composition, we can also calculate its partial molar value, the excess chemical potential (cf. Sect. 6.1.2), from which the activity coefficient can be obtained using (6.119).

We can get the temperature and pressure dependence of the activity coefficient in a similar way. Based on (6.119), using the Gibbs–Helmholtz equation (A2.23), we can write:

$$\left(\frac{\partial \ln \gamma_i}{\partial T}\right)_{P,n} = \frac{\partial}{\partial T} \left(\frac{\mu_i^E}{RT}\right) = -\frac{H_i^E}{RT^2} \quad (6.126)$$

(Note that – as stated previously – the Gibbs–Helmholtz equation interrelating G and H also holds for the interrelation of the corresponding partial molar properties.) Accordingly, the pressure dependence can be given by the following equation:

$$\left(\frac{\partial \ln \gamma_i}{\partial P}\right)_{T,n} = \frac{\partial}{\partial P} \left(\frac{\mu_i^E}{RT}\right) = \frac{V_i^E}{RT}. \quad (6.127)$$

From the above equations, we can see that to describe the temperature dependence of the activity coefficient, the knowledge of partial molar excess enthalpy is sufficient. Similarly, the partial molar excess volume provides sufficient information to describe its pressure dependence.

If we want to know the properties of a mixture as a function of temperature and pressure, in addition to the composition-dependence, we need to know the temperature and pressure dependence of the standard chemical potential μ_i^\ominus . This can be obtained from (6.11) and (6.12) as

$$\left(\frac{\partial \mu_i^\ominus}{\partial T}\right)_{P,n} = -S_i^\ominus \quad (6.128)$$

and

$$\left(\frac{\partial \mu_i^\ominus}{\partial P}\right)_{T,n} = V_i^\ominus, \quad (6.129)$$

i.e. from the standard partial molar entropy and the standard partial molar volume. In case of the rational and practical activity coefficients, these properties can be obtained from the molar quantities of the corresponding mixtures by calculating the limiting values at $x_i \rightarrow 0$, as described in Sect. 6.1.2. In case of the relative activity coefficient, these are the molar quantities of the pure component i .

6.4 Ideal Solutions and Ideal Dilute Solutions

As it has already been emphasized at the beginning of Sect. 6.3, ideal mixtures do not exist, it is only a formally simple approximation. The applicability of the approximation depends on the extent of the error we allow in the thermodynamic calculations. We have seen that for exact results without approximation, we only need to multiply the mole fraction in the expression of the composition-dependent chemical potential by the activity coefficient f_i , thus keeping the validity of simple formulae valid for ideal mixture. We can accordingly hope that *the formal validity of thermodynamic relations describing ideal mixtures holds if we write relative activity* (referenced to the pure substance) *in place of the mole fraction*. As we shall see in subsequent chapters, this hope is fulfilled in most of the cases.

However, referencing to the pure component is often not reasonable. For example, if we are dealing with dilute solutions only, it is reasonable to restrict thermodynamic description only to the low concentration region we are interested in. Another practical reason is the fact that in the same phase as the solution (liquid or solid), the solute does not exist within the given circumstances, or its solubility is rather low so that only dilute solutions can be made. In these cases, referencing to infinitely dilute solutions – as described in Sect. 3.3.4 – is more convenient. It must be noted, however, that the standard chemical potential is then also different from that of the pure substance.

We can easily elucidate this by simple molecular reasoning. In pure substances, there are only the same molecules; thus, their environment only consists of the same molecules. As long as the number of molecules dissolved in the pure substance (the solvent) is small, the interaction of the molecules does not change much. For this reason, we can consider the solvent – to some approximation – as an ideal component, and its chemical potential can be described by (6.35) using, as standard, the chemical potential of the pure substance. If we do not accept the approximation of ideal mixture, we can substitute the relative activity $a_i = f_i x_i$ in place of the mole fraction. As to the solute molecules in dilute solutions, their molecular surroundings do not consist of the same molecules but mostly of solvent molecules. Diluting the solution, we can arrive sooner or later to a concentration where the solution is dilute enough for that the molecular surrounding (solvent shell) of the solute molecules would not change any more in a detectable manner.

Thermodynamic behavior of this “solvated species” naturally differs from that of the pure species. The standard chemical potential referenced to infinite dilution truly reflects this difference. If it is expressed on mole fraction basis, we can imagine it as the chemical potential of a “pure substance” in the same state as if it were still solvated. (Of course, such substance cannot exist.) If it is expressed on molality or molarity basis, it can be interpreted as the chemical potential of unit molality or molarity – expressed in units of the standard concentration – of a “fully solvated substance”. (Such a solution cannot exist either.)

Thus, standard chemical potentials referenced to different states are necessarily different. The extent of the difference depends on differences between interactions of solvent molecules and that of the solute molecules. If we can calculate the fundamental equation of the mixture based on a molecular model, we can also derive the respective standard chemical potentials. If a suitable model cannot be conceived, standard chemical potentials as well as activity coefficients can be calculated from experimental data.

In summary, we can state that, in dilute solutions, it is reasonable to reference the chemical potential of the *solvent to the pure substance*, while that of the *solute to the limit at infinite dilution* – as described in Sect. 6.3. However, if we accept the approximation that the mixture is ideal, there is no problem with the solute either; the activity coefficient becomes unit and we get back the simple formulae of the ideal mixture.

In analogy to the ideal mixture, it is common practice to consider *ideally dilute solutions*. According to this, the chemical potential of a solute is given by relations where the activity coefficient referenced to infinite dilution is supposed to be unit. However, it is important to emphasize that these solutions are *not ideal* in the sense of the thermodynamic definition. As it is discussed in Sect. 6.3, while the activity coefficient γ_i is unit, the identity $f_i = 1$ is, in general, not valid, apart from some special cases. Therefore, if we deal with the thermodynamic description of ideally dilute solutions, it is crucial to clarify what are the concentrations whose ratio defines the relative activity, and what is the standard chemical potential. If this is clear, we can write the usual simplified expressions containing only concentrations. (Cf. Table 6.2.) We shall also keep in mind that the symbol for concentration written in the simple notation means the ratio of the actual concentration to the standard concentration. Following this simple notation in this book, we shall also drop the *tilde* sign \sim indicating the measured value of the concentration, thus writing only the following simplified expressions in case of ideally dilute solutions:

$$\mu_i = \mu_i^\ominus + RT \ln \gamma_i x_i, \quad (6.130)$$

$$\mu_i = \mu_i^\ominus + RT \ln \gamma_i m_i, \quad (6.131)$$

$$\mu_i = \mu_i^\ominus + RT \ln \gamma_i c_i. \quad (6.132)$$

As we can see, the activity coefficient γ_i as well as the standard chemical potential μ_i^\ominus in these cases is related to unit value of the concentration written in the argument of the logarithm function.

It is also important to know that activity coefficients γ_i on different concentration bases would not be approximately unit within the same error tolerance. Consequently, if a solution is considered ideally dilute due to unit activity coefficient, e.g., on a molality basis, the activity coefficient on a molarity or mole fraction basis is not necessarily unit as well. Thus, the solution cannot be considered generally as ideally dilute in case of other reference concentrations. If we do not allow for approximations but use the exact activity coefficients different from unit, these differences occur naturally.

In following chapters, when discussing actual equilibrium problems, we shall frequently use the approximation of an ideal solution, less frequently the ideally dilute solution approximation. Results obtained this way usually are easy to change so that they become valid for real mixtures as well; we should simply insert the proper activity coefficient as a multiplicative factor of the concentration ratio. This is the reason that we do not always discuss the applicability of thermodynamic relations obtained for ideal mixtures in case of real mixtures.

The notion of ideally dilute solution can be justified with additional arguments. We can calculate the partial molar volume and the partial molar entropy of the solute using (6.43) and (6.44). Though these values are not identical with the corresponding properties of the pure substance prior to mixing (*i.e.* the volume and entropy of mixing are nonzero), but both of them are *independent of concentration*, as long as the approximation of the ideally dilute solution holds on the actual concentration basis.

Problems

1. The densities of two aqueous NaCl solutions were determined at 25°C by using a pycnometer. The density of the 60 g/dm⁻³ concentration solution was found to be 1.0315 g cm⁻³ and that of the 82.5 g/dm³ concentration solution was 1.0463 g cm⁻³. Calculate the partial molar volume of NaCl and that of water in the solution.

Solution: The molar volume of the solution can be expressed in terms of the partial molar volumes and mole fractions of the two components, according to (6.5) and (6.21):

$$v = \sum_{i=1}^2 x_i V_i = x_{\text{H}_2\text{O}} V_{\text{H}_2\text{O}} + x_{\text{NaCl}} V_{\text{NaCl}}$$

Dividing both sides of the equation by v yields:

$$1 = \frac{x_{\text{H}_2\text{O}}}{v} V_{\text{H}_2\text{O}} + \frac{x_{\text{NaCl}}}{v} V_{\text{NaCl}}. \quad (6.133)$$

The mole fraction x_i can be expressed with the help of the mass fraction w_i in the following way:

$$x_i = \frac{n_i}{n} = \frac{m_i/M_i}{m/M} = \frac{m_i}{m} \frac{M}{M_i} = \frac{w_i M}{M_i}.$$

As the density ρ of the solution is the ratio of the molar mass M (of the solution) to the molar volume v (of the solution), we can substitute ρv in place of M . After rearrangement we get:

$$\frac{x_i}{v} = \frac{\rho w_i}{M_i}.$$

By substituting this into (6.133), we get the following relation:

$$1 = \frac{\rho w_{\text{H}_2\text{O}}}{M_{\text{H}_2\text{O}}} V_{\text{H}_2\text{O}} + \frac{\rho w_{\text{NaCl}}}{M_{\text{NaCl}}} V_{\text{NaCl}}$$

We can replace $w_{\text{H}_2\text{O}}$ by $1 - w_{\text{NaCl}}$, and the mass fraction $w_{\text{H}_2\text{O}}$ can be expressed by dividing the mass per volume concentration by the density of the solution; $w_{\text{H}_2\text{O}} = c_{\text{H}_2\text{O}}/\rho$; thus, we get:

$$1 = \frac{\rho \left(1 - \frac{c_{\text{NaCl}}}{\rho}\right)}{M_{\text{H}_2\text{O}}} V_{\text{H}_2\text{O}} + \frac{c_{\text{NaCl}}}{M_{\text{NaCl}}} V_{\text{NaCl}}$$

By rearranging the above equation, we can express ρ as a linear function of the mass per volume concentration of NaCl:

$$\rho = \frac{M_{\text{H}_2\text{O}}}{V_{\text{H}_2\text{O}}} + \left(1 - \frac{V_{\text{NaCl}} M_{\text{H}_2\text{O}}}{V_{\text{H}_2\text{O}} M_{\text{NaCl}}}\right) c_{\text{NaCl}}$$

Substituting experimental data into this equation results in a system of two equations containing two unknown quantities, $V_{\text{H}_2\text{O}}$ and V_{NaCl} . Solving this system of equations yields $V_{\text{H}_2\text{O}} = 18.14 \text{ cm}^3 \text{ mol}^{-1}$ and $V_{\text{NaCl}} = 20.18 \text{ cm}^3 \text{ mol}^{-1}$.

2. The two compartments of a gas container are filled at room temperature with 1 g of helium and 1 g of hydrogen, respectively. We let the two gases mix by opening the valve separating the two compartments. Calculate the change of entropy. (Consider the atomic masses to be 1 and 4 g/mol and both gases as ideal.)

Solution: By taking into account the molar masses, the amounts of the gases are $n_{\text{H}_2} = 0.5 \text{ mol}$ and $n_{\text{He}} = 0.25 \text{ mol}$, summing up to a total amount of 0.75 mol; thus, $x_{\text{H}_2} = 2/3$ and $x_{\text{He}} = 1/3$. Since the two gases are ideal, their mixture is also an ideal mixture, and the entropy of mixing can be calculated using (6.42) as follows:

$$\Delta_{\text{mix}} S = -\frac{3}{4} R \left(\frac{2}{3} \ln \frac{2}{3} + \frac{1}{3} \ln \frac{1}{3} \right) = 0.4774 R$$

3. In a binary thermodynamic system of components A and B, $x_A = 0.1$. In the temperature range not much different from $T = 25^\circ\text{C}$, the relative activity coefficients of the components are given by the empirical formulae

$$\ln \gamma_A = -935.111 x_A T^{-3/2} \quad \text{and} \quad \gamma_A = -0.003.$$

Calculate the molar excess quantities of entropy, enthalpy, and Gibbs potential of the system at 25°C .

Solution: At the temperature of $25^\circ\text{C} = 298.15 \text{ K}$ – based on the formula given – $\ln \gamma_A = -0.0182$; thus, the molar excess Gibbs potential of the system can be calculated using (6.121):

$$g^E = RT(x_A \ln \gamma_A + x_B \ln \gamma_B) = -11.1953 \text{ J mol}^{-1}.$$

To calculate the molar excess enthalpy using (6.125), we need to know the partial derivatives of the logarithms of the activity coefficients with respect to temperature:

$$\left(\frac{\partial \ln \gamma_A}{\partial T}\right)_{P,n} = 140.267 \text{ K}^{1.5} T^{-2.5} = 9.13838 \cdot 10^{-5} \text{ K}^{-1}; \quad \left(\frac{\partial \ln \gamma_B}{\partial T}\right)_{P,n} = 0.$$

Thus, the molar excess enthalpy can be calculated as

$$h^E = -RT^2 \left[x_A \left(\frac{\partial \ln \gamma_A}{\partial T}\right)_{P,n} + x_B \left(\frac{\partial \ln \gamma_B}{\partial T}\right)_{P,n} \right] = -6.7538 \text{ J mol}^{-1}.$$

The molar excess entropy can be calculated by rearranging (6.124):

$$s^E = \frac{h^E - g^E}{T} = -0.0145 \text{ J/(mol K)}$$

Further Reading

- Atkins P, de Paula J (2009) Physical chemistry, 9th edn. Oxford University Press, Oxford
 Balzhiser RE, Samuels MR, Eliassen JD (1972) Chemical engineering thermodynamics – the study of energy, entropy, and equilibrium. Prentice-Hall, Englewood Cliffs, NJ
 Denbigh KG (1981) The principles of chemical equilibrium, 4th edn. Cambridge University Press, Cambridge
 Guggenheim EA (1952) Mixtures. Clarendon, Oxford
 Guggenheim EA (1985) Thermodynamics: an advanced treatment for chemists and physicists, 7th edn. North Holland, Amsterdam

- IUPAC Task Group (1994) Standard quantities in chemical thermodynamics. Fugacities, activities and equilibrium constants for pure and mixed phases (IUPAC Recommendations 1994). *Pure Appl Chem* 66:533–552
- Keszei E, Aszódi A, Balázs L, Borosy A (1990) Extrapolation to infinite dilution using a least-squares estimation. *J Chem Educ* 67:566–569
- Silbey LJ, Alberty RA, Mouni GB (2004) *Physical chemistry*, 4th edn. Wiley, New York

Chapter 7

Phase Equilibria

In previous chapters, we have dealt with *simple systems* specified in Sect. 2.1 as *macroscopically homogeneous*. In this chapter, we remove this constraint and consider thermodynamics of *heterogeneous*¹ systems in which several *phases*² coexist in equilibrium. The homogeneous parts of a heterogeneous system are called phases. Using these terms, we can call simple thermodynamic systems considered earlier as homogeneous phases.

We can further precise the notion of phase; it is the spatially contiguous homogeneous part of a thermodynamic system where intensive variables (in equilibrium) are identical, independently of the spatial location within the phase. This means that intensive variables have usually different values in different phases; thus, they exhibit discontinuity at the phase boundaries. We could treat the phase boundaries as distinct phases whose extension in one direction is as small as the size of a few molecules. However, if the change of the extensive variables (except for the surface of the system) is negligible while changing the size of the phase boundaries, we do not consider them as distinct phases. Accordingly, we only consider *bulk phases* in this chapter; boundary (or surface) phases will be treated in a subsequent chapter. From the thermodynamic point of view, it is of no interest if the same phase is in a single contiguous part or in several fractions. For example, we consider liquid water and ice as two phases even if there are many pieces of ice floating in liquid water.

Within a phase, composition should be identical; thus, immiscible liquids, or solids of different chemical composition also form different phases. Within earthly conditions, it is possible to blend a liquid system consisting of ten vertically separated liquid phases. Gases always mix; thus, there is only one gas phase in a system if it is contained in a contiguous space accessible for the gas molecules

¹The word *heterogeneous* comes from the Greek words *ἕτερος* [heteros] =“other” and *γενος* [genos] = species. It refers to different origin of the parts of an entire system.

²The word *phase* comes from the Greek word *φασίς* [phasis]. Originally, it meant different forms of a planet or star in the course of its change of luminosity (c.f. the phases of the Moon). In thermodynamics, it refers to different forms of the same substance.

without any constraints. Solids usually form distinct phases unless melted, when they could mix into a homogeneous phase in case of miscibility, which then could become a homogeneous solid when freezing.

The number of chemical components is also relevant in the thermodynamic characterization of heterogeneous systems. It is important to emphasize that *component* in this sense means a *chemically independent* component. If, for example, chemical reactions can occur in a system leading to equilibrium, the condition of equilibrium written as constraint equations obviously diminishes the number of degrees of freedom. We take these constraints into account by diminishing the number of species. This has the consequence that the number of components within the same system might change depending on the actual conditions; changes in conditions can disable or enable some reactions. For example, pure water below 2000°C can be considered as one single component. However, at substantially higher temperatures, water dissociates into hydrogen and oxygen. In this case, we should subtract from 3 (H₂O, H₂, and O₂) the number of reactions (H₂O = H₂ + ½ O₂) to get the number of components that becomes 2. Accordingly, if all the three species H₂O, H₂, and O₂ are present in the system, the number of components is 2 above 2000°C; but at room temperature, where neither formation nor dissociation of water occurs in the absence of suitable catalysts, the number of components is 3.

By summing up we can say that we should know the composition of all the phases of a heterogeneous system, and the number of components is considered as the minimum number of chemical species that must be available to form all the species in a chemical equilibrium within the given conditions.

The number of degrees of freedom in a heterogeneous system can readily be calculated from the number of components and phases. In Sect. 2.1, we have concluded from Postulate 1 that a simple system – i.e., one single phase – is completely characterized by its internal energy U , its volume V , and the amounts of the K components n_1, n_2, \dots, n_K . We have expressed this in the form that a homogeneous phase has $K + 2$ *degrees of freedom*, meaning the number of independent variables. If we only need an *intensive characterization* of the system, i.e., the size of the system is of no interest, we can make use of the Gibbs–Duhem equation (2.36):

$$SdT - VdP + \sum_{i=1}^K n_i d\mu_i = 0,$$

which will reduce the number of degrees of freedom by one, resulting in $K + 1$. (The Gibbs–Duhem equation is a constraint for the intensive variables; therefore, they are not independent.) As the entropy S , the volume V and the amounts of components n_i are different in each phase (as well as their molar values s , v , and x_i), in case of an equilibrium of several phases, *a different Gibbs–Duhem equation holds for each phase*. Consequently, each phase reduces the number of degrees of freedom by one. The corresponding formal statement is called the *Gibbs phase rule*:

$$F = K - P + 2. \quad (7.1)$$

As we shall see, this rule has some really useful applications. It is easy to remember; the number of components K always increases, while the number of phases P always decreases the number of degrees of freedom F . The number 2 refers to the two possible interactions of the *simple system* allowed with its surroundings: mechanical and thermal. (If there are further interactions allowed with the surroundings – e.g., magnetic, electric interactions, and elastic deformation – each interaction increases this number usually by one.)

7.1 Stability of Phases

We have stated in the introductory part of Chap. 5, when characterizing equilibria of a single homogeneous phase (a simple system), that entropy is a concave function of the extensive variables, but energy is a convex function of them. In the case of the entropy function, this concavity means that the $(K + 2)$ -dimensional surface representing the function is such that its $(K + 1)$ -dimensional tangent planes lie all *above* the surface. Similarly, tangent planes are situated all *below* the convex energy surface. Other energy-like functions characterizing equilibria within different conditions are also convex functions of their variables given in the respective fundamental equations. This property is reflected in the last column of Table 4.1 summarizing the stability conditions of equilibria.

The significance of stability can be analyzed with the help of the second differential. For a closed system (whose composition does not change), the second differential of the energy function can be given as follows:

$$d^2U = \left(\frac{\partial^2 U}{\partial S^2}\right)_V (dS)^2 + 2 \left(\frac{\partial^2 U}{\partial S \partial V}\right) dS dV + \left(\frac{\partial^2 U}{\partial V^2}\right)_S (dV)^2. \quad (7.2)$$

The condition of convexity requires that the second derivative with respect to S and that with respect to V be positive, and, in addition, d^2U itself should always be positive. This latter condition is fulfilled if the determinant of the symmetrical matrix containing the second derivatives

$$\begin{pmatrix} \frac{\partial^2 U}{\partial S^2} & \frac{\partial^2 U}{\partial S \partial V} \\ \frac{\partial^2 U}{\partial S \partial V} & \frac{\partial^2 U}{\partial V^2} \end{pmatrix}, \quad (7.3)$$

(the *Hessian matrix*) is always positive as well. These conditions imply that

$$\left(\frac{\partial^2 U}{\partial S^2}\right)_V > 0, \quad \left(\frac{\partial^2 U}{\partial V^2}\right)_S > 0 \quad \text{and} \quad \left(\frac{\partial^2 U}{\partial S^2}\right)_V \left(\frac{\partial^2 U}{\partial V^2}\right)_S - \left(\frac{\partial^2 U}{\partial S \partial V}\right)^2 > 0. \quad (7.4)$$

As the first derivative of the energy function $U(S, V)$ with respect to S is the temperature T , we can use the definition of the heat capacity c_V in (4.29) to express the first relation as

$$\left(\frac{\partial T}{\partial S}\right)_V = \frac{T}{n} \frac{1}{c_V} > 0. \quad (7.5)$$

Accordingly, the physical consequence of this stability condition implies that $c_V > 0$, as both T and n are positive. To analyze the second inequality, we make use of the fact that the first derivative of the function $U(S, V)$ with respect to V is $-P$. If we differentiate this again with respect to V to get the second derivative, we may relate it to the *adiabatic compressibility* that can be defined similarly to the isothermal compressibility given by (4.31):

$$\kappa_S \equiv -\frac{1}{V} \left(\frac{\partial V}{\partial P}\right)_S \quad (7.6)$$

From this we get the inequality condition $1/(V\kappa_S) > 0$, which is equivalent to $\kappa_S > 0$, as the volume V is always positive. It is somewhat more tedious to express the third inequality in terms of measurable functions, but we can get the result using the above substitutions as follows:

$$\left(\frac{\partial^2 U}{\partial S^2}\right)_V \left(\frac{\partial^2 U}{\partial V^2}\right)_S - \left(\frac{\partial^2 U}{\partial S \partial V}\right)^2 = \frac{T}{V c_V \kappa_T} > 0. \quad (7.7)$$

By considering the previous condition that $c_V > 0$, this result is equivalent to the condition $\kappa_T > 0$, i.e., the isothermal compressibility should also be positive.

Let us discuss the physical meaning of the two conditions obtained. $c_V > 0$ implies that a stable system should become hotter if heated at constant volume. The conditions $\kappa_S > 0$ and $\kappa_T > 0$ imply that the pressure should increase if we compress the (adiabatic or isothermal) system. These conditions seem to be obvious and are certainly fulfilled, but they are sometimes disobeyed formally, when a particular phase is unstable and typically would form two stable phases. For example, it happens when we apply the van der Waals equation of state in a pressure and temperature region where the compressibility calculated from the equation happens to be negative. (See next section.)

It is easy to show that the above stability conditions cannot be violated. Let us imagine a phase of negative heat capacity in contact with a hotter stable phase (of positive heat capacity). Heat would be transferred from the hotter stable phase into the other, which would become colder and colder due to its negative heat capacity. This would enlarge the difference in temperature between the two phases, which in turn would lead to a higher rate of heat transfer to the phase that becomes colder. A similar unreal consequence follows from a negative compressibility. If such a phase with flexible boundaries is placed in a great container with rigid walls where

the pressure is higher but the compressibility is normal (positive), the negative-compressibility phase would inflate due to the higher external pressure, thus further increasing this pressure, which in turn would lead to further inflation of the negative-compressibility phase.

The energy of a phase as a function of composition cannot be concave either. The “response” of the system is phase separation in this case as well. This case will be treated in a later section after the equilibria of pure phases.

7.2 Phase Equilibria of Pure Substances

Let us begin the thermodynamic treatment of phase equilibria with the simplest heterogeneous systems containing only one single substance. As an example, let us examine the behavior governed by the equation of state of a van der Waals fluid while pressure and temperature change. To do this, we will first derive the van der Waals equation of state in terms of the principle of corresponding states described in Sect. 4.5, using the critical values of the state variables. Curves in Fig. 7.1 show

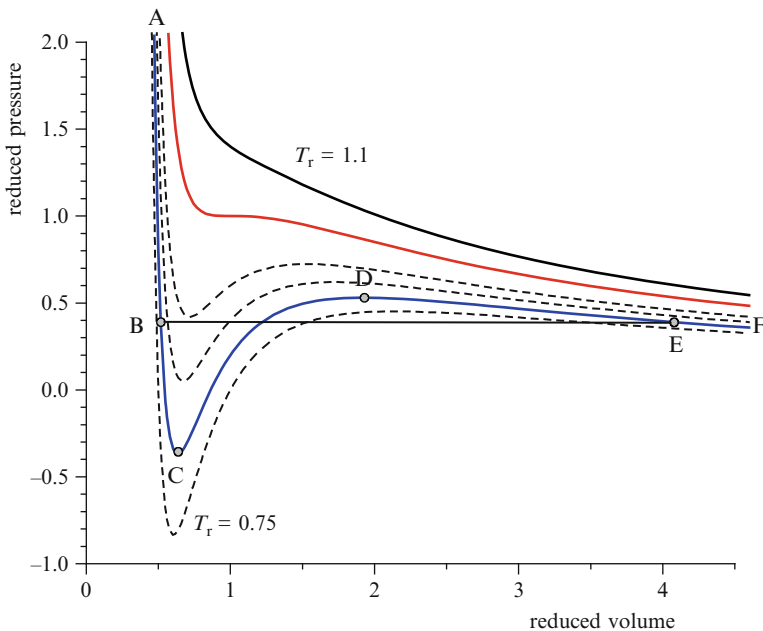

Fig. 7.1 P - V diagram of a van der Waals fluid close to the critical point. Both pressure and temperature are scaled with the critical values, i.e. as reduced pressure P/P_{cr} and reduced volume V/V_{cr} . Isotherms at reduced temperatures $T/T_{cr} = 0.75, 0.8, 0.85, 0.9, 1.0$, and 1.1 are plotted, of which the highest and the lowest are labeled in the diagram. The critical isotherm is the second thick solid line from the top

the behavior of the fluid at different temperatures. The top curve is markedly convex, the second from top has a *horizontal inflexion point*, and neither of the others below is convex as they all exhibit a maximum. The critical P – V curve is the one having the horizontal inflexion. This divides the region of convex curves above and that of the nonconvex ones below, which have a minimum and a maximum as well. Using (2.56), it is easy to find the values of the critical variables as both the first and second derivatives of the $P(V, T)$ function are zero at the horizontal inflexion point:

$$\left(\frac{\partial P}{\partial V}\right)_T = +\frac{2an^2}{V^3} - \frac{nRT_c}{(V - bn)^2} = 0, \quad (7.8)$$

$$\left(\frac{\partial^2 P}{\partial V^2}\right)_T = -\frac{6an^2}{V^4} + \frac{2nRT_c}{(V - bn)^3} = 0. \quad (7.9)$$

Let us solve the two simultaneous equations for the variables T and V to get the critical temperature and volume:

$$T_{\text{cr}} = \frac{8}{27R} \frac{a}{b}, \quad (7.10)$$

$$V_{\text{cr}} = 3bn. \quad (7.11)$$

By substituting these results into the equation of state (2.56), the critical pressure is readily calculated:

$$P_{\text{cr}} = \frac{a}{27b^2}. \quad (7.12)$$

According to Sect. 4.5, we can use the *reduced pressure* P_r , the *reduced temperature* T_r , and the *reduced volume* V_r expressed as

$$P_r = \frac{P}{P_{\text{cr}}}, \quad T_r = \frac{T}{T_{\text{cr}}} \quad \text{and} \quad V_r = \frac{V}{V_{\text{cr}}},$$

to get the *reduced van der Waals equation of state*

$$P_r = \frac{8T_r}{3V_r - 1} - \frac{3}{V_r^2}, \quad (7.13)$$

which provides a fairly good approximation for the description of both the gas phase and the liquid phase in case of many substances. It is this latter property of the

van der Waals equation of state that enables us the thermodynamic analysis of the liquid–vapor equilibrium.

Figure 7.1 shows some typical curves in a P – V diagram calculated from the reduced van der Waals equation of state in the vicinity of the critical point. (A function referring to constant temperature – or its graph – is sometimes called an *isotherm*.³ In this case, it is the curve connecting equilibrium P – V values at constant temperature. For the sake of brevity, we will use this expression during further discussion.) The top curve shows the isotherm at $T_r = 1.1$, which completely obeys the condition of convexity; it is monotonically decreasing at all reduced volumes. This property is shared by all isotherms at $T_r > 1$. The four bottom curves (one solid and three dashed curves) are not convex; they all contain locally concave parts. The transition between these two regions (strictly convex and partly concave) is the curve having a horizontal inflexion point, which is the second from top.

The stability of phases requires the isothermal compressibility κ_T to be positive, which is equivalent to a monotonically decreasing $P(V)$ function. If we check this condition in Fig. 7.1 for the isotherm $T_r = 0.8$, it is only fulfilled along the portion ABC and DEF, but not along CD where the derivative $(dP/dV)_T$ is positive. Consequently, the portion CD is mechanically unstable; thus, there are no possible equilibrium states along this portion of the curve. Though the portions BC and DE locally obey the condition $\kappa_T > 0$ as the derivative $(dP/dV)_T$ is negative along both of them, they also represent unstable states. We can prove this by calculating the chemical potential of the van der Waals fluid as a function of the volume at different temperatures. The chemical potential of a pure substance is its molar Gibbs potential g , as the (extensive) Gibbs potential in this case is simply given by

$$G = ng, \quad (7.14)$$

from which

$$\mu = \left(\frac{\partial G}{\partial n} \right)_{T,P} = \left(\frac{\partial (ng)}{\partial n} \right)_{T,P} = g. \quad (7.15)$$

The chemical potential μ as a function of pressure at constant temperature is given by (6.30):

$$d\mu = VdP.$$

³The word *isotherm* comes from the Greek words *ισος* [isos] = “itself” and *θερμη* [therme] = “heat”, or “hotness”. In thermodynamics, it means “at constant temperature”. One should be careful about “isotherm” as the word could designate a function between *any* variables at constant temperature. In this particular case, both $P(V)$ and $\mu(V)$ can be called an isotherm.

Accordingly,

$$\begin{aligned}\mu(T_r, P_r) &= \mu_0(T_r, P_{r,0}) + \int_{P_{r,0}}^{P_r} V dP \\ &= \mu_0(T_r, V_{r,0}) + \int_{V_{r,0}}^{V_r} V \left(\frac{6}{V^3} - \frac{24T_r}{(3V-1)^2} \right) dV,\end{aligned}\quad (7.16)$$

where the integration variable has been changed from P to V by making use of the equality $\mu(T, P) = \mu(T, V(P))$, differentiating the van der Waals equation of state:

$$dP = \frac{dP}{dV} dV = \left(\frac{6}{V^3} - \frac{24T_r}{(3V-1)^2} \right) dV. \quad (7.17)$$

Let us perform the integration in (7.16):

$$\begin{aligned}\mu - \mu_0(T_r, V_{r,0}) &= \int_{V_{r,0}}^{V_r} V \left(\frac{6}{V^3} - \frac{24T_r}{(3V-1)^2} \right) dV \\ &= -\frac{6}{V_r} + \frac{8T_r}{3(3V_r-1)} - \frac{8T_r}{3} \ln(3V_r-1).\end{aligned}\quad (7.18)$$

The function $\mu - \mu_0$ at different temperatures is displayed in Fig. 7.2. Let us continue the discussion of stability based on this figure as well. Along the locally unstable portion CD, the system is separated into two (stable) phases. One of them is the liquid having smaller molar volume; the other is the vapor having larger molar volume. In equilibrium, both the condition of mechanical equilibrium (the equality of pressures) and that of the chemical equilibrium (the equality of chemical potentials) should hold, which requires that the end points of the horizontal lines in both Figs. 7.1 and 7.2, B and E, should be at the same reduced volumes, respectively. This condition can be written in the following two equations:

$$P_r(T_r, V_B) = P_r(T_r, V_E), \quad (7.19)$$

$$\mu(T_r, V_B) = \mu(T_r, V_E). \quad (7.20)$$

Let us substitute the corresponding variables into (7.13) and (7.18). By solving the simultaneous equations, we get the values of pressure and chemical potential at B and E. This result is displayed in Fig. 7.3, where the reduced volumes at the points B and E are identical with those shown in Figs. 7.1 and 7.2.

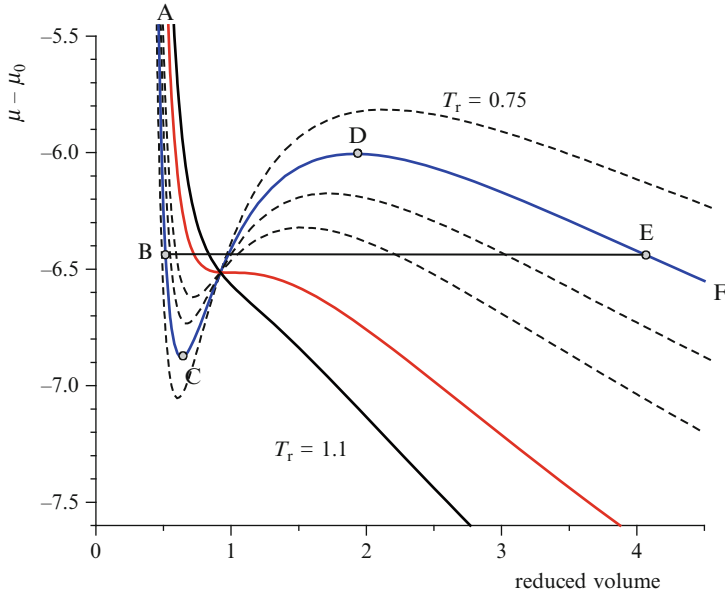

Fig. 7.2 The chemical potential difference $\mu - \mu_0$ of a van der Waals fluid as a function of the reduced volume in the vicinity of the critical point. Isotherms at reduced temperatures $T/T_{cr} = 0.75, 0.8, 0.85, 0.9, 1.0$ and 1.1 are plotted, of which the highest and the lowest are labeled in the diagram. The critical isotherm at low volumes is the second thick solid line from the top, at high volumes it is the second from the bottom

The reduced volume values at points B and E can also be determined solely from the chemical potential condition, which is the same at the two points; $\mu_B = \mu_E$. According to (7.18), we can write for their difference

$$\mu_E - \mu_B = \int_{V_{r,B}}^{V_{r,E}} V \left(\frac{dP}{dV} \right) dV = 0, \tag{7.21}$$

which means that the integral of the isotherm in Fig. 7.1 between B and E is zero. In geometrical terms, the area between the curve BCDE and the straight line BE is such that the area above and that below the line are equal. This property of the isotherm was first described by Maxwell, so it is usually called the *Maxwell construction*. This construction and the solution of equations (7.19) – (7.20) yields the same results for the reduced volumes at B and E, as they are based on the same relations.

Figure 7.3 is usually called the *liquid–vapor phase diagram* (of a pure substance). Isotherms below the critical point in this diagram are such that the reduced volume of the liquid is never greater than the one which fulfills both the condition of mechanical and that of the chemical equilibrium. If the equation of state of the van

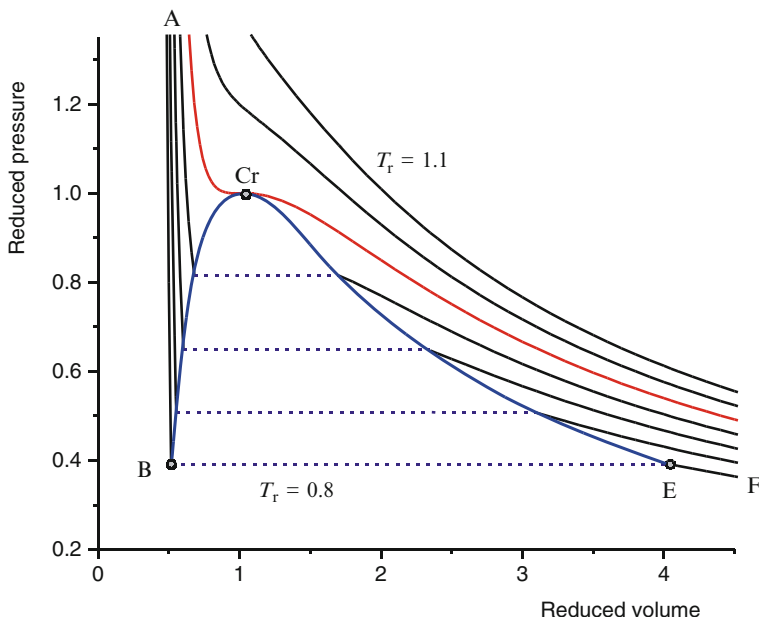

Fig. 7.3 Equilibrium pressure of the van der Waals fluid as a function of the reduced volume in the vicinity of the critical point. Isotherms at reduced temperatures $T/T_{cr} = 0.75, 0.8, 0.85, 0.9, 1.0,$ and 1.1 are plotted, of which the highest and the lowest are labeled in the diagram. The stable phases of a two-phase system are connected by the bell-shaped curve. Along the left portion of this curve, there is only liquid; along the right portion, there is only vapor. Below the curve, there are *no phases*; if two phases are present in equilibrium in the system, their respective states are interconnected by the *horizontal dotted lines*

der Waals fluid would predict a greater volume, the increase in volume will be achieved by the evaporation of part of the fluid, producing vapor whose state will be the one according to the least possible volume which is stable at the actual temperature. For example, in the case of the isotherm at $T_r = 0.8$, the substance is liquid all along the portion AB, but if its volume is further increased at B, part of the liquid will evaporate resulting vapor in a state according to E. As long as there is liquid left in the system, both pressure and chemical potential remain constant while the volume increases due to evaporation. If there is no more liquid left, further increase in volume can happen along the portion EF of the isotherm. There is no phase at any volume between B and E. If the mean volume of a two-phase system lies within this region, one part of it is always liquid (at point B) and the other part is vapor (at point E).

From the above considerations we can conclude that stable phases should not only obey the conditions $c_V > 0$ and $\kappa_T > 0$ – the *local stability conditions* – but also the *global stability conditions*, which means that the phases in equilibrium with each other should also satisfy (7.19) and (7.20). According to this, states along the portions BC and DE in Fig. 7.2 of the isotherm $T_r = 0.8$ are locally stable but not

globally stable. The physical consequence is interesting; if a pure liquid is expanded, and the volume becomes greater than $V_{r,B}$ corresponding to point B, in the absence of vapor and air, the metastable liquid can survive – even until point C where it becomes mechanically unstable and vapor will necessarily be formed. Within these circumstances, the evaporation cannot happen at the surface of the liquid, but bubbles should form for the vapor to appear. To form bubbles, energy should be concentrated at the site of the bubble to be formed, which needs large *fluctuations* in local energy. Until the occurrence of a large enough fluctuation, there will be no bubble formed, and the metastable (superheated) liquid phase survives. In a similar way, the vapor phase whose state lies along the isotherm between D and E is metastable; its molar volume is lower than that of the stable vapor at E. However, until droplets would be formed, the vapor cannot condense to liquid. Formation of the droplet also needs a relatively large fluctuation in energy; thus, the metastable (supercooled or supersaturated) vapor can also survive.

The instability of both the liquid and the vapor can be efficiently eliminated by the presence of electrically charged particles, which largely facilitate the formation of droplets as well as bubbles. (The early detection of ionizing particles was also based on this phenomenon in a bubble chamber or cloud chamber.) A similar effect is the condensation of vapor on tiny soot particles which leads to the formation of *contrails* (short for condensation trail), easily seen behind jet planes, especially in the morning or evening hours when the water vapor in the air is supercooled due to low air temperatures.

7.2.1 Phase Diagrams of Pure Substances

A phase diagram in general is a graph showing the existence region of phases in a heterogeneous system in equilibrium, as a function of the state variables. The actual form of this graph varies according to the function plotted and its variables. In case of pure substances, the most general phase diagram is the tridimensional plot of the function $P(V, T)$. In this diagram, we can find the already discussed liquid and vapor phases along with their transition region, but also different solid phases and the solid–liquid, solid–vapor, and eventual solid–solid transitions. As tridimensional surfaces are complicated to show, a more common type of the phase diagram is their two-dimensional projection, which is easier to show on a piece of paper (or on a screen). In a narrower sense, these two-dimensional representations are called phase diagrams.

One possible type of a $P(V, T)$ state surface or P – V – T diagram is shown in Fig. 7.4. We can recognize on this surface the phase-free transition region of the liquid–vapor equilibrium with the liquid phase on the left and the vapor phase on the right edge. The critical point is labeled as Cr. At higher pressures and temperatures than the critical point, there is no phase separation and that is the reason for designating the phase in this region as *gas*. The name *vapor* is used only for states lying below the critical pressure and temperature, i.e., they can coexist

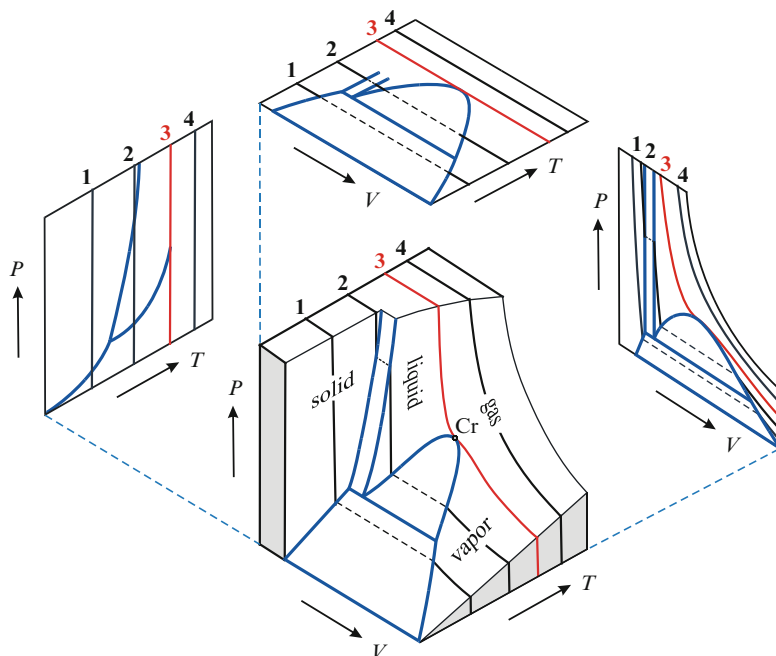

Fig. 7.4 P - V - T diagram of a pure substance and its projections (phase diagrams) in case of a substance whose solid phase has a smaller molar volume than its liquid phase. Isotherms (curves at constant temperature) are marked by the numbers 1, 2, 3, and 4, on both the 3D surface and the 2D projections. There exist no phases between the solid lines (on the 3D surface as well as in the 2D projections) if the states of coexistent phases are interconnected by *dashed lines* (of constant temperature and pressure)

in equilibrium with a liquid at the same pressure and temperature. It is also readily seen from the figure that the solid phase is only stable at the lowest volumes, in equilibrium with the vapor at low temperatures and the liquid at higher temperatures.

There is a limiting line between the liquid–vapor and the solid–vapor transition area. The temperature and pressure of this line between the two no-phase areas are constant; thus, the three phases can only coexist at this particular temperature and pressure. The locus of the coexistence on the $P(V, T)$ surface and in the $T(V)$ and $P(V)$ projections is called the *triple line*, while its projection in the $P(T)$ plane is the *triple point*. It is easy to show that three phases of a single component can only coexist at fixed temperature and pressure. Applying the Gibbs phase rule (7.1), the number of degrees of freedom if there is one component and three phases is $F = K - P + 2 = 0$. This means that there is no possibility to determine any one of the intensive variables arbitrarily if all the three phases are present in the system; this can only happen at fixed temperature and pressure determined by the thermodynamic properties (the fundamental equation) of the substance. This temperature and pressure of the triple point can be calculated by solving the two simultaneous

equations for the equality of the chemical potentials of the three phases in equilibrium.

It is also straightforward to show that the projection of the $P(V, T)$ surface into the $P(T)$ plane consists only of simple (one-dimensional) curves, not of two-dimensional areas – contrarily to the case of the two other projections. In the $P(T)$ plane, each curve is a locus of points corresponding to the coexistence of two phases in equilibrium. According to the phase rule, these one-component two-phase systems have $1 - 2 + 2 = 1$ degree of freedom, which means that if we fix a given temperature T , all other (intensive) thermodynamic properties are fixed, the pressure P among them. In other words, in the graph showing the coexistence of two phases, there is always one possible pressure at a given temperature. These three coexistence curves – as explained in the previous paragraph – should meet at a single point; the triple point having zero degrees of freedom.

An interesting consequence of the simple curves in the P - T phase diagram is that the coexistence curve of the liquid and vapor phase *ends* at the critical point, as there is no phase separation beyond this point in the P - V - T diagram; thus, there are not two phases present but one. The number of degrees of freedom is also 2 in this area; thus, both temperature and pressure are free to determine here, and the equilibrium state of the single phase follows these conditions. According to this, it is possible to change the state of the liquid into vapor without phase transition (i.e., without having both phases present in the system). To do so, changes of state should be performed bypassing the no-phase area while arriving into the single-phase region above the critical point and then changing the state again to bypass the no-phase area while reducing temperature and pressure to arrive into the range of vapor. The projected trajectory in the $P(T)$ plane goes around the critical point.

Both on the $P(V, T)$ surface and the projections, we can observe that the stability region of the liquid phase has not only an upper limit, but also a lower one; below the pressure of the triple line, there is no liquid phase but an equilibrium of solid and vapor. Accordingly, below the temperature of the triple point in the $P(T)$ plane, there is no liquid phase either. This can also be concluded from the behavior of the chemical potential as a function of pressure and temperature. At a given pressure and temperature, it is always the phase having the lowest chemical potential which is stable. (As it is stated in Sect. 3.3, the substance from the higher chemical potential region would flow to the lower chemical potential region.) According to (7.15), the chemical potential of a pure substance is its molar Gibbs potential, whose total differential can be written, following (4.22) as

$$d\mu^\alpha = -s^\alpha dT + v^\alpha dP, \quad (7.22)$$

where s^α is the molar entropy and v^α is the molar volume of the phase α . These two quantities can be given as the partial derivatives of the function $\mu(T, P)$:

$$-s^\alpha = \left(\frac{\partial \mu^\alpha}{\partial T} \right)_P \quad \text{and} \quad v^\alpha = \left(\frac{\partial \mu^\alpha}{\partial P} \right)_T. \quad (7.23)$$

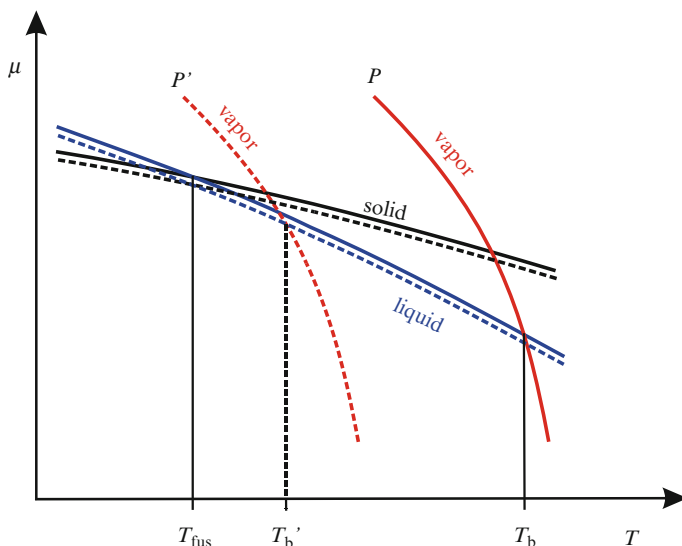

Fig. 7.5 Chemical potential of different phases of a pure substance as a function of temperature. Solid curves show the chemical potentials at a given pressure P and dashed curves at a lower pressure P' . When changing the pressure from P to P' , the boiling point change from T_b to T_b' is much greater than the melting point change from T_{fus} to T'_{fus} . This latter is so small that it cannot be seen in the diagram

Accordingly, the slope of the chemical potential curve in a μ - T diagram is the molar entropy of the actual phase. As we can see in Fig. 7.5, the relation between the slopes of the chemical potential curves of different phases reflects the relation between the respective molar entropies:

$$s_v \gg s_l > s_s, \quad (7.24)$$

i.e., the entropy of the vapor (far from the critical point) is much greater than that of the liquid, which is somewhat greater than that of the solid.

Figure 7.5 shows sections of the function $\mu(T, P)$ at constant pressure. The change of these functions $\mu(T)$ with pressure depends on the molar volume of the phases. As the molar volume of the vapor (far from the critical point) is much greater than that of the liquid or solid, the $\mu(T)$ curve of the vapor is shifted a lot compared to the $\mu(T)$ curve of the liquid or solid, if the pressure is reduced – as it can be seen in the figure. Further reduction of the pressure leads to regions where the chemical potential of the liquid is always higher than that of the vapor or the solid. At these pressures the solid would not melt but evaporate directly, which is called *sublimation*. In between the two regions, there exists a pressure at a certain temperature where the chemical potentials of the solid, the liquid, and the vapor coincide. This is the triple point where all the three phases can coexist.

An interesting and relatively rare group of substances has a somewhat different phase diagram than the one in Fig. 7.4. They exhibit the feature that their solid

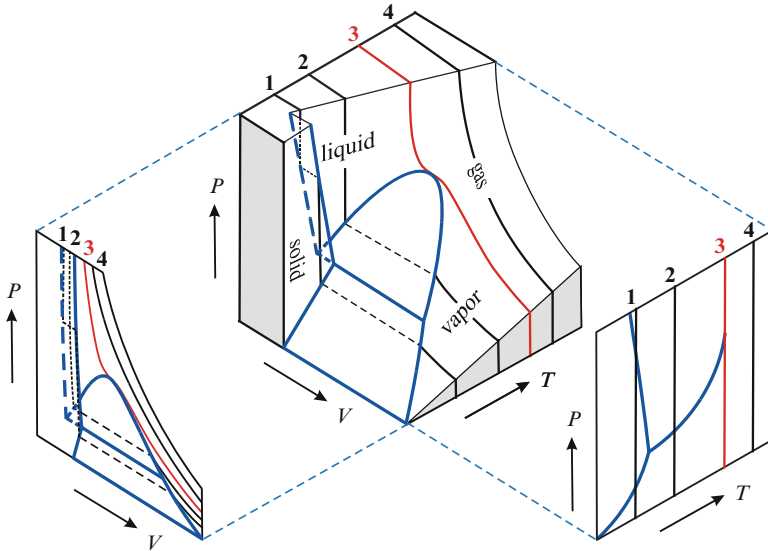

Fig. 7.6 P - V - T diagram of a pure substance and its projections (phase diagrams) in case of a substance whose solid phase has a larger molar volume than its liquid phase. The notation is the same as in Fig. 7.4

phase in equilibrium with the liquid phase has a *larger* molar volume than the liquid phase; thus, they *dilate* at freezing, instead of contracting. A common example for this behavior is water, which breaks bottles and pipelines when freezing. In Fig. 7.6, in addition to the greater molar volume of the solid compared to the liquid, we can see another difference with respect to Fig. 7.4. As it can be seen from the projection $P(T)$, the melting point (equilibrium temperature between the solid and liquid phase) is reduced with increasing pressure. This property can be interpreted the following way. If the molar volume decreases while melting, higher pressure facilitates melting; thus, less energy is needed to melt the solid. (This behavior is also related to the stability of phases. Its general statement is called the *Le Châtelier–Braun principle*. A more detailed explanation of this principle is described in Chapter 8, in relation with chemical reactions.) The reason for sliding on the surface of ice is also this; by exercising pressure on ice, the melting point decreases and part of the ice will melt. Water formed this way lubricates the surface, largely decreasing friction.

7.2.2 Calculation of the Quantity of Coexisting phases: the Lever Rule

Phase diagrams can also be used to calculate the proportions between two phases in equilibrium. For this purpose, the independent variable of the plotted function

Fig. 7.7 Notation used to calculate vapor quality in a P - V diagram

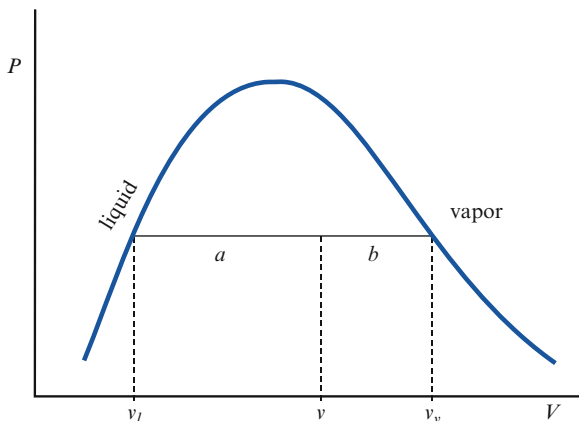

should be an extensive variable (or its molar value), as for example in a P - V , T - V , T - S , or T - H diagram. Let us consider the P - V diagram of Fig. 7.3, replotted in Fig. 7.7 for this purpose. The average molar volume of the system containing vapor and liquid is denoted by v . The molar volume of the vapor is v_v and that of the liquid is v_l in equilibrium at the pressure corresponding to the horizontal line. Along this line, the distance between the molar volume of the liquid and the average molar volume is a , between the average molar volume and that of the vapor is b .

The volume V of the liquid-vapor system can be given in terms of the amounts of the liquid n_l and that of the vapor n_v :

$$V = n_l v_l + n_v v_v = (n_l + n_v) v. \quad (7.25)$$

Let us substitute $v - a$ for v_l and $v + b$ for v_v :

$$n_l(v - a) + n_v(v + b) = (n_l + n_v) v. \quad (7.26)$$

Let us perform the multiplications:

$$n_l v - n_l a + n_v v + n_v b = n_l v + n_v v. \quad (7.27)$$

By eliminating terms present at both sides of the equation, we get

$$n_v b = n_l a. \quad (7.28)$$

This relation is traditionally called the *lever rule*.⁴ Using this rule, we can calculate the relative vapor content of the system:

⁴The name of the rule comes from the equation of balance of a first class lever where the condition of equilibrium is that the left weight multiplied by its distance from the fulcrum equals the right weight multiplied by its distance from the fulcrum.

$$\frac{n_v}{n_v + n_l} = \frac{n_v}{n_v + n_v(b/a)} = \frac{a}{a + b}. \quad (7.29)$$

To get this result, n_l is expressed from the lever rule and then both numerator and denominator are multiplied by a/n_v . The relative vapor content of a liquid–vapor system is called *vapor quality* which is related in steam engines and turbines to the ability of vapor to do useful work.

The ratio of the amounts of two phases can be calculated similarly in other phase diagrams having an extensive variable (or its molar value) at the horizontal, and an intensive one at the vertical axis, for example, in a T – V , T – S , or T – H diagram.

7.2.3 Calculation of Equilibrium Temperature and Pressure; the Clausius–Clapeyron Equation

If we are not interested in the amount of the coexisting phases, the projection of the $P(V, T)$ state surface into the P – T plane provides enough information for an intensive characterization of phase equilibria. Curves indicating the locus of points where two phases coexist in this diagram are easy to calculate from thermodynamic relations. To do these calculations, consider the phase diagram in Fig. 7.8.

The curves indicating the coexistence of the same pair of phases are continuous, without breakpoints. At a given temperature, there is only one point where the two phases can coexist. These curves can be constructed from the temperature and pressure dependence of the chemical potential. Two phases (say, α and β) are in equilibrium if their chemical potentials are equal:

$$\mu^\alpha = \mu^\beta. \quad (7.30)$$

This condition should be fulfilled at any point of the coexistence curves. Whenever the pressure changes, the temperature should also change in a way that

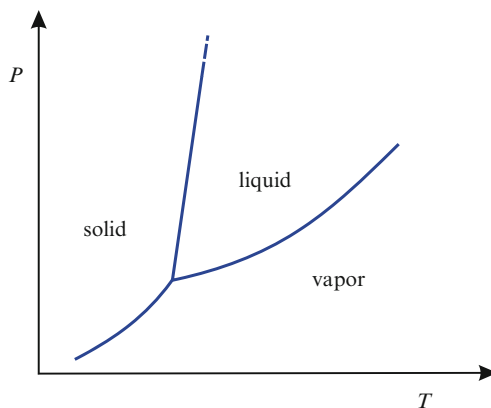

Fig. 7.8 P – T phase diagram of a pure substance whose molar volume increases at melting

the chemical potentials of the two phases changed by $d\mu^\alpha$ and $d\mu^\beta$ should be equal again:

$$\mu^\alpha + d\mu^\alpha = \mu^\beta + d\mu^\beta. \quad (7.31)$$

The validity of the two above conditions require that

$$d\mu^\alpha = d\mu^\beta. \quad (7.32)$$

The total differentials of the chemical potentials as a function of the temperature and pressure can be given (cf. (7.22)) as follows:

$$-s^\alpha dT + v^\alpha dP = -s^\beta dT + v^\beta dP. \quad (7.33)$$

By rearranging this equation, we get

$$(v^\beta - v^\alpha) dP = (s^\beta - s^\alpha) dT. \quad (7.34)$$

The difference $\Delta_{\alpha}^{\beta}v = v^\beta - v^\alpha$ is the change in molar volume and $\Delta_{\alpha}^{\beta}s = s^\beta - s^\alpha$ is the change in molar entropy upon phase transition $\alpha \rightarrow \beta$. By substituting these symbols, the condition for coexistence becomes

$$\frac{dP}{dT} = \frac{\Delta_{\alpha}^{\beta}s}{\Delta_{\alpha}^{\beta}v}. \quad (7.35)$$

Solution of the above differential equation yields the function describing the coexistence curve. However, we can rewrite the equation making use that the chemical potential of the pure substance – the molar Gibbs potential – can be written as $\mu = h - Ts$. Let us rewrite the equality of the chemical potentials of the two phases as

$$h^\alpha - Ts^\alpha = h^\beta - Ts^\beta. \quad (7.36)$$

By rearranging, we can express the molar transition entropy $\Delta_{\alpha}^{\beta}s = s^\beta - s^\alpha$ with the molar transition enthalpy:

$$s^\beta - s^\alpha = \frac{h^\beta - h^\alpha}{T}. \quad (7.37)$$

Using the notation $\Delta_{\alpha}^{\beta}h = h^\beta - h^\alpha$, the differential equation for the coexistence curve is the following:

$$\frac{dP}{dT} = \frac{\Delta_{\alpha}^{\beta}h}{T \Delta_{\alpha}^{\beta}v}. \quad (7.38)$$

This is called the *Clapeyron equation*.⁵ (It is worth noting that if we would have written the equilibrium condition in terms of the entropy-representation intensive variable μ/T instead of μ , we would directly obtain the Clapeyron equation.) This equation describes the coexistence of any two phases. Accordingly,

$$\frac{dP}{dT} = \frac{\Delta_{\text{fus}}h}{T\Delta_{\text{fus}}v} \quad (7.39)$$

is the equation of the *melting point curve* characterizing solid–liquid equilibrium.

$$\frac{dP}{dT} = \frac{\Delta_{\text{b}}h}{T\Delta_{\text{b}}v} \quad (7.40)$$

is the equation of the *boiling point curve* characterizing liquid–vapor equilibrium, and

$$\frac{dP}{dT} = \frac{\Delta_{\text{sub}}h}{T\Delta_{\text{sub}}v} \quad (7.41)$$

is the equation of the *sublimation point curve* characterizing solid–vapor equilibrium.

If one of the two phases is vapor, the change in molar volume upon phase transition is easy to calculate with a fairly good approximation. Far from the critical point, the molar volume of the condensed phases is negligible compared to that of the vapor; thus, the sublimation volume $\Delta_{\text{sub}}v$ as well as the boiling (vaporization) volume $\Delta_{\text{b}}v$ can be substituted by the volume of the vapor. (The volume of 1 mol solid or liquid water at room temperature is approximately 0.018 dm^3 , while that of the vapor is about 24 dm^3 . Neglecting 0.018 dm^3 leads only to an error not greater than 0.08%.) Let us also suppose that the vapor behaves as an ideal gas and substitute $v = RT/P$ for its molar volume. By rewriting the Clapeyron equation by applying these approximations, we get

$$\frac{1}{P} \frac{dP}{dT} = \frac{\Delta_{\text{b}}h}{RT^2}, \quad (7.42)$$

which can be rewritten substituting $d \ln P$ for $(1/P) dP$ as

$$\frac{d \ln P}{dT} = \frac{\Delta_{\text{b}}h}{RT^2}. \quad (7.43)$$

⁵Benoît Paul Émile Clapeyron (1799–1864) was a French engineer and physicist. He was responsible for the construction of the first French railway lines, but he also dealt with thermodynamics. He discovered Sadi Carnot's pioneering work two years after Carnot's death and reformulated it in simpler mathematical terms. He elaborated the theory of reversible processes and further developed the results of Clausius concerning entropy. This latter work led to the equation named after him and the one named after Clausius and him.

The above equation is called the *Clausius–Clapeyron equation*.⁶ A similar equation can also be derived for sublimation as well, writing the sublimation enthalpy $\Delta_{\text{sub}}h$ in place of $\Delta_{\text{b}}h$.

By integrating this equation, we can calculate the equilibrium vapor pressure at any temperature T_2 if we know it at another temperature T_1 . The integration is easy to perform supposing that the sublimation or vaporization enthalpy does not change with temperature in the range from T_1 to T_2 :

$$\int_{P_1}^{P_2} d \ln P = \frac{\Delta_{\text{vap}}h}{R} \int_{T_1}^{T_2} \frac{1}{T^2} dT \quad (7.44)$$

The result of the integration can be given in a form ready for vapor pressure calculations:

$$P_2 = P_1 e^{-\frac{\Delta_{\text{vap}}h}{R} \left(\frac{1}{T_2} - \frac{1}{T_1} \right)}. \quad (7.45)$$

The equilibrium between two condensed phases is somewhat more complicated. Let us consider the Clapeyron equation for the solid–liquid equilibrium:

$$\frac{dP}{dT} = \frac{\Delta_{\text{fus}}h}{T\Delta_{\text{fus}}v}.$$

Fusion is an endothermic process; thus, the numerator on the right-hand side is always positive. The sign of the denominator is also positive for the majority of substances; for those which dilate upon melting. As the molar volume change is usually little with respect to the enthalpy change during phase transition, the slope of the solid–liquid coexistence curve (dP/dT) is a large positive value. For substances such as water – which shrink upon melting – the slope is negative, but it has also a large absolute value. (To raise the melting point of water ice by 1°C, an increase of 140 kbar in pressure is needed.) As a consequence, the solid–liquid coexistence curve in a P – T phase diagram is always very steep and its orientation is determined by the sign of the fusion volume $\Delta_{\text{fus}}v$. Similar conclusions can be drawn for the case of a solid–solid equilibrium.

7.2.4 First-Order and Second-Order Phase Transitions

As explained in Sect. 7.2.3, differences in the partial derivatives of the $\mu(T, P)$ function determine the shape of the coexistence curve in the phase diagram. These derivatives can be related to other thermodynamic quantities:

⁶Rudolf Julius Emmanuel Clausius (1822–1888) was a German physicist. He had a determining role in the development of thermodynamics. He introduced the notion of entropy and formulated the Second Law of thermodynamics in terms of it.

$$\left(\frac{\partial\mu}{\partial T}\right)_P = -s, \quad (7.46)$$

$$\left(\frac{\partial\mu}{\partial P}\right)_T = v, \quad (7.47)$$

$$\left(\frac{\partial^2\mu}{\partial T^2}\right)_P = -\left(\frac{\partial s}{\partial T}\right)_P = -\frac{c_P}{T}, \quad (7.48)$$

$$\left(\frac{\partial^2\mu}{\partial P^2}\right)_T = \left(\frac{\partial v}{\partial P}\right)_T = -v\kappa_T. \quad (7.49)$$

In the case of phase transitions discussed so far, plots of chemical potential *vs.* temperature for different phases have different slopes at their intersection – as it can be seen in Fig. 7.5. This means that their derivatives are different in different phases. Molar entropy, for example, is always smaller in the phase stable at lower equilibrium temperature than that in the other phase, which is stable at higher equilibrium temperature. Molar volume is mostly also smaller in the phase stable at lower temperatures – though there are exceptions, as we have discussed before. As a consequence, the functions $s(T, P)$ and $v(T, P)$ should have a discontinuity at the equilibrium pressure and temperature.

The behavior of the second derivatives is even more interesting; they are *infinite* at the coexistence of two phases. Consider, for example the transition ice \rightarrow water. If a two-phase equilibrium system is heated, its *temperature would not change*, as the absorbed heat is used to melt some ice. As a consequence, the derivative $(dQ/dT)_P$ becomes infinite due to the zero increment in the denominator. The other way around; if we cool the ice–water system, its temperature would not change either, only part of the water will freeze. (This happens also in spring; while snow is melting during the day, air does not warm up. Similarly, it does not cool during the night until the melted water would freeze; thus, air temperature tends to be close to 0°C.) For this reason, enthalpy changes upon phase transitions are also called *latent heat*.⁷

In a similar manner, isothermal compressibility also becomes infinite at coexistence. In case of a liquid–vapor equilibrium, the pressure would not change upon compression of the system until vapor exists that can condense, thus keeping the equilibrium pressure constant. In this case, the derivative $(dv/dP)_T$ becomes infinite.

The behavior of the chemical potential function and its derivatives as a function of temperature is graphically shown in the upper diagrams of Fig. 7.9. The dashed vertical line with an upward arrow symbolizes infinite heat capacity. It is worth

⁷Until the late nineteenth century, the *substance of heat* was considered as a “subtle fluid” called *caloric*. Caloric was “filled” in a body upon heating, and “withdrawn” upon cooling. (This is still conserved in expressions like “heat capacity”). The theory interpreted that heat can be extracted at constant temperature from a system under phase transition as a “hidden” form of heat, which was termed *latent* after the Latin word of the same meaning *latens*.

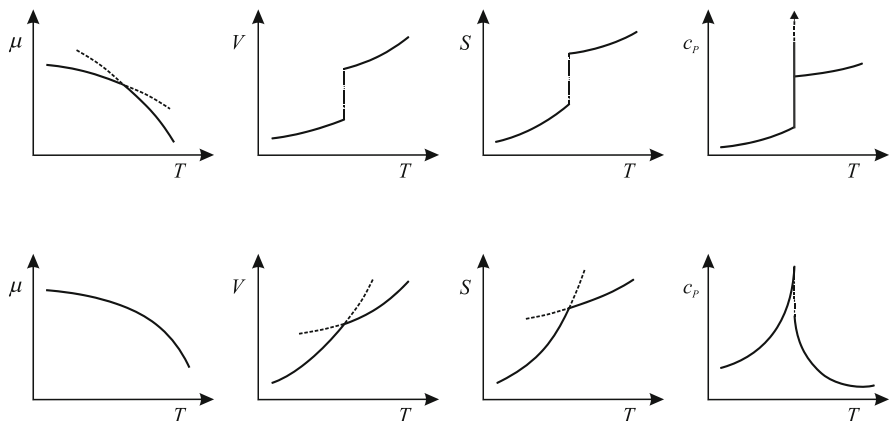

Fig. 7.9 Plots of the chemical potential μ , the volume V , the entropy S , and the heat capacity c_p as a function of temperature in the vicinity of a phase transition. Upper diagrams: first-order phase transition; lower diagrams: second-order phase transition

noting that molar entropy is always increased upon transition to the phase which is stable above the transition temperature, while molar volume and heat capacity could increase but also decrease, depending on the nature of the substance.

Phase transitions discussed above all exhibit a latent heat of transition and are called *first-order* phase transitions. There exists another class discovered in the mid-twentieth century, which is called *second-order* or *continuous* phase transitions. They also exhibit well-defined transition temperature and pressure, but their chemical potential as a function of temperature is continuous and differentiable (does not have a breakpoint) at the transition temperature. However, the first derivatives of the chemical potential function – molar volume and molar entropy – do have a breakpoint similar to that of the chemical potential in case of first-order transitions. Consequently, the second derivatives – compressibility and heat capacity – exhibit discontinuity at the transition temperature. This is the origin of the name “second order”.

By observing Fig. 7.9, in case of a first-order transition (upper diagrams), prior to the transition we cannot see any sign in the heat capacity that a transition is about to occur. The same is true for the compressibility as a function of pressure (not shown). The behavior of the first derivatives – molar volume and molar entropy – does not “forecast” the transition either. In contrast, the behavior of c_p in case of a second-order phase transition “forecasts” the transition; the function turns into a huge increase. After the transition, it falls back steeply (but still continuously) to a “normal” slow change with increasing temperature. Researchers who discovered this kind of transition have seen the shape of the Greek letter λ (lambda) in the plot of the c_p function. That is the reason they are also called *lambda transition*.

Macroscopic (classical) thermodynamics is unable to provide satisfactory explanations for second-order phase transitions. Though a relation similar to the Clapeyron equation can be formulated for the *second* derivatives of the chemical potential functions, the phase rule cannot be applied for the equilibrium of these transitions, and the behavior of the second derivatives (the λ shape) cannot be explained. Second-order phase transitions can only be interpreted at a molecular level, taking into account *fluctuations* around the local equilibrium state. Typical second-order phase transitions are the transition of solid β -brass or that of the solid salts of complex ions such as NH_4^+ , NO_3^- , SO_4^{2-} , and PO_4^{3-} . Upon these transitions, it is not the crystal structure that would change but either the internal symmetry of the crystals or the mode of molecular movement of the complex ions.

The cubic β -brass crystal contains an equal number of Cu and Zn atoms. The two kinds of atoms are arranged as two interpenetrated cubic lattices where each Cu atom has eight Zn neighbors, and vice versa. At low temperatures, this minimum energy structure is stable, despite of its low entropy. With increasing temperature, large enough small-scale fluctuations enable some Cu and Zn neighbors to swap locations. But swapping locations needs higher energy than simple vibration of the atoms; thus, the heat capacity also increases with increasing temperature. As more and more atoms change location, further changes become easier from an energetic point of view, because the minimum energy structure is continuously destroyed. This “positive feedback” further increases the tendency of structure changes, also increasing the energy consumption and thus the heat capacity as well. The transition temperature (742 K) is in the state when the atoms’ locations in the entire crystal become completely random. Heat capacity is restored to a “normal” low level at this temperature, as further heating only increases the vibrational energy of the atoms at the lattice points.

In case of some complex ions, the crystal structure at low temperatures does not enable rotation around all the rotational axes. As temperature rises, fluctuations lead to the onset of these “forbidden” rotations. At the λ -transition, all rotations can freely happen. Other types of λ -transitions are magnetic transitions of some metal crystals and conductor–semiconductor transitions. The liquid–vapor transition is also a second-order transition at the critical temperature.

7.3 Liquid–Vapor Equilibrium of Ideal Binary Mixtures

The condition of liquid–vapor equilibrium in a multicomponent system if all the components of the liquid evaporate in a detectable amount is the equality of chemical potentials in the two phases for each of the components:

$$\mu_{i,l} = \mu_{i,g}. \quad (7.50)$$

According to (6.36), the chemical potential can be given using the standard potential μ_i^* and the mole fraction x_i . This latter can be replaced by the quotient of

the partial pressure p_i and the total pressure p^\ominus ; thus, we can write the equilibrium condition as

$$\mu_{i,l}^* + RT \ln x_i = \mu_{i,g}^* + RT \ln \frac{p_i}{p^\ominus}. \quad (7.51)$$

For the pure component ($x_i = 1$) at the same temperature and pressure, we can write

$$\mu_{i,l}^* = \mu_{i,g}^* + RT \ln \frac{p_i^*}{p^\ominus}. \quad (7.52)$$

Subtracting the two equations results in:

$$RT \ln x_i = RT \ln \frac{p_i}{p_i^*}. \quad (7.53)$$

Obviously, the arguments of the two logarithms should be equal, which leads to the following equation valid for ideal mixtures:

$$p_i = x_i p_i^*. \quad (7.54)$$

This equation is the formal statement of *Raoult's Law*.⁸ Using this equation, we can calculate the vapor pressure of ideal mixtures.

Let us calculate the vapor pressure P_{tot} of ideal binary (i.e., containing two components) liquid mixtures. This can be given as the sum of the partial pressures of the two components:

$$P_{\text{tot}} = x_1 p_1^* + x_2 p_2^*. \quad (7.55)$$

As x_1 and x_2 are not independent, we can substitute $(1 - x_1)$ in place of x_2 :

$$P_{\text{tot}} = x_1 p_1^* + (1 - x_1) p_2^* = p_2^* + x_1 (p_1^* - p_2^*) \quad (7.56)$$

According to this result, the total vapor pressure of the binary liquid is a *linear* function of the concentration x_1 , as it can be seen in Fig. 7.10.

The equilibrium vapor pressure can also be given as a function of the vapor composition. Mole fractions of the components y_1 and y_2 can be given with the help of the respective partial pressures:

$$y_1 = \frac{p_1}{P_{\text{tot}}} \quad y_2 = \frac{p_2}{P_{\text{tot}}}. \quad (7.57)$$

⁸François-Marie Raoult (1830–1901) was a French chemist. He was the first to conduct experiments on the freezing point and vapor pressure depression of dilute solutions, which is the reason for naming the law of vapor pressure depression as Raoult's Law.

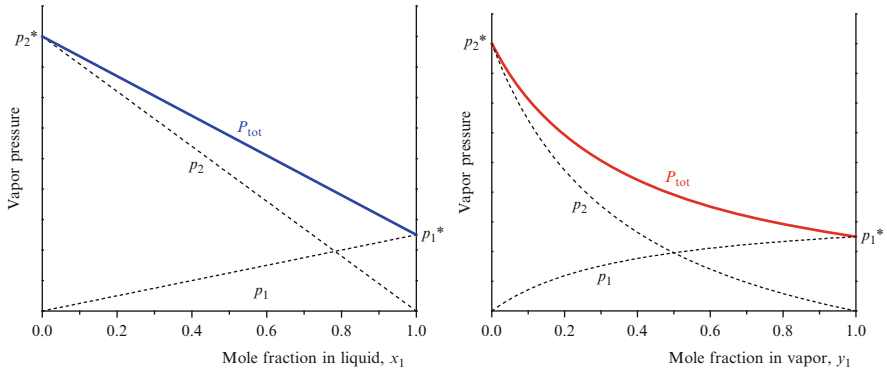

Fig. 7.10 Vapor pressure of an ideal binary mixture as a function of the liquid and the vapor composition, respectively, at the same temperature

Based on Raoult’s Law, the mole fraction x_1 in the liquid phase can be written as

$$x_1 = \frac{y_1 P_{\text{tot}}}{p_1^*}, \tag{7.58}$$

and this can be substituted into the expression (7.56) for the total pressure:

$$P_{\text{tot}} = p_2^* + \frac{y_1 P_{\text{tot}}}{p_1^*} p_1^* - y_1 P_{\text{tot}} \frac{p_2^*}{p_1^*}. \tag{7.59}$$

By rearranging, we can factor out P_{tot} :

$$P_{\text{tot}} \left(1 - y_1 + y_1 \frac{p_2^*}{p_1^*} \right) = p_2^*. \tag{7.60}$$

Further rearrangement leads to an expression for the total pressure as a function of the mole fraction y_1 :

$$P_{\text{tot}} = \frac{p_1^* p_2^*}{p_1^* + y_1 (p_2^* - p_1^*)}. \tag{7.61}$$

This expression has the form

$$P_{\text{tot}} = \frac{\text{constant}_1}{\text{constant}_2 + \text{constant}_3 y_1}, \tag{7.62}$$

which is a transformed hyperbola – as can be seen in Fig. 7.10.

In Fig. 7.11, the same curves are shown, with the regions of stability of the phases labeled. It is easy to interpret the two diagrams from a thermodynamic point

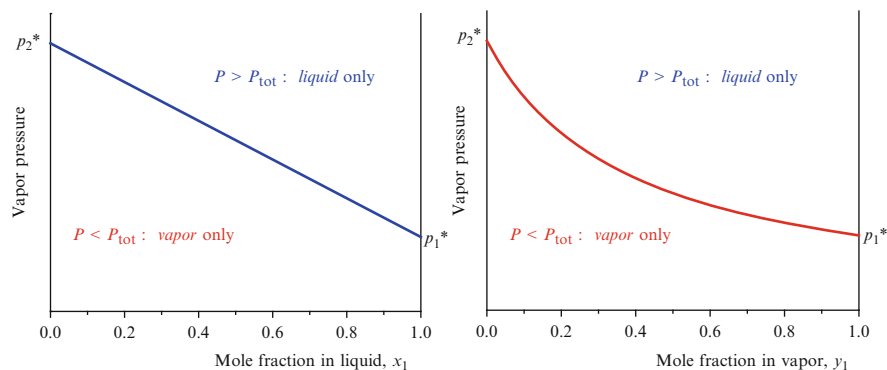

Fig. 7.11 Stability regions of the liquid and vapor phases of an ideal binary mixture as a function of the liquid and the vapor composition, respectively, at the same temperature

of view. According to the phase rule, if there are two phases present in a two-component system, the number of degrees of freedom is $F = K + 2 - P = 2$. Thus, if temperature (which is the same in both diagrams) and composition are fixed, the system has a unique pressure – the *equilibrium vapor pressure* or *saturated vapor pressure*. This vapor pressure is determined by the equations (7.56) and (7.61), according to Raoult's Law. If the pressure is lower, the liquid is unstable; it completely evaporates. If the pressure is higher, the vapor is unstable; it completely condensates. Thus, the vapor pressure curve exactly shows the boundary between the regions of stability of the liquid and the vapor phases.

It is sensible to combine the two curves of Fig. 7.11 in a single diagram. The resulting diagram in Fig. 7.12 is called the *liquid–vapor phase diagram*. Of course, there is only one concentration scale on the horizontal axis; this denotes liquid composition in case of the upper straight line, but vapor composition in case of the lower hyperbolic curve. The upper line is still the *vapor pressure curve* (of the liquid mixture), but above this line – as discussed before – only the liquid phase is stable; therefore, it is also called the *liquid curve*. The lower curve shows the pressure (of the vapor mixture) where the vapor condenses (droplets of liquid are formed); therefore, it is called the *dew point curve*. However, as below this curve only the vapor phase is stable, it is also called the *vapor curve*.

The combination of the two diagrams and their concentration scales requires a slightly different interpretation concerning the stability range of the phases as was the case for the two distinct diagrams. If the liquid having a composition labeled x_l evaporates, the vapor formed should have the composition labeled x_v , as this is in equilibrium with the liquid. (The two phases in equilibrium should have the same pressure.) According to this, there is no phase in between the two points L and V, along the horizontal solid line interconnecting these points. This is the case at any other pressure as well; thus, the area between the two curves is a *no-phase region*. If we would not take into account that the system contains two phases, but monitor

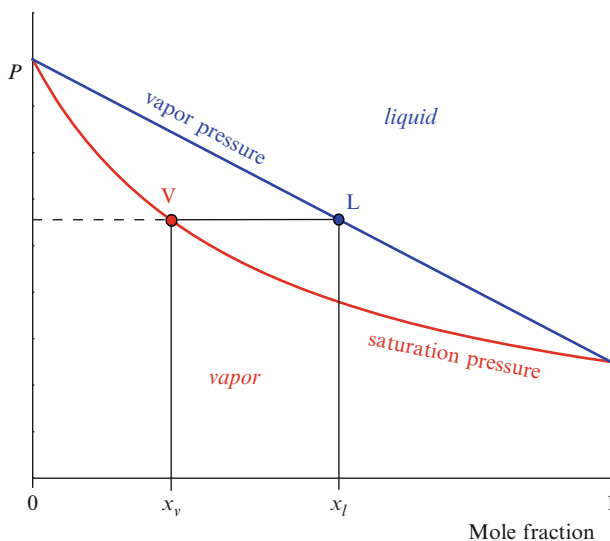

Fig. 7.12 The pressure–composition liquid–vapor phase diagram of an ideal binary mixture

only the *overall composition* of the two-phase system, this should fall between x_l and x_v . This is why the no-phase region is often called as *two-phase region*. However, this may be misleading, as *there is no stable phase between the two curves*; in the two-phase system, the vapor composition is on the vapor curve and the liquid composition is on the liquid curve.

The two points L and V indicating the composition of the phases in equilibrium at a given pressure are called *nodes* hence, the line interconnecting them (the *tie line* – solid line in the figure) is also called *conode*. In this phase diagram, the conode coincides with an *isobar*, i.e., a horizontal line indicating constant pressure.

Another useful liquid–vapor phase diagram is the one where the equilibrium temperature is shown as a function of the composition, at constant pressure. This also consists of two curves: the *boiling point curve* as a function of the liquid composition, and the *dew point curve* as a function of the vapor composition, and it is called the *temperature–composition phase diagram* or *T–x phase diagram*. The one corresponding to Fig. 7.12 is shown in Fig. 7.13. A major difference is that here the upper region (at higher temperatures) is the stability range of the vapor phase, while the liquid phase is stable below the dew point curve (at lower temperatures). Accordingly, the upper curve is the vapor curve and the lower one the liquid curve.

At the temperature indicated by the horizontal line, the liquid of composition x_l could only form vapor whose composition is x_v , as this is in equilibrium with the liquid. (The two phases in equilibrium should have the same temperature.) Consequently, along the tie line interconnecting L and V, there cannot be any stable phase; thus, the area between the two curves is a no-phase region in this diagram as well. Note that the tie line coincides with an *isotherm*, i.e., a horizontal line indicating constant temperature.

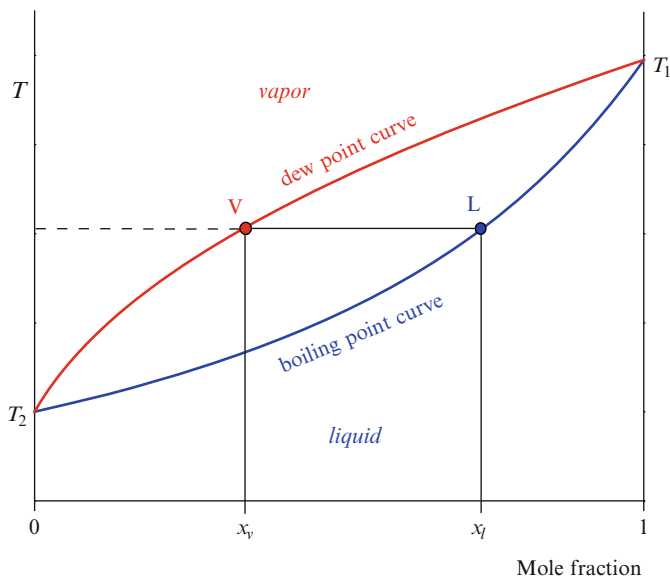

Fig. 7.13 Temperature–composition (or T – x) liquid–vapor phase diagram of an ideal binary mixture

This phase diagram can be constructed the following way. It is a section of a tridimensional surface x – T – P where the total pressure P_{tot} is constant and can be given using (7.56) as the sum of the partial pressures of the two components. To calculate this, we need the equilibrium vapor pressures of the components, p_1^* and p_2^* , between the boiling points of the two components, T_2 and T_1 , which can be calculated using the integral form (7.45) of the Clausius–Clapeyron equation:

$$p_i^*(T) = p_i^*(T_2) e^{-\frac{\Delta_{\text{vap}}h_i}{R} \left(\frac{1}{T} - \frac{1}{T_2} \right)}. \quad (7.63)$$

Vapor pressures obtained this way can be substituted into (7.56), and the solution of the resulting equation yields the composition x_1 at a given temperature T corresponding to the total pressure P_{tot} :

$$x_1 = \frac{P_{\text{tot}} - p_2^*(T)}{p_1^*(T) - p_2^*(T)}. \quad (7.64)$$

Once the liquid composition x_1 is known, the vapor composition y_1 is readily calculated using (7.57):

$$y_1 = \frac{x_1 p_1^*}{P_{\text{tot}}}. \quad (7.65)$$

In the T - x phase diagram, the liquid curve (i.e., the boiling point curve) is no more a straight line but a convex curve, which is a consequence of the exponential nature of the Clausius–Clapeyron equation.

As discussed in Sect. 7.2.2, the ratio of the amounts of the two phases can be calculated based on phase diagrams having an extensive variable (or its molar value) at the horizontal, and an intensive one at the vertical axis. The T - x diagram in Fig. 7.13 has mole fraction at the horizontal axis which is the molar value of the extensive amount of substance; i.e., the lever rule can be applied. The notation is shown in Fig. 7.14; along the horizontal line indicating equilibrium temperature, the overall composition is x and that of the two phases x_l and x_v , respectively. The distance between x_v and x is denoted by a and that between x_l and x by b . The amount n of the liquid–vapor system can be given in terms of the amounts of the liquid n_l and that of the vapor n_v :

$$n = n_l x_l + n_v x_v = (n_l + n_v) x. \quad (7.66)$$

Let us substitute $x + b$ for x_l and $x - a$ for x_v :

$$n_l(x + b) + n_v(x - a) = (n_l + n_v) x. \quad (7.67)$$

By performing the multiplications and combining terms we get the “lever rule”

$$n_v a = n_l b, \quad (7.68)$$

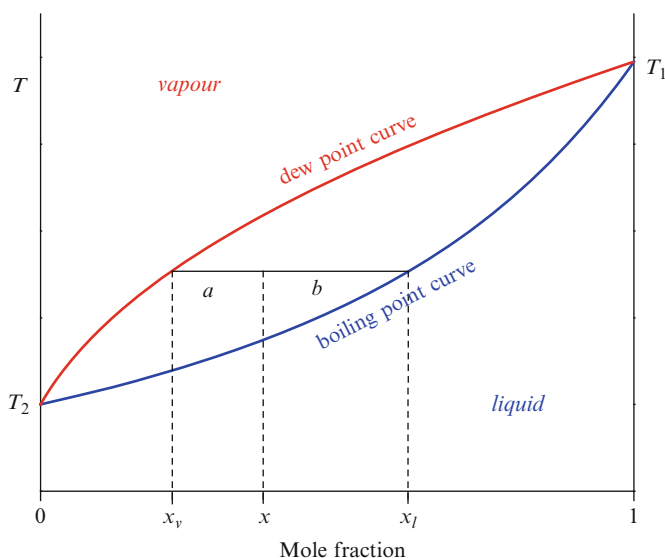

Fig. 7.14 Notations for the calculation of the amount of liquid and vapor in a binary liquid–vapor phase diagram using the “lever rule”. The overall mole fraction of component 1 is x in the heterogeneous system containing both phases; it is x_l in the liquid and x_v in the vapor phase

which readily yields the ratio of vapor to liquid as

$$\frac{n_v}{n_l} = \frac{b}{a}. \quad (7.69)$$

7.4 Liquid–Vapor Equilibrium of Real Binary Mixtures

We cannot expect existing liquid mixtures to follow the ideal behavior described in the previous section. Though there exist some liquid mixtures with components whose molecules are closely related to each other, for example the benzene–toluene mixture, which follow the ideal behavior to a good approximation, the majority of real mixtures exhibit a large variety of deviation from this behavior. As molecular interactions depend on composition, the partial pressure of the components does not follow Raoult’s law, and deviations also depend on composition. From the thermodynamics of mixtures, we already know that we can characterize these deviations by writing the nonideal chemical potential $\mu_{i,l}^* + RT \ln \gamma_i x_i$ into (7.51)–(7.54) leading to Raoult’s law in a real mixture. This way, we get the nonideal equivalent of Raoult’s law:

$$p_i = \gamma_i x_i p_i^*. \quad (7.70)$$

Let us consider the example of the ethanol–water mixture shown in Fig. 7.15. As it can be seen in the diagram, both components have higher partial pressures

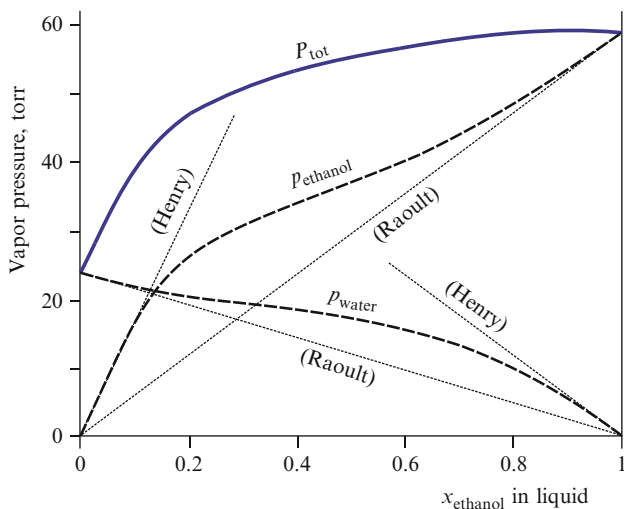

Fig. 7.15 Vapor pressure vs. composition diagram of the binary mixture ethanol–water. Thin dotted lines show partial pressures according to Raoult’s law and, at low concentrations of the components, partial pressures according to Henry’s law

than could be calculated from Raoult's law. This is usually called a *positive deviation* from ideality, or from Raoult's law. (Similarly, a *negative deviation* means lower vapor pressures than predicted by Raoult's law. This is the case in acetone–chloroform or nitric acid–water mixtures.) Despite of deviations, at high concentrations (close to unit mole fraction) the partial pressures of concentrated ethanol or water are quite close to the one predicted by Raoult's law. Here we recall that the activity with respect to the pure substance reflects a behavior close to Raoult's law – as mentioned in connection with (6.86).

At low concentrations (close to zero mole fractions), the partial pressures strongly deviate from that predicted by Raoult's law. However, in a certain range of low concentrations, they are linear functions of the composition. This follows from the nature of molecular interactions as described in Sect. 6.4 concerning dilute solutions. By diluting the binary mixture, a composition is sooner or later achieved where the solution is dilute enough that the structure of the solute molecules surrounded by the solvent molecules and their interaction will not change significantly with further dilution. The thermodynamic behavior of this “solvated component” is of course different than that of the nearly pure substance, which is reflected in the partial pressures obeying *Henry's law*.⁹ This is why Henry's law is recalled in connection of the activity with respect to the infinitely dilute solution.

The liquid–vapor phase diagram of real binary mixtures can strongly deviate from the ideal behavior if molecular interactions are largely dependent on composition. In case of a positive deviation from Raoult's law, when molecules are less strongly bound together in the mixture than in the pure liquids, it also occurs that the vapor pressure of the mixture is superior to that of the more volatile pure liquid. In this case, the mixture evaporates easier than the more volatile pure component. Contrarily, if molecular interactions are stronger in the mixture than in the pure liquids, the vapor pressure of the mixture can be inferior to that of the less volatile pure liquid in a certain composition range. By depending on the molecular interactions, liquid–vapor phase diagrams of real mixtures are distorted with respect to the “cigar shape” of ideal mixtures seen in Fig. 7.13. If there exist mixtures whose vapor pressure is inferior or superior to that of one of the pure components, neither the boiling point curve nor the dew point curve is monotonous, but both exhibit extrema where the composition of liquid and vapor coincide. This is also the case for the ethanol–water mixture. Its T – x phase diagram can be seen in Fig. 7.16 – though in a somewhat schematic way, as the temperature scale for part of the curve is magnified to see the detailed shape. It is worth noting that the composition of the minimum boiling point mixture coincides with that of the small vapor pressure maximum in Fig. 7.15.

⁹William Henry (1775–1836) was an English chemist. In a paper in 1803, he describes his experiments concerning the solubility of gases in water. According to these results, the partial pressure of the dissolved gas is proportional to its concentration: $p_i = x_i K_i$, which is called *Henry's law*. However, the proportionality factor K_i is not the pressure of the pure component but a markedly different value characteristic of the gas.

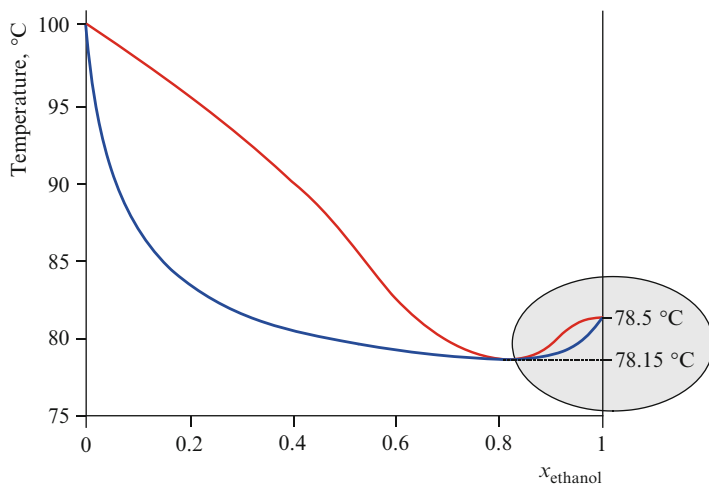

Fig. 7.16 Composition–temperature phase diagram of the ethanol–water mixture. The temperature scale is expanded in the concentration range above the azeotrope concentration, indicated by the gray area, to better see details of the equilibrium curves

Mixtures which exhibit these extrema are called *azeotropes* (or *azeotropic mixtures*), and the composition at the extremum is called the *azeotropic composition*.¹⁰ Using our thermodynamic knowledge, we can easily predict the shape of the liquid and the vapor curve of an azeotrope in the phase diagram. Let us write the Gibbs–Duhem equation for both phases in equilibrium:

$$S^v dT - V^v dP + n_1^v d\mu_1 + n_2^v d\mu_2 = 0, \quad (7.71)$$

$$S^l dT - V^l dP + n_1^l d\mu_1 + n_2^l d\mu_2 = 0. \quad (7.72)$$

These equations rely on the fact that the temperature T , the pressure P and the chemical potentials of the components μ_1 and μ_2 should be the same in equilibrium. Let us rewrite the equations for 1 mol of the phases, i.e., divide both equations by the amount of the respective phases. As a result, we can write molar entropy and molar volume, along with mole fractions instead of the amounts of components. In a binary mixture, it is enough to write one of the two mole fractions, which we will denote by x , and the other component having a concentration of $1 - x$:

$$s^v dT - v^v dP + (1 - x^v) d\mu_1 + x^v d\mu_2 = 0, \quad (7.73)$$

$$s^l dT - v^l dP + (1 - x^l) d\mu_1 + x^l d\mu_2 = 0. \quad (7.74)$$

¹⁰The word *azeotrope* has Greek origin. It is the adjective formed from the verb ζεω = boil and the noun τροπή = change (or turn), with the prefix α- denoting negation. The compound word α-ζεω-τροπικός [a-zeo-tropikos] means “boils without change”.

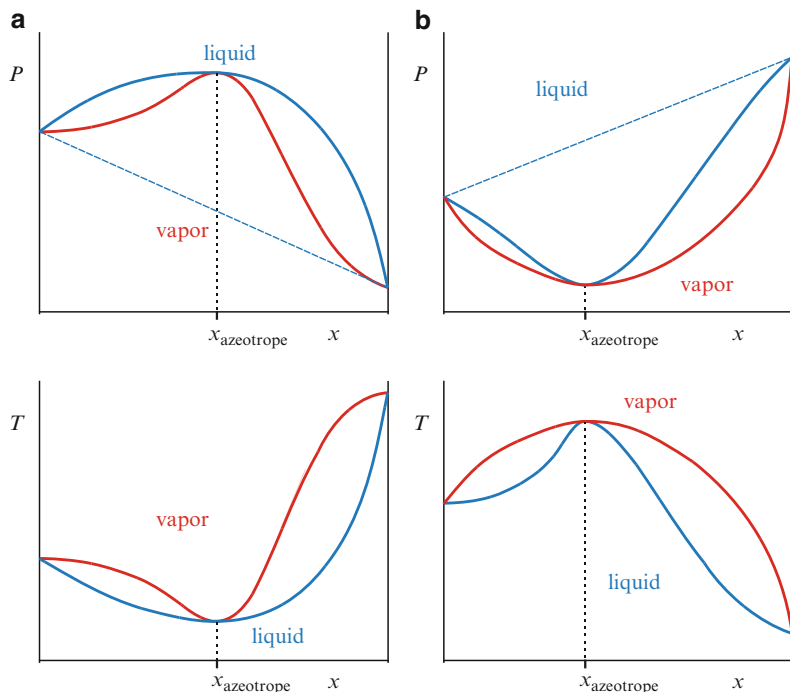

Fig. 7.17 Schematic phase diagrams of azeotropes. (a) Minimum-boiling azeotrope where the vapor pressure of the mixture is superior to that of the more volatile pure component. (b) Maximum-boiling azeotrope where the vapor pressure of the mixture is inferior to that of the less volatile pure component. In the P - x diagrams, the dashed lines indicate the vapor pressure of an ideal mixture (according to Raoult's law)

By subtracting the two equations, we get:

$$(s^v - s^l)dT - (v^v - v^l)dP - (x^v - x^l)(d\mu_1 - d\mu_2) = 0. \quad (7.75)$$

At a fixed temperature ($dT = 0$), the first term is zero, and the pressure and the chemical potentials can be treated as *univariate* functions of the composition variable x – keeping in mind that the two-phase two-component binary system at fixed temperature has only one remaining degree of freedom. By making use of this and applying the chain rule, we can write:

$$-(v^v - v^l) \frac{dP}{dx} dx = (x^v - x^l) \left(\frac{d\mu_1}{dx} - \frac{d\mu_2}{dx} \right) dx \quad (\text{at constant } T). \quad (7.76)$$

The composition does not change during evaporation at the azeotropic composition; thus, we can write $x^v - x^l = 0$, which renders the right side of the equation zero. On the left side, neither $v^v - v^l$, nor dx is zero, which reduces the condition to

$$\frac{dP}{dx} = 0 \quad (\text{at constant } T). \quad (7.77)$$

By considering constant pressure ($dP = 0$) and rewriting (7.75), we get similar results at the azeotropic composition:

$$(s^v - s^l) \frac{dT}{dx} dx = (x^v - x^l) \left(\frac{d\mu_1}{dx} - \frac{d\mu_2}{dx} \right) dx \quad (\text{at constant } P), \quad (7.78)$$

$$\frac{dT}{dx} = 0 \quad (\text{at constant } P). \quad (7.79)$$

In summary, both equilibrium curves (liquid and vapor) exhibit an extremum in the T - x , as well as in the P - x diagram at the azeotropic composition, which can be either a minimum or a maximum. As the composition is the same in the vapor and the liquid, the two extrema coincide. This behavior is illustrated by the phase diagrams in Fig. 7.17, where the constant temperature in the P - x diagram is the boiling point of the azeotrope, so the composition $x_{\text{azeotrope}}$ is the same in both diagrams of the same type. (As we would expect, the composition of the azeotrope depends on the pressure and temperature.)

7.5 Solid–Liquid Equilibrium of Ideal Binary Mixtures

In solids, the conditions of miscibility are more restricted than in liquids, due to the possible differences in the crystal structure of different substances that can hinder or even prevent the formation of *mixed crystals* (or *solid solutions*). Existing nearly ideal solid mixtures illustrate this principal; typical examples are, e.g., gold–platinum or gold–silver mixtures, where the crystal structure of the constituents is very close to each other. The T - x phase diagram of such mixtures is shown in Fig. 7.18.

The calculation of the equilibrium curves is based in this case also on the equality of chemical potentials in the two phases. According to the notation in the diagram, component 1 has the higher melting point (T_1). The condition of equilibrium for this component at a temperature T , such that $T_1 > T > T_2$, is:

$$\mu_{1,s}^*(T) + RT \ln x_{1,s} = \mu_{1,l}^*(T) + RT \ln x_{1,l}. \quad (7.80)$$

By rearranging, we get:

$$\mu_{1,s}^*(T) - \mu_{1,l}^*(T) = RT \ln \frac{x_{1,l}}{x_{1,s}}. \quad (7.81)$$

A similar equation holds for the other component as well. If we know the temperature dependence of the chemical potentials $\mu_i^*(T)$, we can solve the

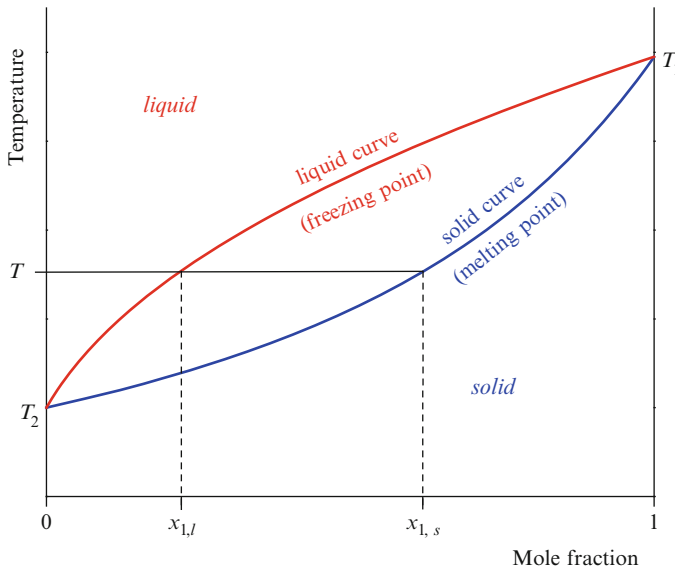

Fig. 7.18 Temperature–composition solid–liquid phase diagram of an ideal binary mixture

simultaneous equations and get the compositions of the two phases in equilibrium. From the above equation, we can see that at lower temperatures than T_1 (the melting point of component 1) where the solid mixture melts, the solid phase of pure component 1 is stable. This means that $\mu_{1,s}^*(T) < \mu_{1,l}^*(T)$, which in turn requires $\ln(x_{1,l}/x_{1,s}) < 0$. Accordingly, even without solving the equations we can conclude that the relation $x_{1,l} < x_{1,s}$ holds. The actual shape depends on the chemical potential functions $\mu_i^*(T)$.

7.6 Equilibrium of Partially Miscible Binary Mixtures

As pointed out at the end of Sect. 7.1, if the energy of a phase as a function of composition is not convex, the “response” of the system is phase separation. At constant temperature and pressure, the Gibbs potential $G(T, P, \mathbf{n})$ is minimal in equilibrium. If we are interested in an intensive characterization of the system, it is the minimum of the *molar Gibbs potential* $g(T, P, \mathbf{x})$ which can be used as a criterion for equilibrium. This should be convex as a function of the molar extensive variables x_i .

According to (6.39), the molar Gibbs potential of an ideal mixture can be written as

$$g = \sum_{i=1}^K x_i (\mu_i^* + RT \ln x_i). \quad (7.82)$$

Let us write the sum for an ideal binary mixture:

$$g = x_1\mu_1^* + (1 - x_1)\mu_2^* + RT[x_1 \ln x_1 + (1 - x_1) \ln(1 - x_1)]. \quad (7.83)$$

By rearranging, we get:

$$g = \mu_2^* + x_1(\mu_1^* - \mu_2^*) + RT[x_1 \ln x_1 + (1 - x_1) \ln(1 - x_1)]. \quad (7.84)$$

It is easy to see from this equation that the molar Gibbs potential of the mixture as a function of the composition varies between the pure components' chemical potential $\mu_2^*(T)$ and $\mu_1^*(T)$ – which are the molar Gibbs potentials of the pure components. Due to the last term, g is always convex, as both x_1 and $(1 - x_1)$ are less than unity. The actual shape of the curve depends on the ratio of $\mu_1^*(T)$ and $\mu_2^*(T)$ to the energy RT ; as the sum $\mu_1^*(T) + \mu_2^*(T)$ becomes smaller with respect to RT , the shape will be more curved, and the minimum becomes deeper and closer to the location of the minimum of the term in square brackets which is at $x_1 = 0.5$.

It is worth noting that if the two components are immiscible, the molar Gibbs potential of the “mechanical dispersion” (or completely separated phases) is the linear combination of the chemical potentials of the two pure components, according to the first two terms of (7.83) and the straight line in Fig. 7.19. This also illustrates why substances mix; the molar Gibbs potential of the mixture is lower at all compositions than the sum of the molar Gibbs potentials of the components; thus, mixing leads to a decrease of the Gibbs potential.

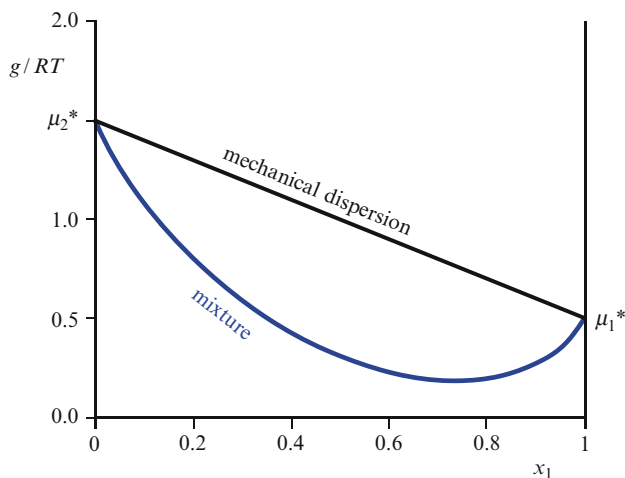

Fig. 7.19 Molar Gibbs potential of an ideal binary mixture as a function of composition. The vertical (energy) scale is in RT units. The molar Gibbs potentials of the components are $\mu_1^*(T) = 0.5RT$ and $\mu_2^*(T) = 1.5RT$. The line marked “mechanical dispersion” shows the molar Gibbs potential of immiscible components

Chemical potentials of the components in a real mixture may significantly deviate from that of an ideal mixture due to the dependence of molecular interactions on the composition. As a consequence, the molar Gibbs potential of real mixtures also deviates from the ideal behavior described by (7.82). However, the equation can readily be rewritten to take into account the actual behavior, using relative activities:

$$g = \sum_{i=1}^K x_i (\mu_i^* + RT \ln a_i). \quad (7.85)$$

7.6.1 Liquid–Liquid Phase Diagrams

The concentration dependence of the activities often leads to a calculated molar Gibbs potential according to (7.85) which is not convex; it also contains a concave region as illustrated in Fig. 7.20. The left-hand panel shows the calculated molar Gibbs potentials as a function of composition, at different temperatures. Above the curve marked by T_{cr} (i.e., at lower temperatures than T_{cr}), the curves are convex; thus, the mixture phase is stable in the entire composition range. At higher temperatures than T_{cr} , the central part of the curves is unstable (concave), with adjacent metastable regions at both sides that only have local stability. Global stability is only possible if tangent lines of the entire curve always lie below the

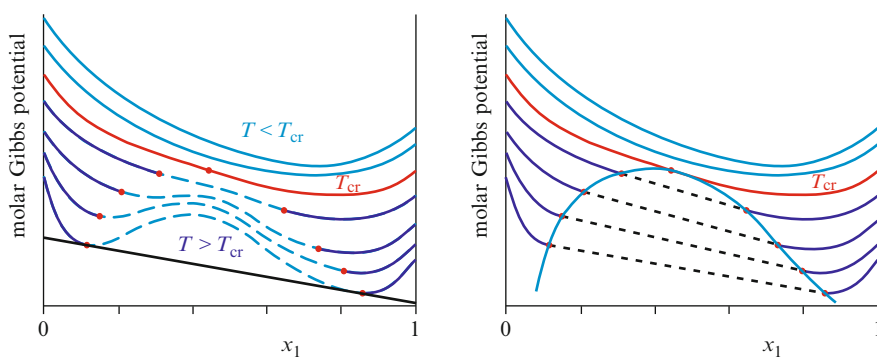

Fig. 7.20 Molar Gibbs potential of a real binary mixture of limited miscibility as a function of composition. Curves from top to bottom are related to increasing temperature. The curve marked as T_{cr} is related to the critical temperature; at lower temperatures (above this curve) the curves are convex, while at higher temperatures (below this curve) the curves are concave and exhibit two minima. The left-hand diagram shows the molar Gibbs potentials calculated using (7.85). Dashed parts of the curves between dots indicate the region of global instability. The limit of this region is shown in the right-hand diagram as a thin continuous line. Within this region, there is no stable phase but separation into two phases. The two phases are located at the points of contact of the tangent line and the calculated curve, as illustrated on the bottom curve in the left-hand diagram. Tangent points are interconnected by short-dashed lines in the right-hand diagram

curve. This condition can be fulfilled if the calculated molar Gibbs potentials in the unstable region are replaced by their lower lying tangent lines. (This principle is often referred to as the *rule of common tangents*, as the line is a common tangent of both minima.) In reality, the molar Gibbs potential according to the common tangent leads to phase separation, so that the two phases coincide with the points of contact of the tangent line and the calculated curve. The recalculated molar Gibbs potential is a linear combination of that of the two phases; thus, it exactly coincides with the common tangent. The relative quantity of the phases can be calculated from the overall composition using the lever rule (See Sect. 7.2.2).

The limit of miscibility is best visualized in a T - x phase diagram where the locations of the dots in Fig. 7.20 are at the same composition but along a constant temperature line at the temperature of corresponding molar Gibbs potential curves. The points of common tangency in the molar Gibbs potential curves are called *nodes*; therefore, the miscibility limit curve in the T - x phase diagram is referred to as *binodal* curve. The resulting phase diagram is illustrated in Fig. 7.21. An example for this behavior is the water–trimethylamine mixture with a *lower critical temperature* of 13 °C. Above this temperature, the mixture is separated into two phases.

It can be seen in Fig. 7.20 that there exist *locally stable* states in the vicinity of the points of tangency where global stability conditions do not hold. Similarly to the case of pure components where the metastable superheated liquid or supersaturated vapor can be formed (see end of Sect. 7.2), there is a possibility also in binary liquids to form locally stable but globally metastable states. In highly viscous mixtures, phase separation is largely hindered and the metastable one-phase

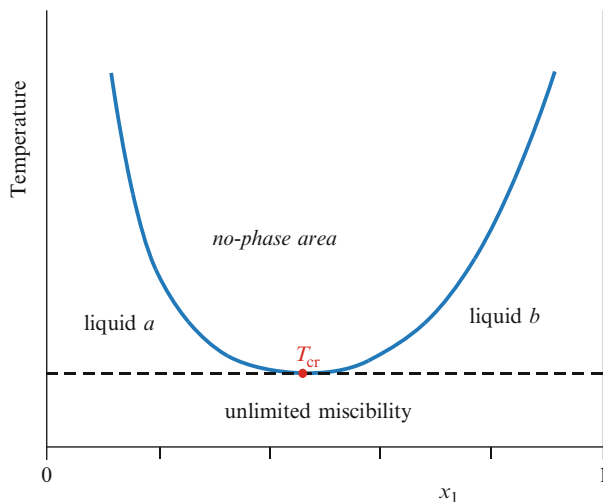

Fig. 7.21 Temperature–composition phase diagram of the same partially miscible binary mixture as in Fig. 7.20. Below the dashed line drawn at the lower critical temperature T_{cr} , there is unlimited miscibility. At higher temperatures, the mixture is separated into two phases of compositions along the thick solid line. (Note that above the critical temperature of the liquid there is no phase separation either)

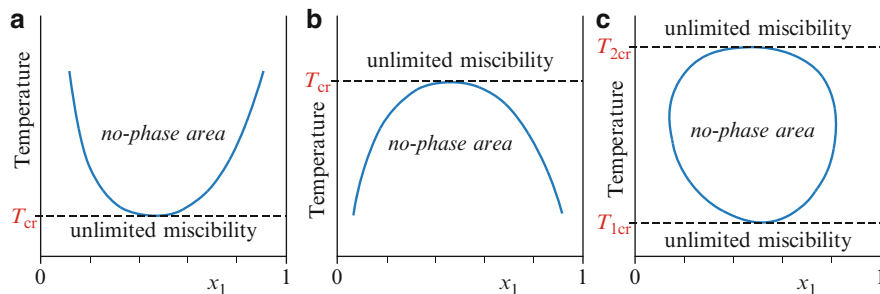

Fig. 7.22 Possible types of temperature–composition phase diagrams of partially miscible binary mixtures. Diagram (a) illustrates a mixture with a lower critical temperature. Diagram (b) shows a mixture with an upper critical temperature. Diagram (c) shows a mixture with a lower and an upper critical temperature. Beyond the *dashed lines* indicating the critical temperatures, mixing is unlimited. If the overall concentration falls in between the solid curves, phase separation occurs resulting in two immiscible phases

mixture can survive for a long time. The metastable area is located between the points of tangency and the inflexion points marking the limits of local stability.

Figure 7.21 shows the temperature–composition phase diagram of the mixture shown in Fig. 7.20. Below the dashed line drawn at the lower critical temperature T_{cr} , there is unlimited miscibility, and above this line (up to the critical temperature of the liquid where no phase separation occurs), the mixture is separated into two phases whose compositions lie along the thick solid line.

Molecular interactions in binary mixtures can result in deviations from ideality leading to different situations from that illustrated in Figs. 7.20 and 7.21. It is also possible that phase separation occurs with decreasing temperature, below an *upper critical temperature*. This is the case for the phenol–water mixture, where the system separates into two phases below the critical temperature of 68.8°C. There exist also mixtures which separate into two phases within a finite temperature range; at both higher and lower temperatures outside this range, there is unlimited miscibility of the two components. A common example for this behavior is the water–nicotine mixture with a lower critical temperature of 61°C and an upper one at 210°C. Possible types of partially immiscible liquids are illustrated in Fig. 7.22. It is worth noting that in case of the panels b) and c) of these figures it is possible to include in the same diagram the liquid–vapor equilibrium curves as well. This way, the same phase diagram can show both the liquid–liquid and the liquid–vapor phase separation equilibria.

7.6.2 Solid–Liquid Phase Diagrams

Binary systems with unlimited liquid miscibility often do not mix in solid phase, due to different crystal structures of the pure components. This is the case – among

others – for salts dissolved in water and a great number of metal alloys. When cooling these liquids, it is always one of the pure components that crystallizes at the freezing point. The freezing temperature as a function of the composition can be calculated from the chemical potentials of the components. It is clear – even without calculations – that the chemical potential of a component close to its unit mole fraction is always inferior to that of the pure component (see (6.86)). We can plot the temperature dependence of the chemical potentials of a component in the pure solid, in the pure liquid, and in the liquid mixture phase. Curves for the pure phases are identical with those in Fig. 7.5, and the chemical potential in the mixture phase will be lower than in the pure liquid. The lowering of the chemical potential increases monotonically with decreasing concentration – at least for nearly ideal mixtures. It is readily seen from Fig. 7.23 that the freezing point of the mixture also follows this lowering tendency. The same tendency applies for the other component as well; thus, the freezing point decreases with respect to the pure components when the concentration of this component decreases.

Accordingly, in the T - x solid–liquid phase diagram, freezing points decrease from the pure substances toward the center of the diagram. The two curves intersect at the composition where the chemical potential of both mixture components are identical with that of the corresponding pure solid. At this composition and temperature the liquid mixture freezes without further composition change by crystallization of both components in a pure solid (micro)phase. The solid phase is a mixture of pure microcrystals of the components. The liquid phase at this composition has

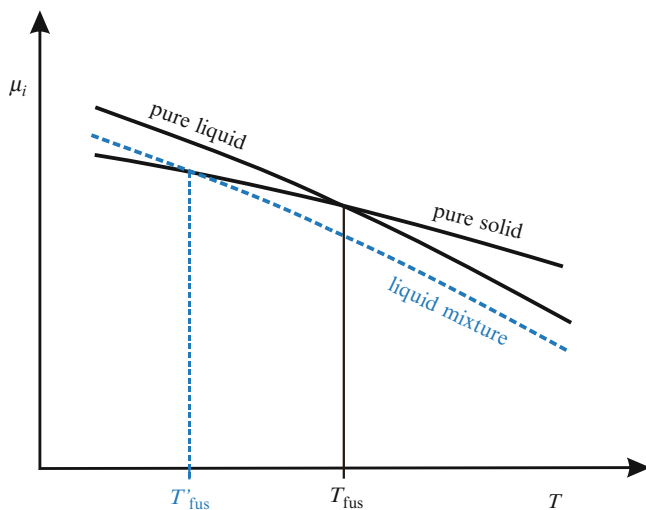

Fig. 7.23 Chemical potential vs. temperature of the major component in the liquid binary mixture, in the pure solid (freezing out from the mixture) and in the corresponding pure liquid. It can be seen that the lowering of the component's chemical potential in the mixture results in an intersection with the pure solid's chemical potential at lower temperatures than that in case of the pure liquid. As indicated, melting points change accordingly

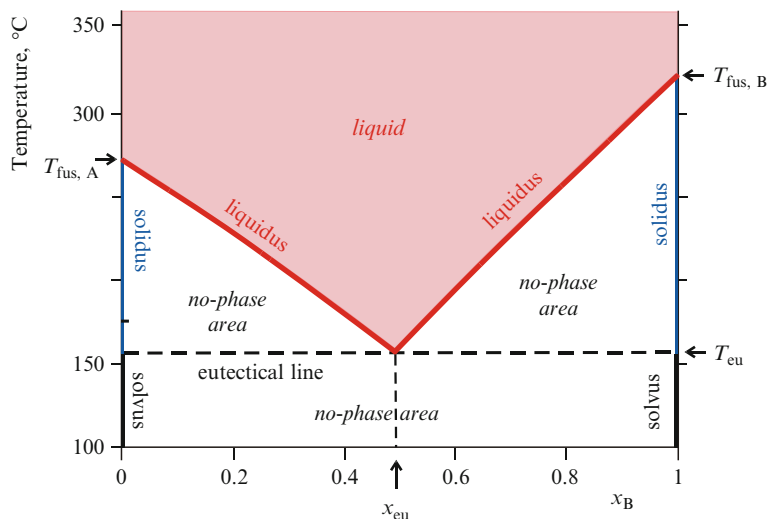

Fig. 7.24 Phase diagram of a binary system with components of unlimited miscibility in the liquid phase and no miscibility in the solid phase, forming a eutectic. Actual data are those of bismuth (A) and cadmium (B); the calculated liquidus curves and the eutectical point were obtained using relations for an ideal mixture. The Cd–Bi phase diagram is only slightly different in reality. The upper shadowed area is the stability range of the liquid phase; the white one below is a no-phase area

the lowest freezing point and the mixture crystal of the same composition has the lowest melting point. For this reason, the mixture is called the *eutectic mixture*, the temperature of solidification the *eutectic point* and the solid formed is the *eutectic* or *eutectic solid*.¹¹

A phase diagram illustrating the formation of a eutectic with no miscibility in the solid phase is shown in Fig. 7.24. Three phases may be seen in the diagram. Two of them are the pure solid substances at the left and the right edges, i.e. at $x_B = 0$ and $x_B = 1$, respectively. The third one is the liquid phase, stable above the two *liquidus curves* (or *freezing point curves*) in the entire composition range. This diagram can be constructed by calculating the liquidus curves from the condition of equilibrium. The liquidus curve indicates the composition of the liquid mixture in equilibrium with the corresponding pure solid at the given temperature. The equilibrium condition is, therefore, the equality of the chemical potential of the mixture component with that of the same component in the pure solid. By supposing an ideal mixture, let us write this equation for component A (at the left-hand side of the diagram):

$$\mu_{A,s}^*(T) = \mu_{A,l}(T, x_A) = \mu_{A,l}^*(T) + RT \ln x_A. \quad (7.86)$$

¹¹The word originates from the Greek adverb *eu* = well and the verb *τηκω* = melt. The compound word *ευτηκτος* [eutektos] means: easily melting. The English word *eutectic* is a noun and an adjective as well.

We can express the logarithm of the composition variable x_A as

$$\ln x_A = \frac{\mu_{A,s}^*(T) - \mu_{A,l}^*(T)}{RT} = \frac{\Delta_{\text{fus}} h_A^*(T)}{RT}. \quad (7.87)$$

The difference of the chemical potentials of the two pure phases is the molar Gibbs potential of fusion $\Delta_{\text{fus}} g_A^*(T)$ at the given temperature, which can be written as follows:

$$\Delta_{\text{fus}} g_A^*(T) = \Delta_{\text{fus}} h_A^*(T) - T \Delta_{\text{fus}} s_A^*(T). \quad (7.88)$$

At the melting point of the pure component, the chemical potential should be the same in both phases:

$$\mu_{A,s}^*(T_{\text{fus},A}^*) - \mu_{A,l}^*(T_{\text{fus},A}^*) = \Delta_{\text{fus}} g_A^*(T_{\text{fus},A}^*) = 0. \quad (7.89)$$

Based on this identity, we can express the molar entropy of fusion $\Delta_{\text{fus}} s_A^*(T_{\text{fus},A}^*)$ with the help of the molar enthalpy of fusion, $\Delta_{\text{fus}} h_A^*(T_{\text{fus},A}^*)$:

$$\Delta_{\text{fus}} s_{A,s}^*(T_{\text{fus},A}^*) = \frac{\Delta_{\text{fus}} h_A^*(T_{\text{fus},A}^*)}{T_{\text{fus},A}^*}. \quad (7.90)$$

Suppose that the dependence on temperature of both $\Delta_{\text{fus}} h_A^*$ and $\Delta_{\text{fus}} s_A^*$ is negligible between the temperatures $T_{\text{fus},A}^*$ and T ; thus, we can replace $\Delta_{\text{fus}} g_A^*(T)$ by

$$\Delta_{\text{fus}} h_A^* - T \frac{\Delta_{\text{fus}} h_A^*}{T_{\text{fus},A}^*} = \Delta_{\text{fus}} h_A^* \left(1 - \frac{T}{T_{\text{fus},A}^*} \right). \quad (7.91)$$

Let us substitute this into (7.87):

$$\ln x_A = \frac{1}{RT} \Delta_{\text{fus}} h_A^* \left(1 - \frac{T}{T_{\text{fus},A}^*} \right) = -\frac{\Delta_{\text{fus}} h_A^*}{R} \left(\frac{1}{T_{\text{fus},A}^*} - \frac{1}{T} \right). \quad (7.92)$$

This immediately yields the composition of the mixture in equilibrium with pure component A at temperature T :

$$x_A = e^{-\frac{\Delta_{\text{fus}} h_A^*}{R} \left(\frac{1}{T_{\text{fus},A}^*} - \frac{1}{T} \right)}. \quad (7.93)$$

While deriving the above expression, our considerations were not specific for component A. Therefore, we can write the same formula for the composition of the mixture in equilibrium with the pure solid B at temperature T :

$$x_B = e^{-\frac{\Delta_{\text{fus}} h_B^*}{R} \left(\frac{1}{T_{\text{fus},B}^*} - \frac{1}{T} \right)} \quad (7.94)$$

The phase diagram shown in Fig. 7.24 has been constructed using the two expressions above, and molar fusion enthalpies of bismuth and cadmium of 11.30 kJ/mol (at its melting point 271.4°C) and 6.19 kJ/mol (at its melting point 321.07°C), respectively. Liquidus curves calculated this way differ only negligibly from that based on measured equilibrium temperatures.

It is worth noting that the expressions obtained for the temperature-dependent solubility *do not contain* any specific data of the other component (the “solvent”). This can be generalized that if a substance forms an ideal mixture with several other substances, its solubility will be the same in all of them at the same temperature. (This is obvious at the molecular level; if the interaction of the solute molecules with those of the solvent is exactly the same as with their own molecules – which is the criterion to form an ideal mixture – then it is all the same from the point of view of mixture properties, what exactly the other molecules are.)

Phases of the diagram shown in Fig. 7.24 can be characterized as follows. Above the liquidus curves, there is only one phase, the liquid mixture. At constant pressure, the residual number of degrees of freedom is 2, which means that both temperature and pressure are free to determine to change state within this region. At the lower boundary of this region – on the liquidus curves – there are two phases in equilibrium; liquid mixture and one of the pure solids. Here, the residual number of degrees of freedom at constant pressure is only 1; therefore, we can freely choose either a temperature or a composition. At the bifurcation of the liquidus curves, there are three phases in equilibrium: liquid mixture and both pure solids, as these latter do not mix. This is a kind of “triple point” in the phase diagram having zero degrees of freedom. Consequently, the three phases coexist only at the unique *eutectic composition* and the unique *eutectic temperature*. Within the diagram, there are no other stable phases. The *no-phase area* completely fills the diagram below the liquidus curves, including the region below the eutectic temperature. This also means that the horizontal dashed line at this temperature – the *eutectic line* – is not a boundary between phases in equilibrium and only connects the compositions of the three phases in equilibrium. However, it delimits the regions of different *microcrystal structures* or *textures*. Above the line, the liquid mixture is in equilibrium with one of the pure solids, which is a homogeneous crystal. Below the line, there is a mixture crystal containing microcrystals of the two pure components.

If a liquid mixture of the eutectic composition is cooled, it is the mixture crystal of components A and B that solidifies at the eutectic temperature. If the composition of the liquid cooled is different, a pure component – A or B, depending on the actual composition – will form the solid phase first, until the composition of the liquid will become the eutectic composition. Upon further cooling, the eutectic mixture crystal structure will solidify onto the surface of the pure crystals formed before. In the completely frozen solid, there are grains of pure crystals embedded in the microcrystal structure. As a result, below the eutectic line there is always a mixture of the crystals of component A and B, while above there is always a pure component’s crystal only.

The ratio of components A and B is unique for a given binary system, according to the eutectic composition. This fact can be interpreted by writing the following “stoichiometric equation”:

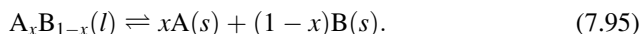

This equation contains the liquid mixture on the left side as “reactant” and the two solids on the right side as “products”. Thus, the general *eutectic reaction* can be written as follows:



We shall see similar reactions of isothermal equilibria concerning three phases later.

To calculate the eutectic temperature, we only have to make use of the fact that the two liquidus curves bifurcate at this temperature. Thus, the sum of the mole fractions of the liquid richer in A and that of the mixture richer in B is unit. Formally, we can write the equation

$$e^{-\frac{\Delta h_A^*}{R}\left(\frac{1}{T_A^*} - \frac{1}{T}\right)} + e^{-\frac{\Delta h_B^*}{R}\left(\frac{1}{T_B^*} - \frac{1}{T}\right)} = 1, \quad (7.97)$$

which yields as solution the eutectic temperature.

This equation is valid only in case of an ideal liquid solution, with the additional constraint that the enthalpy of fusion does not depend on temperature. However, we can readily take into account nonideality and the temperature dependence of the fusion enthalpy as well. Let us rewrite (7.87) for a real mixture:

$$\ln f_A x_A = \frac{\Delta_{\text{fus}} g_A^*(T)}{RT} \quad (7.98)$$

and substitute into it the temperature-dependent relative activity coefficient f_A and fusion enthalpy $\Delta_{\text{fus}} g_A^*(T)$. These data can be obtained either from detailed thermodynamic measurements or from the fundamental equation of the mixture. The modified equation provides the eutectic temperature for the real mixture.

There are binary mixtures of limited miscibility which mix to a certain degree in the solid phase as well. The difference with respect to the phase diagram shown in Fig. 7.24 is that solidus curves are not exactly at the pure components ($x_B = 0$ and $x_B = 1$) but “inside” the diagram, leaving space for the limited miscibility region in the solid phase at both edges. In metallurgy (where the two components are metals) and in mineralogy (where they are rock-forming substances), the solid solution richer in A is called α crystal and the one richer in B is called β crystal. The structure of the α crystal is the same as that of the pure component A. Similarly, the β crystal has the structure of the pure component B. They differ from the crystals of the pure components by containing the other component either in the lattice positions or between them.

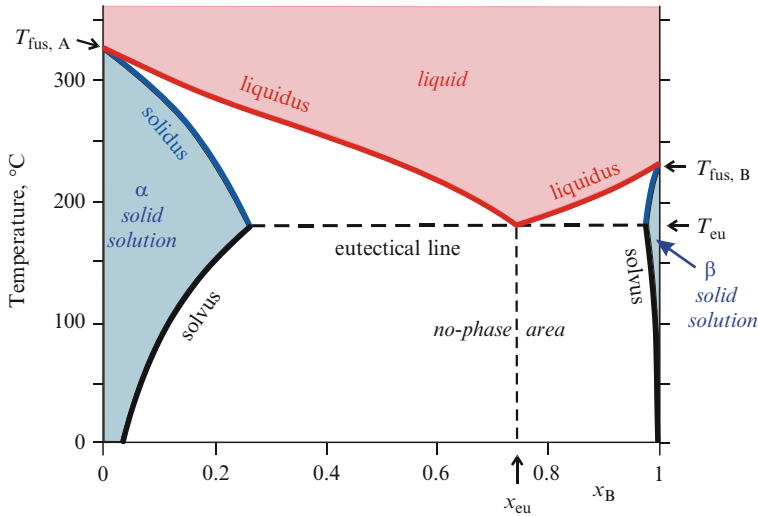

Fig. 7.25 Phase diagram of a binary system with components of unlimited miscibility in the liquid phase and partial miscibility in the solid phase, forming a eutectic. This diagram shows the case of lead (A) and tin (B), forming the common *solder* as eutectic. Shaded areas indicate the range of stable phases (liquid, lead-rich α , tin-rich β); the white area below is a no-phase area. (Note that below 13°C, the β phase is no more stable but pure tin – which is not discernable in the diagram)

In the phase diagram of such a system shown in Fig. 7.25, there are three phases; liquid mixture, solid solution α , and solid solution β . (These latter are usually called simply as α phase and β phase, respectively.) As the composition of the solids can vary within their stability range, the no-phase area is reduced compared to the case shown in Fig. 7.24. The actual composition of the solid in equilibrium with the liquid varies with temperature. The shapes of the two branches of the liquidus curve are similar to that in Fig. 7.24, and a eutectic solidifies when the composition of the liquid in equilibrium with the α phase is the same as the composition of the liquid in equilibrium with the β phase. The texture of the eutectic exhibits a fine mixture of microcrystals of the α and the β phase in a ratio corresponding to the eutectic reaction.

The equilibrium condition between the liquid and the solid solution is the equality of the chemical potentials of each component in the two phases. This condition is the basis to calculate the equilibrium temperature and concentration. We also know from earlier chapters (see e.g., Table 4.1) that the overall condition of equilibrium at constant temperature and pressure is the minimum of the Gibbs potential, or, in case of an intensive characterization only, the minimum of its molar value. The advantage of this method is that it can be used irrespective of the number of components and phases. It is easy to show that this condition is equivalent to the equality of the chemical potentials of the respective components in the phases in equilibrium.

Let us consider the Gibbs potential function $G(T, P, \mathbf{n}^{\varphi_1}, \mathbf{n}^{\varphi_2}, \dots, \mathbf{n}^{\varphi_K})$ of a system consisting of P phases and K components, where the vectors \mathbf{n}^{φ_j} describe the composition of the phase φ_j . A necessary condition of the minimum of G is that its total differential be zero. At constant temperature ($dT = 0$) and constant pressure ($dP = 0$), the total differential contains only terms with nonzero increments of the composition variables:

$$dG = \sum_{\varphi_j=1}^P \sum_{i=1}^K \mu_i^{\varphi_j} dn_i^{\varphi_j} = 0. \quad (7.99)$$

This equation can be considered as the general equilibrium condition of a multicomponent multiphase system. Let us rewrite it for a binary system:

$$\mu_A^\alpha dn_A^\alpha + \mu_B^\alpha dn_B^\alpha + \mu_A^\beta dn_A^\beta + \mu_B^\beta dn_B^\beta = 0. \quad (7.100)$$

Let us make use of the constraint that the system is closed, i.e.,

$$dn_A^\alpha = -dn_A^\beta \quad \text{and} \quad dn_B^\alpha = -dn_B^\beta. \quad (7.101)$$

By substituting this into the previous equation, we get

$$(\mu_A^\alpha - \mu_A^\beta) dn_A^\alpha + (\mu_B^\alpha - \mu_B^\beta) dn_B^\alpha = 0. \quad (7.102)$$

As dn_A^α and dn_B^α are independent and nonzero, the equation holds only if

$$\mu_A^\alpha = \mu_A^\beta \quad \text{and} \quad \mu_B^\alpha = \mu_B^\beta, \quad (7.103)$$

which demonstrates the equivalence of the equality of the respective chemical potentials to the minimum of the (molar) Gibbs potential. The latter condition is usually easier to use in case of multicomponent systems.

To get the molar Gibbs potential, we only have to divide the extensive Gibbs potential by the total amount of the system; i.e., the total mole number. The temperature dependence of the molar Gibbs function of each phase is determined by its negative molar entropy:

$$\left(\frac{dg}{dT} \right)_{P,x} = -s. \quad (7.104)$$

Based on this identity, we can conclude that the molar Gibbs potential of the phases always increases with decreasing temperature. As the molar entropy of the liquid is always greater than that of the solid of the same composition, the molar Gibbs potential of the liquid increases in a greater extent compared to that of the solid of the same composition. Consequently, the molar Gibbs potential of the

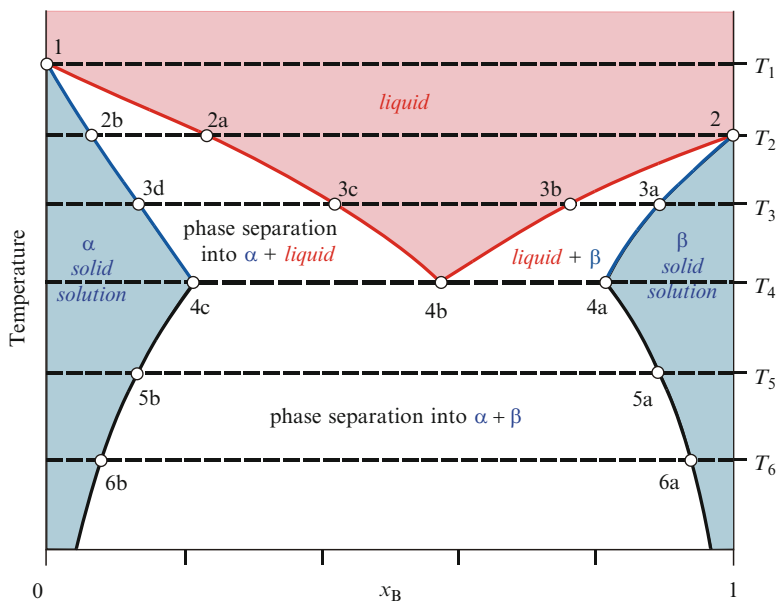

Fig. 7.26 Phase diagram of a binary system with components of unlimited miscibility in the liquid phase and partial miscibility in the solid phase, forming a eutectic. Whenever the overall composition lies within the white (non-shaded) area, the system separates into two phases interconnected by the dashed lines. Molar Gibbs-potential curves of the relevant phases at temperatures T_1 – T_6 are shown in Fig. 7.27

liquid as a function of composition shifts more and more upwards with increasing temperature compared to that of the corresponding solid. Let us analyze this behavior in a schematic phase diagram of the same type as the one in Fig. 7.25.

In Fig. 7.26, there are six different isotherms shown as horizontal dashed lines. These are conodes, interconnecting nodes representing phases in equilibrium at the given temperature, at the edges of the no-phase area. Figure 7.27 shows the molar Gibbs potentials of the phases at the same temperatures as a function of the composition. By inspecting the two figures, we can make the following observations.

At the temperature T_1 , pure liquid A solidifies; the molar Gibbs potential of the solid formed (α phase) is equal to that of the liquid. As the equality holds only for pure substance A, the crystal also consists of pure A.

At a lower temperature T_2 , it is the solid phase labeled 2b which is in equilibrium with the liquid mixture having the composition 2a. By inspecting the corresponding diagram in Fig. 7.27, we can see that, at compositions between 2a and 2b, the molar Gibbs potentials of both the liquid phase and the solid α phase are greater than that of the “mechanical dispersion” of the two phases, represented by the interconnecting line between the two points 2a and 2b. (Note that the calculation of the molar Gibbs potential of the mechanical dispersion is based on the lever rule

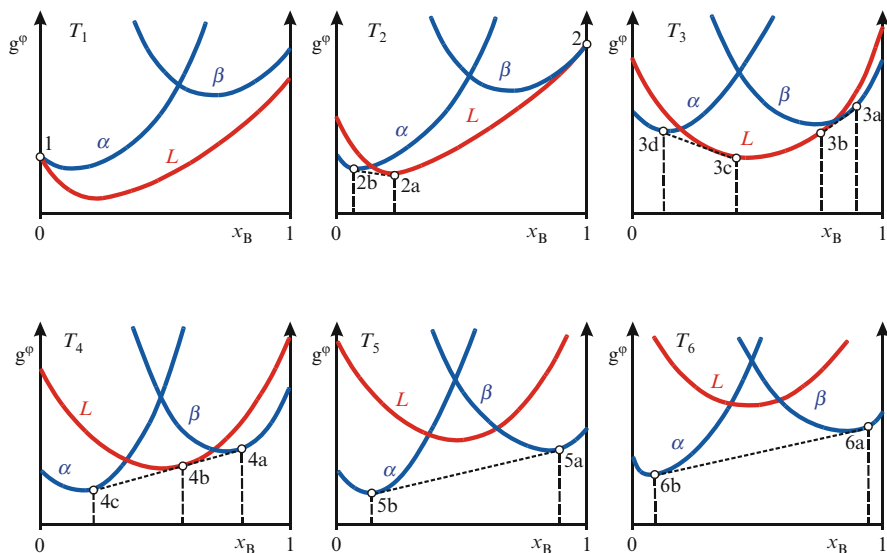

Fig. 7.27 Molar Gibbs potential g^ϕ of the phases in a binary system with components of unlimited miscibility in the liquid phase and partial miscibility in the solid phase, forming a eutectic, at temperatures shown in Fig. 7.26 as T_1 – T_6 . Phases are identified by labels above the curves (α , β , and $L = \text{liquid}$)

explained before.) This temperature is the melting point of pure B; thus, it also solidifies here, and the molar Gibbs potential of the liquid at point labeled 2 is identical to that of the β phase, which is pure component B in this case.

At the temperature T_3 , below T_2 , there exist systems of overall composition (in both regions richer in A and richer in B) where neither a liquid nor a solid of this composition is stable. Accordingly, between the overall compositions 3d and 3c, only the α phase having the composition 3d and liquid mixture having the composition 3c are stable. Similarly, between the overall compositions 3b and 3a, only the β phase having the composition 3a and liquid mixture having the composition 3b are stable. The ratio of the coexisting phases can be calculated using the lever rule.

At the temperature T_4 , the molar Gibbs-potential curves of the three phases have a common tangent. Accordingly, the solid richer in A consists of crystals of the α phase having the composition 4c and of eutectic mixture crystals containing α and β microcrystals of compositions 4a and 4c. Similarly, at overall compositions richer in B than the eutectic mixture, the same eutectic is mixed with crystals of the β phase having the composition 4a. At exactly the eutectic composition 4b, the system can exist as only liquid, or as a solid eutectic containing microcrystals of both solid phases, or all the three phases – α , β , and liquid – can coexist. This is the only “triple point” in the phase diagram shown in Fig. 7.26.

At the temperature T_5 below the eutectic temperature T_4 , the molar Gibbs potential of the liquid is greater at all compositions than that of the solid phases α and β and also greater than the common tangent of the two curves of the solids.

Therefore, the liquid phase is no more stable at this temperature. To the left of point 5b only the α phase, while to the right of point 5a, only the β phase is stable. If the overall composition lies between 5a and 5b – within the no-phase area – the system consists of a mixture crystal of the solid solutions α and β . At the still lower temperature T_6 , the situation is in principle the same except that the stability range of the two solid solutions α and β further shrinks. This can also be seen in Fig. 7.27 where the common tangent of the two curves extends to a greater interval between 6b and 6a. Within this composition range, we can find mixture crystals in the solid.

To calculate temperature-dependent molar Gibbs potentials of the phases shown in Fig. 7.27, we need to know the chemical potentials of the components in each phase – the terms in the second sum of (7.99) – as a function of temperature. To find the compositions of two (or three) phases in equilibrium, we have to find the tangency points of the common tangents on the molar Gibbs-potential curves. The necessary calculations can readily be made even in the case of more complicated phase diagrams. We shall only show a few common types of these diagrams without discussing the thermodynamic calculations.

There is also another way to construct binary phase diagrams; we can determine experimentally equilibrium temperatures and compositions in the diagram. This method is usually simpler than the thermodynamic description, which is the reason that most binary phase diagrams are known from experimental data. There are several experimental techniques providing the necessary data. Probably the most simple is the observation of cooling curves. A brief description of this method is shown in a solved problem at the end of the chapter.

It is worth while noting an interesting behavior of the binary systems characterized by the phase diagram in Fig. 7.26. Let us suppose that the liquid mixture of the corresponding composition is cooled until point 3b. Upon further cooling, it is first the solid of composition 3a that freezes out; thus, the composition of the liquid will be less and less rich in component B as we continue cooling, continuously changing along the liquidus curve toward 4b. Meanwhile, the composition of the solid also shifts along the solidus curve from 3a toward 4a. Accordingly, the first crystals formed will have the composition corresponding to 3a, but upon further cooling, the surface layers of the growing crystals will be richer and richer in component A. All layers of any composition solidified are stable until point 4a. However, as the temperature falls below T_4 , layers (or grains of crystals) richest in A gradually lose stability as their composition falls within the no-phase area. For example, at the temperature T_6 , the composition of the stable β crystal rich in A cannot lie to the left of point 6a. To maintain stability, β microcrystals or the surface layers of larger crystals formed at higher temperatures, richer in A, partly recrystallize forming α crystals of composition 6b. However, during this recrystallization the composition of the solid should change, which necessitates material transport. As diffusion in the solid state is slower by several orders of magnitude than that in the liquid state, this equilibrium is achieved only very slowly. α crystals formed this way are called *secondary crystals*. This name only refers to the process of their formation; from a thermodynamic or structural point of view, there is no difference

between them and the *primary crystals* (frozen out at temperatures higher than T_4) or eutectic microcrystals (frozen out as a mixture crystal at temperature T_4). Nevertheless, the texture – the arrangement of microcrystals and crystal layers – of these crystals of different specific history is usually different.

Another important type of binary solid–liquid phase diagrams is the case of components that form nearly ideal mixtures both at compositions rich in A and rich in B, except for the composition range where they form a compound. (The edges of the diagram at compositions rich in A and rich in B are quite similar to the shape shown in Fig. 7.18.) The compound formed does not mix with one of the components. The example shown in Fig. 7.28a) is a mixture which forms the

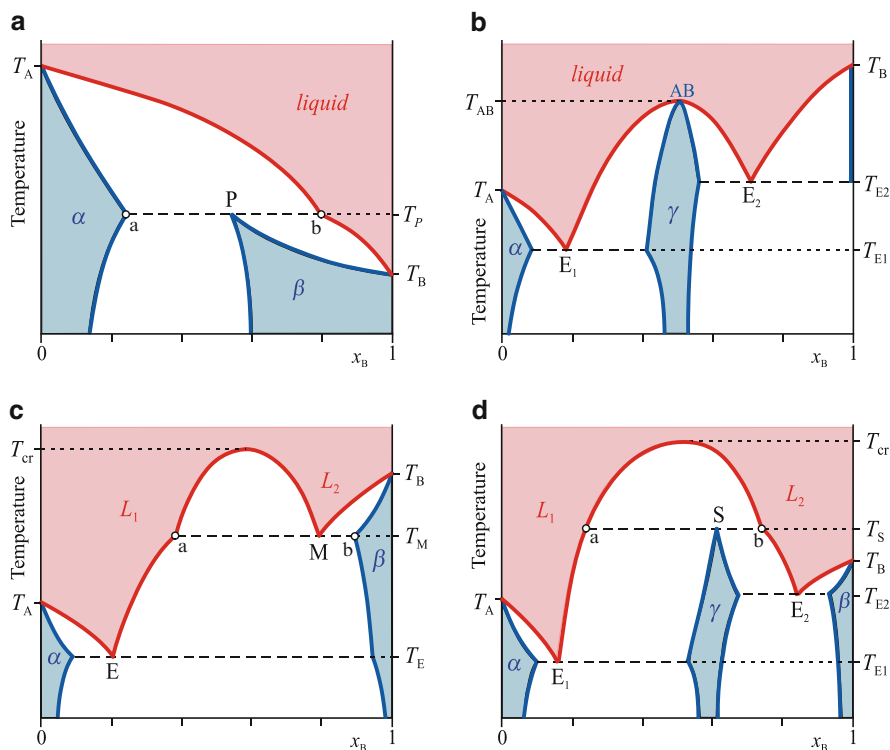

Fig. 7.28 Some further types of phase diagrams of binary mixtures with partial miscibility in the solid phase. Shaded areas indicate the range of stable phases; the white area is a no-phase area. (a) Two components of unlimited miscibility in the liquid phase with a peritectic reaction at the point P. (b) The two components form a compound AB which dissolves both components in a limited concentration in the solid (γ) phase. Component A can dissolve some B in the solid phase (α), but B is immiscible with A in the solid phase. Both α and γ , and γ and pure solid B, form eutectics. (c) The two components are also only partially miscible in the liquid phase with a monotectic reaction at the point M and a eutectic reaction at the point E. (d) The two components are also only partially miscible in the liquid phase with a syntectic reaction at the point S and eutectic reactions at points E_1 and E_2

compound A_2B_3 . At the temperature T_P , it is a solid solution containing mostly this compound that is formed in a reaction between the liquid mixture (L) and the solid α phase. This is called a *peritectic*¹² reaction and can be written in a general form:



In the figure shown, solid_1 is the α phase and solid_2 is the β phase. The liquidus curve is T_A-b-T_B and the solidus curve is T_A-a . On cooling a liquid mixture of concentration x_B to the left of point b, upon intersection of the liquidus, α phase will freeze out. (Its composition can be found by the intersection of the isothermal conode and the solidus.) As cooling continues, the liquid becomes richer in B, just like the new layers of the growing crystals, until the temperature T_P is reached. At this temperature, the composition of the liquid corresponds to point b and the peritectic reaction occurs. During the reaction, part of the solid α phase and all the liquid is transformed into the solid β phase consisting mostly of the compound A_2B_3 . If the solvus curve delimiting phase stability below point P was vertical or was tending to the left with lowering temperature, its composition would remain the same upon further cooling. However, the change of activities with temperature in the figure is such that further cooling results in forming some α phase from the β phase during recrystallization of a small fraction of the latter.

On cooling a liquid mixture of composition falling between the points P and b, the only difference is that at the completion of the peritectic reaction there is still some liquid remaining. Upon further cooling, its composition will change along the curve $b-T_B$ and the composition of the freezing solid along the curve $P-T_B$. The same happens also when cooling a liquid mixture of composition to the right of b. The horizontal line $a-P-b$ (dashed in the figure) at temperature T_B is called the *peritectic line*. This only delimits solids of different textures and not different phases, as is the case with the eutectic line. Binary mixtures exhibiting peritectic reactions are, for example, the Al-Ti and Fe-C systems and several water-salt systems forming water containing crystals.

In partially miscible binary systems, interaction of the molecules A-B might exceed significantly both interactions A-A and B-B, leading to strongly nonideal behavior. This may result in the formation of a stable compound between A and B, which is completely immiscible or partially immiscible with the pure components. The formation of the compound is a chemical reaction in the classical sense as stoichiometric coefficients in the equations are small integer numbers (e.g., AB, AB_2 , A_2B , and A_3B_2). These compounds can directly crystallize from the liquid mixture according to the reaction

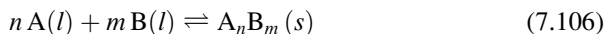

¹²The word has been coined by analogy with eutectic. The first part is the Greek preposition $\pi\epsilon\rho\iota$ which means "around". The second part is the verb $\tau\eta\kappa\omega$ = melt. The compound word reflects the fact that the composition of the liquid in equilibrium with the two solid phases lies outside ("around") the interval determined by the compositions of the solids, not between them.

On the left-hand side, there is only the liquid phase, while on the right-hand side, there is only the solid phase. Accordingly, a usual simplification of the “reaction” can be written as



which reflects that the liquid corresponding to a ratio $n : m$ freezes out without any composition change. (This is also called *congruent freezing*.) At this temperature, the composition of the liquid and the solid are the same, while at slightly lower temperatures this is not the case. As it is shown in Sect. 7.4, both liquidus and solidus should have a maximum at this temperature, which means that their common tangent line is horizontal at this particular composition.

Among binary phase diagrams of components forming a compound, we can find cases where the compound does not mix at all with the pure components in the solid phase, and other cases where the solid compound dissolves some of the pure components. In the latter case, the stability range of the compound extends to the left and right of the composition of the compound (see Fig. 7.28b). Pure components A and B usually do not dissolve the compound as the compound does not “fit” into their crystal structure. Therefore, if an α or β mixture phase appears close to the pure components, they usually contain pure B or pure A, respectively, instead of the compound. The example in Fig. 7.28b) shows the case where the (solid) compound AB dissolves both A and B to form the γ phase. Component A can dissolve some B in the solid phase; thus, we can see a stability range of the α phase. Pure B cannot dissolve A; thus, there is no β phase in the diagram; the solidus at the right edge is a vertical line representing pure B only.

Some binary mixtures exhibit partial miscibility not only in the solid but also in the liquid phase. Two types of such phase diagrams are shown in Fig. 7.28c and d, where the liquid separates into two phases below the critical temperature T_{cr} . In the diagram (c), there are only two solids α and β that can freeze out from the liquid. In the diagram (d), a third solid γ can also solidify from the two immiscible liquids L_1 and L_2 . The γ phase consists of the compound A_2B_3 and can dissolve some of both pure components.

At point M of diagram (c) a *monotectic reaction*¹³ takes place, which can be written in a general form as follows:

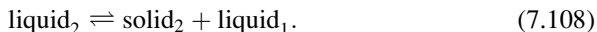

In the diagram shown, solid_2 is the β phase and the two liquids are L_1 and L_2 . Upon cooling the liquid L_2 at point M, the monotectic reaction yields the β phase of composition b and the liquid L_1 of composition a, until no L_2 remains. Upon further

¹³This word has also been coined by analogy with eutectic. The first part is the Greek adverb *μovo* [mono] which means “only (one)”. The second part is the verb *τηκω* = melt. The compound word reflects the fact that one of the two liquids disappears during crystallization, another liquid and one solid survives.

cooling the composition of the liquid L_1 shifts along the liquidus curve toward point E, where a eutectic reaction takes place and the composition remains unchanged during solidification. The dashed horizontal line a-M-b at temperature T_M is called the *monotectic line*.

At point S of diagram (d) a *syntectic reaction*¹⁴ takes place, which can be written in a general form as follows:

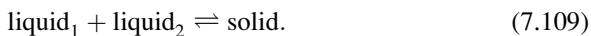

In the diagram, solid_2 is the γ phase and the two liquids are L_1 and L_2 . Upon cooling, the liquid L_1 of composition a and the liquid L_2 of composition b yield the solid γ phase of composition M at constant temperature T_S until one of the two liquids is entirely transformed. Upon further cooling either α or β phase freezes out, depending on the composition of the remaining liquid. During this process, the composition shifts either toward E_1 or E_2 , respectively, where the liquid solidifies in the corresponding eutectic reaction. The dashed horizontal line a-S-b at temperature T_S is called the *syntectic line*.

It is useful to comment on transitions of fixed temperature in the phase diagrams in Fig. 7.28. In the diagram (b), the solid compound AB is formed upon cooling and disintegrates upon heating, while both the solid AB and the liquid mixture are present. The rationale for constant temperature during congruent melting is that both solidus and liquidus have a maximum. The peritectic, monotectic, and syntectic reactions in case of the other three diagrams take place in the presence of three phases. The phase rule for two components in this case prescribes one degree of freedom, thus a unique temperature and composition at constant pressure – similarly to the eutectic reaction. It is worth mentioning that three of these reaction types have their analogues where the solution reaction partner is also a solid, instead of a liquid. These reactions are called *eutectoid*, *peritectoid*, and *monotectoid*.

There exist more complicated phase diagrams than the above-described types. Though they contain more solid phases, they can be constructed from the elements discussed before. Irrespective of the complexity of a binary solid–liquid phase diagram, its interpretation is relatively simple based on the principles explored in this chapter. We can summarize a few general rules that always apply.

- Starting from a pure component, moving toward the other component along an (horizontal) isotherm, the first phase is a stable one, followed by a no-phase area, then comes a stable phase again, then a no-phase area, etc. If the overall composition lies within the no-phase area, the system separates into the adjacent two stable phases. At the other edge of the diagram, there is also a stable phase. (The stable phase close to the pure component can be a vertical line

¹⁴This word has also been formed by analogy with eutectic; from the Greek preposition $\sigma\upsilon\nu$ which means “together” and the verb $\tau\eta\kappa\omega$ = melt. The compound word reflects the fact that the two liquid phases crystallize together and yield one solid phase.

corresponding to the pure component only.) The isotherm of a three-phase reaction is an exception from this rule; across the no-phase area, we can find a particular point where a third (stable) phase is also present.

- According to the phase rule, at the overall composition within a no-phase area, the maximum number of phases is three. Consequently, at any (overall) composition, the number of phases can be 1, 2, or 3. If we cross a curve delimiting the stability range of a phase (even if diagonally) in the phase diagram, the number of phases in equilibrium always changes by one. (It can increase or decrease by one.)
- The number of solidus–liquidus pairs (connected directly by isotherms as tie lines or conodes) equals the number of solid phases that can freeze out from the liquid mixture.
- Above the liquidus curve there is always a stable phase: the liquid mixture.
- Below the solidus curve there is always a stable phase: the solid solution.
- Below the eutectical line there is always a heterogeneous mixture of solid phases.
- Above the monotectical line there is always a no-phase area according to the equilibrium of two liquid phases.
- Above the peritectical line there is always a no-phase area according to the equilibrium of a liquid and a solid phase.

7.6.3 *Colligative Properties: Equilibrium of a Binary Mixture Phase and a Pure Phase Containing One of the Mixture Components*

There is a special type of phase equilibria where a binary mixture is in equilibrium with one of its pure components. If the mixture phase behaves ideally to a good approximation, a number of thermodynamic properties can be characterized in a similar way. This is the reason they are called *colligative properties*.¹⁵ Prior to the thermodynamic characterization, let us overview these systems and their relevant properties. In the first column of Table 7.1, we can find the two phases in equilibrium, while the second column contains the property modified in the mixture phase with respect to the pure component.

It can be seen from the table that the boiling point of the liquid mixture is higher than that of the pure liquid, if the other component dissolved in the pure liquid does not evaporate; i.e., it is not present in the vapor phase. At the same time, the vapor pressure of the mixture also decreases relative to that of the pure liquid. The freezing point of the mixture phase is also lowered relative to the freezing point

¹⁵The word *colligative* originates from the Latin verb *colligo*, meaning to bind or fasten together. As the word has a figurative sense of “united in a class”, it refers to the fact that the thermodynamic description of these properties is closely related; namely these properties depend on the molar concentration of the solute, irrespective of its chemical nature.

Table 7.1 Different cases of equilibria of a mixture phase and a pure phase

Phases in equilibrium	Property due to the equilibrium
Liquid mixture–pure vapor	Elevation of the boiling point; decrease of the vapor pressure
Solid mixture–pure vapor	Elevation of the sublimation point; decrease of the vapor pressure
Liquid mixture–pure solid	Depression of the freezing point
Liquid mixture–pure liquid (solvent)	Osmosis
Vapor mixture–pure vapor	Porous diffusion

of the pure liquid. The vapor pressure of a solid mixture is also lower if only one of the components evaporates from the mixture, and its sublimation point will be elevated. The last two rows of the table refer to equilibria across *semipermeable* membranes. If two liquid phases are separated by a membrane through which only one of the components is able to diffuse but the other not, we speak of *osmosis*. If the two phases are gases, the phenomenon is called *porous diffusion*.

Even in the absence of a semipermeable membrane, other cases shown in the table also refer to equilibria where only one of the two components can freely move between the two phases. Consequently, the equilibrium condition is the same as already stated in Sect. 3.3; the freely moving component should have the same chemical potential in equilibrium in both phases. By supposing that component A is present in both phases, the general equation describing colligative properties can be written as follows:

$$\mu_{A,\text{pure}}^*(T, P) = \mu_{A,\text{mixture}}(T, P, x_A). \quad (7.110)$$

Let us recall that two cases included in the table – the decrease of the vapor pressure and the depression of the freezing point – are already discussed in previous sections. To calculate the decrease of the vapor pressure, in analogy of (7.51), we can start with the equilibrium condition

$$\mu_{A,\text{vapor}}^*(T, p^*) + RT \ln \frac{p_A}{p^*} = \mu_{A,\text{liquid}}^*(T, p^*) + RT \ln x_A, \quad (7.111)$$

where p^* is the equilibrium vapor pressure of the pure liquid at temperature T . We can write a similar equation for the equilibrium of the pure liquid and its vapor:

$$\mu_{A,\text{vapor}}^*(T, p^*) = \mu_{A,\text{liquid}}^*(T, p^*). \quad (7.112)$$

By subtracting this from the previous equation, we get the vapor pressure of pure component A in equilibrium with the liquid mixture of composition x_A :

$$p_A = x_A p^*. \quad (7.113)$$

As expected, the result is the same as Raoult's Law stated in (7.54); this is also the partial pressure of component A in the vapor. The only difference is that, in this case, p_A is also the total pressure of the liquid, as the other component does not evaporate.

The depression of the freezing point can also be calculated from the previously used condition of (7.86). The resulting (7.92) has been used to calculate the composition at the freezing point of the liquid; now we want to calculate the freezing point from the known composition. To do this, let us rewrite (7.92):

$$\frac{1}{T_{\text{fus,A}}^*} - \frac{1}{T} = -\frac{R}{\Delta_{\text{fus}} h_A^*} \ln x_A. \quad (7.114)$$

In addition to the approximations used to get this equation (the dependence on temperature of $\Delta_{\text{fus}} h_A^*$ is negligible between the melting point $T_{\text{fus,A}}^*$ of pure component A and that of the mixture, T), let us suppose that the concentration x_A is close to unity. This enables us to approximate the logarithm of the concentration expressed with the other component's mole fraction, $1 - x_B$ by the first-order term of its power series:

$$\ln x_A = \ln(1 - x_B) \cong -x_B. \quad (7.115)$$

The difference of the inverse temperatures can be approximated on the same basis; if x_A is close to unity, then the difference of the inverse of $T_{\text{fus,A}}^*$ and T is close to zero, and the product of $T_{\text{fus,A}}^*$ and T in the denominator can be replaced by $T_{\text{fus,A}}^*$ squared:

$$\frac{1}{T_{\text{fus,A}}^*} - \frac{1}{T} = \frac{T - T_{\text{fus,A}}^*}{T T_{\text{fus,A}}^*} \approx \frac{T - T_{\text{fus,A}}^*}{(T_{\text{fus,A}}^*)^2}. \quad (7.116)$$

Let us write the depression of the freezing (melting) point as $\Delta_{\text{fus}} T = T_{\text{fus,A}}^* - T$. Using the two additional approximations, we can rewrite (7.114) as

$$\Delta_{\text{fus}} T = \frac{R (T_{\text{fus,A}}^*)^2}{\Delta_{\text{fus}} h_A^*} x_B. \quad (7.117)$$

The depression of the freezing point expressed this way was used to determine the molar mass of a new compound until the mid-twentieth century. In order to use the above equation for this purpose, we can transform it into a more "user-friendly" form using molality instead of mole fraction. To do this, let us use another approximation; when calculating the mole fraction, let us neglect the amount of n_B in the denominator based on the fact that it is much less than n_A :

$$x_B = \frac{n_B}{n_A + n_B} \approx \frac{n_B}{n_A}. \quad (7.118)$$

This approximation is equivalent to the supposition that x_B moles of component B are dissolved in 1 mol of component A, which in turn is equivalent to $m_B = x_B/M_A$ moles of B dissolved in 1 kg of A. (M_A is the molar mass of the solvent A, while m_B is the molality of the solute B.) Thus, let us write $x_B = m_B/M_A$ into the expression of the freezing point depression, and let us use a simplified notation:

$$\Delta_{\text{fus}} T = \frac{R (T_o^*)^2 M_o}{\Delta_{\text{fus}} h_o^*} m. \quad (7.119)$$

In this expression, the subscript o refers to the (pure) solvent and $\Delta_{\text{fus}} T$ is proportional to the molality m of the solvent. According to this “user-friendly” formula, we measure a given mass of an unknown substance in 1 kg of solvent, and we can get the result from measuring the depression of the freezing point of this solution that this mass is m moles. The molar mass of the unknown substance can readily be calculated from these results.

We can again see from the above expression that the depression of the freezing point does *not* depend on the nature of the *dissolved component* but is simply proportional to its molality. It is also clear that the proportionality coefficient depends on the nature of the *solvent*; on its enthalpy of fusion, molar mass, and melting point. This is in accordance with the statement of the depression of freezing point of components immiscible in the solid phase already given in Sect. 7.6.2.; in an ideal mixture, the freezing point of the mixture *does not depend* on any specific data of the solute, only on its concentration.

It will turn out that all the colligative properties depend only on the nature of the solvent and not on that of the solute. A common textbook error is to say that they depend on the *quantity* of the solute, but this is not correct, as if the “quantity” of the solute (i.e., its concentration) changes, the concentration of the solvent also changes. The correct statement is that *colligative properties depend on the nature and concentration of the solvent only*, but do not depend on the nature of the solute.

The equilibrium resulting in the elevation of the boiling point can be treated similarly as the case of the freezing-point depression. The condition of equilibrium between the corresponding phases is

$$\mu_{A,g}^*(T) = \mu_{A,l}(T, x_A) = \mu_{A,l}^*(T) + RT \ln x_A. \quad (7.120)$$

Similarly to (7.87), this can also be written as

$$\ln x_A = \frac{\mu_{A,g}^*(T) - \mu_{A,l}^*(T)}{RT} = -\frac{\Delta_{\text{vap}} g_A^*(T)}{RT} \quad (7.121)$$

and further rewritten, in analogy to (7.92), as follows:

$$\left(\frac{1}{T_{\text{boil}, A}^*} - \frac{1}{T} \right) = -\frac{R}{\Delta_{\text{vap}} h_A^*} \ln x_A. \quad (7.122)$$

By applying similar approximations as for the calculation of the freezing-point depression (the dependence on temperature of $\Delta_{\text{vap}} h_A^*$ is negligible between the boiling point $T_{\text{boil,A}}^*$ of pure component A and that of the mixture, T ; the concentration x_A is large enough to approximate the logarithm of $1 - x_B$ by the first-order term of its power series, $-x_B$; and $T_{\text{boil,A}}^*$ and T are only negligibly different to replace $T_{\text{boil,A}}^* T$ by $(T_{\text{boil,A}}^*)^2$), the elevation of the boiling point is given by

$$\Delta_{\text{boil}} T = \frac{R (T_{\text{boil,A}}^*)^2}{\Delta_{\text{vap}} h_A^*} x_B. \quad (7.123)$$

This expression can also be transformed into a “user friendly” form to calculate the molar mass of an unknown substance from the elevation of the boiling point. Based on the low value of x_B (close to zero), using the approximation of (7.118) we get

$$\Delta_{\text{boil}} T = \frac{R (T_o^*)^2 M_o}{\Delta_{\text{vap}} h_o^*} m. \quad (7.124)$$

The subscript o refers to the (pure) solvent with its boiling point T_o^* and $\Delta_{\text{vap}} T$ is proportional to the molality m of the solvent.

By comparing the above equation with (7.119), we can see that, in addition to a very similar thermodynamic description, final results for the depression of the freezing point and for the elevation of the boiling point are very much similar. The coefficients of the molality m_B in both formulae depend only on the properties of the solvent; thus, we can find them for many solvents in thermodynamic tables. They also have distinct names; $\frac{R (T_o^*)^2 M_o}{\Delta_{\text{fus}} h_o^*}$ is called the *cryoscopic constant*¹⁶ and $\frac{R (T_o^*)^2 M_o}{\Delta_{\text{vap}} h_o^*}$ is called the *ebullioscopic constant*.¹⁷

For the elevation of sublimation point, we can get a formally equivalent relation as for the elevation of boiling point; the two equilibria differ only in the physical state of the mixture, which is solid in case of sublimation. Consequently, the emerging formula contains data related to sublimation instead of evaporation. The elevation of sublimation point is less important in practice than other equilibria considered before.

All the approximations applied deriving the previous results are justified if the concentration of the solution does not exceed about 0.01 mol/dm³. In this case, the use of only the first term in the series of the logarithm, and the simplification of the calculation of mol fraction do not result in a significant error; the

¹⁶The word was coined from the Greek noun *κρυος* = freeze and the verb *σκοπεω* = look or investigate. Accordingly, *cryoscope* is the apparatus to measure the freezing point and *cryoscopic constant* gives the depression of freezing point relative to unit molality.

¹⁷The word *ebullioscope* was coined in analogy of *cryoscope* from the Latin verb *ebullire* = boil, a derivative of the noun *bulla* = bubble. It is the apparatus to measure the boiling point. Similarly, *ebullioscopic constant* gives the elevation of boiling point relative to unit molality.

equilibrium temperature difference is also small enough to use the square of the respective equilibrium temperature for the pure component, and the temperature dependence of the transition enthalpies can also be neglected. All calculations can, of course, be performed without any approximations using actual activities instead of the mole fraction x_A , taking into account the temperature dependence of transition enthalpies and avoiding approximations used to calculate the logarithm and the molar concentration.

Besides the ancient method to determine the molar mass of unknown substances, there are a number of practical applications related to colligative properties. On preparing dishes, we often boil food in water to make it easily digestible but also more valuable from a gastronomic point of view. Salting the water not only improves taste but increases the boiling point, thus shortening cooking time. Spreading salt in snowy roads decreases the melting point, thus eliminating freezing. However, it has a side effect in addition to pollution and corrosion; by decreasing the vapor pressure, drying of the road is slowed down; thus, the road remains moist longer than without salt. (Snow removal is more efficient.)

Osmosis¹⁸ also has plenty of practical applications, but let us first discuss its thermodynamics. It is an equilibrium between two liquid phases separated by a semipermeable membrane through which only one of the components – the solvent – is able to diffuse but the other – the solute – not. If the container of the mixture and the membrane is not flexible, the solvent will diffuse into the mixture across the membrane until the elevation of the pressure renders the chemical potential of the solvent in the mixture equal to that of the pure solvent. (A flexible membrane would be deformed until all of the pure solvent would diffuse into the mixture.) The condition of equilibrium is the equality of the chemical potential of the solvent across the membrane, achieved by the extra pressure π due to the osmosis:

$$\mu_o^*(T, P) = \mu_o(T, P + \pi, x_o) = \mu_o^*(T, P + \pi) + RT \ln x_o. \quad (7.125)$$

Let us write the pressure dependence of μ_o^* , the chemical potential of the pure solvent, explicitly into the equation. This can be done using (6.13), which can be written at constant temperature as follows:

$$d\mu_o^*(T) = V_o^* dP. \quad (7.126)$$

Accordingly, the pressure dependence can be calculated by the integral

$$\mu_o^*(T, P + \pi) = \mu_o^*(T, P) + \int_P^{P+\pi} V_o^* dp. \quad (7.127)$$

¹⁸The Greek noun $\omega\sigma\mu\omicron\varsigma$ = thrust is a derivative of the verb $\omega\theta\epsilon\omega$ = push. It refers to the increased tension of the mixture as a consequence of diffusion across the semipermeable membrane.

Supposing V_o^* – the molar volume of the pure solvent – to be independent of pressure between P and $P + \pi$, the result of the integration is πV_o^* and (7.125) can be written as

$$-RT \ln x_o = \pi V_o^*. \quad (7.128)$$

We could already express the *osmotic pressure* π from the above equation, but we can also apply approximations used to describe other colligative properties. Supposing that the mole fraction x of the solvent is small enough to approximate the logarithm $\ln x_o = \ln(1 - x)$ with the first term of the power series $-x$, we can write:

$$\pi \cong \frac{RT}{V_o^*} x. \quad (7.129)$$

We can also approximate the mole fraction $x = n/(n + n_o)$ by the ratio n/n_o , and the molar volume V_o^* by the ratio V/n_o . V is the volume of the *solvent*, but it is not much different from the volume of the *solution*. As a result, we get

$$\pi \cong \frac{nRT}{V} = cRT. \quad (7.130)$$

Within the approximations used, the osmotic pressure can be considered to be proportional to the molarity c of the solvent. The left-side equality is called the *van't Hoff equation*. It suggests that the solute in an ideal mixture behaves as if it were an ideal gas filling in the volume of the solution.

It is worth recalling that the approximations leading to this simple formula are valid to a reasonable precision if the concentration is below of about 0.01 mol/dm^3 . In this case, the use of only the first term in the series of the logarithm and the simplification of the calculation of the mole fraction do not result in a significant error, the solution behaves nearly ideally, and the pressure dependence of the molar volume can also be neglected when performing the integration. Of course, the calculations can be performed without any approximations using actual activities instead of the mole fraction x , taking into account the pressure dependence of the molar volume (using compressibility data) and avoiding approximations used to calculate the logarithm and the molar concentration. Thus, it is also feasible to calculate the osmotic pressure of highly concentrated solutions. Osmotic pressure measurements compared to calculations for an ideal mixture can be used to determine deviations from the ideal behavior, which enables to calculate activity coefficients. The corresponding apparatus is called an *osmometer*.

Results obtained above for one single solute in an ideal solution are valid also for multiple solute components if they cannot diffuse across the membrane, as colligative properties depend only on the *concentration* of the solute, not on its chemical nature. Thus, using the *total mole fraction* of the solutes in a multicomponent system, the osmotic pressure with the ideal approximation can be calculated.

Osmotic pressure plays a major role in cell viability. Cells in an aqueous environment having smaller molar concentration of solutes than the liquid inside the cell (this is called a *hypotonic* solution) are swelled due to osmosis, or they can eventually burst. In a *hypertonic* solution – having higher molar concentration of the solutes than the medium inside the cell – cells shrink and become wrinkled due to the outward diffusion of water. The same phenomenon can be observed in case of macroscopic membranes in living organisms. Fruits conserved in hypertonic sugar solutions become raisined. Contrarily, if the sugar solution is hypotonic, fruits swell and eventually burst. Conservation in sugar solution is also due to osmosis; cells of bacteria and fungi get “dried out” in the concentrated solution and they die. Cell membranes are semipermeable not only for water but for a number of other compounds, depending on the cell. Regulation of the membrane permeability is an important means of normal physiological functionality of the cell. Coming back to cooking; it is useful to boil food in salted water also in order to avoid leaking out of minerals, thus retaining more natural taste of vegetables and meat. (Salt can also diffuse into the boiled food if membranes allow this transport.)

The above-described natural direction of osmosis can also be reversed; applying a greater pressure on the solution than the equilibrium osmotic pressure, the chemical potential of the solvent becomes greater than in the pure solvent. As a consequence, the solution becomes more concentrated and pure solvent diffuses across the membrane. This is called *reverse osmosis* and can be used, e.g., to concentrate fruit juices without heating them or for desalinating seawater to get drinking water.

Porous diffusion does not have an important practical impact. Pressure differences occurring between a gas mixture and a pure gas across a membrane can be calculated similarly as in the case of osmosis.

7.7 Phase Diagrams of Multicomponent Systems

The phase diagram of a single component containing most information is a three-dimensional P – V – T surface. Usual phase diagrams are two-dimensional projections of this surface; most of the time into the P – T plane (cf. Figs. 7.4 and 7.6). In case of a binary system, this reduced P – T plot is no more suitable to display the stability areas in two dimensions, as there is a third variable: composition. Accordingly, binary phase diagrams discussed in Sects. 7.3–7.6 are sections of a three-dimensional surface; either P – x diagrams at constant temperature or T – x diagrams at constant pressure. In case of three components (in a *ternary* mixture), even the composition cannot be displayed on a single axis. There is a possibility to maintain the concentration of one of the components constant, which enables to scale an axis with one of the remaining concentrations which also determines the third concentration. The resulting phase diagram is similar to a binary phase diagram, but only at one single value of the third component’s concentration. A more common practice is to plot the concentrations of all the three components in a plane. There are several

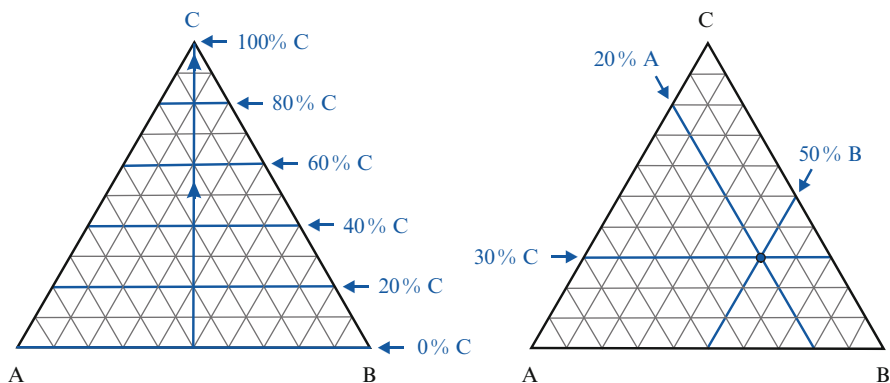

Fig. 7.29 Composition of three-component systems in an equilateral triangular diagram. The concentration scale of component C is shown in the left diagram. *Arrowheads* along the altitude of the triangle show the direction of increasing concentrations. A mixture containing 20% of A, 50% of B, and 30% of C is shown as a dot at the intersection of scaling lines in the right diagram

possibilities to do this, of which the most frequent is an equilateral triangle in which each apex represents a pure component. Figure 7.29 illustrates this kind of plot.

At the left-hand side, the concentration scale of component C is shown. The apex labeled C corresponds to 100% of C, i.e., it is pure component C. Points on the edge opposite to C contain 0% of C; here we find binary mixtures containing A and B only. The concentration of C increases linearly along the altitude connecting the base AB with the apex C. (Arrow heads along the altitude indicate the direction of increasing concentrations.) Note that the concentration scale can also be associated with the edges adjacent to the apex C, i.e., to AC and BC. Actual values are at the intersection of the lines parallel to the base AB with the respective edges. (The scale is indicated along the edge BC.) We can similarly interpret the concentration of the other two components by rotating the altitude and the lines perpendicular to it. This is the reason to use the equilateral triangle instead, e.g., a right-angled isosceles triangle; concentrations of all the three components are equivalently treated.

To construct a constant-pressure ternary $T-x$ phase diagram, we can use a uniform triangular prism where the vertical axis perpendicular to the base equilateral triangle is the temperature. Figure 7.30 shows the liquid–vapor phase diagram of an ideal ternary mixture in this coordinate system. The complete tridimensional $T-x$ diagram can be seen in panel (a) along with a constant temperature plane and the projection of the section by this plane to the base of the prism. The projection of this constant temperature section is depicted separately in an equilateral triangular diagram (same as the base of the prism) in panel (b).

Inspecting the tridimensional diagram we can find on both sides above AB and BC – representing the corresponding binary mixtures – the well-known boiling point curve and dew point curve characteristic of ideal binary mixtures, similar to the system shown in Fig. 7.13. (Were it not hidden, we could see the same curves above AC as well.) Along the edges of the prism, boiling points of the three pure

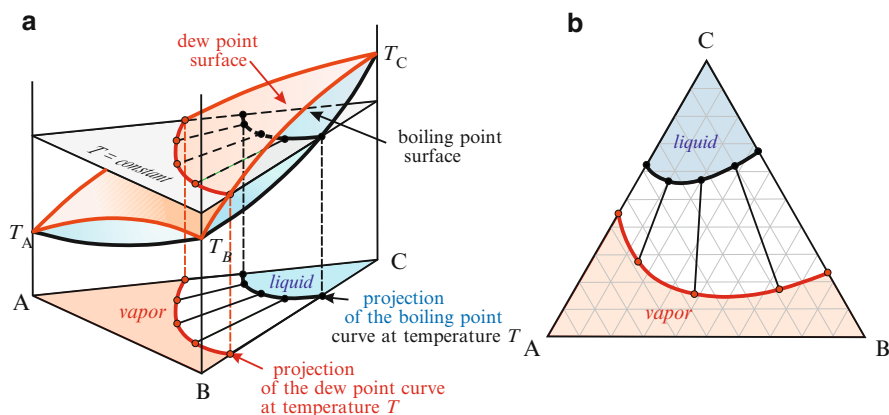

Fig. 7.30 Phase diagram showing liquid–vapor equilibrium in the ternary system of components A, B, and C. (a) Composition is given in an equilateral triangle; temperature scale is along the vertical axis. The upper (concave) surface shows the equilibrium temperature as a function of the vapor composition, and the lower (convex) surface as a function of the vapor composition. The section made by a plane of constant temperature is projected onto the base of the diagram. (b) Plot of the constant temperature section in a triangular diagram. The lower shadowed area is the stability range of the vapor phase; the upper one is that of the liquid phase. The white region between them is a no-phase area. A few conodes (or tie lines) connecting the compositions of phases in equilibrium are shown in both diagrams (a) and (b)

components (T_A , T_B and T_C) are marked. The *boiling point surface* is the lower (convex) surface spanned by the binary boiling point curves on the faces. Similarly, the upper (concave) *dew point surface* is spanned by the binary dew point curves found on the vertical faces. In between these two surfaces, there is a no-phase area. Below the boiling point surface, liquid mixtures are stable; above the dew point surface, vapor mixtures are stable. If we are only interested in constant temperature equilibria, sections similar to the one shown in panel (b) are enough to know, which are easy to draw in two dimensions.

The same principles can be used to construct a phase diagram of partially miscible ternary liquids. In Fig. 7.31, two pairs of components (A and C, B and C) are completely miscible, while the pair A and B is only partially miscible. The concave surface in diagram (a) shows the equilibrium temperature as a function of composition. Homogeneous liquid mixtures are outside of the surface, while the inside is a no-phase area. Diagram (b) is a section at constant temperature, where a few points indicating the equilibrium concentrations of separated A-rich and B-rich mixtures (small circles) are interconnected by conodes (or tie lines). The continuous solid line is the locus of these equilibrium concentration *node pairs*, whence it is called a *binodal curve*. In case of an overall composition lying within the binodal curve, the mixture separates into an A-rich and a B-rich phase.

Figure 7.32 shows a ternary solid–liquid T - x phase diagram with the three components forming eutectics pairwise, and partially mixing also in the solid phase. On the front face of the triangular prism, we can recognize the binary

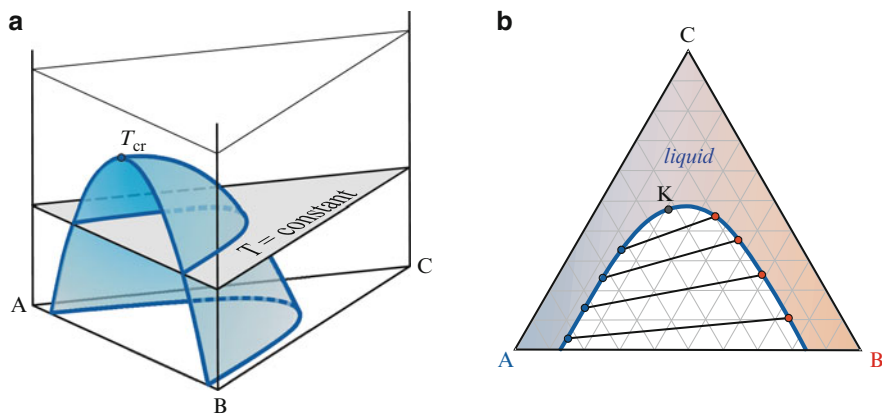

Fig. 7.31 Phase diagram of a ternary liquid with partial miscibility of components A and B, and complete miscibility of the other two pairs of components. (a) Composition is given in an equilateral triangle; temperature scale is along the vertical axis. The concave surface shows the equilibrium temperature of the separated phases as a function of composition. Homogeneous liquid mixtures are outside of the surface, while the inside is a no-phase area. The three components are completely miscible above the critical temperature T_{cr} . A constant temperature plain is also shown. (b) A constant temperature section shown in a triangular diagram. The upper shaded area is the stability range of the liquid phase; the white one is the no-phase area; point K is the critical composition (cf. Fig. 7.22). Below the critical composition, there is a phase separation. A few conodes (or tie lines) connecting the compositions of liquid phases in equilibrium are also shown. (For the sake of clarity, there are no conodes shown in the tridimensional diagram)

phase diagram A–B similar to the tin–lead mixture. The other two faces are also alike. The three “lobes” of the tridimensional *liquidus surface* (or freezing point surface) is spanned by the binary systems’ liquidus curves. As the three components mutually dissolve each other partially, we find stability ranges of solid solutions along the lateral edges of the prism. The limiting surfaces of these ranges are the *solidus surfaces* (or melting point surfaces) at temperatures where the solid is in equilibrium with a liquid mixture. At lower temperatures (below the freezing point) solid phases are in equilibrium with each other lying on the limiting surfaces, which are called *solvus surfaces*.

We can find ternary eutectics along the short-dashed curves at the intersection of the liquidus “lobes,” starting from the eutectic points of the binary mixtures on the three lateral faces of the prism, and joining in a single point in the middle of the diagram. At this point, there are four phases in equilibrium: liquid mixture, and the solid solutions α , β , and γ . According to the phase rule, the residual number of degrees of freedom at constant pressure is zero here; thus, this point occurs at a unique temperature and composition.

In the triangular diagram (b), we can see the section at the constant temperature indicated by the horizontal plane in the tridimensional diagram (a). This section is a convenient means to show the stability range of different phases at a given temperature. Solid phases are delimited by the solidus curves and the liquid phase by the

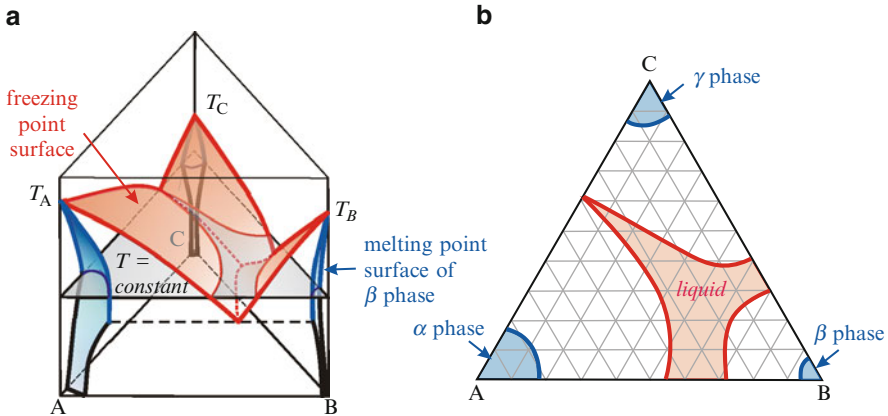

Fig. 7.32 Phase diagram of a ternary system with components of unlimited miscibility in the liquid phase and partial miscibility in the solid phase, forming ternary eutectics. **(a)** Composition is given in an equilateral triangle; temperature scale is along the vertical axis. The contiguous surface on top is the freezing point of liquid mixtures, i.e., the solid–liquid equilibrium temperature as a function of liquid composition. Surfaces close to the lateral edges below show the melting point of the corresponding solid phases above the eutectical surface, i.e., the solid–liquid equilibrium temperature as a function of solid composition. Below the eutectical surface, they mark the boundaries of stability of the solid phases. **(b)** Plot of the constant temperature section shown in panel **(a)** in a triangular diagram. Shaded areas in the corners show the stability ranges of the solid phases, while that of the liquid phase is the central shaded area. White surfaces in between are no-phase areas

liquidus curves. Between these two curves, there is a no-phase area. Similar sections are useful to characterize the ternary phase equilibrium at constant temperatures.

If we are interested in changes of the stability regions as a function of temperature, projections of the tridimensional surfaces into a triangular diagram can be constructed instead of sections. As an example, the projection of the liquidus surface of the phase diagram in Fig. 7.32a) is shown in Fig. 7.33b). Panel (a) in this figure also shows the tridimensional phase diagram along with seven curves resulting from the intersections of seven planes at different constant temperatures. The projection of these curves onto the base triangle of the prism yields the triangular diagram of panel (b).

Contour lines represent decreasing equal temperatures of freezing points from the apexes inward. We can readily follow the change of composition of the two-phase eutectics, denoted by the dashed curves (which are not equitemperature curves). These start from the eutectical points of binary mixtures E_{AB} , E_{AC} , and E_{BC} found at the edges of the triangle, and join at the composition of the three-phase eutectic E_3 . This point is unique (invariant); i.e., it has zero degrees of freedom. Similar projections of the solidus surfaces can also be constructed where we can follow the change of melting points with composition.

In case of more than three components, the visualization of a phase diagram is not an easy task. The four-component equivalent of tracing the three-component

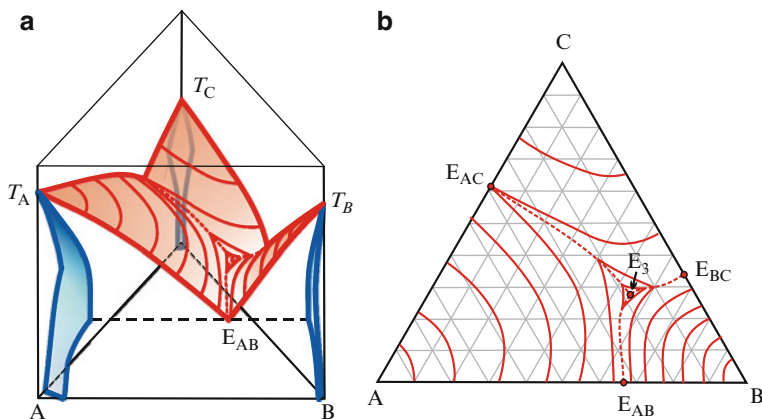

Fig. 7.33 (a) Phase diagram of a ternary system with components of unlimited miscibility in the liquid phase and partial miscibility in the solid phase, forming ternary eutectics. The contiguous surface on top is the freezing point of liquid mixtures, i.e., the solid–liquid equilibrium temperature as a function of liquid composition. (b) The projection of this surface shown as equitemperature lines (same as in the tridimensional plot) in a triangular diagram. Eutectical points of binary mixtures E_{AB} , E_{AC} and E_{BC} are found at the edges of the triangle. Dashed curves show the composition according to two-phase ternary eutectics, which join at the composition of the three-phase eutectic E_3

composition in a triangle diagram was a tetrahedron diagram. Its apexes were the pure components, while the concentration would change linearly along the heights of the tetrahedron. However, to show equilibrium temperatures (or pressures) would need a fourth dimension which is almost impossible to trace. The projection of the phase boundaries into the tetrahedron is also hopeless to show. A usual practice is, therefore, to keep the concentration of all the components but two constant, thus showing a “quasi-two-component” phase diagram, or to keep the concentration of all the components but three constant, thus showing a “quasi-three-component” phase diagram. These are in fact sections of multicomponent phase diagrams. If a practical usage of some kind of – usually two-dimensional – projections of the multidimensional surface is useful, then these projections are shown. Many multicomponent phase diagrams in the field of mineralogy or metallurgy are traced this way.

7.8 Separation of Components Based on Different Phase Diagrams

Separation of mixtures is a common task in the laboratory as well as in the chemical industry. To accomplish this task, the knowledge of phase equilibria is often useful. We will consider some examples for the separation of mixtures using the information offered by different phase diagrams.

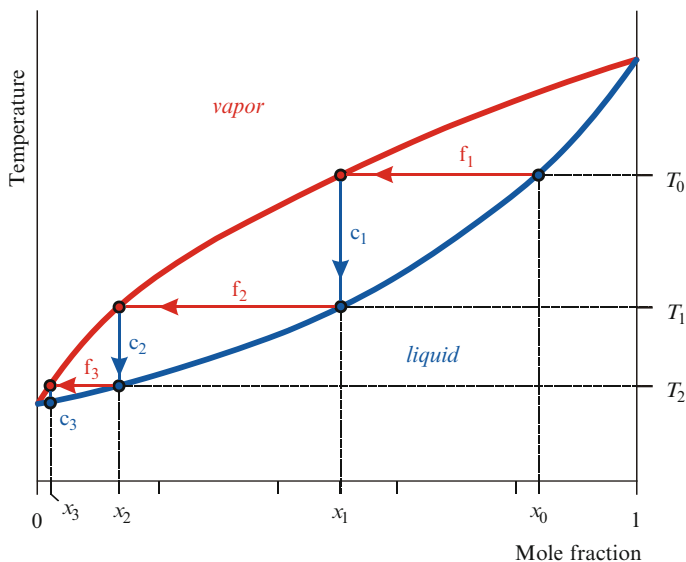

Fig. 7.34 Distillation of a nearly ideal binary mixture illustrated in a $T - x$ phase diagram

A frequently used separation method is *distillation*.¹⁹ This works best in case of an ideal (or nearly ideal) binary mixture, the vapor–liquid phase diagram of which is similar to that of Fig. 7.13. The separation of such a mixture using *fractional distillation* can be followed considering Fig. 7.34. When the liquid mixture of composition x_0 is heated to its boiling point T_0 , the composition of the emerging vapor mixture x_1 is obtained along the tie line f_1 on the dew point curve. By condensation of this vapor, we get a liquid of the same composition along the vertical line k_1 . Boiling of this liquid (at temperature T_1) leads to the emergence of a vapor mixture of composition x_2 along the tie line f_2 . By condensation of this vapor, we get the liquid mixture of the same composition along the line k_2 . Boiling this liquid and condensating its vapor (along tie line f_3 and vertical line k_3 – this latter hardly visible in the diagram) we get a liquid of composition x_3 . As we can read off from the diagram, the concentration of the more volatile (that with the lower boiling point) component 1 – x_0 is 16% before the first boiling, and it increases to 50% after the first, 86% after the second, and 98% after the third boiling and condensation. We can readily conclude that after a few further boiling and condensation cycles – the traces would not be visible on the figure anymore – we could get the more volatile component as pure as desired.

A crucial point of the above-described separation procedure is that the vapor condensed always has the equilibrium composition at the boiling point. This can be maintained if we condense only a tiny amount of the vapor – as the concentration of

¹⁹The English version of the Latin word *distillation*, which can be derived from the Latin noun *still* = drop, by adding the prefix *de-* = down from (something); meaning “dropping down”.

the more volatile component in the vapor would decrease on further boiling. One possibility for an efficient separation would be a simple *multistage distillation* when only a small amount were boiled and condensed in the first step, then new distillations were performed in a similar manner until the desired purity would be achieved – in very little quantity. However, there is a more effective method; *fractional distillation*, usually called *rectification*.²⁰ This can be achieved in a distillation column by the interchange of matter between rising vapor and falling liquid, in a *countercurrent* process.

The first industrial columns contained *plates* or *trays* arranged vertically, each of them serving as a distillation step in a multistage process. Vapor arising from the boiler of temperature T_0 at the bottom of the column arrives through a tube covered by a *bubble cap* or *bubble valve* above the first plate and condenses. Condensation keeps the temperature at the dew point T_1 of the vapor, while the released condensation heat keeps the condensed liquid boiling. The emerging vapor passes (through the tube and bubble cap or bubble valve above the first plate) to the second plate, where it condenses at its dew point T_2 . Excess liquid from the first plate flows back to the boiler through an overflow tube, ending below the liquid level to avoid the passage of vapor. Similarly, emerging vapor from the second plate passes to the third plate and condenses at temperature T_3 , while excess liquid flows down to the first plate. The process continues in every plate further upwards, and the evaporating liquid in the boiler is continuously filled up. As a result, the liquid in the boiler has a steady-state composition x_0 and boils at temperature T_0 . Composition in the first plate is x_1 and the temperature is T_1 ; in the second plate, it is x_2 and T_2 , etc. Thus, a rectifying column hosts one boiling-condensation step of Fig. 7.34 in each plate – if equilibrium is maintained, which occurs if the feeding rate of the liquid into the boiler is low. As a result, we get an enriched mixture in the more volatile component, equivalent to the product of a multistage distillation described above. If equilibrium is maintained throughout the column, the result is the same as if we made a fractional distillation of as many stages as the number of plates. Accordingly, the efficiency of a rectifying column can be characterized by the number of plates.

As the enriched mixture is continuously removed at the top of the column, a continuous feed of the liquid to be separated is also necessary. To maintain the equilibrium concentration and temperature at the plates, the flow rate within the column should be greater than the rate of feed and removal. To this purpose, the condensed liquid at the top of the column (distillate or top product) is not completely removed; part of it is reintroduced into the top plate. This part is called the *reflux*. Some part of the liquid from the boiler should also be removed; this is called the *bottom product*, which is enriched in the less volatile component. If the purpose of rectification is only the separation of the pure more volatile product, fresh mixture is feeded into a lower plate near the boiler. If the less volatile component is also needed, feed is introduced near the middle of the column.

²⁰Rectification is derived from the Latin adjective *rectus* = right, or simple. It refers to the isolation of the simple (“right”) material from the composite mixture.

Equilibrium within the plates below the feed occur at compositions and temperatures which can be traced as perpendicular lines between the boiling point and dew point curves on the right of the phase diagram, toward increasing temperatures. This downward flow of the liquid results in gradual enrichment from plate to plate of the less volatile component.

The construction of valves and overflow tubes is rather expensive and their setup cannot be changed. A widely used alternative is a *packed column*: a hollow pipe filled with large-surface packing. The packing can consist of small pieces of tubes, beads, rings, or other objects that provide a great surface for liquid–vapor contact and control the flux of downstream liquid and upstream vapor so that a near-equilibrium state is achieved throughout the column at the actual top product and bottom product removal rate. The separation efficiency of a packed column is given as the *number of theoretical plates*, referring to an equivalent traditional column with the same number of discrete stages. The efficiency of the packing is determined as the *height equivalent to one theoretical plate* (HETP) which is the packing height equivalent to a theoretical equilibrium stage – a horizontal and a subsequent vertical line in Fig. 7.34. (Smaller HETP means greater separation efficiency.)

It is clear from Fig. 7.34 and the above discussion that the vapor is always enriched in the *more volatile* component; thus, separation by distillation is limited in case of azeotropes. Components of a maximum-boiling azeotrope can be completely separated by distillation, while in case of a minimum-boiling azeotrope; only the azeotrope mixture having the minimal boiling point can be separated. In either case, mixtures having exactly the azeotrope composition cannot be separated at all by distillation. (A common example is a 96 volume % ethanol–water mixture having a minimal boiling point of 78.15 °C.) One possibility to separate binary azeotropes is to prepare a ternary azeotrope in which the azeotrope concentration of the component to be enriched is higher than in the binary azeotrope. For example, rectification of the ternary azeotrope benzene–ethanol–water leads to almost pure ethanol. As the azeotrope concentration is pressure-dependent, a rectified azeotrope distilled at atmospheric pressure might be considerably enriched at another pressure. In case of the ethanol–water mixture, there is no azeotrope concentration below the pressure of 11.5 Pa.

From a thermodynamic point of view, solid–liquid equilibrium can be used in a similar manner as distillation to separate components if the liquid and solid mixtures are nearly ideal; i.e., neither the freezing-point nor the melting-point curve exhibits an extremum. By considering the phase diagram in Fig. 7.18, we can see that the concentration of the lower melting point component in the melted mixture ($x_{1,l}$) is greater than in the solid ($x_{1,s}$) in equilibrium with this mixture. Freezing a small quantity of the melt, the higher melting point component is enriched in the crystals formed. Melting the separated crystals and freezing a small portion of the melt again, further enrichment occurs. After a finite number of such *recrystallizations* we can get an almost pure component.

There exists a continuous version of this multistage recrystallization called *zone melting*. The liquid metal is filled in a thin tube whose material does not mix with the metal (neither with its impurities) and melts at higher temperature than the

metal. The tube is fitted inside a heater which heats only a small disc-like portion at one end of the tube. The metal inside melts and impurities having a lower melting point than the metal itself get enriched in the melt. The heater is slowly swept toward the other end of the tube. At the cooling end of the melt from where the heater is leaving, solid crystals in equilibrium with the melt freeze out, while at the front where the heater moves on, solid metal is melting (along with impurities). While the heater is sweeping along the tube, impurities “accumulate” in the melted zone as they freeze out in a lower concentration behind the zone. At the end of the tube, the melt is completely frozen and the disc containing a high concentration of impurities is detached from the metal rod. The procedure can be repeated several times to get purer and purer metal. Instead of sweeping several times with the same heater (usually back and forth), several heaters can be swept one after another at the same time so that the metal would refreeze between them. This latter technique obviously results in multiple recrystallizations in a much shorter time. Zone melting to remove impurities can be applied also in the case of eutectic phase diagrams of the types shown in Figs. 7.24 and 7.25, as well as in cases of the phase diagrams shown in Fig. 7.28, for in all these cases “impurity” B is always enriched near compositions of the pure component A.

Recrystallization is an efficient means of separation if the components do not mix in the solid phase, as for example in case of a phase diagram of Fig. 7.24. In this case, one of the pure components crystallizes, depending on the actual composition. Common examples are aqueous salt solutions, resulting in pure salt crystals when cooled. However, at exactly the eutectic composition, there is no separation of the components. When cooling mixtures of other compositions, their remaining liquid also reaches the eutectic composition sooner or later, when a mixture crystal begins to freeze out. Recrystallization should be halted before this event.

Immiscible liquids also offer an alternative for separation. A common separation method based on this kind of phase equilibrium is *steam distillation*. It is mostly used to separate mixtures of organic compounds immiscible with water, e.g., fragrances or spices (essential oils) extracted from natural raw material using oils. To boil the oil containing the extract would require high temperatures where the dissolved compound would decompose, which is avoided by steam distillation. On the other hand, the low-temperature steam distillation is also simpler and less energy-consuming. Let us consider the water-insoluble oily phase a binary mixture, e.g., wax distributed on glass plates containing an essential oil extracted from flowers placed onto the wax layer. The wax component has a negligibly low vapor pressure even at the boiling point of water, compared to the vapor pressure p_i of the essential oil and p_{water}^* of pure water. Therefore, the equilibrium vapor pressure over the immiscible water and the oily phase is the sum of these two pressures:

$$P = p_{\text{water}}^* + p_i. \quad (7.131)$$

This will be the overall vapor pressure, independently of the ratio of the two phases, until the liquids are stirred to have a great enough surface where they can

evaporate. As we can see, the boiling point of the stirred mixture is *lower* than that of the pure water, for it is not necessary that the vapor pressure of water reaches the atmospheric pressure P to boil; it is enough that it reaches the lower value of $P - p_i$. Consequently, both stirring and boiling can be maintained by introducing water vapor into the two-phase liquid through a tube from an external boiler. The emerging vapor mixture is condensed, and the distillate consists of essential oil and pure water in separated phases, their molar ratio being equal to the ratio of the vapor pressures. (In case of – usually small – miscibility, water will contain some essential oil and the essential oil will also contain a small amount of water.) The quantity of the essential oil distilled this way can be obtained from the equation

$$n_i = n_{\text{water}} \frac{p_i}{p_{\text{water}}^*}. \quad (7.132)$$

Steam distillation is widely applied to the purification of temperature-sensitive organic compounds. By substituting the mass of the compounds divided by their molar mass into the above equation, we can express the mass yield of the organic component:

$$m_i = m_{\text{water}} \frac{M_i}{M_{\text{water}}} \frac{p_i}{p_{\text{water}}^*}. \quad (7.133)$$

As we can see, the small molar mass of water increases the amount of greater molar mass organic compounds, thus compensating for an eventual low partial pressure.

Another separation method based on immiscibility of liquids is *liquid–liquid extraction*.²¹ An example is the separation of two completely miscible liquids of which one component is miscible with a third liquid, but the other component is only partially miscible. The separation procedure can be demonstrated in Fig. 7.35.

Fig. 7.35 Extraction of component B from a binary mixture A–B using solvent C. K: initial binary mixture; M: overall composition of the ternary mixture after having added component C, which separates into two phases of compositions R and E. After complete evaporation of component C from both phases, the extract E' and the raffinate R' are obtained

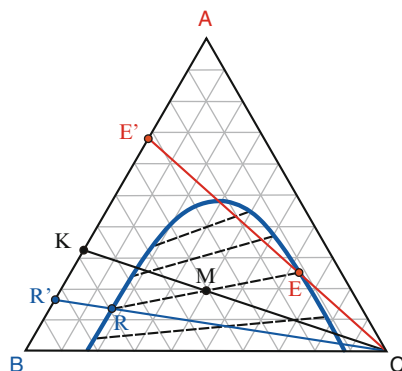

²¹This word originates from the Latin verb *extraho* = draw out. The English verb is extract.

The *solvent* C is added to the binary mixture of composition K in a quantity that results in the *mixture* composition M. This ternary mixture of the overall composition M separates along the tie line passing through M into two phases at the intersection of the tie line and the equilibrium curve of the miscibility boundaries. The phase of composition E (*extract*) and that of composition R (*raffinate*) can physically be separated in a *settling vessel* due to their density difference. By evaporating the solvent C from both the extract and the raffinate, we get the binary extract E' and the raffinate R'. (Note that the molar ratio of components A and B is constant along the lines passing through the apex C.) The extract can further be enriched in component A by subsequent distillation of the binary extract.

Though extraction can also be carried out in a multi-stage extractor, increasing the rate of enrichment, but a pure component A cannot usually be obtained; it is typically provided by a subsequent distillation. Extraction is a good choice if the binary mixture is an azeotrope and the mixture of composition K cannot be separated by distillation, but the extract E' can be. It is also advantageous as a preenrichment method if energy consumption of the distillation is markedly higher than that of the extraction.

The efficiency of extraction can be characterized by the *partition ratio* (also called *distribution constant*), which can be derived from the thermodynamic characterization of the partition equilibrium. According to this, the chemical potential of component A should be the same in equilibrium in both phases of compositions R and E in Fig. 7.35. A formal statement of this condition is:

$$\mu_B^{\ominus} + RT \ln \gamma_{x,B} x_B = \mu_C^{\ominus} + RT \ln \gamma_{x,C} x_C. \quad (7.134)$$

In this equation, subscript B denotes the phase richer in component B, and subscript C the phase richer in component C. By rearranging, we get the ratio of the activities of component A in the two phases:

$$\frac{a_C}{a_B} = \frac{\gamma_{x,C} x_C}{\gamma_{x,B} x_B} = e^{\frac{\mu_B^{\ominus} - \mu_C^{\ominus}}{RT}}. \quad (7.135)$$

As neither μ_B^{\ominus} nor μ_C^{\ominus} depends on the composition, the exponential is independent of concentration. Consequently, the distribution constant

$$K_D = \frac{a_C}{a_B} = \frac{x_C}{x_B} \frac{\gamma_{x,C}}{\gamma_{x,B}}, \quad (7.136)$$

is also independent of the composition. If both x_B and x_C are small enough that both liquids can be considered as ideal mixtures concerning component A, the ratio $\gamma_{x,C}/\gamma_{x,B}$ can be approximated as unit; thus, K_D gives the ratio of concentrations. (The mixture B–C is of course *not* ideal, as the two components do not mix.)

There exist solvents used for extraction which do not mix in a measurable quantity with the solvent of the component to be extracted from a binary mixture, but the solute has a high solubility in them. This is the case if iodine is distributed between water and chloroform; iodine dissolves well in the moderately polar chloroform but rather purely in water. The partition ratio between chloroform and water is about 130, so that iodine can be efficiently separated from its aqueous solution by using a *separation funnel*. (A separation funnel is used in the laboratory practice, which is well shaken after the two phases are filled in. Equilibrium is achieved quickly by shaking, and the two phases separate quickly if the funnel stands still.) In addition to extraction, many chromatographic techniques are also based on the distribution of components between two immiscible phases.

Problems

1. The equilibrium vapor pressure of a single component liquid at 300 K was found to be 0.2 bar. The heat of vaporization of the liquid is 40 kJ/mol. Assume the vapor to be an ideal gas, its density to be much less than that of the liquid. Estimate the temperature at which the equilibrium vapor pressure is doubled.

Solution: The logarithmic form of (7.45) – the solution of the Clausius–Clapeyron equation – can be used in the following form:

$$\ln \frac{P_1}{P_2} = \frac{\Delta_{\text{vap}} h}{R} \left(\frac{1}{T_2} - \frac{1}{T_1} \right).$$

Solution of the equation inserting $P_1/P_2 = 2$ yields 313.55 K at which the vapor pressure is doubled.

2. The triple point of methanol is at $T = 175.610$ K and $p = 0.0002$ Pa. Sketch the phase diagram at the vicinity of the triple point, using the following data: $\Delta_{\text{vap}} h = 35.2$ kJ/mol, $\Delta_{\text{fus}} h = 3.173$ kJ/mol, $\rho_l = 0.7918$ g/cm³ and $\rho_s = 0.7802$ g/cm³. Suppose the shape of the coexistence curves to be linear within the range of the sketch and the vapor as an ideal gas.

Solution: The slope of each line is given by the Clapeyron equation (7.38) as

$$\frac{dP}{dT} = \frac{\Delta_{\alpha}^{\beta} h}{T \Delta_{\alpha}^{\beta} v}.$$

The missing heat of sublimation can be calculated based on the state function property of enthalpy as $\Delta_{\text{sub}} h = \Delta_{\text{vap}} h + \Delta_{\text{fus}} h$. Molar volumes of solid and liquid methanol can be calculated from the densities as $v = M/\rho$, and the missing molar volume from the ideal gas equation of state. Using these quantities, the slopes of the three coexistence curves are the following:

$$v/l : 27.45 \mu\text{Pa/K}; \quad v/s : 29.93 \mu\text{Pa/K}; \quad l/s : -30.07 \text{kPa/K}.$$

Using these quantities as the slopes of linear portions of coexistence curves, the sketch looks like the one below. Note that the solid/liquid coexistence line looks completely vertical at a scale (shown) where the vapor/liquid and vapor/solid lines

are not looking completely horizontal. However, the solid/liquid coexistence line is tilted to the left – similarly to that of water.

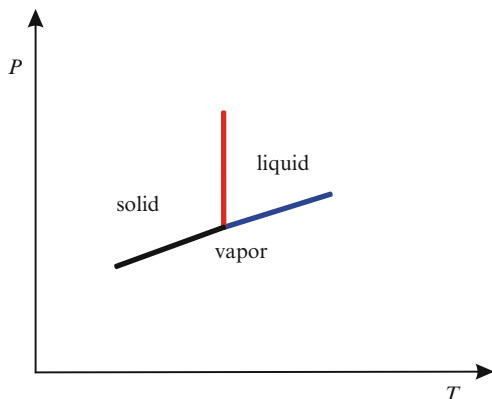

3. The boiling temperature of a binary solution of A and B of concentration $x_A = 0.45$ is 100°C at 1.016 atm. At this temperature, the vapor pressures of pure A and B are 120.1 and 89.0 kPa, respectively. Prove that the solution is ideal and calculate the composition of the vapor when boiling begins.

Solution: The equilibrium partial pressures of the components of an ideal mixture can be calculated using Raoult's law:

$$P_{\text{tot}} = x_A p_A^* + (1 - x_A) p_B^* = 102.955 \text{ kPa.}$$

As $1.016 \text{ atm} = 102.9462 \text{ kPa}$, the solution can be considered as ideal. The composition of the vapor is easy to determine from the above data using the equations for the mole fractions in the vapor

$$y_A = \frac{p_A}{p_A + p_B} \quad \text{and} \quad y_B = \frac{p_B}{p_A + p_B}.$$

After substitution, we get $x_A = 0.52$ and $x_B = 0.48$.

4. The melting points of the pure compounds A and B are 120 and 150 K, respectively. The two substances undergo a chemical reaction to form a solid compound AB:

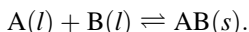

The melting point of the compound AB is 140 K. The system has two eutectic points at atmospheric pressure: one at the mole fraction 0.25 of component A (110 K) and another at 0.80 (90 K). Sketch the phase diagram of this system, and another diagram of the cooling curves at the three mole fraction values 0.25, 0.50, and 0.75 of A. Mark the temperatures given in the text and assign phases. Explain the shapes of the cooling curves.

Solution: The sketch of the phase diagram according to the data given looks like the one below.

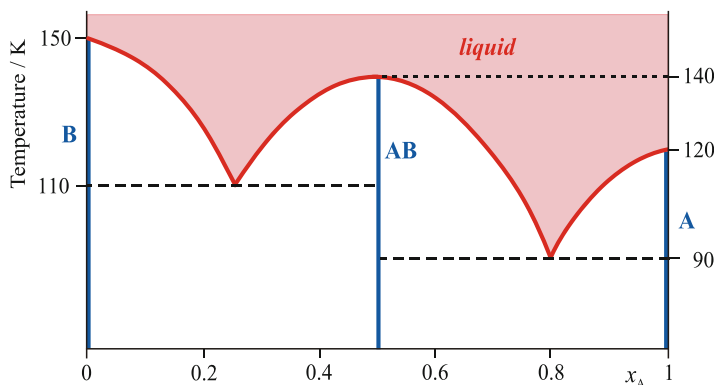

Stable phases are liquid (shaded upper area), pure solid B (left edge below 150 K), pure solid A (right edge below 120 K), and the solid compound AB (vertical line at $x_A = 0.5$, below 140 K). Eutectical lines at 90 K and 110 K are marked dashed.

Cooling curves at the given three mole fractions are sketched below.

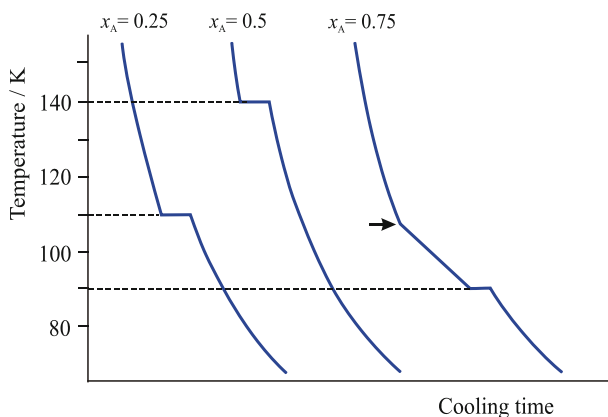

At $x_A = 0.25$, there is a eutectic point. Thus, the liquid cools down until the eutectic temperature of 110 K, where it solidifies. The cooling rate slightly decreases with decreasing melt temperature until 110 K, but the temperature remains constant at this value during solidification. Once the entire system becomes a solid eutectic microcrystalline mixture, cooling down is continued again with a decreasing cooling rate.

At $x_A = 0.5$, there is a reaction forming the compound AB at solidification. Thus, the liquid cools down until the solidification temperature of the compound at 140 K, where it solidifies, while the temperature remains constant. When the entire system becomes the solid compound AB, cooling down is continued again with a decreasing cooling rate.

At $x_A = 0.75$, the liquid begins to solidify at approximately 107 K (as it can be read from the phase diagram); thus, the cooling rate is abruptly slowed down due to the release of the heat of freezing. (The breakpoint is marked by an arrow. The solid formed is the compound AB). During this freezeout, the concentration continuously changes toward the eutectic concentration of $x_A = 0.8$, where the eutectic microcrystals are formed at the constant temperature 90 K, again without cooling. As soon as the remaining liquid mixture becomes a solid eutectic microcrystalline mixture, cooling down is continued again with a decreasing cooling rate.

Note that this cooling behavior makes it possible to experimentally determine the phase diagram from cooling curves. A congruent freezing (where the composition of the solid formed is identical to the composition of the liquid) is always accompanied by a horizontal (constant temperature) portion of the cooling curve, while an abrupt change of the slope of the cooling curve (but with continuing cooldown) indicates the onset of formation of a solid phase when composition changes continuously. By determining the constant temperatures and the breakpoint temperatures at different mixture concentrations, we can construct the phase diagram.

Further Reading

- Atkins P, de Paula J (2009) *Physical chemistry*, 9th edn. Oxford University Press, Oxford
- Balzhiser RE, Samuels MR, Eliassen JD (1972) *Chemical engineering thermodynamics – the study of energy, entropy, and equilibrium*. Prentice-Hall, Englewood Cliffs, NJ
- Denbigh KG (1981) *The principles of chemical equilibrium*, 4th edn. Cambridge University Press, Cambridge
- Guggenheim EA (1985) *Thermodynamics: an advanced treatment for chemists and physicists*, 7th edn. North Holland, Amsterdam
- Guggenheim EA (1952) *Mixtures*. Clarendon, Oxford
- IUPAC (2007) *Quantities, units and symbols in physical chemistry*, 3rd edn. RSC Publishing, Cambridge
- Silbey LJ, Alberty RA, Mounji GB (2004) *Physical chemistry*, 4th edn. Wiley, New York

Chapter 8

Equilibria of Chemical Reactions

In this chapter, we remove the nonreactivity constraint imposed on simple systems and allow for chemical reactions to occur. Obviously, this is the most interesting application for chemists. Although the expression “chemical interaction” has been mentioned several times in previous chapters, it has always referred to the spatial displacement of chemical species; they could leave or enter the system (open systems), or pass from one phase to another (phase equilibria). This chapter deals with the possibility of “real” chemical reactions, when the amount of chemical species can change without spatial displacement. Nevertheless, reacting species can be not only within the same homogeneous phase, but also in different phases.

Chemical reactions are usually described by *stoichiometric equations*.¹ In thermodynamics, stoichiometric equations are written in a special form, so that the equation is set equal to zero. The advantage of this form is that reactants and products (species on the left-hand side and on the right-hand side in the more common equation) can be treated the same way, thus simplifying the mathematical treatment. The general stoichiometric equation of this form can be written as:

$$\sum_{i=1}^R v_i A_i = 0. \quad (8.1)$$

The symbol A_i denotes the stoichiometric formula of the species i and v_i is the *stoichiometric number* of this species. The index i runs over all the *reacting species* whose number is R . (Components that do not react – like an inert solvent – would have a zero stoichiometric number, thus it is superfluous to include them in the sum.) As an example, let us write one of the possible equations of the formation of ammonia:

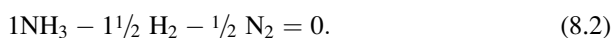

¹The word is coined from the Greek nouns *στοιχειον* = element and *μετρον* = measure, meaning the quantity of elements in a compound or in a reaction.

In this equation $A_1 = \text{NH}_3$, $A_2 = \text{H}_2$, $A_3 = \text{N}_2$, $v_1 = 1$, $v_2 = -1/2$ and $v_3 = -1/2$. As explicitly written chemical equations are normally not written in this form, we frequently keep the familiar form



but still consider the stoichiometric number v_i of the reactants as *negative* and that of the products *positive*, in accordance with the form of (8.1). We shall use this convention in the rest of this book.

8.1 Condition of a Chemical Equilibrium at Constant Temperature and Pressure

Let us consider a reacting thermodynamic system at constant pressure and temperature. The condition of equilibrium in this case is the minimum of the Gibbs potential function $G(T, P, \mathbf{n})$ – as listed in Table 4.1. At the minimum of the function, its first differential is zero:

$$dG = -SdT + VdP + \sum_{i=1}^K \mu_i dn_i = 0. \quad (8.4)$$

As the temperature T and the pressure P , as well as the amounts n_i of the $K - R$ nonreacting species are constant, the condition of chemical equilibrium simplifies to:

$$\sum_{i=1}^R \mu_i dn_i = 0. \quad (8.5)$$

Let us examine this condition in case of a general chemical reaction:

$$\sum_{i=1}^R v_i A_i = 0. \quad (8.6)$$

The chemical potential of each component A_i can be written as:

$$\mu_i = \mu_i^\ominus + RT \ln a_i. \quad (8.7)$$

Substituting this formula into (8.5), we get:

$$\sum_{i=1}^R (\mu_i^\ominus + RT \ln a_i) dn_i = 0. \quad (8.8)$$

As we can see, there are R different increments dn_i in this formula. However, we know that they cannot be independent; they are all connected by the stoichiometric equation, thus one single variable is enough to characterize the extent of the change

of amounts of components according to the given stoichiometric equation. Mathematically, this can be formulated the following way. Let us denote the initial concentration (prior to the start of the reaction) for each component by $n_{i,0}$, and express its instantaneous concentration during the reaction with the help of a variable ξ (Greek lowercase “ksi”) depending on the progress of the reaction:

$$n_i = n_{i,0} + v_i \xi. \quad (8.9)$$

The variable ξ is called the *extent of reaction*. From the above definition, it is clear that ξ is an extensive quantity, and its unit is mole. It can be interpreted as the number of moles of the stoichiometric equation that has been converted from reactants to products. To formulate the condition of equilibrium, we need the increments n_i what we can get by differentiating (8.9):

$$dn_i = v_i d\xi. \quad (8.10)$$

Substituting this in (8.8), we obtain:

$$\sum_{i=1}^R (\mu_i^\ominus + RT \ln a_i) v_i d\xi = 0. \quad (8.11)$$

The increment $d\xi$ does not depend on the index i , thus it can be factored out from the sum. As $d\xi$ can be chosen arbitrarily, the other factor of the product should be zero. Accordingly, the condition of equilibrium is simplified to:

$$\sum_{i=1}^R v_i (\mu_i^\ominus + RT \ln a_i) = 0. \quad (8.12)$$

An interesting property of this condition is revealed if we substitute here the chemical potential μ_i according to (8.7):

$$\sum_{i=1}^R v_i \mu_i = 0. \quad (8.13)$$

As we can see, the condition of chemical equilibrium has the same form as the stoichiometric equation (8.6), with the chemical potential μ_i in place of the formula A_i of the respective species.

Although (8.12) is appropriate to determine the equilibrium state, in common practice it is not this equation which is used, but a different form. To obtain this usual form, let us rearrange the equation and introduce some new notation. The rearranged equation we start with is the following:

$$\sum_{i=1}^R v_i \mu_i^\ominus = - \sum_{i=1}^R v_i RT \ln a_i. \quad (8.14)$$

Note that the standard chemical potentials μ_i^\ominus on the left-hand side are identical to the partial molar Gibbs potentials G_i^\ominus that can be assigned to the standard states. Accordingly, we can write:

$$\sum_{i=1}^R v_i \mu_i^\ominus = \sum_{i=1}^R v_i G_i^\ominus = \Delta_r G^\ominus. \quad (8.15)$$

The quantity $\Delta_r G^\ominus$ thus defined is called the *standard reaction Gibbs potential*. (The result of the summation is denoted by the Greek letter Δ used for difference, as there are necessarily also negative stoichiometric numbers, thus this quantity is the difference of the standard Gibbs potential of the products and that of the reactants.) The product RT in (8.14) can be factored out from the sum, while the factor v_i of the logarithms can be written as the power of the arguments. Finally, the sum of logarithms obtained this way can be written as the logarithm of the product of the arguments, applying the usual notation Π (Greek upper case “pi”) for the product. Thus, we get the result:

$$\sum_{i=1}^R v_i RT \ln a_i = RT \sum_{i=1}^R \ln (a_i)^{v_i} = RT \ln \prod_{i=1}^R (a_i)^{v_i}. \quad (8.16)$$

Using this result, we can rewrite (8.14) in the following form:

$$\Delta_r G^\ominus = -RT \ln \prod_{i=1}^R (a_i)^{v_i}. \quad (8.17)$$

The standard reaction Gibbs potential $\Delta_r G^\ominus$ on the left-hand side does not depend on the composition, thus the product on the right-hand side is also composition independent. Consequently, the equilibrium condition can be formulated also with this product containing the *equilibrium activities* a_i :

$$K_a = \prod_{i=1}^R (a_i)^{v_i}. \quad (8.18)$$

The quantity thus defined is called the *equilibrium constant*, which is independent of the composition. The above result is commonly expressed in the form

$$-\Delta_r G^\ominus = RT \ln K_a, \quad (8.19)$$

though the equivalent expression

$$K_a = e^{-\frac{\Delta_r G^\ominus}{RT}}. \quad (8.20)$$

is more straightforward to calculate the equilibrium constant.

Equations (8.19) and (8.20) have a wide range of application. If we know the equilibrium constant K_a and the dependence on composition of the activity of reactive species, we can calculate the equilibrium composition of the mixture when starting from any initial composition. The equilibrium constant can be determined with the help of (8.18) by measuring the equilibrium concentrations and knowing the respective activity coefficients. It can also be calculated from thermodynamic data. For this calculation, we only need to know the standard chemical potentials of the reactive species, according to (8.15) and (8.20). The calculation of the standard chemical potentials is discussed in Sect. 8.3.

8.1.1 Relation of the Equilibrium Constant and the Stoichiometric Equation

It is important to know some limitations of the application of the equilibrium constant. The most important limitation is that it *does not refer to a reaction, but to an actual form of the stoichiometric equation*. While demonstrating this property, we also show the application for an actual chemical reaction. Let us consider the formation of ammonia from its elements already mentioned in the introduction of this chapter. Consider the stoichiometric equation in the form of (8.3):



The equilibrium constant and the standard reaction Gibbs potential can be given as follows:

$$K_{a,1} = \frac{a_{\text{NH}_3}}{(a_{\text{H}_2})^{3/2} (a_{\text{N}_2})^{1/2}} \quad \Delta_{r,1} G^\ominus = \mu_{\text{NH}_3}^\ominus - \frac{3}{2} \mu_{\text{H}_2}^\ominus - \frac{1}{2} \mu_{\text{N}_2}^\ominus. \quad (8.22)$$

Consider next another stoichiometric equation for the same reaction, which does not contain fractional stoichiometric numbers but whole numbers only:



The equilibrium constant and the standard reaction Gibbs potential for this reaction can be given as:

$$K_{a,2} = \frac{(a_{\text{NH}_3})^2}{(a_{\text{H}_2})^3 a_{\text{N}_2}} \quad \Delta_{r,2} G^\ominus = 2\mu_{\text{NH}_3}^\ominus - 3\mu_{\text{H}_2}^\ominus - \mu_{\text{N}_2}^\ominus. \quad (8.24)$$

Comparing these with the previous quantities, we can state that $\Delta_{r,2} G^\ominus$ for reaction (8.23) is twice greater than $\Delta_{r,1} G^\ominus$ for reaction (8.21) – as we can expect. The two equilibrium constants are not identical either; $K_{a,2}$ is the square of $K_{a,1}$.

We can conclude from this example what has been already stated before; the equilibrium constant always characterizes the *stoichiometric equation*, not the *reaction itself*. We have also seen that, while the standard reaction Gibbs potential is *proportional* to the stoichiometric numbers in the equation, the equilibrium constant changes *exponentially*.

Note that the *direction* of the reaction also has a consequence on the value of the equilibrium constant. Obviously, if we would reverse the direction of the reactions in the stoichiometric equations (i.e., write the equations for the decomposition of ammonia), the standard reaction Gibbs potential would change sign, while the equilibrium constant would become the reciprocal of the original value.

There are often many simultaneous chemical reactions taking place in reactive mixtures (including those in living organisms), thus it is important to be able to describe simultaneous equilibria. In principle, this task is not more complicated than in case of a single reaction; for every reaction, the condition imposed by the corresponding equilibrium constant should hold. The concentrations of the common components in different reactions should, of course, be the same within the same phase, and the conservation of atoms (or amounts of elements) should always be fulfilled, as usually when writing stoichiometric equations. However, it is easy to find out that to write the condition of a simultaneous chemical equilibrium, only *independent reactions* should be taken into account.

A reaction is independent if it cannot be constructed from other reactions taking place by addition or subtraction (i.e., by *linear combinations*). Was it possible to construct it this way, its standard reaction Gibbs potential $\Delta_r G^\ominus$ could also be calculated by additions and subtractions from other reactions' standard Gibbs potentials, while its equilibrium constant K_a could be calculated by multiplications and divisions. Thus, the reaction would not impose additional conditions for the equilibrium. In case of a few simple reactions, it is easy to find the number of independent reactions by inspection of the stoichiometric equations. However, this method becomes quite hopeless to apply if there are many reactions with common species in the system. In this case, the property that independent reactions are *linearly independent* offers the possibility to use standard algebraic methods to find their number. This can be done by determining the rank of the *stoichiometric matrix* of the reactions. (The columns of the stoichiometric matrix display the atoms of components, while its rows the components themselves. Elements of the rows express the number of the atoms corresponding to the actual column in the component corresponding to the actual row.) Independent reactions to take into account when imposing equilibrium conditions can usually be chosen several different ways. The only condition to choose them is that they should be independent of each other.

8.1.2 Affinity: The Driving Force of Chemical Reactions

The standard reaction Gibbs potential not only plays a determining role concerning the equilibrium but it is also a determining factor concerning chemical changes.

To demonstrate this, let us recall the differential of the Gibbs potential according to (8.4), but substitute the expression for dn_i from (8.10):

$$dG = -SdT + VdP + \left(\sum_{i=1}^R v_i \mu_i \right) d\xi + \sum_{i=R+1}^K \mu_i dn_i = 0. \quad (8.25)$$

We have also rearranged terms so that the sum describing the change of the amounts of the R reacting species is separated from that of the nonreacting $K - R$ species. We know that the coefficients of the increments in the total differential are the partial derivatives of the G function with respect to the same variables as the increment. Consequently, the partial derivative of G with respect to ξ is the sum preceding the increment $d\xi$, that is:

$$\left(\frac{\partial G}{\partial \xi} \right)_{T, P, n_j > R} = \sum_{i=1}^R v_i \mu_i = \sum_{i=1}^R v_i G_i = \Delta_r G. \quad (8.26)$$

Comparing this result with (8.5), we can state that the condition of chemical equilibrium can also be written in the alternative form

$$\Delta_r G = \left(\frac{\partial G}{\partial \xi} \right)_{T, P, n_j > R} = 0. \quad (8.27)$$

Obviously, this form also expresses the fact that the reaction proceeds until a state is achieved where the Gibbs potential function has an extremum. In a stable equilibrium, it should be a minimum. Thus, we expect that the function should be *convex* as a function of the extent of reaction, which also means that, in a spontaneous reaction, the function should decrease. Consequently, the derivative $\left(\frac{\partial G}{\partial \xi} \right)_{T, P, n_j > R}$ is negative for values of ξ inferior to the equilibrium value and positive for those superior to the equilibrium value. (Note that it is negative for the reverse reaction, which actually takes place while approaching equilibrium from above the equilibrium state.) The absolute value of the derivative is monotonically decreasing as the reaction proceeds towards equilibrium and attains zero there. Due to this behavior, the quantity $-\left(\frac{\partial G}{\partial \xi} \right)_{T, P, n_j > R}$ can be considered as the measure in Gibbs potential of the distance from the equilibrium state, indicating the spontaneity of the reaction taking place from an initial state. In the early times of chemistry (the age of alchemy), the tendency of substances to react was called *affinity*, literally meaning a “relation by marriage”. That was the reason why de Donder named the quantity $-\left(\frac{\partial G}{\partial \xi} \right)_{T, P, n_j > R}$ affinity, which is frequently used in thermodynamics. Thus, this expression in use for several centuries has been exactly defined and can also be measured. Indeed, we can understand the thermodynamic background of chemical reactions by examining the Gibbs potential of the reacting mixture.

To demonstrate this, let us discuss Fig. 8.1. The diagram shows the Gibbs potential of a gaseous mixture as a function of the extent of reaction ξ . Initially (at $\xi = 0$), the mixture consists of $n_{\text{H}_2} = 1,5$ mol, $n_{\text{N}_2} = 0,5$ mol and $n_{\text{NH}_3} = 0$ mol. Obviously, if the reaction proceeds to completion (at $\xi = 1$), the mixture contains only 1 mol ammonia, and hydrogen and nitrogen are completely consumed. Using (8.9), we can write the actual composition of the mixture as a function of ξ :

$$n_{\text{H}_2} = 1.5 - 1.5 \xi \quad n_{\text{N}_2} = 0.5 - 0.5 \xi \quad n_{\text{NH}_3} = \xi. \quad (8.28)$$

The total amount of species is the sum of the amounts of the three components, $2 - \xi$ mol, thus the mole fraction of the components is given in the following form:

$$x_{\text{H}_2} = \frac{1.5 - 1.5 \xi}{2 - \xi} \quad x_{\text{N}_2} = \frac{0.5 - 0.5 \xi}{2 - \xi} \quad x_{\text{NH}_3} = \frac{\xi}{2 - \xi}. \quad (8.29)$$

Suppose that the reaction mixture behaves as an ideal mixture, thus we can apply the summation

$$G = \sum_{i=1}^R n_i \mu_i = \sum_{i=1}^R n_i (\mu_i^\ominus + RT \ln x_i) \quad (8.30)$$

for the actual mixture:

$$G = n_{\text{H}_2} \mu_{\text{H}_2}^\ominus + n_{\text{N}_2} \mu_{\text{N}_2}^\ominus + n_{\text{NH}_3} \mu_{\text{NH}_3}^\ominus + RT(n_{\text{H}_2} \ln x_{\text{H}_2} + n_{\text{N}_2} \ln x_{\text{N}_2} + n_{\text{NH}_3} \ln x_{\text{NH}_3}). \quad (8.31)$$

Figure 8.1 shows the function calculated using the above equation at the temperature of 500 K (226.85°C) and pressure of 1 bar (10^5 Pa). The standard chemical potentials of pure nitrogen and hydrogen are zero; that of pure ammonia is $4.800 \text{ kJ mol}^{-1}$; RT at this temperature is $4.157 \text{ kJ mol}^{-1}$. The equilibrium at this temperature is shifted towards the reactants.

Examining this diagram, we can have an insight into the thermodynamic background of why many reactions do not proceed until completion. Its origin is basically the fact that the Gibbs potential can decrease due to the mixing of the components of the reaction. This decrease is more important if there are more components. As we can see, this decrease already happens when mixing the reactants (1.5 mol hydrogen and 0.5 mol nitrogen in this case). This has the consequence that the Gibbs potential of the reacting mixture does not start from the sum of the standard Gibbs potentials of the reactants (zero in this case) but from the Gibbs potential of mixing that can be calculated using (8.31); in this case, from $-4.675 \text{ kJ mol}^{-1}$. If mixing would have been avoided before, as well as during the reaction (hydrogen and nitrogen were in separate phases and ammonia formed during the reaction in a third phase), the Gibbs potential of the three-phase

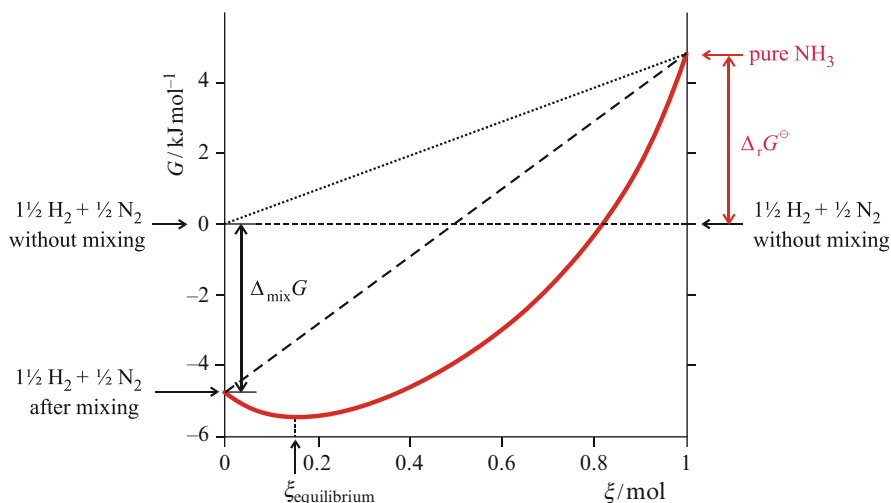

Fig. 8.1 Gibbs potential as a function of the extent of reaction ξ at the temperature of 500 K (226.85°C) and a pressure of 1 bar for the reaction $1/2 \text{ H}_2 + 1/2 \text{ N}_2 = \text{NH}_3$ in a mixture, where the initial state contains only $1/2$ mol H_2 and $1/2$ mol N_2 without any NH_3

reacting system would change along the dotted line in the diagram. If reactants would have been allowed to mix but ammonia formed during the reaction would be accumulating in a separate phase, the Gibbs potential of the two-phase reacting system would change along the dashed line. As we can see from the diagram, in case of the single-phase (homogeneous) reacting mixture, the Gibbs potential of mixing (of H_2 and $1/2 \text{ N}_2$) is already present in the system, and the contribution due to mixing of the product is added during the reaction. This change is demonstrated by the thick solid curve, which shows the Gibbs potential of the reacting homogeneous mixture. The right-hand side of the diagram also shows the contribution of the standard reaction Gibbs potential $\Delta_r G^\ominus$; the rest of the change is due to mixing.

It can easily be concluded from the above discussion that the equilibrium composition can be in between the reactant ($\xi = 0$) and the product ($\xi = 1$) state, far from either of them, if the Gibbs potential of mixing is comparable to that of the reaction. In the example shown in the figure, $\Delta_r G^\ominus$ is 4.80 kJ mol^{-1} , while RT is $4.157 \text{ kJ mol}^{-1}$. The proximity of these two values enables mixing to compete with the change due to the reaction. Fig. 8.2 shows the Gibbs potential of mixing of the reaction mixture at 500 K anew, and a similar diagram valid at 298.15 K; in both cases calculated from (8.31) applying ideal mixture approximation, using data at 1 bar pressure. At the lower temperature of 298.15 K, $\Delta_r G^\ominus = -16.367 \text{ kJ mol}^{-1}$, while RT is only $2.478 \text{ kJ mol}^{-1}$. As we can see from the figure, this difference is already sufficient to shift the equilibrium very close to completion of the reaction. Note that the Gibbs potential of mixing also means a smaller contribution to the overall Gibbs potential at the lower temperature; its value is merely $-2.776 \text{ kJ mol}^{-1}$ compared to $-4.675 \text{ kJ mol}^{-1}$.

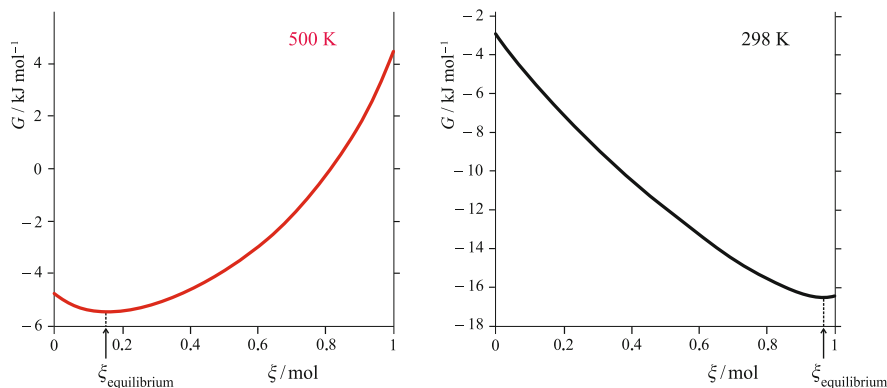

Fig. 8.2 Gibbs potential as a function of the extent of reaction ξ at temperatures 500 K (226.85°C) and 298.15 K (25°C) and a pressure of 1 bar for the reaction $\frac{1}{2} \text{H}_2 + \frac{1}{2} \text{N}_2 = \text{NH}_3$ in a mixture where the initial state contains only $\frac{1}{2}$ mol H_2 and $\frac{1}{2}$ mol N_2 without any NH_3 . The equilibrium composition is close to the reactants at 500 K but it is shifted close to the product at 298.15 K

The higher the temperature, the more the equilibrium is shifted towards smaller extent of reaction. For example, at 1000 K, $\Delta_r G^\ominus = 61.91 \text{ kJ mol}^{-1}$, while RT increases to $8.135 \text{ kJ mol}^{-1}$, which results in the extent of reaction in equilibrium of $\xi = 0.003$. This small conversion could not even be seen in the figure, it is so close to the pure reactants' state. (The temperature dependence of the equilibrium constant is discussed in detail in Section 8.4.) From the values discussed above, we can conclude that, at temperatures not much different from room temperature, reactants would not react in a detectable amount if the standard reaction Gibbs potential is 100 kJ mol^{-1} or higher. (The conversion is less than 10^{-10} .) Similarly, if the standard reaction Gibbs potential is -100 kJ mol^{-1} or lower, the reaction is practically completed in equilibrium. (The conversion differs less than 10^{-10} from 1.)

Note that a great affinity does not always mean that the reaction would take place in reality. The reason for this is the *activation barrier* meaning that the reaction could only occur via molecular interactions for which reactant molecules do not have enough energy at the given temperature. For example, most organic compounds are not in equilibrium in presence of oxygen, but the reaction with oxygen (burning) cannot take place due to the lack of sufficient energy of molecules. (To burn an organic substance, temperature must be raised above ignition temperature and conditions must be provided that heat delivered during the exothermic reaction could not dissipate easily, thus maintaining the necessary temperature.) The formation of ammonia from its elements shown in the previous figures does not take place either at room temperature, even if the equilibrium would be at quite high conversion. An efficient catalyst is needed in the mixture of N_2 and H_2 to make it possible for ammonia to form until equilibrium composition is achieved.

8.2 The Equilibrium Constant in Terms of Different Activities

In the previous section, we have stated that the equilibrium constant is only unique if the stoichiometric equation is given. We shall discuss now its dependence on the reference state; i.e., the choice of the standard state. Similarly to the discussion of mixture properties, we can base our analysis on the fact that the value of the chemical potential of a component does not depend on this choice, thus the equation

$$\sum_{i=1}^R v_i \mu_i = \sum_{i=1}^R v_i (\mu_i^\ominus + RT \ln a_i) = 0 \quad (8.32)$$

always holds. However – as discussed in Sect. 6.3.4 – the division of this value μ_i into a concentration-independent standard potential μ_i^\ominus and the concentration-dependent term $RT \ln a_i$ *does depend* on the reference state.

The choice of this state is based on practical aspects also when describing equilibria of reactions. In case of gas phase reactions, the pure substance is the reference state, and the relative activity is the fugacity divided by the total pressure. If there are reactants in a liquid-phase reaction, which are not liquid in their pure state, or whose solubility is limited in the reaction mixture, the practical reference state is the ideally dilute solution. The corresponding activity in this case may be either the rational activity on mole fraction basis, or relative activities on molarity or molality basis. To show the consequence of the actual type of activity used, let us write in (8.18) the activities expressed with the corresponding concentrations (or with the partial pressure):

$$K_a = \prod_{i=1}^R (f_i x_i)^{v_i} = \prod_{i=1}^R (x_i)^{v_i} \prod_{i=1}^R (f_i)^{v_i} = K_x K_f, \quad (8.33)$$

$$K_a = \prod_{i=1}^R (\gamma_{x,i} x_i)^{v_i} = \prod_{i=1}^R (x_i)^{v_i} \prod_{i=1}^R (\gamma_{x,i})^{v_i} = K_x K_{\gamma_x}, \quad (8.34)$$

$$K_a = \prod_{i=1}^R \left(\gamma_{c,i} \frac{c_i}{c^\ominus} \right)^{v_i} = \prod_{i=1}^R \left(\frac{c_i}{c^\ominus} \right)^{v_i} \prod_{i=1}^R (\gamma_{c,i})^{v_i} = K_c K_{\gamma_c}, \quad (8.35)$$

$$K_a = \prod_{i=1}^R \left(\gamma_{m,i} \frac{m_i}{m^\ominus} \right)^{v_i} = \prod_{i=1}^R \left(\frac{m_i}{m^\ominus} \right)^{v_i} \prod_{i=1}^R (\gamma_{c,i})^{v_i} = K_m K_{\gamma_m}, \quad (8.36)$$

$$\begin{aligned} K_a &= \prod_{i=1}^R \left(\varphi_i \frac{p_i}{P^\ominus} \right)^{v_i} = \prod_{i=1}^R \left(\frac{p_i}{P^\ominus} \right)^{v_i} \prod_{i=1}^R (\varphi_i)^{v_i} \\ &= \prod_{i=1}^R (p_i)^{v_i} \prod_{i=1}^R \left(\frac{1}{P^\ominus} \right)^{v_i} \prod_{i=1}^R (\varphi_i)^{v_i} = \frac{K_p K_\varphi}{(P^\ominus)^{\sum v_i}}. \end{aligned} \quad (8.37)$$

As we see, the expressions K_x , K_c , K_m , and K_p calculated using concentrations (or partial pressures) instead of the activities should be multiplied by the expressions K_f , K_{γ_x} , K_{γ_c} , K_{γ_m} , and $K_\varphi (P^\ominus)^{\sum v_i}$ calculated using the respective activity coefficients

to get the concentration-independent equilibrium constant K_a . In the expression $K_\varphi (P^\ominus)^{\sum v_i}$, P^\ominus is the reference pressure (the standard pressure) and $\sum v_i$ is the sum of stoichiometric numbers, which is the change in number of moles in one mole stoichiometric equation.

Accordingly, if we consider the reactive mixture to be an ideal mixture, we use the approximation of the “true” activities by the concentrations, and we can consider the *apparent equilibrium constants* K_x , K_c , and K_m as concentration independent within this approximation. However, the apparent equilibrium constant K_p expressed with partial pressures is not always pressure independent, even if the gas mixture can be considered as an ideal mixture. If the sum of stoichiometric numbers $\sum v_i$ is zero, K_p can be considered constant within the ideal approximation. If it is not zero (i.e., in case of gas reactions resulting in change of the total amounts of the reactive components), even in ideal mixtures, only another apparent equilibrium constant, namely

$$K = \frac{K_p}{(P^\ominus)^{\sum v_i}} \quad (8.38)$$

can be considered as pressure and concentration independent. Of course if the standard pressure P^\ominus is unity, $(P^\ominus)^{\sum v_i}$ is also identically unity. (This is the case if the standard pressure is 1 bar and partial pressures are also given in bar units. As this is typically the case when activities on concentration basis c^\ominus or m^\ominus are given – i.e., $c^\ominus = 1 \text{ mol dm}^{-3}$ and $m^\ominus = 1 \text{ mol kg}^{-1}$ – K_c and K_m do not require a similar correction.)

It is obvious from the above considerations that the apparent equilibrium constants K_x , K_c , K_m , and K_p are different in case of the ideal mixture approximation. However, they are also different if we do not use the ideal mixture approximation, as different activities in (8.33)–(8.37) are calculated based on different standard states. Accordingly, explicit forms of (8.17) can be given as follows:

$$\sum_{i=1}^R v_i \mu_i^* = -RT \ln \prod_{i=1}^R (f_i x_i)^{v_i}, \quad (8.39)$$

$$\sum_{i=1}^R v_i \mu_{x,i}^\ominus = -RT \ln \prod_{i=1}^R (\gamma_{x,i} x_i)^{v_i}, \quad (8.40)$$

$$\sum_{i=1}^R v_i \mu_{c,i}^\ominus = -RT \ln \prod_{i=1}^R \left(\gamma_{c,i} \frac{c_i}{c^\ominus} \right)^{v_i}, \quad (8.41)$$

$$\sum_{i=1}^R v_i \mu_{m,i}^\ominus = -RT \ln \prod_{i=1}^R \left(\gamma_{m,i} \frac{c_i}{m^\ominus} \right)^{v_i}, \quad (8.42)$$

$$\sum_{i=1}^R v_i \mu_i^*(P^\ominus) = -RT \ln \prod_{i=1}^R \left(\varphi_i \frac{p_i}{P^\ominus} \right)^{v_i}. \quad (8.43)$$

The left-hand side of these equations can be called the reaction standard Gibbs potential $\Delta_r G^\ominus$, but we should keep in mind that its actual expression, thus its actual value is also different for different cases. Calculating the equilibrium constant using the relative activities $f_i x_i$ has the consequence that the chemical potentials of pure components μ_i^* are used in the proper phase, at the actual pressure and temperature in the expression $\Delta_r G^\ominus = \sum_{i=1}^R \nu_i \mu_i^*$ to calculate the reaction standard Gibbs potential. Similarly, in (8.40) the reaction standard Gibbs potential is calculated from $\mu_{x,i}^\ominus$, referenced to infinitely dilute solutions; in (8.41), it is calculated from $\mu_{c,i}^\ominus$ (at $c^\ominus = 1 \text{ mol dm}^{-3}$ in a hypothetical ideal solution referenced to infinite dilution), while in (8.42), from $\mu_{m,i}^\ominus$ (at $m^\ominus = 1 \text{ mol kg}^{-1}$ in a hypothetical ideal solution referenced to infinite dilution). In (8.43), $\Delta_r G^\ominus$ is calculated from the chemical potentials $\mu_i^*(P^\ominus)$ of the pure species at the standard pressure P^\ominus .

From the above considerations, we can conclude that the value of the equilibrium constant K_a depends not only on the actual form of the stoichiometric equation but also on the reference state of the chemical potential, that is, the type of the standard chemical potential. This ambiguity is even more complicated if the reaction does not take place in a single (homogeneous) phase but in at least two phases. In this case, it should also be decided, in which phase the equilibrium condition will be formulated. There are also cases where the equilibrium condition – thus the equilibrium constant and the reaction standard Gibbs potential – is given taking into account more than one phase. In some cases, not all the activities within the same phase are expressed on the same concentration basis.

As an example, let us consider the formation of carbonic acid from water and carbon dioxide:

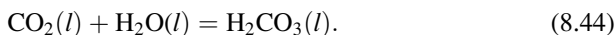

Each component is present in the liquid phase, thus it can be the reference state. It is practical to reference the activities of CO_2 and H_2CO_3 to infinite dilution, but that of the H_2O to the pure water. According to (8.18) and (8.15), the equilibrium constant and the standard reaction Gibbs potential can then be written as:

$$K_a = \frac{\gamma_{x,\text{H}_2\text{CO}_3} x_{\text{H}_2\text{CO}_3}}{f_{\text{H}_2\text{O}} x_{\text{H}_2\text{O}} \gamma_{x,\text{CO}_2} x_{\text{CO}_2}} \quad \Delta_r G^\ominus = \mu_{\text{H}_2\text{CO}_3}^\ominus - \mu_{\text{H}_2\text{O}}^* - \mu_{\text{CO}_2}^\ominus. \quad (8.45)$$

As there are mole fractions of the components in the expression of the equilibrium constant, the activity coefficient of water is referenced to the pure component, but in the case of CO_2 and H_2CO_3 , to the virtual “pure” components as if they were in the same state as in an infinitely dilute solution. Trying to interpret the standard reaction Gibbs potential, we only could imagine it as the change in Gibbs potential when from 1 mol “pure carbon dioxide” of the same state as in an infinitely dilute solution and 1 mol pure water 1 mol “pure carbonic acid” of the same state as in an infinitely dilute solution would be formed. Of course such reaction does not exist in practice, due to the limited solubility of both CO_2 and H_2CO_3 in water. (Even if they existed in a pure liquid state, this state would not be identical to that of the

respective species in an infinitely dilute solution.) For this reason, it is better to interpret the standard reaction Gibbs potential simply as a *constant* referring to a specified stoichiometric equation *and* specified standard states, without associating to it an actual change in Gibbs potential during an actual reaction.

The formation of carbonic acid can also be described by a different reaction if we allow for gas-phase carbon dioxide to be present:

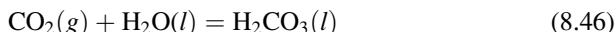

This equation is of more practical importance, especially if we write the concentration of carbon dioxide in the form of partial pressure, and that of carbonic acid and water in molar concentration. The corresponding equilibrium constant and the reaction standard Gibbs potential can be written as follows:

$$K_a = \frac{\gamma_{c,\text{H}_2\text{CO}_3}[\text{H}_2\text{CO}_3]}{\gamma_{c,\text{H}_2\text{O}}[\text{H}_2\text{O}] \varphi_{\text{CO}_2}(p_{\text{CO}_2}/P^\ominus)} \quad \Delta_r G^\ominus = \mu_{c,\text{H}_2\text{CO}_3}^\ominus - \mu_{c,\text{H}_2\text{O}}^\ominus - \mu_{\text{CO}_2}^\ominus \quad (8.47)$$

Stoichiometric formulae in brackets represent the values of molar concentration in mol dm^{-3} unit of the corresponding species, while p_{CO_2} is the *partial pressure* of carbon dioxide in the gas phase. Accordingly, in the expression of the reaction standard Gibbs potential, the standard chemical potential $\mu_{c,i}^\ominus$ of both carbon dioxide and water are referenced to a mixture in which the concentration of the given component is 1 mol dm^{-3} , but in the same (virtual) state as in an infinitely dilute solution. At the same time, the standard chemical potential $\mu_{\text{CO}_2}^\ominus$ is the chemical potential of the *pure CO₂ gas* at the standard pressure P^\ominus , given that it behaves as an ideal gas at this pressure and the actual temperature. (If we apply the ideal gas approximation at the actual partial pressure for the carbon dioxide, the value of φ_{CO_2} is unity – thus it can be omitted from the product –, and we can write the chemical potential $\mu_{\text{CO}_2}^*$ of the pure gas at pressure P^\ominus .)

The gas phase chemical potential can be written in the equilibrium conditions – according to the stoichiometric equation (8.46) – as it is *the same as that of the dissolved carbon dioxide*, due to the phase equilibrium between the gas and the liquid, and the free passage of CO_2 between the two phases. We can proceed the same way for every *heterogeneous reaction* if the reactive components mix. However, it should always be clear what concentration is used and in which phase, as the corresponding standard chemical potentials should be used in the expression for the reaction standard Gibbs potential.

8.2.1 Heterogeneous Reaction Equilibria of Immiscible Components

As explained at the end of Sect. 8.1.2, *mixing* of the components also plays a role in determining the equilibrium composition of the reaction mixture, in addition to the

reaction standard Gibbs potential. If this mixing does not involve some of the reacting components (i.e., they do not mix with other reactive species), the consequence of their mixing should not be included in the equilibrium condition. We should keep in mind that mixing is always unlimited in the gas phase, thus nonmixing reactive components can only be present in condensed phases. To describe corresponding equilibrium conditions, let us start from the general equilibrium condition for a reaction:

$$\sum_{i=1}^R v_i \mu_i = 0. \quad (8.48)$$

Let us separate the sum for the r gas phase components, and the other $R - r$ condensed phase components that do not mix with each other:

$$\sum_{i=1}^r v_i \mu_i + \sum_{i=r+1}^R v_i \mu_i = 0. \quad (8.49)$$

If the $R - r$ species in the second sum are not present in the gas phase,² and they do not mix in the condensed (usually solid) phase, their chemical potential is independent of composition. Taking this into account and expressing the gaseous components' chemical potential with their fugacity, we get the following form:

$$\sum_{i=1}^r v_i \mu_i^{\ominus} + RT \sum_{i=1}^r v_i \ln \varphi_i \left(\frac{p_i}{P^{\ominus}} \right) + \sum_{i=r+1}^R v_i \mu_i = 0. \quad (8.50)$$

The second term of the above equation can be expressed with the usual notation:

$$RT \sum_{i=1}^r v_i \ln \varphi_i \left(\frac{p_i}{P^{\ominus}} \right) = RT \ln \prod_{i=1}^r \left(\frac{\varphi_i p_i}{P^{\ominus}} \right) = RT \ln K'. \quad (8.51)$$

Rearranging this, we get the result:

$$- \sum_{i=1}^r v_i \mu_i^{\ominus} - \sum_{i=r+1}^R v_i \mu_i = RT \ln K'. \quad (8.52)$$

This result is quite similar to the usual equation describing chemical equilibrium. Its peculiarity is that, for the nonmixing condensed-phase species, it is not the

²Strictly speaking, the "nonvolatile" solid or liquid species are also present in the gas phase, even if their quantity is undetectable. The effect of these tiny quantities in mixing can be readily neglected, thus it is not necessary to take their contribution into account. These tiny amounts would not play a perceptible role in determining the equilibrium of the reaction either; the reaction is typically much faster than the evaporation of the "nonvolatile" species.

standard chemical potential at the standard pressure P^\ominus , which is written in the sum, but the chemical potential at the actual pressure of the reaction mixture. Let us examine how we can calculate this chemical potential from the standard chemical potential at the standard pressure P^\ominus . According to (6.31), the chemical potential at constant pressure and composition (in this case, in the pure state) can be calculated using the following expression:

$$\mu_i = \mu_i^\ominus + \int_{P^\ominus}^p v_i dP = \mu_i^\ominus + v_i(p - P^\ominus). \quad (8.53)$$

During integration, it is supposed that the molar volume v_i does not depend on temperature – a fairly good approximation for solids even in a wide pressure range. We can apply another approximation; the molar volume v_i of solids is so small that the product $v_i(p - P^\ominus)$ can be neglected compared to the standard chemical potential μ_i^\ominus . Consequently, the sum of the products $v_i \mu_i$ is approximately the same as that of $v_i \mu_i^\ominus$ at pressures not too much higher than P^\ominus :

$$\sum_{i=r+1}^R v_i \mu_i = \sum_{i=r+1}^R v_i \mu_i^\ominus + (p - P^\ominus) \sum_{i=r+1}^R v_i v_i \cong \sum_{i=r+1}^R v_i \mu_i^\ominus. \quad (8.54)$$

In condensed phases, the difference of the molar volume of products and reactants $\sum_{i=r+1}^R v_i v_i$ is also negligible compared to the difference of the standard chemical potentials, thus – at moderately high pressures – the following equation can be considered as valid:

$$-\Delta_r G^\ominus = \sum_{i=r+1}^R v_i \mu_i^\ominus = RT \ln K'. \quad (8.55)$$

In other words, the *reduced equilibrium constant* K' can be expressed using the reaction standard Gibbs potential for the original stoichiometric equation.

Let us illustrate the above general principles by the example of the *calcination of limestone*. The stoichiometric equation can be written as:

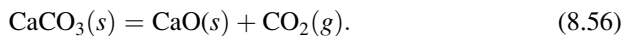

The gas phase contains only CO_2 from the reactive species, while CaCO_3 and CaO are in the solid phase but they do not mix. According to the above described results, the reduced equilibrium constant and the reaction standard Gibbs potential can be written as:

$$K' = \varphi_{\text{CO}_2}(p_{\text{CO}_2}/P^\ominus) \quad \Delta_r G^\ominus = \mu_{\text{CaCO}_3}^*(s) - \mu_{\text{CaO}}^*(s) - \mu_{\text{CO}_2}^\ominus(P^\ominus). \quad (8.57)$$

These expressions include only the approximation valid for the solids at moderate pressures; properties of the CO_2 gas are properly taken into account by the fugacity coefficient and the standard chemical potential referenced to the hypothetical ideal gas behavior. Note that the validity does not depend on the actual quantity of the reactive species in the solid phase; it is essential only that some quantity be present to maintain equilibrium.

It is common practice also to consider the gas phase reactant as an ideal gas, and ignore the division by the standard pressure P^\ominus in the equilibrium constant. This leads to the simplified formulae that can be seen in many textbooks and handbooks:

$$K' = p_{\text{CO}_2} \quad \Delta_r G^\ominus = \mu_{\text{CaCO}_3}^*(s) - \mu_{\text{CaO}}^*(s) - \mu_{\text{CO}_2}^*(g). \quad (8.58)$$

However, it is important to know that p_{CO_2} (and, in general, partial pressures in similar expressions) should be understood as the *value* of pressure in the unit of the pressure at which the chemical potential of the pure component in the expression of $\Delta_r G^\ominus$ is determined (usually 101 325 Pa, or 1 bar = 10^5 Pa). Within this approximation, the partial pressure of carbon dioxide at which the reaction is in equilibrium can be calculated from the equilibrium constant K' using (8.20). If the partial pressure of CO_2 at the actual temperature is less than this, CaCO_3 will *completely decompose*. This is the case during lime burning when fresh air flows to burn the coal sweeps the carbon dioxide from the hot reaction zone, thus the product is pure quicklime (CaO). If the partial pressure of CO_2 is higher than the equilibrium pressure, the reaction is reversed; CaCO_3 is formed from calcium oxide and carbon dioxide. In case the partial pressure is continuously maintained above the equilibrium level, the reverse reaction also proceeds to completion. (Contrarily to homogeneous reactions where mixing does not allow the reaction to complete in either direction.)

The results can readily be applied also for reactions when the gas phase contains more than one reacting species. It can be illustrated by the reaction

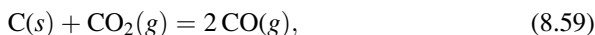

where carbon is only present in the solid phase and neither CO nor CO_2 present in the gas phase dissolve in it. Applying the ideal gas mixture approach for the gas phase and omitting the division by P^\ominus , the reduced equilibrium constant and the standard Gibbs potential of the reaction can be written the following way:

$$K' = \frac{(p_{\text{CO}})^2}{p_{\text{CO}_2}} \quad \Delta_r G^\ominus = 2\mu_{\text{CO}}^*(g) - \mu_{\text{C}}^*(s) - \mu_{\text{CO}_2}^*(g). \quad (8.60)$$

During this reaction, the equilibrium ratio of the partial pressures of CO and CO_2 will always be adjusted to the value prescribed by the equilibrium constant (if the temperature is high enough that the reaction of the two gases in contact with coal can proceed). The condition for the equilibrium to be achieved requires, of course, that there should be enough coal to be oxidized, or there should be enough carbon monoxide

to disproportionate; depending on the actual direction of the reaction. A continuous flow of CO_2 will result in the complete transformation of the coal to carbon monoxide.

Heterogeneous reactions are also important in the formation of minerals in rocks. At large depths in the earth crust, pressure can be so high that the pressure dependence of the chemical potential of the solid reactants cannot be neglected. By analyzing the composition of the reactive species, it is possible to determine the pressure acting on the rocks by the time the minerals have been formed. For this reason, these rocks are also called *geobarometers*.

8.3 Calculation of the Equilibrium Constant from Thermodynamic Data

As already mentioned, the equilibrium constant can be determined by measuring the concentrations of the reacting species and substituting them into the expression of the equilibrium constant. To do so, it is necessary to have the physical realization of the reaction mixture at equilibrium, and experimentally determine all the relevant concentrations. If there exist thermodynamic data for the reacting components, (8.20) largely facilitates the task; the equilibrium constant can be calculated from the reaction standard Gibbs potential.

In this section, we explore the possibility to calculate the reaction standard Gibbs potential from measurable thermodynamic quantities. According to (8.15), the necessary quantities to be calculated are the standard chemical potentials of the reacting species.

We can use (6.9) to calculate standard chemical potentials μ_i^\ominus as:

$$\mu_i^\ominus = H_i^\ominus - TS_i^\ominus. \quad (8.61)$$

In this equation, H_i^\ominus is the standard partial molar enthalpy while S_i^\ominus is the standard partial molar entropy at the pressure P^\ominus , in a state according to the standard (i.e., in its pure state or at unit concentration).

Thus, H_i^\ominus is either the molar enthalpy of the pure substance or the partial molar enthalpy of the component after mixing. Knowing the thermodynamic properties of the actual mixture, we can use (6.125) to calculate the enthalpy of mixing, from which we can calculate H_i^\ominus in the mixture. One of the tasks is thus to determine the standard enthalpy of pure substances at a given temperature T . Let us see first that to do so, it is sufficient to know the standard enthalpy at an arbitrary temperature and the function c_P , the constant-pressure heat capacity at the pressure P^\ominus . According to (4.25), it is possible then to calculate the standard enthalpy at any other temperature:

$$H_i^\ominus(T_2) = H_i^\ominus(T_1) + \int_{T_1}^{T_2} c_{P,i}^\ominus dt. \quad (8.62)$$

Thus, it is sufficient to determine the molar enthalpy at one single temperature, using calorimetric measurements. According to this condition, we usually find

molar enthalpies H_i^\ominus calculated using the above equation at the temperature of 25°C, i.e., at 298.15 K, called usually as *standard heats of formation*. The background of this name is that the molar enthalpy is the enthalpy of formation of a given substance from its elements, as the enthalpy of pure elements in their stable state at the standard pressure (of 1 bar) is zero by definition. The usual symbol for the standard heat of formation is $\Delta_f H_i^\ominus$. We recall here that the scale of the internal energy – and thus of all other energy-like state functions derived from it – is not unique; there is always an arbitrary additive constant involved. The additive constant mentioned at the end of Sect. 2.1.1 is also fixed using the mentioned convention. Fixing the scale of enthalpy instead of the internal energy is supported by practical reasons. On the one hand, standard enthalpies are more directly related to the calculation of equilibrium constant – as seen from (8.61). On the other hand, it is easier to determine the heat effect of reactions at a constant pressure (i.e., $\Delta_r H$) than at constant volume (i.e., $\Delta_r U$).

Having seen the method to calculate standard partial molar enthalpies H_i^\ominus , let us explore how to calculate standard partial molar entropies S_i^\ominus . Recalling that the scale of entropy – contrarily to that of the energy – is uniquely determined, its temperature dependence can be written based on (4.41) as

$$S_i^\ominus(T) = S_0(T_0 = 0) + \int_0^T \frac{c_{P,i}^\ominus}{T} dT. \quad (8.63)$$

Knowing that $S_0(T_0 = 0)$ – according to Postulate 4 – the standard partial molar entropy can always be calculated if the constant-pressure molar heat capacity c_P is available. It is important to know how to proceed if there is a phase-transition below the temperature of the upper limit of integration. In this case, we only integrate until the temperature of the phase transition, then add the entropy of the phase transition, and then continue integration from the temperature of the phase transition but with the heat capacity c_P of the newly formed phase.

Summing up, we can state that we need the standard enthalpies (of formation) H_i^\ominus and the constant-pressure molar heat capacities $c_{P,i}^\ominus$ (at the standard pressure P^\ominus) of the reacting species to calculate the reaction standard Gibbs potential $\Delta_r G^\ominus$. The heat-capacity function should be applicable from around 0 K until the temperature, where we want to calculate $\Delta_r G^\ominus$. The calculation can be formalized in a compact equation, using the following notation:

$$\Delta_r H^\ominus = \sum_{i=1}^R v_i H_i^\ominus \quad \Delta_r C_P^\ominus = \sum_{i=1}^R v_i c_{P,i}^\ominus \quad \Delta_r S^\ominus = \sum_{i=1}^R v_i S_i^\ominus. \quad (8.64)$$

The compact form then reads as:

$$\Delta_r G^\ominus(T) = \Delta_r H^\ominus(T) + \int_{298.15\text{K}}^T \Delta_r C_P^\ominus dt - T \int_{0\text{K}}^T \frac{\Delta_r C_P^\ominus}{T} dt. \quad (8.65)$$

Note that the second integral includes also the entropy changes of eventual phase transitions. T is the temperature at which we want to get $\Delta_r G^\ominus$ while t is the integration variable referring to temperature.

Equation (8.65) reflects the fact that the equilibrium constant of chemical reactions is uniquely determined, and that to calculate it, it is sufficient to know the relevant reaction enthalpies and the heat capacity functions. Practical calculations are usually even more simple, as in thermodynamic tables containing necessary standard enthalpies of formation H_i^\ominus , we can also find the standard entropies of formation S_i^\ominus – calculated using (8.63), usually at 298.15 K. In terms of these data, we can use the following formula to calculate $\Delta_r G^\ominus$:

$$\Delta_r G^\ominus(T) = \Delta_r H^\ominus(298.15\text{K}) + \int_{298.15\text{K}}^T \Delta_r C_P^\ominus dt - T\Delta_r S^\ominus(298.15\text{K}) - T \int_{298.15\text{K}}^T \frac{\Delta_r C_P^\ominus}{T} dt. \quad (8.66)$$

If there exist thermodynamic data containing H_i^\ominus and S_i^\ominus values at the actual temperature T , we can even avoid doing the integrations.

The equation

$$\Delta_r G^\ominus(T) = \Delta_r H^\ominus(T) - T\Delta_r S^\ominus(T), \quad (8.67)$$

which is equivalent to (8.61) and was also used when writing (8.65), elucidates an important property of the reaction standard Gibbs potential $\Delta_r G^\ominus$. It is readily seen from the equation that the quantity that determines the equilibrium of the reaction at temperatures not much higher than zero is the heat of the reaction $\Delta_r H^\ominus$, as the product $T\Delta_r S^\ominus$ is very small compared to $\Delta_r H^\ominus$. As the temperature is raised, the contribution of the product $T\Delta_r S^\ominus$ becomes higher and higher. Supposing that $\Delta_r H^\ominus$ and $\Delta_r S^\ominus$ do not change significantly with temperature (which is usually a good approximation at around room temperature up to even a few hundreds of K), we can say that the product $T\Delta_r S^\ominus$ increases proportionally to temperature. This applies approximately also for the formation of ammonia discussed in Sect. 8.1.2. The value of $\Delta_r G^\ominus$ for this reaction, relative to (8.21) is -16.367 kJ/mol at 298.15 K, but it is only 4.80 kJ/mol at 500 K. At the same temperatures, the value of $\Delta_r H^\ominus$ changes from -45.90 kJ/mol to only -49.86 kJ/mol, and $\Delta_r S^\ominus$ from -99.05 kJ/(mol K) to only -109.32 kJ/(mol K), respectively.

It is worth mentioning the great importance in the thermodynamics of chemical reactions of Postulate 4 that fixes the scale of entropy. It would be impossible to determine an eventual arbitrary additional constant for the entropies of individual components. To determine the entropy differences between different components is also not feasible – contrarily to differences of energy or enthalpy. Thus, without the knowledge of the entropy scale provided by Postulate 4, the equilibrium constant of chemical reactions could not be determined in a unique way.

8.4 Temperature and Pressure Dependence of the Equilibrium Constant

Although we have dealt with the temperature dependence of the equilibrium constant in the previous section, it is practical to apply a simpler and more straightforward formalism for this purpose. To derive the temperature and pressure dependence of the equilibrium constant, we can start from (8.19) written in the following form:

$$\ln K_a = -\frac{1}{R} \frac{\Delta_r G^\ominus}{T}. \quad (8.68)$$

Based on this, the temperature dependence of $\ln K_a$ can be derived from the known dependence of $\Delta_r G^\ominus$. The total differential of $\Delta_r G^\ominus$ can be written, according to (4.22), as:

$$d\Delta_r G^\ominus = -\Delta_r S^\ominus dT + \Delta_r V^\ominus dP. \quad (8.69)$$

(There are only two terms in the equation as the standard Gibbs potential does not depend on composition.) We can readily see in the equation that the derivatives with respect to temperature and pressure are the following:

$$\left(\frac{\partial \Delta_r G^\ominus}{\partial T}\right)_P = -\Delta_r S^\ominus \quad \left(\frac{\partial \Delta_r G^\ominus}{\partial P}\right)_T = \Delta_r V^\ominus \quad (8.70)$$

Starting from (8.68) we can find another expression for the temperature dependence of $\ln K_a$. Let us start with the differentiation of the equation:

$$\left(\frac{\partial \ln K_a}{\partial T}\right)_P = -\frac{1}{R} \frac{\partial}{\partial T} \left(\frac{\Delta_r G^\ominus}{T}\right)_P. \quad (8.71)$$

We can apply for the derivative on the right-hand side the *Gibbs-Helmholtz equation*:

$$\frac{\partial}{\partial T} \left(\frac{G}{T}\right)_P = \left(\frac{\partial(G/T)}{\partial T}\right)_P = -\frac{H}{T^2}. \quad (8.72)$$

Thus, (8.71) can be written in the following form:

$$\left(\frac{\partial \ln K_a}{\partial T}\right)_P = \frac{\Delta_r H^\ominus}{RT^2}. \quad (8.73)$$

As temperature is still included in the derivative, it is worth to change the variable of derivation using

$$\frac{d(1/T)}{dT} = -\frac{1}{T^2} \quad \rightarrow \quad \frac{1}{T^2} dT = -d\left(\frac{1}{T}\right) \quad (8.74)$$

This variable change results in the following expression:

$$\left(\frac{\partial \ln K_a}{\partial (1/T)}\right)_P = -\frac{\Delta_r H^\ominus}{R}. \quad (8.75)$$

Both (8.73) and (8.75) are usually called *van't Hoff equation*. It is straightforward to use the last form, from which we readily see that for exothermic reactions (for which $\Delta_r H^\ominus$ is negative) the equilibrium constant decreases with increasing temperature (i.e., when $1/T$ decreases). Similarly, for endothermic reactions (for which $\Delta_r H^\ominus$ is positive), the equilibrium constant increases with increasing temperature (i.e., when $1/T$ decreases). The simplicity of (8.75) is reflected also in the common practice to plot the temperature dependence of the logarithm of K_a in the form of $\ln K_a$ versus $1/T$. If we accept the approximation that $\Delta_r H^\ominus$ does not depend on temperature, we can expect that experimentally determined values are all along a straight line whose slope is $-\Delta_r H^\ominus/R$. From the experimental data, we can also determine the value of $\Delta_r H^\ominus$. However, it is not a good practice to determine this from the estimation of the slope of the linearized $\ln K_a$ versus $1/T$ function as this can lead to the distortion of the estimation of $\Delta_r H^\ominus$. A more correct procedure is to estimate the parameter $\Delta_r H^\ominus$ directly from the K_a versus T function, taking into account the experimental errors of the individual K_a values. This procedure leads to an unbiased estimate of $\Delta_r H^\ominus$. This function can be obtained by indefinite integration of (8.75) after having separated its variables:

$$\ln K_a = -\frac{\Delta_r H^\ominus}{R} \frac{1}{T} + \ln A. \quad (8.76)$$

The undetermined integration constant has been chosen as $\ln A$, which leads to a simple expression of the $K_a - T$ function:

$$K_a = A e^{-\frac{\Delta_r H^\ominus}{RT}} \quad (8.77)$$

The two parameters to estimate from the experimental data are $\Delta_r H^\ominus$ in the exponent and the factor of the exponential, A . Note that this procedure is the reverse of determining the equilibrium constant from calorimetric data; in this case, the heat of reaction is calculated from the measurement of equilibrium concentrations.

The definite integration of (8.75) leads to the following result:

$$\ln K_2 - \ln K_1 = -\frac{\Delta_r H^\ominus}{R} \left(\frac{1}{T_2} - \frac{1}{T_1} \right). \quad (8.78)$$

This is readily rearranged in the usual form

$$\ln K_2 = \ln K_1 - \frac{\Delta_r H^\ominus}{R} \left(\frac{1}{T_2} - \frac{1}{T_1} \right), \quad (8.79)$$

which can be used to calculate the equilibrium constant at temperature T_2 if we know its value at temperature T_1 . (The condition of validity is of course that the temperature dependence of $\Delta_r H^\ominus$ be negligible in the range between T_1 and T_2 .)

The pressure dependence of the equilibrium constant can be obtained directly from the partial derivative shown in (8.70):

$$\left(\frac{\partial \ln K_a}{\partial P}\right)_T = -\frac{\Delta_r V^\ominus}{RT}. \quad (8.80)$$

According to this result, the equilibrium constant increases with increasing pressure if the *reaction standard volume* $\Delta_r V^\ominus = \sum_{i=1}^R v_i V_i^\ominus$ is negative, that is, the volume decreases when the reaction proceeds. Conversely, it decreases with increasing pressure if the volume increases when the reaction proceeds. In case of gas reactions, if there is a change in the stoichiometric numbers summed on the two sides of the equation ($\sum v_i$ is nonzero), this leads to important pressure dependence. (Cf. Sect. 8.2). If $\sum v_i$ is zero, then the volume will not change, thus the equilibrium constant is pressure independent within the ideal mixture approximation. In condensed phases, the volume change is typically much smaller than in a gas reaction, thus the pressure dependence is also smaller.

Supposing that the pressure dependence of $\Delta_r V^\ominus$ itself is negligible within the studied pressure range, experimental values in a plot of $\ln K_a$ versus P should be along a straight line whose slope is proportional to $-\Delta_r V^\ominus$. Accordingly, the standard reaction volume $\Delta_r V^\ominus$ can be estimated from these data. For condensed-phase reactions where the volume change is small, a special device made of diamond – the diamond anvil cell (DAC) – is used, as the deformation of diamond is very small even at large pressures. The DAC consists of two small high-quality gem diamonds of the shape of an anvil, and there is a little cavity between the two where solids and liquids can be compressed to ultrahigh pressures of several GPa, that is, to several tens of millions of the atmospheric pressure. The anvils are compressed using a first-class lever and a screw. In case of liquid samples, there is a gasket between the two anvils, which withstands lateral pressure but deforms in the direction of the axis of pressure. Using this device, equilibria of reactions in great depths of Earth can be studied.

8.4.1 The Le Châtelier–Braun Principle

Let us apply (8.25) for a chemical reaction, omitting the change of the nonreactive species:

$$dG = -SdT + VdP + \left(\sum_{i=1}^R v_i \mu_i\right) d\xi = 0. \quad (8.81)$$

This equation formulates the condition of the minimum of Gibbs potential in equilibrium. Taking into account (8.26), we can rewrite the above equation in the following form:

$$dG = -SdT + VdP + \left(\frac{\partial G}{\partial \xi}\right)_{T,P} d\xi = 0. \quad (8.82)$$

Let us differentiate both sides with respect to the extent of reaction ξ :

$$d\left(\frac{\partial G}{\partial \xi}\right)_{T,P} = -\left(\frac{\partial S}{\partial \xi}\right)_{T,P} dT + \left(\frac{\partial V}{\partial \xi}\right)_{T,P} dP + \left(\frac{\partial^2 G}{\partial \xi^2}\right)_{T,P} d\xi = 0. \quad (8.83)$$

At constant pressure ($dP = 0$), we get the following expression:

$$\left(\frac{\partial \xi}{\partial T}\right)_P = \frac{\left(\frac{\partial S}{\partial \xi}\right)_{T,P}}{\left(\frac{\partial^2 G}{\partial \xi^2}\right)_{T,P}}. \quad (8.84)$$

At constant temperature and pressure, we can substitute $\partial H/T$ in place of ∂S :

$$\left(\frac{\partial \xi}{\partial T}\right)_P = \frac{\frac{1}{T} \left(\frac{\partial H}{\partial \xi}\right)_{T,P}}{\left(\frac{\partial^2 G}{\partial \xi^2}\right)_{T,P}} \quad (8.85)$$

If the temperature is constant ($dT = 0$), we get the following expression:

$$\left(\frac{\partial \xi}{\partial P}\right)_T = -\frac{\left(\frac{\partial V}{\partial \xi}\right)_{T,P}}{\left(\frac{\partial^2 G}{\partial \xi^2}\right)_{T,P}}. \quad (8.86)$$

The Gibbs potential should be minimal in equilibrium, which is equivalent to the criterion of *stability* (cf. Sect. 7.1):

$$d^2G > 0 \quad (8.87)$$

One of the conditions of this inequality is that $(\partial^2 G / \partial \xi^2)_{T,P}$ should be positive. Due to this condition, we can conclude from (8.85) that

$$\text{if } \left(\frac{\partial H}{\partial \xi}\right)_{T,P} > 0, \quad \text{then } \left(\frac{\partial \xi}{\partial T}\right)_P > 0. \quad (8.88)$$

Accordingly, if the reaction is endothermic, an increase in temperature results in a shift of the equilibrium towards the products. Conversely, in case of an

exothermic reaction, the equilibrium shifts towards the reactants if the temperature increases.

Similarly, from (8.86) we can conclude that

$$\text{if } \left(\frac{\partial V}{\partial \xi}\right)_{T,P} > 0, \quad \text{then } \left(\frac{\partial \xi}{\partial P}\right)_T < 0. \quad (8.89)$$

This has the consequence that, if the forward reaction results in an increase of the volume, then the equilibrium shifts towards the products when the pressure is increased. Conversely, in case of a reaction which decreases the volume, the equilibrium shifts towards the reactants when the pressure is increased. These results are of course in agreement with the conclusions made of the temperature- and pressure-dependence of the equilibrium constant as stated in Sect. 8.4.

The above principle can be derived for thermodynamic equilibria in general. It has been described first independently by Le Châtelier and Braun³ also in connection with chemical reactions, which is the reason why it is called the *Le Châtelier–Braun principle*. Its general form reads as follows: any change in the conditions of equilibrium prompts an opposing consequence in the responding system to diminish the effect of the change.

For a chemical reaction it means that the increase of temperature induces the endothermic reaction whose heat effect counterbalances the increase of temperature. If the pressure is increased, it favors the reaction which decreases the volume, thus counteracting the increase of pressure. If the concentration of a reacting component is increased, the reaction induced will decrease the concentration of this species.

Problems

1. The equilibrium constant of a particular chemical reaction in the vicinity of $T = 502.3$ K can be calculated using the following equation:

$$\ln K = 1 - 1000 \left(\frac{T}{\text{K}}\right)^{-1} + 20000 \left(\frac{T}{\text{K}}\right)^{-2}.$$

Calculate the standard reaction enthalpy and entropy at the given temperature.

³The French chemist Henri Louis Le Châtelier (1850–1936) had presented his results, concerning the response of chemical reactions to changes in conditions, in 1885 to the French Academy, and published them in 1888. Independently of him, the German physicist Karl Ferdinand Braun (1850–1918) published similar results in 1877. (Braun received the Nobel prize in 1909 for his contribution to the development of the “wireless telegraph” – the radio – together with Marconi.) It is interesting to note that Le Châtelier has cited in his publication the result described in the book of van’t Hoff published in 1884 (*Études de dynamique chimique*), which correctly describes the change of the chemical equilibrium constant with temperature. (It is a characteristic of the humble and understanding personality of van’t Hoff that – despite this fact – he later cited this result as Le Châtelier’s principle.)

Solution: Let us start with the form of the van't Hoff equation according to (8.73):

$$\left(\frac{\partial \ln K_a}{\partial T}\right)_P = \frac{\Delta_r H^\ominus}{RT^2}.$$

As we can see, by calculating the derivative of $\ln K$ with respect to the temperature from the given formula, we readily obtain the reaction enthalpy (7.652 kJ mol⁻¹). The reaction entropy can be calculated using the following relation:

$$\Delta_r S^\ominus = \frac{\Delta_r H^\ominus - \Delta_r G^\ominus}{T}.$$

The missing $\Delta_r G^\ominus$ can be calculated using the relation (8.19):

$$-\Delta_r G^\ominus = RT \ln K_a$$

The result is $\Delta_r S^\ominus = 7.655 \text{ J}/(\text{mol K})$.

- The equilibrium constant of a particular chemical reaction is doubled when elevating the temperature from 200 K to 300 K. Calculate the reaction enthalpy (considering it as independent of temperature in this range).

Solution: Let us apply this time the definite integral form of the van't Hoff equation according to (8.78):

$$\ln \frac{K_2}{K_1} = -\frac{\Delta_r H^\ominus}{R} \left(\frac{1}{T_2} - \frac{1}{T_1} \right).$$

Solution of this equation yields $\Delta_r H^\ominus = 3.458 \text{ kJ/mol}$.

Further Reading

- Atkins P, de Paula J (2009) Physical chemistry, 9th edn. Oxford University Press, Oxford
- Balzhiser RE, Samuels MR, Eliassen JD (1972) Chemical engineering thermodynamics – the study of energy, entropy, and equilibrium. Prentice-Hall, Englewood Cliffs, NJ
- Denbigh KG (1981) The principles of chemical equilibrium, 4th edn. Cambridge University Press, Cambridge
- Guggenheim EA (1985) Thermodynamics: an advanced treatment for chemists and physicists, 7th edn. North Holland, Amsterdam
- IUPAC (2007) Quantities, units and symbols in physical chemistry, 3rd edn. RSC Publishing, Cambridge
- Silbey LJ, Alberty RA, Mounji GB (2004) Physical chemistry, 4th edn. Wiley, New York

Chapter 9

Extension of Thermodynamics for Additional Interactions (Non-Simple Systems)

In previous chapters, we have discussed the thermodynamic description of systems, which contained several phases, allowing also for chemical reactions to occur. However, we have supposed that only mechanical and thermal interactions can take place between the system and its surroundings, and considered the system consisting of electrically neutral and non-magnetic particles; we have also excluded interactions with external fields, and supposed that the system (or its phases) is isotropic and has a small surface whose changes can be neglected. In this chapter, we shall briefly discuss the possibility of including further interactions and the release of the mentioned constraints in the thermodynamic description. We also treat somewhat more detailed the thermodynamics of a few interactions that occur more frequently in the chemical praxis.

As stated by Postulate 1, the equilibrium state of simple systems consisting of K chemical components can completely be described by $K + 2$ extensive variables, which – in case of energy representation – are entropy S , volume V and composition specified by the amounts of components n_1, n_2, \dots, n_K . In other words, a simple system has $K + 2$ degrees of freedom. The total differential of the energy function, according to (2.22), contains terms of energy dimension, each of them being the product of an intensive variable and the increment of an extensive variable. The intensive variable in this product is the partial derivative of the energy function with respect to the variable whose increment is the factor in the actual term. These terms contribute as *work* to the increment of energy, except for the term TdS , which is the *heat* contribution. Thus, we call $-PdV$ the volume work and the sum of the terms $\mu_i dn_i$ the chemical work. The former is the consequence of mechanical interactions, while the latter is the consequence of chemical interactions contributing to the change in energy.

If we allow for other interactions between the system and its surroundings, we should add other variables to specify the state and its energy. Accordingly, additional products of similar structure will also appear in the total differential of the energy function, which also contains the new intensive variables multiplied by the increments of the respective extensive variable. These terms account for the change in energy as a consequence of the new interactions.

When adding these new terms and variables to the fundamental equation, we should of course take into account the physical nature of the new interactions. In case of simple systems, all the variables were scalar quantities; consequently, the derivatives of the energy function were also scalar. Including, for example, magnetic interactions, both the extensive variable and the derivative of the energy with respect to this variable – the corresponding intensive quantity – are vectors. Treating vector variables does not mean any problems in thermodynamics (only complicates the mathematics); we should apply the corresponding formulae used in magnetostatics to calculate the work associated with the change of magnetic interactions. Let us discuss now the extensive variables and the corresponding intensive ones characteristic of the most important interactions, which can be used to determine the work done while the actual interaction would change.

As a first case, let us release the isotropy of mechanical interactions and allow for a direction-dependent deformation as the response of the system to a direction-dependent force. In a homogeneous isotropic system, Pascal's law is valid; the deforming force – which acts to change the volume – is transmitted equally in all directions, and the resistance against this force – expressed by the pressure P – is also the same in all directions.

Solid bodies can have a much more complicated behavior; in addition to compression, we can stretch, bend, shear, or twist them. Solid bodies can respond to forces of different directions with several kinds of deformations. Their shape can be distorted in a complex way especially in case of crystals, which can suffer different deformations in different directions. Accordingly, both force and deformation should be treated as vectors. For relatively small forces, the validity of Hooke's law holds; deformation is proportional to the force. This proportionality is valid for all components of the vector; every component of force (a vector) has an effect on every component of the deformation (also a vector). In terms of linear algebra, we can say that the scalar compressibility κ is replaced by a *tensor* of many elements which transforms the force vector into the deformation vector, depending on the actual direction. We should also note that in solid-state physics, the force acting relative to a unit surface is called *stress*, with its direction outward of the surface – contrarily to pressure. Consequently, we should write the product of this stress multiplied by deformation in place of the term $-PdV$ in (2.22).¹ As the deformation of crystals is not of primary interest in chemistry, we would not deal with it any further.

The mathematical formalism associated with magnetic interactions is also quite complicated. The simplest case is a system where only paramagnetic or diamagnetic interactions occur in a homogeneous magnetic field (i.e., where the field strength is uniform.) In this case, the direction of the magnetization vector² \mathbf{M} is

¹Note that stress has an opposite sign with respect to pressure, thus the term to enter into the energy increment is positive.

²In many cases, the magnetization \mathbf{M} is that of the unit volume or molar volume. Here, it means the total magnetization of the whole system, i.e., the unit volume magnetization multiplied by the volume.

parallel to the magnetic induction (or magnetic flux density) vector \mathbf{B} . If the system has the shape of an ellipsoid and one of its symmetry axes is parallel to the vector \mathbf{B} , then the fundamental equation of the system can be given as $U = U(S, V, \mathbf{M}, \mathbf{n})$, and the differential fundamental equation as:

$$dU = TdS - PdV + BdM + \sum_{i=1}^K \mu_i dn_i. \quad (9.1)$$

In a more general case, the magnetic moment \mathbf{M} in the term BdM in (9.1) should be replaced by an integral over the entire system of the position-dependent intensive magnetic moment $\mathbf{m}(\mathbf{r})$. In magnetically anisotropic crystals, magnetization is a tensor – similarly to the deformation tensor – and the expression of magnetic work in (9.1) becomes more complicated mathematically, but dU can be calculated anyway. In case of magnetic interactions, there is another peculiarity; there exist no walls that could restrict magnetization. However, this imposes no problem when describing the equilibrium of magnetic interactions.

The thermodynamic description of a system having an electric dipole moment in an electric field is similar to the magnetic case. The corresponding formulae are simplest if the direction of the *electric dipole moment* (vector) of the system is parallel to the direction of the external electric field (vector), the system has the shape of an ellipsoid and one of its symmetry axes is parallel to the dipole moment vector. In this case, the electric dipole moment \mathbf{P} (extensive variable) can be characterized with one value, as well as the external electric field strength \mathbf{E} (intensive variable) for a homogeneous isotropic system. The fundamental equation of this electrically polarized system can be given as $U = U(S, V, \mathbf{P}, \mathbf{n})$, and the differential fundamental equation as:

$$dU = TdS - PdV + EdP + \sum_{i=1}^K \mu_i dn_i. \quad (9.2)$$

If the system and/or the spatial arrangement is more complicated, the treatment of the equilibrium is similar to that of the magnetic case.

In electrostatics, there exists the “electric monopole”, i.e., the electric charge as well. This charge is a scalar quantity and it does not depend on the external field strength – contrarily to the electric or magnetic dipole moment. Accordingly, the thermodynamic description of electrically charged systems is quite simpler than that of dipoles. If the electric field is homogeneous, the interaction of the electric *potential* E (intensive) and the charge q (extensive) can be described by the energy increment calculated as the product of the intensive potential and the increment of the extensive charge, Edq . The fundamental equation of the electrically charged system can be given as $U = U(S, V, q, \mathbf{n})$, and the differential fundamental equation as:

$$dU = TdS - PdV + Edq + \sum_{i=1}^K \mu_i dn_i. \quad (9.3)$$

Many systems of practical interest in chemistry contain charged particles – mostly ions –, thus it is important to discuss the thermodynamics of these systems. For this reason, a whole section is dedicated to the description of systems containing electrically charged particles.

The description of the interaction of thermodynamic systems with a gravitational field can be similarly described as an electrically charged system interacting with an external electric field. The gravitational field also interacts with the field-independent extensive quantity, the mass. The intensive quantity characteristic of the field is the gravitational potential (sometimes simply referred to as potential); when multiplied with mass, it yields the gravitational energy. In a gravitational field, mass should also be a variable of the internal energy function. However, as the mass of a system is uniquely determined by its composition \mathbf{n} , it is not necessary to deal with it as an additional variable. Accordingly, the number of degrees of freedom of a system is not greater in a gravitational field with respect to the case when the effect of the field is neglected. This cannot be neglected if the gravitational potential changes within the system. In this case, a position-dependent gravitational potential multiplied by the increment of mass should be included in the differential fundamental equation. Within earthly conditions, this potential depends on the height h :

$$dU = TdS - PdV + (gh) dm + \sum_{i=1}^K \mu_i dn_i. \quad (9.4)$$

The quantity g is the gravitational acceleration, which can be considered constant within moderately large height differences. It is important to know that the mass increment dm is a unique function of the increments of amounts of components dn_i , which should be taken into account when calculating the internal energy. If the thermodynamic system has a small height which does not change, the contribution of gravitational potential is negligibly small compared to other terms. It is important, for example, in systems where sedimentation occurs.

In multiphase systems, there is an *interface layer* between two adjacent phases. While intensive properties (e.g., molar values of extensive quantities) are identical within homogeneous phases independently of the position, there should be a “transition region” between the two phases where differences get matched within a distance of a few molecules. A single-phase system also has an interface at the walls of the container. Describing this system, we usually treat this interface as the surface of the homogeneous phase. Interface layers can have great importance in chemistry, thus it is worth to discuss them in some detail. For this reason, a whole section is dedicated to the thermodynamics of interfaces. Here, we shall only mention the case of a homogeneous phase whose surface interactions cannot be neglected and should be considered in the internal energy. To take surface effects into account, the two-dimensional analogue of pressure is used as an intensive variable, and the corresponding extensive variable is surface. The product of the intensive *surface tension* γ multiplied by the surface A has energy dimension, thus

the fundamental equation accounting for surface interactions can be given as $U = U(S, V, A, \mathbf{n})$, and the corresponding differential fundamental equation is:

$$dU = TdS - PdV + \gamma dA + \sum_{i=1}^K \mu_i dn_i. \quad (9.5)$$

In summary, we can conclude that, in case of every new interaction in addition to those of a simple system, we should add a new extensive variable characteristic of this interaction to the variables of internal energy specified by the fundamental equation. In the differential form of the fundamental equation, a new term appears that contains the appropriate intensive variable (the partial derivative of the internal energy function with respect to the new variable) multiplied by the increment of the new extensive variable. The additional term is not necessarily as simple as those for the simple system; the new variables are neither always isotropic scalar quantities nor homogeneously distributed within the system. They can also have more specific properties, thus their inclusion needs special care. It is also important that a new interaction always increases the number of degrees of freedom $K + 2$ of the simple system.

9.1 Thermodynamics of Interfaces: Two-Dimensional Equations of State

As we have seen in the chapter on mixtures, condensed phases do not always mix. Between two (non-mixing) condensed phases (solid–liquid, solid–solid, liquid–liquid) and between a condensed phase and the gas phase (solid–gas, liquid–gas), there is always an interface; a “transition region” where differences between the two phases get matched within a layer of a few molecules.

Let us discuss one of the most simple cases; the equilibrium of a pure (single-component) liquid with its vapor. The density of the liquid is so high that molecules are almost closely packed, while in the gas phase, they can freely move at large distances compared to their size.³ Accordingly, molecules in the liquid phase are closely surrounded by their neighbors, while they do not have close neighbors in the vapor. This is illustrated schematically in Fig. 9.1. The real-life picture is of course three-dimensional both in the liquid and the vapor, but a two-dimensional sketch is simpler to show on a surface. Looking at the figure we can state that – in case of a pure substance – molecules are almost closely packed, which would mean 12 neighbors in three dimensions. However, in the surface layer – the edge of the liquid – molecules only have 8 or 9 close neighbors, depending on the actual liquid structure. Even if there is neither a strict structure nor true close packing in liquids, it is certainly true that molecules adjacent to the gas phase have fewer neighbors

³This difference is typical only in states not too close to the critical point.

Fig. 9.1 Schematic representation of a liquid–vapor interface. The bottom part crowded by circles represents the molecules of the liquid phase, the upper part with distant circles those of the vapor phase. It can clearly be seen that more molecules are in the close vicinity of a chosen molecule (five in the case shown) inside the liquid than at the phase boundary (three in the case shown)

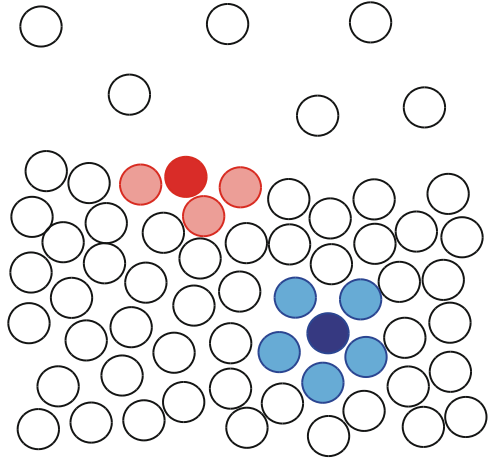

than their counterparts in the liquid. There are attractive interactions between molecules in liquids – this holds them closely packed. Consequently, if we want to move them onto the surface from an inner position, we should “detach” them from some of their neighbors, for what we need to invest energy. If the change in energy associated with the change of the surface is not negligible compared to the energy change of the entire system, we have to include this extra surface energy in the internal energy. This *excess surface energy* of a material compared to the bulk is proportional to the surface, thus we have to write a term proportional to the increment of the surface into the increment of the internal energy, and the surface becomes a variable of the energy function.

Taking into account the excess surface energy in a simple system, the surface A becomes an additional variable in the internal energy function: $U = U(S, V, A, \mathbf{n})$. Its total differential can be written with the appropriate extension of (2.15):

$$\begin{aligned}
 dU = & \left(\frac{\partial U}{\partial S} \right)_{V, A, \mathbf{n}} dS + \left(\frac{\partial U}{\partial V} \right)_{S, A, \mathbf{n}} dV + \left(\frac{\partial U}{\partial A} \right)_{S, V, \mathbf{n}} dA \\
 & + \sum_{i=1}^K \left(\frac{\partial U}{\partial n_i} \right)_{S, V, A, n_{j \neq i}} dn_i.
 \end{aligned} \tag{9.6}$$

The partial derivatives with respect to S , V , and n_i are, as known, the temperature T , the negative pressure $-P$ and the chemical potentials μ_i . The partial derivative with respect to the surface A is called the *surface tension* and we shall denote it by the lower-case Greek letter γ . Accordingly, the differential fundamental equation can be written in the form already provided above:

$$dU = TdS - PdV + \gamma dA + \sum_{i=1}^K \mu_i dn_i. \tag{9.7}$$

We can also deduce the thermodynamic definition of the surface tension in the following form:

$$\gamma(S, V, A, \mathbf{n}) \equiv \left(\frac{\partial U}{\partial A} \right)_{S, V, \mathbf{n}}. \quad (9.8)$$

Furthermore, we can also state that the definitions of the thermodynamic functions $H = U + PV$, $F = U - TS$ and $G = U + PV - TS$ do not change the variables A and n_i , thus the total differentials of these functions given by the fundamental equations $H = H(S, P, A, \mathbf{n})$, $F = F(T, V, A, \mathbf{n})$, and $G = G(T, P, A, \mathbf{n})$ can be written similarly as:

$$dH = TdS + VdP + \gamma dA + \sum_{i=1}^K \mu_i dn_i, \quad (9.9)$$

$$dF = -SdT - PdV + \gamma dA + \sum_{i=1}^K \mu_i dn_i, \quad (9.10)$$

$$dG = -SdT + VdP + \gamma dA + \sum_{i=1}^K \mu_i dn_i. \quad (9.11)$$

The definition of the surface tension can also be written from these latter equations in the following forms:

$$\gamma(S, P, A, \mathbf{n}) = \left(\frac{\partial H}{\partial A} \right)_{S, P, \mathbf{n}}, \quad (9.12)$$

$$\gamma(T, V, A, \mathbf{n}) = \left(\frac{\partial F}{\partial A} \right)_{T, V, \mathbf{n}}, \quad (9.13)$$

$$\gamma(T, P, A, \mathbf{n}) = \left(\frac{\partial G}{\partial A} \right)_{T, P, \mathbf{n}}. \quad (9.14)$$

It is interesting to note that surface tension can also be interpreted by analogy with pressure, which can be considered as the (three-dimensional) force acting on the surface of the system, relative to the surface area. Accordingly, surface tension is the (two-dimensional) force acting on a line within the surface of the system, relative to the length of the line. (There is a basic difference between the two quantities; the pressure P exerts a force to *increase* the volume while the surface tension γ to *decrease* the surface. Accordingly, the respective terms in the total differential of the internal energy function have opposite signs.) It is obvious that the dimensions energy/area and force/length are also identical. We can easily calculate the work done increasing a rectangular surface, e.g. in a slanted rectangular container when we put it into a less slanted position. Increasing the surface along the direction x from position x_0 to x_1 in a container of width b leads to a surface

increment of $bx_1 - bx_0$. The energy increment associated with this surface increment if the composition remains constant is

$$\Delta G = \int_{bx_0}^{bx_1} \gamma dA = \int_{x_0}^{x_1} \gamma b dx. \quad (9.15)$$

This extra energy ΔG has obviously been generated by the work done to increase the surface. This work has been done against a force f along the direction x . Consequently, the same extra energy ΔG can be calculated from this work:

$$\Delta G = \int_{x_0}^{x_1} f dx. \quad (9.16)$$

Comparing the two above equations leads to the equality $\gamma b = f$, or, rearranged, $\gamma = f/b$. This clearly supports that the surface tension can be considered from a mechanical point of view as the force acting *within the surface along a line*, relative to the length of the line. This force tends to *decrease* the surface in case of a liquid–gas (or solid–gas) surface, as the increase of the surface needs the investment of energy. It is worth to note that this force is much easier to measure, and appropriate methods lead to a more accurate value of the surface tension, than measuring energy changes described by (9.8) or (9.14).

The thermodynamic description discussed in the example of Fig. 9.1 is valid for any interface. However, in case of two adjacent condensed phases, molecules are nearly close packed in each of the phases; i.e., the number of neighboring molecules is roughly the same in the interface layer as in the bulk of either phases. Consequently, it is the difference in the attraction of molecules present in the two different phases that will determine which phase has a greater attraction on the molecule in the interface region. Accordingly, the excess surface energy at the boundary of a phase can be either positive or negative. It is also interesting to note that the excess surface energy might be different on different crystal surfaces, as the molecular structure is not necessarily the same at all crystal surfaces. In further discussions, we only deal with liquid–gas surfaces, where the excess surface energy is always positive.

9.1.1 Thermodynamic Properties of Curved Surfaces

According to the above conclusions, in systems of constant entropy and volume – where the minimum of energy is the condition of equilibrium – the liquid of the least possible surface is in equilibrium with the gas phase, as it has the least energy. As the three-dimensional body of minimal surface for a given volume is a sphere, the

equilibrium shape of a liquid system – if the effect of gravitation is negligible – is spherical. (A liquid body of large mass is deformed by gravitation; thus, a large liquid drop on a flat surface has a flattened shape. However, if a liquid droplet is small enough, its shape is really spherical. Lack of gravitation – e.g., in the state of weightlessness – leads to spherical shape even for larger drops. If the liquid has an interface with other liquids or solids, surface energetics is different, thus the shape is usually no more spherical. This latter effect is called *wetting* what we do not discuss here.)

Let us examine the equilibrium between the liquid and gas phase in case of a pure (single-component) liquid, taking into account the excess surface energy. Consider as one of the two subsystems the liquid with the spherical surface; the other is the gas phase in contact with the liquid. Let us discuss first the example of a small droplet whose spherical shape is not distorted by gravitation, in equilibrium with its vapor. The droplet and the saturated vapor are enclosed in a constant-temperature rigid container in an arrangement shown schematically in Fig. 9.2.

As both volume and amount are constant within the container, the equalities – $dV^g = dV^l$ and $-dn^g = dn^l$ hold. Temperature cannot change in the thermostatted system, thus $dT^g = dT^l = 0$. The condition of equilibrium in a system of constant volume, temperature and amount is the minimum of the free energy function, which can be written as the mathematical condition $dF = 0$. In the total differential of $F = F^g(T^g, V^g, n^g) + F^l(T^l, V^l, A^l, n^l)$, the term containing the derivative with respect to T multiplied by the increment dT is zero, as the temperature is constant. The resulting equation for the equilibrium condition can be written with the respective intensive variables substituted for the partial derivatives. According to the figure, P_{in} denotes the pressure inside the drop, while P_{ex} the pressure in the gas phase:

$$dF = -P_{ex}dV^g + \mu^g dn^g - P_{in}dV^l + \gamma^l dA^l + \mu^l dn^l = 0. \tag{9.17}$$

Making use of the equalities $-dV^g = dV^l$ and $-dn^g = dn^l$, and regrouping terms we get:

$$dF = (P_{ex} - P_{in})dV^l + (\mu^l - \mu^g)dn^l + \gamma^l dA^l = 0. \tag{9.18}$$

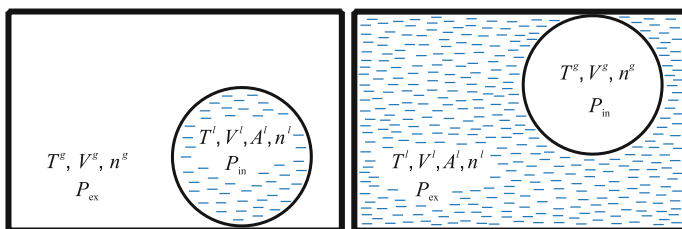

Fig. 9.2 Schematic representation of the equilibrium of spherical liquid–gas interfaces. A liquid drop is shown on the left-hand side, and a bubble or cavity on the right-hand side. Both containers (thick *rectangular boxes*) have rigid, impermeable walls and are immersed into a thermostat (have a constant temperature)

Molecules of the liquid can freely move between the two phases, thus the intensive condition of the equilibrium is the equality of the chemical potentials μ^l and μ^g , from which it follows that $(\mu^l - \mu^g) dn^l = 0$. The resulting equation reads as:

$$(P_{\text{ex}} - P_{\text{in}})dV^l + \gamma^l dA^l = 0. \quad (9.19)$$

Let us calculate the relationship between the curvature of the liquid surface and the pressure inside the spherical drop. The curvature of the sphere can be characterized by its radius r . In case of a sphere of radius r , the increment of both the surface and the volume can be given by the increment of the radius dr . To calculate this increment, let us first express the second and third power of $r + dr$.

$$(r + dr)^3 = r^3 + 3r^2 dr + 3r(dr)^2 + (dr)^3 \cong r^3 + 3r^2 dr, \quad (9.20)$$

$$(r + dr)^2 = r^2 + 2r dr + (dr)^2 \cong r^2 + 2r dr. \quad (9.21)$$

(We have made use of the fact that the second and third power of the infinitesimally small quantity dr can be neglected compared to the other two terms remaining.) Using the above results, we can write:

$$dV = (V + dV) - V = \frac{4(r + dr)^3 \pi}{3} - \frac{4r^3 \pi}{3} \cong 4r^2 \pi dr, \quad (9.22)$$

$$dA = (A + dA) - A = 4(r + dr)^2 \pi - 4r^2 \pi \cong 8r \pi dr. \quad (9.23)$$

Let us substitute the above results for the increments dV and dA into (9.19), and rearrange the equation:

$$-(P_{\text{ex}} - P_{\text{in}}) \cdot 4r^2 \pi dr = \gamma \cdot 8r \pi dr \quad (9.24)$$

This equation should hold for any value of dr (equivalently, we can “simplify” by dr), thus we can express the equilibrium pressure within the drop as:

$$P_{\text{in}}(\text{drop}) = P_{\text{ex}} + \frac{2\gamma}{r}. \quad (9.25)$$

In case of a spherical bubble, equilibrium calculations are quite similar. The only difference is that the liquid surface is *not convex but concave* in this case, i.e., its curvature is not positive but negative. As a consequence, we get the result for the equilibrium pressure *inside a bubble* by simply replacing $1/r$ by $-1/r$ in the above equation:

$$P_{\text{in}}(\text{bubble}) = P_{\text{ex}} - \frac{2\gamma}{r}. \quad (9.26)$$

We can see from the results that the pressure inside a drop is greater than in the surrounding gas phase, while it is smaller in a bubble than in the surrounding liquid phase.

Equations (9.25) and (9.26) describe the pressure within spherically curved liquid surfaces. The general form of the equation for any shape is the Young–Laplace equation:

$$P_{\text{in}} = P_{\text{ex}} + \gamma \left(\frac{1}{r_1} + \frac{1}{r_2} \right). \quad (9.27)$$

Here, r_1 and r_2 are the so-called *principal radii of curvature* at a given point of the surface. In case of a sphere, these are identical, thus we get back the term $2\gamma/r$. Based on (9.25)–(9.27), we can also state that the pressure inside a liquid of flat surface is identical to the pressure of the adjacent gas phase, as $r = \infty$ in this case. The difference of the inner pressure of droplets or bubbles from the gas phase in equilibrium with a flat surface is proportional to the surface tension, and inversely proportional to the radius of the droplet. Thus, the smaller the size of droplets or bubbles, the greater is the difference in pressure.

Curved liquid surfaces occur not only in drops or bubbles. It is well known that in thin tubes called *capillaries* the liquid surface is not flat but curved, and the liquid level is either above or below the flat level outside the capillary. In the light of the Young–Laplace equation, it is obvious that the two effects are related; the pressure inside the capillary at the curved surface is different from that of a flat surface. The direction of the curving depends on the interactions between the solid tubing material and the liquid inside. If the interaction between the molecules of the solid and those of the liquid (*adhesion*) is more attractive than the interaction between the molecules of the liquid (*cohesion*), the liquid *wets* the capillary surface and creeps up the wall. If adhesion is weaker than cohesion, the liquid does not wet the capillary surface and descends the wall. The Young–Laplace equation enables to calculate the capillary rise (or descent) from the curvature of the liquid surface. To perform the calculations, let us consider the cases shown in Fig. 9.3.

Let us suppose that wetting is strong enough (or weak enough in case of a non-wetting liquid) and the diameter of the capillary is small enough for the liquid to

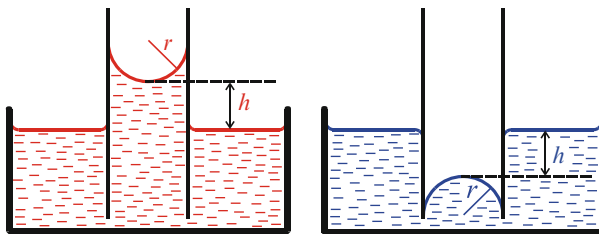

Fig. 9.3 The surface, curvature and height of the liquid in a capillary tube. The liquid wets the surface of the capillary on the left-hand side and does not wet it on the right-hand side

form an undistorted hemispherical surface. In this case, the radius r of the surface (called *meniscus*⁴) is the same as that of the capillary tube, and (9.25) or (9.26) can be used to calculate the pressure at the curved surface in the liquid.⁵ If the liquid wets the tube (e.g., water in a glass tube) the surface inside the liquid is concave, thus its pressure is lower than the external pressure P by $2\gamma/r$. As a consequence, the liquid *rises* in the capillary tube until a height h where the hydrostatic pressure decreases the pressure at the liquid surface to P , thus maintaining hydrostatic equilibrium within the liquid:

$$\rho gh = \frac{2\gamma}{r}. \quad (9.28)$$

(The lower-case Greek letter ρ denotes the density of the liquid, while g the gravitational acceleration.) From this equation, we can express the *capillary rise*:

$$h = \frac{2\gamma}{\rho gr}. \quad (9.29)$$

If the liquid does not wet the tube (e.g., mercury in a glass tube) the surface inside the liquid is convex, thus its pressure is *higher* than the external pressure P by $2\gamma/r$. As a consequence, the meniscus *falls* in the capillary tube until the hydrostatic equilibrium is achieved within the liquid. The *capillary depression* h is also described by (9.29).

Capillary action has a great role in the transport through porous materials. This is the reason that sponges absorb a considerable amount of water. Water uptake of plants from the soil is also partly due to capillary action, partly to osmosis, already discussed in this book.

Above curved surfaces, the equilibrium vapor pressure is also different compared to the vapor above flat surfaces. The reason for this is that, in addition to the mechanical equilibrium described by (9.25) or (9.26), chemical equilibrium between the liquid and the vapor should also hold. The condition of this equilibrium is the equality of the chemical potentials in both phases. Let us write the condition of the two equilibria in case of a drop of radius r , using the subscripts v for vapor and l for liquid:

$$P^l - P^v = \frac{2\gamma}{r}, \quad (9.30)$$

$$\mu^l(T, P^l) = \mu^v(T, P^v). \quad (9.31)$$

⁴The word makes allusion to the shape of the crescent Moon. The diminutive form $\mu\eta\eta\sigma\kappa\omicron\varsigma$ of the Greek word $\mu\eta\eta\eta$ (a name for the Moon) means the waning crescent. (It survived in the Latin name *mensis* meaning a month.)

⁵If the conditions mentioned are not fulfilled, i.e., the surface is not hemispherical, the pressure acting on the surface can be evaluated as a consequence of the mechanical equilibrium taking into account the actual geometry of the surface. This is the case if wetting is weak, or if the surface is flatter than spherical in a thicker tube.

In the second equation, $\mu^l(T, P^l)$ is the chemical potential of the liquid at the equilibrium temperature T and the equilibrium pressure P^l inside the drop, while $\mu^v(T, P^v)$ is the chemical potential of the vapor at the same temperature T and the pressure of the vapor phase P^v . The equilibrium should hold for an infinitesimal change of the pressure as well:

$$P^l + dP^l - (P^v + dP^v) = \frac{2\gamma}{r} + d\left(\frac{2\gamma}{r}\right), \quad (9.32)$$

$$\mu^l(T, P^l) + d\mu^l = \mu^v(T, P^v) + d\mu^v. \quad (9.33)$$

Accordingly, equilibrium is only maintained if both equalities

$$dP^l - dP^v = d\left(\frac{2\gamma}{r}\right). \quad (9.34)$$

and

$$d\mu^l = d\mu^v \quad (9.35)$$

holds. Note that the equilibrium is described similarly to the phase equilibrium discussed in Sect. 7.2.3, adding the condition of mechanical equilibrium. Thus, we can use (6.13) to express the total differential of the chemical potential in terms of the increments of temperature and pressure. At constant temperature, the term containing dT is zero, so it can be dropped. The term containing dx can also be dropped as we deal with a pure substance, i.e., x is always unit. Let us denote the molar volumes of the corresponding phases in the surviving term by v^l and v^v . Thus, (9.35) can be rewritten as:

$$v^l dP^l = v^v dP^v. \quad (9.36)$$

Let us substitute dP^l as expressed from (9.34):

$$v^l dP^v + v^l d\left(\frac{2\gamma}{r}\right) = v^v dP^v. \quad (9.37)$$

Rearranging we get:

$$d\left(\frac{2\gamma}{r}\right) = \frac{v^v - v^l}{v^l} dP^v \quad (9.38)$$

Taking into account that the molar volume of the liquid v^l is negligible compared to that of the vapor v^v , the ratio $(v^v - v^l)/v^l$ can be replaced by v^v/v^l . Supposing that the vapor behaves as an ideal gas, we can substitute RT/P^v for the molar volume v^l :

$$d\left(\frac{2\gamma}{r}\right) = \frac{RT}{v^l} \frac{1}{P^v} dP^v. \quad (9.39)$$

To calculate the excess vapor pressure, let us integrate the left side from $r = \infty$ (flat surface) to the actual drop radius r , and the right side from the pressure P_0 over the flat surface to P_r , the equilibrium pressure over the surface of the drop. (While doing so, it is reasonable to change the integration variable from r to s .)

$$\int_{s=\infty}^{s=r} d\left(\frac{2\gamma}{s}\right) = \frac{RT}{v^l} \int_{P^v=P_0}^{P^v=P_r} \frac{1}{P^v} dP^v. \quad (9.40)$$

Integrating we obtain the result

$$\frac{2\gamma}{r} = \frac{RT}{v^l} \ln \frac{P_r}{P_0}, \quad (9.41)$$

which is readily rearranged to provide the vapor pressure in equilibrium with the liquid surface of a drop of radius r :

$$P_r(\text{drop}) = P_0 e^{\frac{2\gamma v^l}{RT r}}. \quad (9.42)$$

It is convenient to write the molar volume v^l as the ratio of the molar mass M and the density ρ :

$$P_r(\text{drop}) = P_0 e^{\frac{2\gamma M}{RT r \rho}}. \quad (9.43)$$

Both equations are usually called as the *Kelvin equation* for spherical drops. (The general form of the Kelvin equation is also given in terms of the two principal radii of curvature; cf. (9.27).)

In case of a spherical bubble, equilibrium calculations are quite similar. The only difference is that the convex curvature $1/r$ should be replaced by the concave curvature $-1/r$ to get the equilibrium vapor pressure inside a *bubble*:

$$P_r(\text{bubble}) = P_0 e^{-\frac{2\gamma M}{RT r \rho}}. \quad (9.44)$$

Let us recall the two approximations used to get the above expressions; the molar volume of the liquid has been ignored in the difference $v^v - v^l$, and the vapor was supposed to be an ideal gas. To have an idea of the first approximation, consider the molar volume 18 cm^3 of liquid water at 25°C compared to that of the vapor in equilibrium with it at 3.169 kPa being $780\,480 \text{ cm}^3$. Thus, the difference arising from substituting v^v/v^l in place of $(v^v - v^l)/v^l$ is merely 0.0024% . The molar volume of an ideal gas at the same temperature and pressure is $782\,253 \text{ cm}^3$, leading to a difference of 0.227% only. The overall difference thus does not exceed 0.23% . The difference diminishes with decreasing temperature but increases with increasing temperature, mainly due to the ideal gas approximation, but even at 100°C , it is

only 1.68%. Thus, it is not worth using (9.38) and the exact pressure-dependent v'' and v' but (9.43) when making only approximate calculations.

The effect of the change of vapor pressure according to (9.43) and (9.44) over curved surfaces has important consequences. One of them is the *isothermal distillation* of liquids when smaller droplets having greater vapor pressure get vaporized while the vapor condenses onto the greater droplets. Thus, greater droplets get growing and smaller droplets get reduced in size – as it happens in clouds. In a saturated vapor, the formation of the first droplets is hindered by the fact that the vapor pressure in equilibrium with these droplets is larger than the equilibrium pressure over a flat surface, or even larger droplets. Consequently, stable droplets can only be formed from a supersaturated vapor, thus condensation begins at higher than the equilibrium pressure. This supersaturation does not occur if there are solid particles present in the gas phase; on their surface, there is a possibility to form a liquid layer of greater radius. Contrails (or vapor trails) in the wake of aircrafts also develop by condensation on the soot particles emanating from the exhaust of the engine.

In a similar manner, boiling inside liquids is also hindered by the fact that the pressure inside the small bubbles to form at the beginning of boiling is smaller than the outer pressure above the flat liquid surface. Accordingly, small bubbles can only be formed at higher vapor pressure – thus at higher temperature – leading to the superheating of the liquid. (To avoid superheating, boiling chips are used, containing relatively large cavities to help evaporation.)

The equilibrium of small crystallites with a saturated solution can be described similarly to the case of droplets and their vapor. In this case, the solubility of small crystallites is greater than that of greater size crystals. From this, it follows that solutions get typically oversaturated before crystallization, as the solution saturated for large crystals is still undersaturated for the first-to-appear small crystallites.

9.2 Thermodynamic Description of Systems Containing Electrically Charged Particles

Systems containing electrically charged particles have two interesting and important properties in addition to the formal description provided by (9.3) shown at the beginning of this chapter. One of these properties is that there exists no electric charge without a *charge carrier*, which is a molecular entity. Within earthly conditions, such a charge carrier can be the *electron* or *ions*. The charge of individual ions can be the multiple of either the charge of an electron (these are the *negatively charged ions*) or the multiple of the charge of a proton (these are the *positively charged ions*). The charge of the electron and that of the proton has equal absolute values but opposite sign. The charge of the proton is called the *elementary charge*, and its value is $1.602176487 \times 10^{-19}\text{C}$. Accordingly, 1C is 6.24151×10^{18} elementary particles. However, in chemistry we do not use this

value but the macroscopic quantity of 1 mol elementary charges as a unit. This unit is the product of the elementary charge and the Avogadro constant:

$$\begin{aligned} 1F &= 1.602176487 \times 10^{-19} \text{ C} \cdot 6.02214179 \times 10^{23} \text{ mol}^{-1} \\ &= 96485.33977 \text{ Cmol}^{-1} \end{aligned} \quad (9.45)$$

The quantity F is called the *Faraday constant*.⁶

The charge of ions is characterized by their *charge number*, which is the number of elementary charges carried by a single ion. Accordingly, the charge number of an Na^+ ion is $+1$, that of the Cl^- ion is -1 , that of the Al^{+3} ion is $+3$, and that of the ion SO_4^{2-} is -2 . The charge number of the common charge carrier electron (which is not considered as an ion) is -1 . It is important to note that the property of electric charge being always connected to a charge carrier particle implies that to change the quantity of charge is always connected to moving particles, as there is no electric charge without a carrier particle.⁷

Another important property of systems containing electrically charged particles is the *electroneutrality principle*. According to this, the sum of the absolute value of the negative and the positive charges is always equal, thus macroscopic systems are always *electrically neutral*. We have learnt in electrostatics that electrically charged macroscopic bodies do exist, so this principle needs some considerations. Let us imagine a spherical piece of aluminum containing exactly 1 mol atoms. The density of aluminium is 2.700 g cm^{-3} , its molar mass is $26.9815 \text{ g mol}^{-1}$, whence its molar volume is $9.99315 \text{ cm}^3 \text{ mol}^{-1}$, thus the radius of the sphere is 1.3362 cm. If the sphere is electrically neutral, it contains 0 charge and we can measure a voltage of 0 V on its surface with respect to earth potential. Let us calculate the potential of the same size aluminum sphere if we “withdraw” $3 \times 10^{-10} \text{ mol}$ electrons, thus creating 10^{-10} mol Al^{3+} ions, which means a positive excess charge of $3 \times 10^{-10} F$. The potential of a conducting sphere in vacuum having an excess charge Q can be calculated as:

$$E = \frac{Q}{4\pi\epsilon_0 r}. \quad (9.46)$$

⁶Michael Faraday (1791–1867) was an English chemist and physicist. His most important achievements are in the field of electrochemistry and electromagnetism. He discovered the laws named after him, stating that the transport of a given amount of substance always means the transport of a well-determined amount of electric charge. The unit of capacity, *farad* is also named after him. (Not to be confused with the chemical unit of charge, *faraday*.)

⁷The person who laid down the principles of electric theory is the American inventor, scientist and politician Benjamin Franklin (1706–1790). He imagined electricity – similarly to heat – as a liquid. According to his interpretation, the charge of bodies containing a lot of electric fluid is “positive” (or “vitreous” using an elder name, as this property occurs when rubbing glass), while the charge of bodies containing little electric fluid is “negative” (or “resinous” using an elder name, as this property occurs when rubbing amber). The movement of the liquid is the electric current. This interpretation still survives in the theory of electricity, where charge carriers are not considered but “the quantity of electric charge”.

Substituting the charge $3 \times 10^{-10} F = 3 \times 9.64853 \times 10^{-19} C$, the vacuum permittivity $\epsilon_0 = 8.854187817 \times 10^{-12} F m^{-1}$, the radius $r = 0.013362 m$, we get the potential $19\,469\,408 V$ for the sphere. It means that, in case of 1 mol aluminum, 1×10^{-10} mol free Al^{3+} ions provide a voltage of nearly 20 million V with respect to earth. This quantity of ions in 1 mol is 0.0001 millionths of a mol, or in analytical terms, 0.1 ppb, which is chemically undetectable.⁸ (It means that the neutral sphere cannot be distinguished by *chemical methods* from the one at 20 million V potential.) It is obvious that such high potentials cannot be treated in the chemical laboratory. However, they cannot occur either; as the discharge across the air to the nearest neutral object (at earth potential) would radically diminish this potential. It is also obvious that in case of smaller potentials, the associated charges are also smaller, thus their chemical detectability is even more impossible. The voltage of usual electrochemical devices does not exceed 10 V, which is equivalent to approximately 1.5×10^{-16} mol free Al^{3+} ions. The distinction between the charged and the neutral sphere is completely impossible with any chemical methods in this case.

Based on the above considerations, we can conclude that we cannot make any chemical difference between a neutral and a charged system. Thus, we always accept the validity of the electroneutrality principle – even if our system is electrically charged. Let us formulate the principle from the thermodynamical point of view. Consider a system of K components, out of which J are ionic components. The amount of components be n_i and their charge number z_i . The system is electrically neutral if

$$\sum_{i=1}^J n_i z_i = 0 \quad (9.47)$$

holds. Dividing the above equation by the volume of the system or the mass of the solvent, we get two equivalent equations in terms of molar concentrations c_i or molalities m_i :

$$\sum_{i=1}^J c_i z_i = 0; \quad \sum_{i=1}^J m_i z_i = 0. \quad (9.48)$$

Any one of the three equations expresses the principle of electroneutrality, thus we can use any of them for the thermodynamic description.

The electroneutrality principle imposes a constraint for the ionic components, which is not needed if the system contains only electrically neutral particles. This constraint results in a reduction of the number of degrees of freedom by one, even if there is no electric field present; i.e., the number of degrees of freedom is only $K + F - 1$ instead of $K + F - 2$ if the system contains ionic species as well.

⁸The unit ppb is the acronym of “parts per billion”. The ratio 0.1 ppb is roughly equivalent to one person over the entire population of Earth.

9.2.1 Thermodynamic Consequences of the Electroneutrality Principle: The Chemical Potential of Electrolytes and the Mean Activity Coefficient

An important consequence of the electroneutrality principle is that the chemical potential of individual ions cannot be determined. To demonstrate this, let us recall the expression of the chemical potential as a function of temperature, pressure and composition already stated in (6.8):

$$\mu_i(T, P, x_1, x_2, \dots, x_K) = \left(\frac{\partial G}{\partial n_i} \right)_{T, P, n_j \neq i} .$$

Obviously, to calculate the chemical potentials, we have to know the Gibbs potential as a function of the amount n_i of every components. This function should be measured, or calculated from related measured data. To do this measurement, we should change *the amount of a single ion* independently of other ions. However, this is impossible, as the electroneutrality principle only allows changes of the amounts of ions which fulfill (9.47).

Fortunately, we do not need the knowledge of the chemical potential of individual ions either to describe equilibria of systems containing ionic species – which is also the consequence of the electroneutrality principle. As an example, let us discuss a system where a substance dissociating to produce ions – say, AlCl_3 – distributes between two phases α and β . The condition of equilibrium at constant temperature and pressure – as stated in (8.5) – can be written as:

$$\mu_{\text{Al}^{3+}}^\alpha dn_{\text{Al}^{3+}}^\alpha + \mu_{\text{Cl}^-}^\alpha dn_{\text{Cl}^-}^\alpha + \mu_{\text{Al}^{3+}}^\beta dn_{\text{Al}^{3+}}^\beta + \mu_{\text{Cl}^-}^\beta dn_{\text{Cl}^-}^\beta = 0. \quad (9.49)$$

As we do not consider chemical reactions, the amount of the species can only change by transfer across the phase boundary, hence we can write $dn_{\text{Al}^{3+}}^\alpha = -dn_{\text{Al}^{3+}}^\beta$ and $dn_{\text{Cl}^-}^\alpha = -dn_{\text{Cl}^-}^\beta$. Substituting these into the above equation and rearranging, we get:

$$\left(\mu_{\text{Al}^{3+}}^\alpha - \mu_{\text{Al}^{3+}}^\beta \right) dn_{\text{Al}^{3+}}^\alpha + \left(\mu_{\text{Cl}^-}^\alpha - \mu_{\text{Cl}^-}^\beta \right) dn_{\text{Cl}^-}^\alpha = 0. \quad (9.50)$$

The electroneutrality principle can be written in the following form:

$$z_{\text{Al}^{3+}} n_{\text{Al}^{3+}}^\alpha + z_{\text{Cl}^-} n_{\text{Cl}^-}^\alpha = 0. \quad (9.51)$$

This principle is valid also if there is a transfer of the ions from one phase to the other, from which it follows:

$$z_{\text{Al}^{3+}} dn_{\text{Al}^{3+}}^\alpha - z_{\text{Cl}^-} dn_{\text{Cl}^-}^\alpha = 0. \quad (9.52)$$

As the ions are formed by dissociation of the AlCl_3 , between the quantities $n_{\text{Al}^{3+}}^\alpha$ and $n_{\text{Cl}^-}^\alpha$, as well as between $dn_{\text{Al}^{3+}}^\alpha$ and $dn_{\text{Cl}^-}^\alpha$, the conditions arising from the stoichiometric equation should also be fulfilled. The stoichiometric equation can be written as:

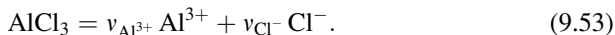

(A reasonable choice is of course $\nu_{\text{Al}^{3+}} = 1$ and $\nu_{\text{Cl}^-} = 3$.) Thus, the conditions following from the dissociation can be written as

$$n_{\text{Al}^{3+}}^\alpha = \nu_{\text{Al}^{3+}} n_{\text{AlCl}_3}^\alpha \quad \text{and} \quad n_{\text{Cl}^-}^\alpha = \nu_{\text{Cl}^-} n_{\text{AlCl}_3}^\alpha , \quad (9.54)$$

as well as

$$dn_{\text{Al}^{3+}}^\beta = \nu_{\text{Al}^{3+}} dn_{\text{AlCl}_3}^\beta \quad \text{and} \quad dn_{\text{Cl}^-}^\beta = \nu_{\text{Cl}^-} dn_{\text{AlCl}_3}^\beta . \quad (9.55)$$

Using the latter two equations, the condition in (9.50) can be written in the following form:

$$\nu_{\text{Al}^{3+}} \left(\mu_{\text{Al}^{3+}}^\alpha - \mu_{\text{Al}^{3+}}^\beta \right) dn_{\text{AlCl}_3}^\alpha + \nu_{\text{Cl}^-} \left(\mu_{\text{Cl}^-}^\alpha - \mu_{\text{Cl}^-}^\beta \right) dn_{\text{AlCl}_3}^\alpha = 0 . \quad (9.56)$$

This equation should hold for arbitrary $dn_{\text{AlCl}_3}^\alpha$, thus

$$\nu_{\text{Al}^{3+}} \left(\mu_{\text{Al}^{3+}}^\alpha - \mu_{\text{Al}^{3+}}^\beta \right) + \nu_{\text{Cl}^-} \left(\mu_{\text{Cl}^-}^\alpha - \mu_{\text{Cl}^-}^\beta \right) = 0 . \quad (9.57)$$

Upon rearrangement, this yields the following result:

$$\nu_{\text{Al}^{3+}} \mu_{\text{Al}^{3+}}^\alpha + \nu_{\text{Cl}^-} \mu_{\text{Cl}^-}^\alpha = \nu_{\text{Al}^{3+}} \mu_{\text{Al}^{3+}}^\beta + \nu_{\text{Cl}^-} \mu_{\text{Cl}^-}^\beta . \quad (9.58)$$

The meaning of this result is more obvious after substituting the stoichiometric numbers:

$$\mu_{\text{Al}^{3+}}^\alpha + 3\mu_{\text{Cl}^-}^\alpha = \mu_{\text{Al}^{3+}}^\beta + 3\mu_{\text{Cl}^-}^\beta \quad (9.59)$$

From the above discussion, we can conclude that in case of electrolytes (which dissociate into ionic species), we do not need to know the chemical potential of the individual ions to characterize the equilibrium state; it is sufficient to know the chemical potential of the neutral combination of anions and cations. If the melt or solution containing the ions is in equilibrium with the solid electrolyte, this combination should be equal to the chemical potential of the solid. For this reason, the neutral combination can be called the *chemical potential of the electrolyte*. In the above example, this can be written as:

$$\mu_{\text{Al}^{3+}} + 3\mu_{\text{Cl}^-} = \mu_{\text{AlCl}_3} \quad (9.60)$$

Note that the term “electrolyte” in this respect should be interpreted in a general sense; it designates the neutral combination of oppositely charged species of any system where these charged species can move. Thus, the above considerations are equally valid, e.g., for metals or metal oxides. In metals, the equilibrium is determined by the combination of the chemical potentials of metal cations and electrons, while in metal oxides, by those of the metal cations and the oxygen ions.

We can generalize the conclusions of the example. Using a general notation for the electrolyte $C_{v_+}A_{v_-}$, which dissociates to $v_+C^{z_+}$ cations and $v_-A^{z_-}$ anions, we can write the dissociation as:

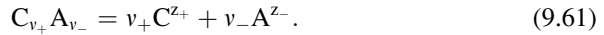

The number of charges should be the same (in this case, zero) on both sides of the equation, thus the electroneutrality can be written in terms of the stoichiometric numbers:

$$v_+z_+ + v_-z_- = 0. \quad (9.62)$$

To describe the equilibrium, it is sufficient to know the chemical potential of the electrolyte:

$$\mu_{C_{v_+}A_{v_-}} = v_+\mu_{C^{z_+}} + v_-\mu_{A^{z_-}}. \quad (9.63)$$

It is important to add that the *difference* of the chemical potential of individual ions is well defined. This can be illustrated by the following example. Let us write (9.63) for aluminum-chloride and aluminum-nitrate:

$$\mu_{Al^{3+}} + 3\mu_{Cl^-} = \mu_{AlCl_3}, \quad (9.64)$$

$$\mu_{Al^{3+}} + 3\mu_{NO_3^-} = \mu_{AlNO_3}. \quad (9.65)$$

Dividing the difference of the two equations by 3, we get the result

$$\mu_{Cl^-} - \mu_{NO_3^-} = \frac{1}{3}(\mu_{AlCl_3} - \mu_{AlNO_3}), \quad (9.66)$$

which is well determined, as the right-hand side of the equation contains the difference of two well-determined (and measurable) chemical potentials. Similarly, we can calculate the difference of the following two equations:

$$\mu_{Zn^{2+}} + 2\mu_{Cl^-} = \mu_{ZnCl_2}, \quad (9.67)$$

$$\mu_{Ca^{2+}} + 2\mu_{Cl^-} = \mu_{CaCl_2}, \quad (9.68)$$

to get the well-determined difference

$$\mu_{\text{Zn}^{2+}} - \mu_{\text{Ca}^{2+}} = \frac{1}{2} (\mu_{\text{ZnCl}_2} - \mu_{\text{CaCl}_2}). \quad (9.69)$$

Let us examine the consequences of the above discussions for the *activity* of individual ionic species. According to (6.70), the absolute activity λ_i of a species i can be expressed with the help of its chemical potential:

$$\mu_i = RT \ln \lambda_i.$$

Applying this relation to each term in (9.63), we can write:

$$RT \ln \lambda_{\text{C}_{v_+} \text{A}_{v_-}} = RT v_+ \ln \lambda_{\text{C}^{z_+}} + RT v_- \ln \lambda_{\text{A}^{z_-}}. \quad (9.70)$$

Let us divide the equation by RT , rewrite the multiplication of the logarithms as the power of the arguments and the sum of the logarithms as the logarithm of the product of the arguments:

$$\ln \lambda_{\text{C}_{v_+} \text{A}_{v_-}} = \ln [(\lambda_{\text{C}^{z_+}})^{v_+} (\lambda_{\text{A}^{z_-}})^{v_-}] \quad (9.71)$$

Inverting the logarithm, we obtain the thermodynamically sound activity of the electrolyte $\text{C}_{v_+} \text{A}_{v_-}$ as the product in the above equation:

$$\lambda_{\text{C}_{v_+} \text{A}_{v_-}} = (\lambda_{\text{C}^{z_+}})^{v_+} (\lambda_{\text{A}^{z_-}})^{v_-}. \quad (9.72)$$

Denoting the number of ions produced upon the dissociation of the electrolyte $\text{C}_{v_+} \text{A}_{v_-}$ by $v = v_+ + v_-$, we can interpret the mean absolute activity of one of them from the following equation:

$$(\lambda_{v_+ \text{C}^{z_+}, v_- \text{A}^{z_-}})^v = (\lambda_{\text{C}^{z_+}})^{v_+} (\lambda_{\text{A}^{z_-}})^{v_-}. \quad (9.73)$$

From this, we can express the *mean absolute activity* related to a single ion as the *geometric mean* of the activities of individual ions:

$$\lambda_{v_+ \text{C}^{z_+}, v_- \text{A}^{z_-}} = \sqrt[v]{(\lambda_{\text{C}^{z_+}})^{v_+} (\lambda_{\text{A}^{z_-}})^{v_-}} \quad (9.74)$$

We can interpret this definition as an equal redistribution of the activity of the electrolyte among the ions formed during dissociation.

As the notation is considerably complex in the above definition, it is common practice to use a simplified notation. If anions and cations are well defined, it is sufficient to write λ_+ and λ_- instead of $\lambda_{\text{C}^{z_+}}$ and $\lambda_{\text{A}^{z_-}}$, and λ_{\pm} instead of $\lambda_{v_+ \text{C}^{z_+}, v_- \text{A}^{z_-}}$. Thus, the simplified definition of the mean activity can be written as:

$$\lambda_{\pm} = \sqrt[v]{(\lambda_+)^{v_+} (\lambda_-)^{v_-}}. \quad (9.75)$$

In mixtures containing charged particles, interactions between the ions are determined by long-range electrostatic interactions, thus they cannot be treated as ideal mixtures even in case of considerably dilute solutions. Let us write the mean activity for the standard state of a real mixture:

$$\lambda_{\pm}^{\ominus} = \sqrt[v]{(\lambda_{+}^{\ominus})^{v_{+}} (\lambda_{-}^{\ominus})^{v_{-}}}. \quad (9.76)$$

In analogy with (6.71), we can write

$$\mu_{\pm} - \mu_{\pm}^{\ominus} = RT \ln \frac{\lambda_{\pm}}{\lambda_{\pm}^{\ominus}}. \quad (9.77)$$

The argument of the logarithm is the *mean relative activity* a_{\pm} which is simply called as *mean activity* in the chemical praxis. The ratio can be expressed in terms of the relative activities of the individual ions:

$$a_{\pm} = \frac{\lambda_{\pm}}{\lambda_{\pm}^{\ominus}} = \sqrt[v]{\frac{(\lambda_{+})^{v_{+}} (\lambda_{-})^{v_{-}}}{(\lambda_{+}^{\ominus})^{v_{+}} (\lambda_{-}^{\ominus})^{v_{-}}}} = \sqrt[v]{\frac{(\lambda_{+})^{v_{+}}}{(\lambda_{+}^{\ominus})^{v_{+}}} \frac{(\lambda_{-})^{v_{-}}}{(\lambda_{-}^{\ominus})^{v_{-}}}} = \sqrt[v]{(a_{+})^{v_{+}} (a_{-})^{v_{-}}}. \quad (9.78)$$

From the last two equations, we can express the *mean chemical potential* μ_{\pm} of the electrolyte:

$$\mu_{\pm} = \mu_{\pm}^{\ominus} + RT \ln a_{\pm}. \quad (9.79)$$

The practical choice in electrochemistry is to refer the standard chemical potential μ_{\pm}^{\ominus} to the molality m_{\pm} in the following sense. Writing the relative activity as a function of molality according to (6.92), we get:

$$\mu_{\pm} = \mu_{m_{\pm}}^{\ominus} + RT \ln \gamma_{m_{\pm}} \left(\frac{m_{\pm}}{m_{\pm}^{\ominus}} \right). \quad (9.80)$$

Let us simplify this notation by dropping the subscripts m , and assign to the symbol m_{\pm} the molality divided by the standard molality m_{\pm}^{\ominus} , i.e., the measured value in units of the standard molality. As a result, we get the commonly used expression of the mean chemical potential:

$$\mu_{\pm} = \mu_{\pm}^{\ominus} + RT \ln \gamma_{\pm} m_{\pm}. \quad (9.81)$$

In this expression, m_{\pm} is the mean chemical potential of any one of the ionic species formed from the electrolyte, and the standard potential μ_{\pm}^{\ominus} refers to the (hypothetical) state of this ion in which the activity $a_{\pm} = \gamma_{\pm} m_{\pm}$ is unit.

In accordance with the reasoning in Sect. 6.3.3, it is practical to reference the standard state to the infinitely dilute solution:

$$\lim_{m_{\pm} \rightarrow 0} \gamma_{\pm} = 1. \quad (9.82)$$

In this case, the standard refers to the hypothetical concentration of $m_{\pm} = 1 \text{ mol kg}^{-1}$ of molecules in the infinitely dilute state.

We can summarize the results the following way. Substances dissociating to yield ions in a solution or melt are called electrolytes. The chemical potential or the activity of individual ions thus formed cannot be determined, but it is not necessary to know them either to characterize thermodynamic equilibria of ionic systems. Instead, we need to know only the chemical potential or the activity of the neutral combination of ions corresponding to the composition of the electrolyte to characterize equilibrium, which can be determined. In case of an electrolyte dissociating into v_+ cations and v_- anions, this chemical potential is defined as:

$$\mu_{\pm} = v_+ \mu_+ + v_- \mu_-. \quad (9.83)$$

Accordingly, the individual chemical potentials μ_+ and μ_- are only determined up to an arbitrary additive constant. In other words, only their difference is uniquely determined.

The *mean (relative) activity* associated to one single ion out of the $v = v_+ + v_-$ ions formed from the electrolyte upon dissociation can also be derived from the individual ionic activities according to the following formula:

$$a_{\pm} = \sqrt[v]{(a_+)^{v_+} (a_-)^{v_-}}. \quad (9.84)$$

Consequently, the individual activities a_+ and a_- are only determined up to an arbitrary multiplicative constant. In other words, only their ratio is uniquely determined. If the individual ionic activities a_+ and a_- are expressed in terms of molalities, then the mean activity a_{\pm} can be decomposed the following way:

$$\begin{aligned} a_{\pm} &= \sqrt[v]{(\gamma_+ m_+)^{v_+} (\gamma_- m_-)^{v_-}} \\ &= \sqrt[v]{(\gamma_+)^{v_+} (\gamma_-)^{v_-}} \sqrt[v]{(m_+)^{v_+} (m_-)^{v_-}} = \gamma_{\pm} m_{\pm}. \end{aligned} \quad (9.85)$$

The quantity γ_{\pm} thus defined is called the *mean activity coefficient*. Although this quantity is a state function, its determination is not an easy task. The molecular structure of melts and solutions of electrolytes is rather complicated and strongly depends on the composition. Thus, the calculation of the fundamental equation – as well as the mean activity coefficient – based on statistical thermodynamical methods is usually not feasible. The experimental determination of the mean activity coefficient can be done by the usual methods (e.g., osmotic pressure or vapor pressure measurements), or with the help of suitable galvanic cells discussed

in a subsequent section. However, it can be calculated for the case of considerably dilute ionic solutions, using pertinent approximations. The result of these calculations is called the *Debye–Hückel limiting law* – named after the first scientists to do the calculations.⁹ According to this law, the logarithm to base 10 of the mean activity coefficient of an ion in a sufficiently dilute electrolyte solution can be given as

$$\log_{10} \gamma_{\pm} = -A |z_+ z_-| \sqrt{\frac{I}{m^{\ominus}}}, \quad (9.86)$$

where I is the *ionic strength*, defined on a molality basis as

$$I = \frac{1}{2} \sum_{i=1}^J z_i^2 m_i, \quad (9.87)$$

and the factor A (also called as the *Debye–Hückel constant*) is

$$A = \frac{\ln 10 \cdot F^3}{4\pi N_A} \sqrt{\frac{\rho m^{\ominus}}{2\epsilon^3 R^3 T^3}}, \quad (9.88)$$

In this expression, $\ln 10$ relates the natural logarithm (to base e) to base 10, F is the Faraday constant, N_A the Avogadro constant, R the gas constant, T the temperature, ϵ the electric permittivity and ρ the density of the solution. The value of A for water as a solvent at $T = 298$ K and $\rho = 0.997$ kg dm⁻³, using $m^{\ominus} = 1$ mol kg⁻¹ and $\epsilon = 78.54 \epsilon_0$ is 0.509. Using this value, we can calculate the mean activity coefficient in highly dilute solutions.

It is important to know that (9.86)–(9.88) can only be applied if the validity of approximations used to derive the Debye–Hückel law holds; i.e., in ideally dilute solutions where the ions are completely solvated and the structure of the solvation shell does not change upon further dilution. In addition to supposing spherical electric field around the ions, the thermal energy of the ions kT is also supposed to be much smaller than the electrostatic interaction energy between the (distant) ions. These conditions are satisfactorily fulfilled at electrolyte concentrations below some 10⁻⁵ mol kg⁻¹, but the formula gives reasonable approximation up to 10⁻⁴–10⁻³ mol kg⁻¹. (There exist also “extended” versions of (9.86) which give better approximations at somewhat higher concentrations as well.) From this we can

⁹Peter Joseph Wilhelm Debye (1884–1966) was a Dutch physicist, working at German and Swiss universities, and finally at Cornell University in the United States. He received the Nobel-prize in chemistry in 1936, also for contributions to the knowledge of molecular structure through his investigations on dipole moments. He published the theory for dilute electrolyte solutions – later named after the two scientists – together with Hückel in 1923. Erich Armand Joseph Hückel (1896–1980) was a German physicist and mathematician. His most important work is the introduction of simplified quantum mechanical methods to describe molecular orbitals (later called the Hückel MO theory), which also led to the interpretation of the aromatic structure. He co-authored the Debye–Hückel theory while working with Debye in Zürich.

conclude that, while solutions containing uncharged particles can be considered as ideal solutions at high dilutions, in ionic solutions, the deviation from ideality outlast for quite high dilutions. This is the reason to call the formula in (9.86) as the Debye–Hückel *limiting* law. Note also that – within the range of validity of the limiting law – the ionic activity decreases with increasing ionic strength of the solution.

An important result of the limiting law is the description of the change of the activity coefficient as a function of the electrolyte concentration m_{\pm} . This enables to determine the standard chemical potential μ_{\pm}^{\ominus} by extrapolating experimental results to $m_{\pm} = 0$. For example, in a solution containing only one electrolyte dissociating into two ions of charge number $+1$ and -1 (a so-called *1:1 binary electrolyte*), the ionic strength calculated using (9.87) is:

$$I = \frac{1}{2} \sum_{i=1}^2 z_i^2 m_i = \frac{1}{2} (m_+ + m_-) = m_{\pm}. \quad (9.89)$$

Substituting this in (9.86), we get:

$$\log_{10} \gamma_{\pm} = -A |z_+ z_-| \sqrt{\frac{m_{\pm}}{m^{\ominus}}}. \quad (9.90)$$

According to this result, the logarithm of the mean activity coefficient goes to zero (i.e., γ_{\pm} goes to one, the value in an ideal solution) proportional to the square root of the molality as the concentration goes to zero. From this, we can conclude that γ_{\pm} cannot become unit for arbitrarily small but finite concentration, only at exactly zero concentration.

9.2.2 Chemical Potential of Ions in an Electric Field: The Electrochemical Potential

Let us write the Euler relation (2.33) for a system containing electric charge q in an electric field of strength φ , according to (9.3):

$$U = TS - PV + \sum_{i=1}^K \mu_i n_i + \varphi q. \quad (9.91)$$

Let us also take into consideration that electric charge can only be present in the form of *charge carriers*; thus, we can write the charge q as the sum of the charges “carried” by the J ionic species:

$$q = \sum_{j=1}^J z_j F n_j. \quad (9.92)$$

Obviously, the charge carried by the ionic species is proportional to their amount n_j ; thus, their electric contribution to the internal energy is also proportional to n_j – similarly to the contribution of the chemical potential μ_i of the species. The chemical potential determines the change in internal energy if the amount of a given species changes. However, in an electric field, the change of the amount of an ionic species necessarily involves the change of the carried charge as well. Thus, the change in the amount of an ionic species includes the change of energy due to the accompanying change of its charge, so we have to include the change of electric energy into the chemical potential. The change of the “pure chemical” energy and the electric energy are not and cannot be independent; therefore, it is practical to treat them as one quantity. This quantity is called the *electrochemical potential*:

$$\mu_j = \tilde{\mu}_j + z_j F\varphi. \quad (9.93)$$

This definition reflects that the charge belongs to the chemical “character” of the charge carrier. We get the same result by derivation of the U function given in (9.91) with respect to the amount of the component n_j – which is the very definition of the chemical potential. Consequently, the above quantity μ_j is the chemical potential in an electric field. However, to stress the fact that it includes a nonzero electric contribution, it is often called the electrochemical potential.

An important property of the electrochemical potential defined by (9.93) is that the “pure chemical” part $\tilde{\mu}_j$ (the value of the chemical potential in a zero-potential field) cannot be separated uniquely from the electric part $z_j F\varphi$, as the chemical potential of the individual ion is not uniquely determined either. (As it has been concluded in the previous section, even in case of zero potential we can only determine μ_j up to an arbitrary additive constant, and thus the potential $\tilde{\mu}_j$ as well.) However, if we want to stress the electric interaction separately, the Euler relation for the internal energy can then be written in the following form:

$$U = TS - PV + \sum_{i=1}^{K-J} \mu_i n_i + \sum_{j=1}^J (\tilde{\mu}_j + z_j F\varphi) n_j. \quad (9.94)$$

As a result of the above considerations, we can state that chemical equilibria of charge carriers can be treated similarly to any other species the way we treated them before; the condition of electrochemical equilibrium in case of charged species which can move freely between two phases is the equality of their electrochemical potentials within the two phases. For any (freely moving) ions, the equality

$$\mu_i^\alpha = \mu_i^\beta \quad (9.95)$$

should hold; even if the electric potential φ^α and φ^β of the phases α and β are not equal.¹⁰ Based on the formal decomposition of the electrochemical potential according to (9.93), we can write this condition in the following form:

$$\tilde{\mu}_i^\alpha + z_i F \varphi^\alpha = \tilde{\mu}_i^\beta + z_i F \varphi^\beta. \quad (9.96)$$

The equilibrium electric potential difference between the two phases can be given based on this equation:

$$\mu_i^\beta - \mu_i^\alpha = \tilde{\mu}_i^\beta - \tilde{\mu}_i^\alpha + z_i F (\varphi^\beta - \varphi^\alpha). \quad (9.97)$$

However, as the “pure chemical” part $\tilde{\mu}_j$ cannot be separated uniquely from the electric part $z_j F \varphi$, the difference $\tilde{\mu}_i^\beta - \tilde{\mu}_i^\alpha$ is not unique either; i.e., it is not a thermodynamically sound quantity. Accordingly, the electric potential difference $\varphi^\beta - \varphi^\alpha$ cannot be determined either. Fortunately, there is an exception; if the chemical composition of the two phases is identical, then the “purely chemical” terms $\tilde{\mu}_i^\beta$ and $\tilde{\mu}_i^\alpha$ are also identical, thus their difference is zero. Consequently, only the electric potential difference of phases of *identical chemical composition* can be defined according to the relation:

$$\mu_i^\beta - \mu_i^\alpha = z_i F (\varphi^\beta - \varphi^\alpha). \quad (9.98)$$

Based on this relation, we can obtain the condition of electric equilibrium between two phases from the general condition $\mu_i^\beta = \mu_i^\alpha$ for phases of identical composition:

$$\varphi^\beta = \varphi^\alpha. \quad (9.99)$$

It is in accordance with the general condition of equilibrium that the intensive variables characteristic to the given interaction are identical within the entire system.

9.2.3 Heterogeneous Electrochemical Equilibria: The Galvanic Cell

The most important electrochemical device in everyday life is the *galvanic cell*.¹¹ This device usually contains two ion-conducting phases and two

¹⁰We consider as the potential of the phase the *inner potential*, which can be measured inside the phase, in contrast with the *outer potential*, which can be measured on the surface of the phase at an infinitely small distance.

¹¹The name is derived from the family name of the Bolognese medical doctor, Luigi Galvani (1737–1798). He was the first to describe the device nowadays called an electrochemical cell, which he discovered while dissecting frogs, and first interpreted its electric power as the product of living cells. The galvanic cell is the version where – if joining the terminal wires – a spontaneous

Fig. 9.4 Possible arrangement of a silver-zinc galvanic cell with copper terminals

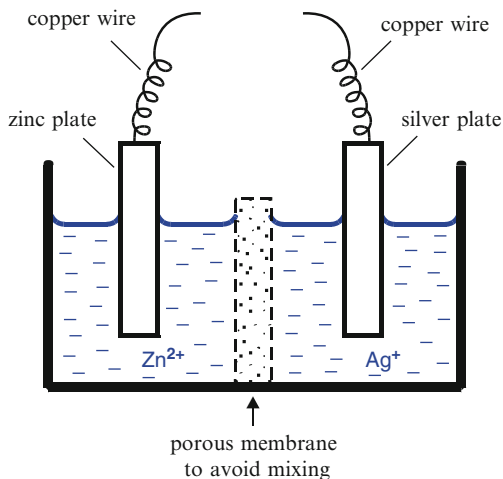

electron-conducting phases arranged in a way that each electron-conducting phase is in contact with an ion-conducting phase, and the two ion-conducting phases are in contact with each other. It is common practice to include also the terminal wires (of the same metal) attached to the electron-conducting phases.

We shall demonstrate the thermodynamic description on the example of a galvanic cell consisting of zinc metal immersed into an aqueous solution containing zinc ions, and of silver metal immersed into an aqueous solution containing silver ions, along with a couple of copper terminal wires. A possible physical arrangement of the cell is shown in Fig. 9.4.

The cell can be described symbolically by the *cell diagram*, which contains the following elements from left to right, in a fixed order: left terminal metal, left electron-conducting phase, left ion-conducting phase, right ion-conducting phase, right electron-conducting phase, and right terminal metal. (Some special cells may contain more elements than these. In that case, additional elements are written in the appropriate places.) The diagram of the example cell can be written the following way:

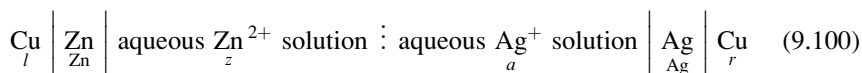

Solid vertical bars symbolize solid | solid or solid | liquid phase boundaries, while dotted bars a miscible liquid \vdots liquid phase boundary. To identify actual phases, we use the short symbols written below the diagram.

electric current is flowing. The other version is called an *electrolytic cell*, in which an external voltage drives a current of opposite direction to that of the galvanic cell.

Let us write the condition of electrochemical equilibria for phases in contact with each other. Between the metals, it is the electron that can freely pass:

$$\mu_{e^-}^l = \mu_{e^-}^{Zn}, \quad (9.101)$$

$$\mu_{e^-}^r = \mu_{e^-}^{Ag}. \quad (9.102)$$

Between metals and metallic ion solutions, it is the metal ion that can freely pass (i.e., get solved from the metal or precipitated onto it):

$$\mu_{Zn^{2+}}^{Zn} = \mu_{Zn^{2+}}^z, \quad (9.103)$$

$$\mu_{Ag^+}^a = \mu_{Ag^+}^{Ag}. \quad (9.104)$$

The electric potential difference between the right and the left terminals is well determined, as they are chemically identical. The nonzero potential difference is the result of a constrained equilibrium; phases are in contact only pairwise, preventing an unconstrained overall chemical and electric equilibrium. Substituting the charge number of electron $z_{e^-} = -1$ into (9.98), we get:

$$-F(\varphi^r - \varphi^l) = \mu_{e^-}^r - \mu_{e^-}^l. \quad (9.105)$$

Using the previous equations for equilibrium condition, we can rewrite it as:

$$-F(\varphi^r - \varphi^l) = \mu_{e^-}^{Ag} - \mu_{e^-}^{Zn}. \quad (9.106)$$

Let us make use of the possibility that the chemical potential of metals – similarly to that of electrolytes – can be written as the sum of the metal ion and electron. Writing this identity for one electron, we get:

$$\frac{1}{2} \mu_{Zn}^{Zn} = \frac{1}{2} \mu_{Zn^{2+}}^{Zn} + \mu_{e^-}^{Zn}, \quad (9.107)$$

$$\mu_{Ag}^{Ag} = \mu_{Ag^+}^{Ag} + \mu_{e^-}^{Ag}. \quad (9.108)$$

With the help of the above equations, we can express the chemical potential difference $\mu_{e^-}^{Ag} - \mu_{e^-}^{Zn}$ in terms of the chemical potentials of the metal ions instead of the electron:

$$-F(\varphi^r - \varphi^l) = \mu_{Ag}^{Ag} - \mu_{Ag^+}^{Ag} - \frac{1}{2} \mu_{Zn}^{Zn} + \frac{1}{2} \mu_{Zn^{2+}}^{Zn}. \quad (9.109)$$

Making use of the equalities (9.103) and (9.110), after some rearrangement, we can write this in the following form:

$$-F(\varphi^r - \varphi^l) = \mu_{\text{Ag}}^{\text{Ag}} + \frac{1}{2}\mu_{\text{Zn}^{2+}}^z - \frac{1}{2}\mu_{\text{Zn}}^{\text{Zn}} - \mu_{\text{Ag}^+}^a. \quad (9.110)$$

The difference on the right-hand side

$$\left(\mu_{\text{Ag}}^{\text{Ag}} + \frac{1}{2}\mu_{\text{Zn}^{2+}}^z\right) - \left(\frac{1}{2}\mu_{\text{Zn}}^{\text{Zn}} + \mu_{\text{Ag}^+}^a\right)$$

can be interpreted – in analogy of (8.15) – as the Gibbs potential $\Delta_r G$ of the reaction

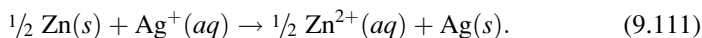

Based on these results, we can conclude that the equilibrium potential difference of a galvanic cell is independent of the terminal metal; it depends only of the cell reaction (i.e., the setup of the cell). This is the reason we can call the difference as the *potential of the cell reaction*. To formulate the general thermodynamic expression of this potential, we have to consider another important property of contact equilibria. In the example, we have written the conditions of equilibrium for one single electron. Of course, we could write the same equations for an arbitrary number of electrons – in the example, two electrons are also a natural choice. It is obvious that the electric potential difference of the cell cannot depend on this choice. To show this, we can consider the results obtained by writing the appropriate equations for two electrons instead of one. We should write the double of the chemical potentials and $z = -2$ instead of $z_e = -1$:

$$-2F(\varphi^r - \varphi^l) = 2\mu_{\text{Ag}}^{\text{Ag}} + \mu_{\text{Zn}^{2+}}^z - \mu_{\text{Zn}}^{\text{Zn}} - 2\mu_{\text{Ag}^+}^a. \quad (9.112)$$

The cell reaction should be also written accordingly as:

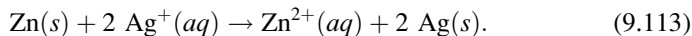

Comparing the two stoichiometric equations we can see that, when writing the equation for one electron, a single elementary charge is exchanged between $\frac{1}{2} \text{Zn}$ and Ag^+ , while in case of two electrons, the number of elementary charges exchanged is 2. The number of elementary charges exchanged in a reaction is called the *charge number of the cell reaction*; it is an integer number denoted by n . Thus, the potential of the cell reaction E can be written as:

$$-nFE = \Delta_r G. \quad (9.114)$$

As the Gibbs potential of the reaction $\Delta_r G$ is proportional to the charge number n , it is immaterial how we write the cell reaction – which supports the reliability of the equations for contact equilibria. It can also be seen from the equation that the

correct sign of the cell potential can only be obtained if we write the stoichiometric equation in the proper direction. In the example discussed, this is the direction according to which Zn is oxidized at the left-hand side metal-solution boundary (and gets dissolved in the solution), while Ag^+ ions are reduced at the right-hand side metal-solution boundary (and precipitated onto the metal surface). As the cell potential, E is always calculated by subtracting the potential of the left terminal from that of the right terminal, the cell reaction should always be written in a way that oxidation should occur on the surface of the left electron conducting phase and reduction on the surface of the right electron conducting phase. The sign of the cell potential at the actual concentrations is determined by the sign of the reaction Gibbs potential $\Delta_r G$. If its sign is negative (i.e., the reaction spontaneously proceeds from left to right at constant temperature and pressure), then E is positive, and vice versa. It follows from the above arguments that, if the cell diagram is reversed, the stoichiometric equation should also be reversed. Consequently, the stoichiometric equation determines the arrangement of the cell diagram.

Having in mind the thermodynamics of chemical reactions discussed in Chap. 8, it seems to be worth to relate the reaction Gibbs potential to the standard reaction Gibbs potential, thus connecting the potential of the cell reaction to the equilibrium constant. Let us start by expressing the chemical potentials in (9.112) as a function of composition. The composition of pure metals does not change, that of the ions in the solution can be given as a function of their activity:

$$\mu_{\text{Ag}^+}^a = \mu_{\text{Ag}^+}^{\ominus a} + RT \ln a_{\text{Ag}^+}^a, \quad (9.115)$$

$$\mu_{\text{Zn}^{2+}}^z = \mu_{\text{Zn}^{2+}}^{\ominus z} + RT \ln a_{\text{Zn}^{2+}}^z. \quad (9.116)$$

Upon substitution into (9.112) and rearrangement, we get:

$$\begin{aligned} -2F(\varphi^r - \varphi^l) &= 2\mu_{\text{Ag}}^{\text{Ag}} - 2\mu_{\text{Ag}^+}^{\ominus a} - 2RT \ln a_{\text{Ag}^+}^a \\ &\quad - (\mu_{\text{Zn}}^{\text{Zn}} - \mu_{\text{Zn}^{2+}}^{\ominus z} - RT \ln a_{\text{Zn}^{2+}}^z). \end{aligned} \quad (9.117)$$

Let us express from this equation the potential difference $E = \varphi^r - \varphi^l$:

$$2E = \left(2 \frac{\mu_{\text{Ag}^+}^{\ominus a} - \mu_{\text{Ag}}^{\text{Ag}}}{F} + \frac{2RT}{F} \ln a_{\text{Ag}^+}^a \right) - \left(\frac{\mu_{\text{Zn}^{2+}}^{\ominus z} - \mu_{\text{Zn}}^{\text{Zn}}}{F} + \frac{RT}{F} \ln a_{\text{Zn}^{2+}}^z \right). \quad (9.118)$$

The first and third terms do not depend on the composition and contain standard chemical potentials, thus their difference can be considered as the standard (electric) potential. Let us denote this difference by $2E^\ominus$; from which we obtain the standard potential as

$$E^\ominus = 2 \frac{\mu_{\text{Ag}^+}^{\ominus a} - \mu_{\text{Ag}}^{\text{Ag}}}{F} - \frac{\mu_{\text{Zn}^{2+}}^{\ominus z} - \mu_{\text{Zn}}^{\text{Zn}}}{F}. \quad (9.119)$$

Using this notation and combining the two other (logarithmic) terms in a fraction, we obtain the following relation:

$$E = E^\ominus + \frac{RT}{2F} \ln \frac{\left(a_{\text{Ag}^+}^a\right)^2}{a_{\text{Zn}^{2+}}^z}. \quad (9.120)$$

This is called the *Nernst equation* (for the given cell).

The standard potential E^\ominus can also be obtained in a different way. Based on (9.114), we can write

$$-nFE^\ominus = \Delta_r G^\ominus. \quad (9.121)$$

From (8.19), the standard reaction Gibbs potential $\Delta_r G^\ominus$ can be written in the form $-RT \ln K_a$, where K_a is the equilibrium constant of the reaction. Combining these, we can express the standard potential from the thermodynamic data of the cell reaction in the following form:

$$E^\ominus = -\frac{\Delta_r G^\ominus}{nF} = \frac{RT}{nF} \ln K_a. \quad (9.122)$$

We can arrive to this result also by considering that the state according to a purely chemical equilibrium occurs in the cell if there is no potential difference between the two terminal metals, that is, $E = 0$. In this case, the argument of the logarithmic term of (9.120) contains the equilibrium activities, thus it gives the equilibrium constant. Upon substitution and rearrangement, we get the above result.

We can summarize the above results by extending it to a general case. If in a cell that is characterized by the cell diagram

$$\begin{array}{c|c|c|c|c|c} \text{left} & \text{left electron} & \text{left} & \vdots & \text{right} & \text{right electron} & \text{right} \\ \text{terminal} & \text{conductor} & \text{ion conductor} & \vdots & \text{ion conductor} & \text{conductor} & \text{terminal} \end{array} \quad (9.123)$$

the general *charge transfer reaction*

$$\sum_{i=1}^R v_i A_i = 0 \quad (9.124)$$

occurs, whose charge number is n , then the equilibrium electric potential difference between the right and the left terminal – the potential of the cell reaction – is given by the Nernst equation:

$$E = E^\ominus + \frac{RT}{nF} \ln \prod_{i=1}^J (a_i)^{v_i}. \quad (9.125)$$

The product contains the activities of the J components of the reaction present in the solution, raised to the power of their stoichiometric numbers. (Pure solid phases are not included.) The standard potential E^\ominus can be calculated from the standard reaction Gibbs potential $\Delta_r G^\ominus$ according to (9.122):

$$E^\ominus = -\frac{\Delta_r G^\ominus}{nF}$$

9.2.4 Electrodes and Electrode Potentials

The discussion of the above example of a galvanic cell led us to the expression (9.118) of the electric potential difference containing two terms. One term depends only on the properties of the left electrolyte solution and the electron conductor submerged into this solution, the other term depends only on those of the right electrolyte solution and the right electron conductor. This is also true for any galvanic cell; they can be divided into a *left half cell* and a *right half cell*, whose contributions to the electric potential difference can be treated separately. These half cells are also called *electrodes*.¹²

Accordingly, the cell diagram (9.100) can be decomposed into two electrodes:

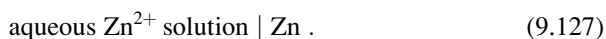
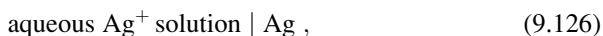

Writing the diagram of half cells, we drop the terminal metal as it has no importance if it is alone at one side only, and the ionic conductor is always on the left side – the reason for this will be explained soon. Equation (9.118) already suggested that we can express the *electrode potential*, and thus the *electrode reaction* as well, for individual electrodes. To obey the principle of the conservation of charge, the electrode reaction should also contain the electron. The two electrode reactions in the example can be written as follows:

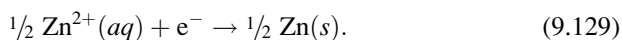

¹²The names *anode*, *cathode*, and *electrode* have been introduced by Faraday who discovered the migration of ions. The actual forms of these names were proposed to Faraday by the scientist and priest William Whewell (1794–1866). The Greek word *ανωδος* refers to the rising sun, while *καθωδος* to the setting sun, thus expressing the opposite direction of the current at the two terminals with respect to the cell. The (positive) current enters the cell on the anode and leaves the cell on the cathode. The word *electrode* is a generalized expression referring to a current passing through a half cell.

We can obtain the cell reaction (9.113) by subtracting the twofold of the zinc electrode reaction from the twofold of the silver electrode reaction (i.e., we add the twofold opposite reaction of the zinc electrode). The factor two arises as a consequence of writing electrode reactions always for one electron transfer, while (9.118) refers to two electrons. Accordingly, the potential of the silver electrode is half of the first term of (9.118):

$$\varepsilon_{\text{Ag}^+/\text{Ag}} = \frac{\mu_{\text{Ag}^+}^{\ominus a} - \mu_{\text{Ag}}^{\text{Ag}}}{F} + \frac{RT}{F} \ln a_{\text{Ag}^+}^a, \quad (9.130)$$

and that of the zinc electrode is half of the second term of the equation:

$$\varepsilon_{\text{Zn}^{2+}/\text{Zn}} = \frac{\mu_{\text{Zn}^{2+}}^{\ominus z} - \mu_{\text{Zn}}^{\text{Zn}}}{2F} + \frac{RT}{2F} \ln a_{\text{Zn}^{2+}}^z. \quad (9.131)$$

The potential difference of the cell can be calculated from these results the same way as the stoichiometric equation of the cell reaction from the electrode reactions; we should subtract the twofold of the potential of the Zn^+/Zn electrode from the twofold of the potential of the Ag^+/Ag electrode.

It is easy to see why we write the diagram of the electrodes as a “right-hand side half cell”; the equilibrium electric potential of the entire cell is obtained by subtracting the left-hand side half cell from the right-hand side half cell. To calculate the potential difference of the cell, the cell reaction should have been written in a way that reduction should occur on the right electrode and oxidation on the left electrode. If electrode reactions are always written as reductions, the potential to be subtracted will always mean the opposite reaction, that is, oxidation.

Similarly to the potential of the cell reaction, we can also divide the potential of the electrode reaction into a *standard electrode potential* and a second term containing a composition-dependent quantity:

$$\varepsilon_{\text{Ag}^+/\text{Ag}} = \varepsilon_{\text{Ag}^+/\text{Ag}}^{\ominus} + \frac{RT}{F} \ln a_{\text{Ag}^+}, \quad (9.132)$$

$$\varepsilon_{\text{Zn}^{2+}/\text{Zn}} = \varepsilon_{\text{Zn}^{2+}/\text{Zn}}^{\ominus} + \frac{RT}{2F} \ln a_{\text{Zn}^{2+}}. \quad (9.133)$$

As it can be seen from these expressions, the standard potential of the electrodes corresponds to the solution of unit activity. We could say that it can be *measured* if the solution is of unit activity; however, this raises a problem that has emerged already when dividing the cell into electrodes (half cells). While (9.118) and (9.120) describing the potential difference of the cell contain only well-determined thermodynamic quantities (differences of chemical potentials and ratios of activities), (9.132) and (9.133) describing electrode potentials contain the chemical potential and the activity of individual ions, which are not well determined. Consequently, these latter do not have a unique physical significance. There are

two possibilities to overcome this ambiguity. We could either fix the undetermined additive constant in the chemical potential of the ions (which is equivalent to fixing the undetermined multiplicative constant in their activity), or fix the additive constant in the electrode potentials derived from the chemical potentials. In the praxis, this latter has been implemented; the standard electrode potential of the *hydrogen electrode* has been fixed to zero.

According to this convention, to calculate the potential difference of a cell whose left electrode is a standard hydrogen electrode, we should subtract from the potential of the right electrode exactly zero volts. In other words, the cell potential of this galvanic cell is exactly the electrode potential of the right electrode. The *standard hydrogen electrode* is given by the following diagram:

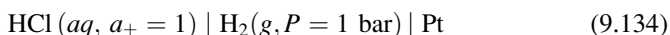

Here, $\text{HCl}(aq, a_{\pm} = 1)$ designates the aqueous solution of HCl where the activity of the H^+ ion is unit, and $\text{H}_2(g, P = 1 \text{ bar})$ specifies that this HCl solution is saturated by hydrogen gas of 1 bar pressure.¹³ By definition, this half cell has an electrode potential of exactly 0 V.

By expressing the potential of the hydrogen electrode from the equilibrium conditions, we get the result

$$\epsilon_{\text{H}^+/\frac{1}{2}\text{H}_2} = \frac{\mu_{\text{H}^+}^{\ominus} - 1/2 \mu_{\text{H}_2}}{F} + \frac{RT}{F} \ln a_{\text{H}^+}, \quad (9.135)$$

from which we can conclude that the standard potential $\epsilon_{\text{H}^+/\frac{1}{2}\text{H}_2}^{\ominus}$ is only zero if the standard chemical potential of the aqueous H^+ ion is zero. (The chemical potential of the pure hydrogen gas – being a stable element – is zero by definition.) In other words, fixing the electrode potential of the standard hydrogen electrode at zero is equivalent to fixing the standard chemical potential of the aqueous H^+ ion at zero.

The electrode reaction in the hydrogen electrode can be written as:

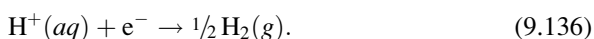

The peculiarity of this reaction is that its product is a gas, not a solid. However, as we can see from the “electrode diagram”, the electron conductor is platinum metal, which dissolves a considerable amount of hydrogen. As a consequence, the oxidation of the hydrogen gas or the reduction of the H^+ ions occurs on the surface of platinum. Electrodes of similar constitution (i.e., containing a dissolved reactive gas in an electron conductor) are called *gas electrodes*.

Although we can calculate the cell potential after having fixed the standard potential of the hydrogen electrode to zero, this potential is not necessarily the one we could measure in a cell in electrochemical equilibrium. An *equilibrium cell* is the one in which there is no net current flowing, and there is equilibrium at each phase

¹³Prior to the introduction of the SI, the reference pressure was 1 atm = 1.01325 bar. As a consequence, electrode potentials found in tables referenced to a hydrogen pressure of 1.01325 bar are higher than the currently used values referenced to 1 bar by 0.169 mV (0.000169 V).

boundary – except for the liquid–liquid phase boundary. At this boundary, charge carriers should pass freely from one phase to the other, but the (miscible) liquids are not allowed to mix. (Equilibrium at this boundary could have been achieved by complete mixing, but the porous membrane separating the liquids does not allow for mixing. In case of the example cell, this mixing would lead to the precipitation of silver onto the surface of the zinc metal. The membrane acts to avoid this process.) Charge carriers passing across the membrane will give rise to a liquid-liquid junction potential (usually called liquid junction potential or simply junction potential), which adds to the potential difference of the electrodes. The origin of the liquid junction potential is that the eventual different concentration and the different diffusion velocity across the boundary leads to different spatial distribution of ions, which gives rise to a potential across the boundary. (This is the reason to call it as *diffusion potential*.) Thus, it is not an equilibrium property but is a result of ionic migration.

An equilibrium description of the liquid junction potential can be illustrated in the example of the zinc–silver cell discussed above. Let us start from (9.110) writing E in place of the potential difference $\varphi^r - \varphi^l$:

$$-FE = \mu_{\text{Ag}}^{\text{Ag}} - \mu_{\text{Ag}^+}^a - \frac{1}{2} \mu_{\text{Zn}}^{\text{Zn}} + \frac{1}{2} \mu_{\text{Zn}^{2+}}^z \quad (9.137)$$

Let us write the chemical potentials for the case when AgNO_3 is the source of Ag^+ ions and $\text{Zn}(\text{NO}_3)_2$ is the source of Zn^{2+} ions. Using the relation between the chemical potential of the electrolytes and the constituting ions, we can write:

$$\mu_{\text{Ag}^+}^a = \mu_{\text{AgNO}_3}^a - \mu_{\text{NO}_3^-}^a, \quad (9.138)$$

$$1/2 \mu_{\text{Zn}^{2+}}^z = 1/2 \mu_{\text{Zn}(\text{NO}_3)_2}^z - \mu_{\text{NO}_3^-}^z. \quad (9.139)$$

Upon substitution into the equation describing the cell potential, we get:

$$-FE = \mu_{\text{Ag}}^{\text{Ag}} - \mu_{\text{AgNO}_3}^a + \mu_{\text{NO}_3^-}^a - 1/2 \mu_{\text{Zn}}^{\text{Zn}} + 1/2 \mu_{\text{Zn}(\text{NO}_3)_2}^z - \mu_{\text{NO}_3^-}^z \quad (9.140)$$

Let us expand this equation by terms that cancel¹⁴ and rewrite it by regrouping terms:

$$\begin{aligned} -FE &= \left(1/2 \mu_{\text{Zn}}^{\text{Zn}} - 1/2 \mu_{\text{Zn}(\text{NO}_3)_2}^z + RT \ln m_{\text{NO}_3^-}^z \right), \\ &+ \left(\mu_{\text{NO}_3^-}^z - \mu_{\text{NO}_3^-}^a + RT \ln \frac{m_{\text{NO}_3^-}^a}{m_{\text{NO}_3^-}^z} \right), \\ &- \left(\mu_{\text{Ag}}^{\text{Ag}} - \mu_{\text{AgNO}_3}^a + RT \ln m_{\text{NO}_3^-}^a \right). \end{aligned} \quad (9.141)$$

¹⁴To expand, let us add the term $RT \left(\ln m_{\text{NO}_3^-}^z - \ln m_{\text{NO}_3^-}^a + \ln \frac{m_{\text{NO}_3^-}^a}{m_{\text{NO}_3^-}^z} \right) = 0$.

Considering this result we can state that the first term on the right-hand side (in the first line) is only related to the zinc electrode (including its electrolyte solution), and the third term (in the third line) is only related to the silver electrode (including its electrolyte solution). The second term is only related to the two electrolyte solutions. Consequently, we could say that the first term is the potential of the zinc electrode, the third term is that of the silver electrode, while the middle term is the liquid junction potential. However, we should keep in mind that several other ions can also take part in the charge transfer in addition to the NO_3^- ion, thus writing and regrouping terms in the above equation is arbitrary. At the same time, we can also conclude that, if the concentration of the solutions a and z are identical, there is no potential difference at the boundary of the solutions. This can be approximated for example, by adding a large amount of KNO_3 into both solutions in addition to AgNO_3 and $\text{Zn}(\text{NO}_3)_2$ so that the composition of the two solutions is only slightly different. In this case, the liquid junction potential can be neglected compared to the cell potential. If necessary, we can calculate the diffusion potential by writing equations for the nonequilibrium transport of the ions.

If the nature of the cell enables to use a common solvent as ion conductor for both electrodes, it completely eliminates the liquid junction potential. Another method is the *salt bridge* that efficiently eliminates the junction potential. In the salt bridge, there is a high concentration electrolyte solution containing ions of nearly identical diffusion velocity (e.g., KCl or NH_4NO_3), which also diminishes the junction potential to a level that can be neglected. In the cell diagram of cells with negligible junction potential, the liquid-liquid phase boundary is symbolized by a double dotted bar ($::$) instead of the usual single dotted bar ($:$). For reasons not discussed here, these are called as *cells without transference*.

Problems

1. At 18°C , water rises at a height of 5 cm in a glass capillary of 0.3 mm radius. The density of water at this temperature is 998.6 kg m^{-3} . Based on the given data, calculate the equilibrium vapor pressure of water above a water drop with a radius of 10 nm. The vapor pressure over a plane water surface is 2.1 kPa. Suppose that the surface of water in the capillary is spherical with a zero contact angle at the glass wall.

Solution: First we shall determine the surface tension of water from (9.29):

$$\gamma = \frac{\rho g r h}{2} = 73.55 \text{ N m}^{-1}.$$

The vapor pressure above the water droplet can be determined using the Kelvin equation (9.43)

$$P_r = P_0 e^{\frac{2\gamma M}{RT r \rho}} = 2.343 \text{ kPa}.$$

Thus, the vapor pressure of a 10 nm radius water droplet is 11.6 % higher than the equilibrium pressure over a flat water surface.

2. An assumption of the Debye–Hückel theory is that the concentration distribution as a function of distance of the charged particles i around a chosen central ion is given as the first-power term of a power series of the function

$$c_i(r) = \bar{c}_i \exp\left[-\frac{ez_i\varphi(r)}{kT}\right].$$

Here, \bar{c}_i is the average concentration of the charged particles i in the solution, e is the elementary charge, z_i is the charge number of the particles, $\varphi(r)$ is the electric potential at a distance r from the central ion, and k is the Boltzmann constant. To get the radial charge density around the central ion, the above function is summed for all charged particles in the solution.

Based on these considerations, argue why the theory works better for a solution of pure KCl than for that of pure CaBr_2 .

Solution: Let us write the charge density $\rho(r)$ around the central ion as a power series expansion up to the second-order term in $\varphi(r)$ summing for all the ionic species, multiplied by the respective ionic charge $z_i F$:

$$\rho(r) = \sum_i \bar{c}_i z_i F - \sum_i \frac{\bar{c}_i F^2 z_i^2}{RT} \varphi(r) + \sum_i \frac{\bar{c}_i F^3 z_i^3}{R^2 T^2} \varphi^2(r).$$

The first term of the above expression is the charge density at the position of the central ion (at $r = 0$). This is always zero, regardless of the nature of the electrolyte – based on the electroneutrality principle as expressed in (9.48). The second term is identical to the approximation used by Debye and Hückel. By inspecting the third term, we can state that for 1:1 electrolytes (and every higher term containing even powers of φ) it is also zero as odd powers of the charge number z_i sum to zero. This does not apply for electrolytes such as CaBr_2 , where the absolute values of the charge numbers are not identical for the two ions. Thus, the truncation of the power series is a worse approximation than for 1:1 electrolytes.

Further Reading

- Bard AJ, Inzelt GY, Scholz F (eds) (2008) *Electrochemical dictionary*. Springer, Heidelberg
- Denbigh KG (1981) *The principles of chemical equilibrium*, 4th edn. Cambridge University Press, Cambridge
- Guggenheim EA (1985) *Thermodynamics: an advanced treatment for chemists and physicists*, 7th edn. North Holland, Amsterdam
- IUPAC Task Group (1994) *Standard quantities in chemical thermodynamics. Fugacities, activities and equilibrium constants for pure and mixed phases (IUPAC Recommendations 1994)*. *Pure Appl Chem* 66:533–552
- Mohr PJ, Taylor BN, Newell DB (2007) *CODATA recommended values of the fundamental physical constants: 2006*. National Institute of Standards and technology, Gaithersburg, MD
- Silbey LJ, Alberty RA, Moungi GB (2004) *Physical chemistry*, 4th edn. Wiley, New York

Chapter 10

Elements of Equilibrium Statistical Thermodynamics

During the development of phenomenological thermodynamics, several scientists tried to interpret its formalism on the basis of the movement of the multitude of molecules contained in the system. The first success of this effort was the derivation of equations of state of gases, which has inspired the name *kinetic theory of gases* for these calculations. Despite this success, the theory contained several contradictions, which could not be solved. (An important shortcoming was the fact that the description based on classical mechanics was symmetrical to the inversion of time, while real thermodynamic phenomena are irreversible with respect to time.) The breakthrough was made by Maxwell and Boltzmann who made use of the *probability distribution* of the energy of molecules. This invention led Boltzmann to the molecular interpretation of the second law of thermodynamics, thus explaining also the nature of entropy. In the last few years of the nineteenth century, Gibbs generalized and systematized the theory founded by Maxwell and Boltzmann to interpret thermodynamics on a statistical basis, and he also coined the expression *statistical mechanics*. In the first two decades of the twentieth century, the development of quantum mechanics enabled the understanding of the underlying physical basis of the formalism of statistical mechanics.

As it is stated in this book prior to the discussion of the postulates of thermodynamics, the number of particles in a macroscopic quantity of material is of the order of magnitude of the Avogadro constant (6.022×10^{23} particles/mol), thus it is hopeless to describe the behavior of individual particles; we must be satisfied with the description of the mean behavior of their assembly. Having realized this, it is immediately obvious that we should describe the large ensemble of molecules by the methods of probability theory. When comparing quantities calculated using probability theory with macroscopic observations, some mean properties of the assembly of particles – that is, *expected values* – can be identified with thermodynamic quantities. There are a surprisingly low number of such properties; thus, this description of the system leads to results readily applicable in thermodynamics. The foundation of thermodynamics based on this approach is called *statistical thermodynamics*, or, in a more general sense, *statistical physics*. Using this approach, equilibrium thermodynamics can be constructed in a simpler way, using fewer

postulates than in the phenomenological theory. However, we shall not follow the way of complete deduction of thermodynamics from the principles of statistical physics, as we have already introduced thermodynamics in a phenomenological postulatory manner. Instead, we suppose prior knowledge of thermodynamic principles and quantities and deal only with actual *calculations* of thermodynamic properties. As we shall see, this approach can lead to the calculation of the fundamental equations in a multitude of systems based on molecular properties of the constituent particles.

From the basic quantities used in thermodynamics, most of them – for example, the (internal) energy U , the composition n_i , the pressure P , the volume V – were already known from mechanics and chemistry, except for the entropy S and the temperature T . However, temperature was a quantity that could be measured even prior to thermodynamic theory; contrary to the entropy, which is derived from other measurable quantities using thermodynamic formalism. Therefore, one of the main thrusts of statistical thermodynamics is to determine entropy based on the mechanical behavior of the multitude of particles. Once the entropy of a system is determined as a function of U , V and the composition data n_i , it is a fundamental equation,¹ which enables to calculate any thermodynamic properties in any states (cf. Sect. 4.4.3).

10.1 The Microcanonical Ensemble

The foundations of phenomenological thermodynamics were developed first for simple, isolated systems. For similar reasons, we begin the treatment of statistical thermodynamics for the same systems, adding a further simplification of restricting the treatment to a *single component*. The *mechanical model* of a simple, isolated single-component system is a population of N identical molecules placed in a fixed volume V , having a fixed overall energy E . Following Gibbs, we call this model a *microcanonical ensemble*,² though it is also called as an N, V, E ensemble. Note that the composition variable is not the usual amount of substance n but the number of molecules N ; as we describe molecular properties. The relation between the two variables is provided by the Avogadro constant N_A .

The microcanonical ensemble can be interpreted in two ways. It can be thought of as a real ensemble consisting of a very large number of isolated systems in *different states* in accordance with the fixed values of N , V , and E . As these states are not discernable macroscopically, they are called *microstates*. It can also be thought of as a temporal succession of microstates in the same isolated system, where the microstate of the system changes in time but conserves the same values of

¹This is of course only true if we deal with *simple systems*, where the system cannot change energy with the surroundings but by means of volume work and heat. For more complicated systems, we have to include other extensive variables characterizing additional interactions.

²The origin of the name is related to the *canonical ensemble*. (See according footnote.)

N , V , and E . According to the *ergodic hypothesis*,³ the expected values of thermodynamic interest of a random variable over time and that over the ensemble are the same. Consequently, from a statistical point of view, the only relevant information is the probability of individual microstates of the ensemble, which is given by the probability distribution function over the microstates.

It is important to specify what does the notion “state” means from a statistical point of view. A state – as it refers to a large assembly of molecules – is to be understood in a quantum mechanical sense, that is, those states are considered to be different, which differ at least in one quantum number. However, quantum states of a *macroscopic* system are quite different from what we have learnt for individual isolated molecules. The number of different states for the multitude of molecules having complicated interactions is in the order of the magnitude of the Avogadro constant. As the energy of the system is finite, the energy of “neighboring” microstates is only slightly different. As a consequence, the system can have rather easy transitions between such states. (This can happen, for example, in case of collisions of the particles when they can exchange some energy – while the overall energy of the system remains unchanged.) According to quantum mechanics, such “easy” transitions can also happen by random fluctuations. From the point of view of the distribution of states, it means that each state has an equal probability. This principle is expressed by the *only postulate* of (equilibrium) statistical thermodynamics:

In a microcanonical ensemble, every permissible quantum state conform to the conditions of fixed N , E and V occurs with equal probability if the ensemble represents the equilibrium state of the system.

Let us discuss the consequences of this postulate. A particle system with a macroscopic constraint in a given quantum state quickly undergoes transitions exploring many microstates. As the probability of these microstates is equal, the system explores *all states* within finite time, thus attaining equilibrium. Removing the constraint (e.g., removing an internal wall) opens up the possibility of previously precluded microstates. As the system experiences again that the entirety of the states (now including new states) is equally probable, it will explore the newly available microstates as well within a finite time while attaining the new equilibrium. This means that the system explores the *maximum* of the permitted states available in equilibrium. This maximum principle reminds us of Postulate 2 of thermodynamics – what we shall consider more thoroughly later.

Another interesting point is the behavior of the system starting from a particular microstate, after a few transitions, if we suddenly reverse the time axis. In a mechanical system, movements are symmetrical with respect to the inversion of time, thus the system should go back to the starting microstate after exactly the same number of transitions as it took to reach the state of inversion. Now, the postulate formulated above makes this return impossible; the transition being *equally probable to any state* makes the system to explore them in a random way,

³The word ergodic has been coined by Boltzmann from the Greek words $\epsilon\rho\gamma\omega\nu$ = work and $\omicron\delta\omicron\varsigma$ = path.



Fig. 10.1 A microcanonical ensemble divided into two parts, which corresponds to an isolated system divided into two subsystems

thus necessarily losing the way back to where it came from. Consequently, the postulate assures the irreversibility of thermodynamic processes.

Let us discuss the consequences of the maximum principle mentioned above. Consider a thermodynamic system modeled by an E, V, N ensemble virtually divided into two parts, using the notation of Fig. 10.1.

As the variables of the entropy function $S(E, V, N)$ are extensive, the following equations hold:

$$\begin{aligned} N &= N_1 + N_2, \\ V &= V_1 + V_2, \\ E &= E_1 + E_2. \end{aligned} \tag{10.1}$$

Entropy is an extensive quantity, thus we can write the additivity relation:

$$S(E, V, N) = S_1(E_1, V_1, N_1) + S_2(E_2, V_2, N_2). \tag{10.2}$$

It is easy to recognize that the number of states in the entire system is the *product* of the number of states in the two subsystems. (As to each individual state in one of the subsystems, we can have any one of the other subsystem.) Denoting the number of states by the capital Greek letter Ω , we can write this property as:

$$\Omega(E, V, N) = \Omega_1(E_1, V_1, N_1) \Omega_2(E_2, V_2, N_2). \tag{10.3}$$

Taking the logarithm of both sides, the equation still holds:

$$\ln \Omega(E, V, N) = \ln \Omega_1(E_1, V_1, N_1) + \ln \Omega_2(E_2, V_2, N_2). \tag{10.4}$$

Comparing this with the additivity relation of entropy, we can conclude that the function $S(E, V, N)$ differs only by a constant factor from the function $\Omega(E, V, N)$:

$$S(E, V, N) = k \ln \Omega(E, V, N). \tag{10.5}$$

This is the expression of *entropy as a function of the number of states* in a microcanonical ensemble. The function $\Omega(E, V, N)$ is called the *microcanonical partition function*. Thus, we can state that we have reached the goal of statistical considerations; by determining the possible number Ω of microstates as a function of E, V and N and multiplying its logarithm by k , we get the entropy-based

fundamental equation.⁴ The partition function also specifies the probability distribution function over the microstates. All the Ω states are equally probable, thus this function is a constant for all microstates i :

$$p_i = \frac{1}{\Omega}. \quad (10.6)$$

(The sum of the probabilities of all possible states should give unit.)

The constant k should be chosen so that the scale of entropy is identical to that used in phenomenological thermodynamics. Obviously, the zero point of the scale is independent of the choice of k , as the possible minimum of the number of states is 1. We get the well-known entropy scale by choosing the constant as R/N_A , the gas constant divided by the Avogadro constant. It is “the gas constant for a single particle”, $k = 1.3807 \times 10^{-23}$ J/K, and it is called the *Boltzmann constant*. This choice also guarantees that the partial derivative of the function $S(E, V, N)$ is exactly the inverse of temperature, $1/T$, in K units.

10.1.1 Statistical Thermodynamics of the Einstein Solid in Microcanonical Representation

Let us discuss an early example of statistical entropy calculations, the Einstein model of a crystalline solid. In this model, identical particles are localized in each position of the crystal lattice, which are considered as three-dimensional harmonic oscillators with the same ground state frequency ω_0 in the three directions. (This is identical to the assumption that the attractive forces pulling the particle back to the lattice point are proportional to the deflection and are the same in each direction.) The model does not consider different states of the nuclei or electrons but the excitation of the lattice vibrations. The N lattice points are coupled together, thus the entire crystal can have $3N$ collective vibrational modes. The lowest possible frequency is very close to zero (equivalent to a wavelength that fits into the macroscopic crystal), while the highest permissible frequency corresponds to a wavelength comparable to the interparticle distance in the crystal. Following Einstein, this can be modeled by distributing the internal energy U among the $3N$ harmonic oscillators. Each oscillator can have a frequency which is a multiple integer of ω_0 . The energy of a harmonic oscillator is given by,

$$E = \hbar\omega_0 \left(n + \frac{1}{2} \right), \quad (10.7)$$

⁴Boltzmann used the name “thermodynamic probability” (*Wahrscheinlichkeit* in German) for the number of states whence the notation W originally used by him. This has been changed in English to a Greek letter of similar shape and role ω , which in turn got capitalized to become Ω .

where $\hbar = h/2\pi = 1.055 \times 10^{-34}$ Js is *Planck's constant*. Fixing the zero level of energy at $\hbar\omega_0/2$, the energy of the oscillator can assume the discrete values that are multiples of $\hbar\omega_0$ (one vibrational energy quantum), including zero.

The physical model can be “translated” into mathematical language the following way. The internal energy U is available in the form of $U/\hbar\omega_0$ vibrational quanta that can be distributed among the $3N$ oscillators. What is the number of possible states that corresponds to this condition? An equivalent problem is to distribute $U/\hbar\omega_0$ pebbles in $3N$ (distinguishable) boxes. (Lattice points are distinguishable as they are fixed to one single position in the crystal.) This is a simple combinatorial task, but it can be further simplified – as shown in Fig. 10.2.

At the bottom of the figure, we can see the beginning and the end of a possible arrangement of $U/\hbar\omega_0$ indistinguishable pebbles and $3N - 1$ indistinguishable bars in a row. The number of possible arrangements is exactly the same as in case of the original distribution of pebbles in boxes as shown at the top of the figure. Using combinatorial terms, this is the number of permutation of $U/\hbar\omega_0 + 3N - 1$ elements with repetition, where there are $U/\hbar\omega_0$ identical elements of the first kind (pebbles) and $3N - 1$ identical elements of the second kind (bars). From combinatorial identities, we can write this number as:

$$\Omega = P_{\frac{U}{\hbar\omega_0}, 3N-1}^{\frac{U}{\hbar\omega_0} + 3N-1} = \frac{(3N - 1 + \frac{U}{\hbar\omega_0})!}{(3N - 1)! (\frac{U}{\hbar\omega_0})!}. \tag{10.8}$$

We can simplify the notation by introducing $a = 3N - 1$ and $b = U/\hbar\omega_0$, thus the calculation of Ω is equivalent to the calculation of $\frac{(a + b)!}{a!b!}$. As the number of lattice points N is rather large (it is in the order of magnitude of 10^{23}), we can use the Stirling formula to calculate the factorial, which is valid to a good approximation if $N \gg 1$:

$$\ln(N!) = N \ln N - N. \tag{10.9}$$

Fig. 10.2 Three equivalent formal models of the Einstein solid. *First row:* distribution of $U/\hbar\omega_0$ pebbles in $3N$ distinguishable boxes. *Second row:* division of $U/\hbar\omega_0$ indistinguishable pebbles into stacks using $3N - 1$ bars. *Third row:* arrangement of $U/\hbar\omega_0$ indistinguishable pebbles and $3N - 1$ indistinguishable bars in a row

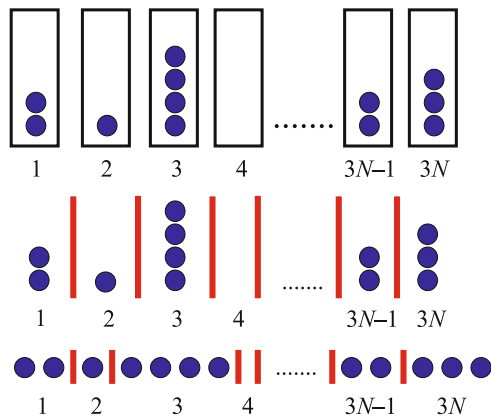

This formula provides the logarithm of the factorial, which readily leads to $\ln \Omega$. Starting with the calculation of the simplified notation, we get:

$$\begin{aligned} \ln \frac{(a+b)!}{a!b!} &= \ln(a+b)! - \ln a! - \ln b! \cong (a+b) \ln(a+b) - a \ln a - b \ln b = \\ &= a[\ln(a+b) - \ln a] - b[\ln(a+b) - \ln b] = a \ln \frac{a+b}{a} + b \ln \frac{a+b}{b} \\ &= a \ln \left(1 + \frac{b}{a}\right) + b \ln \left(1 + \frac{a}{b}\right). \end{aligned} \quad (10.10)$$

Resubstituting a and b , the entropy function can be written as follows:

$$S = 3kN \ln \left(1 + \frac{U}{3N\hbar\omega_0}\right) + \frac{kU}{\hbar\omega_0} \ln \left(1 + \frac{3N\hbar\omega_0}{U}\right). \quad (10.11)$$

Rewriting this N -particle formula for particles of Avogadro-number, we get the (intensive) molar entropy s :

$$s = 3kN_A \ln \left(1 + \frac{u}{3N_A\hbar\omega_0}\right) + \frac{3N_A k u}{3N_A\hbar\omega_0} \ln \left(1 + \frac{3N_A\hbar\omega_0}{u}\right), \quad (10.12)$$

with u being the molar internal energy. Let us substitute R in place of kN_A and u_0 in place of $3N_A\hbar\omega_0$ (i.e., the reference state is the one when every oscillator has an average energy $\hbar\omega_0$). Thus, the molar entropy becomes

$$s = 3R \ln \left(1 + \frac{u}{u_0}\right) + 3R \frac{u}{u_0} \ln \left(1 + \frac{u_0}{u}\right), \quad (10.13)$$

which is a compact form of the fundamental equation of the Einstein solid. Note that this is an *intensive* equation of state, thus it does not contain N as a variable.

Partial derivation of this entropy function with respect to u leads to the inverse temperature. From the function $1/T$, we can express u as a function of temperature. Derivating the u function with respect to T provides the molar heat capacity c_V . Without showing the details of these calculations, we mention that the value of the c_V function thus obtained is zero at $T = 0$ and rises exponentially with temperature until saturation, when it becomes a constant. This constant is identical for many solids with the experimentally determined heat capacity. This tendency is also in accordance with the experiments, thus the thermal properties of the Einstein solid qualitatively reflect the behavior of crystals. However, this is not the case for the mechanical properties; as it can be seen from (10.13), the calculated entropy *does not depend* on volume. Accordingly, the pressure we can calculate as $P = T \left(\frac{ds}{dv}\right)_u$

[see e.g., (2.53)] is zero, which is evidently a contradiction. Thus, the Einstein model of solids cannot be used even qualitatively for mechanical purposes.⁵

10.1.2 Statistical Thermodynamics of a System of Two-State Molecules in Microcanonical Representation

Another example that illustrates the usefulness of statistical thermodynamics in calculating the entropy is a system of a single component consisting of molecules that have a ground state (which is the zero level of energy) and an excited state having a molecular energy ε . There exist similar molecules in reality as well, having two relatively low energy levels, their third and higher energy states having much higher energies so that they are not populated at moderate temperatures. In the corresponding microcanonical ensemble, there are U/ε molecules in the excited state and $N - U/\varepsilon$ molecules in the ground state.

The number of possible states can be calculated using combinatorial considerations. The task is now to determine the number of ways of choosing U/ε molecules out of the N molecules, which is the number of combinations without repetition of U/ε elements chosen from the total number of N elements:

$$\Omega = C_{N, \frac{U}{\varepsilon}} = \frac{N!}{\frac{U}{\varepsilon}!(N - \frac{U}{\varepsilon})!}. \quad (10.14)$$

Let us simplify the notation again by introducing $a = N$ and $b = U/\varepsilon$, thus the calculation of Ω is equivalent to the calculation of $\frac{a!}{b!(a-b)!}$. Let us apply again the Stirling formula for large numbers to approximate the logarithm of their factorial:

$$\ln \frac{a!}{b!(a-b)!} = a \ln a - b \ln b - (a-b) \ln(a-b). \quad (10.15)$$

After some rearrangement and addition of the terms $-b \ln a + b \ln a$ resulting in zero, we get:

$$\begin{aligned} & (b-a) \ln(a-b) - b \ln b + a \ln a - b \ln a + b \ln a \\ &= (b-a) \ln \frac{a-b}{a} - b \ln \frac{b}{a}. \end{aligned} \quad (10.16)$$

⁵Despite this inadequacy, the Einstein solid played an important role in the history of thermodynamics. The experimental evidence already known for a long time that the molar heat capacity of solids changes with temperature could not be explained before. It was Einstein who succeeded to give this explanation by using the results of both quantum mechanics and statistical physics.

Resubstituting N and U/ε , we obtain the expression of entropy:

$$S = k \ln \Omega = \left(\frac{U}{\varepsilon} - N \right) k \ln \left(1 - \frac{U}{N\varepsilon} \right) - \frac{U}{\varepsilon} k \ln \frac{U}{N\varepsilon}. \quad (10.17)$$

Obviously, this entropy function is also independent of volume, thus its mechanical properties are not satisfactory. However, the thermal properties are correct; for example, temperature is always positive, what we can check as follows:

$$\left(\frac{\partial S}{\partial U} \right)_{V,N} = \frac{1}{T} = \frac{k}{\varepsilon} \ln \left(\frac{N\varepsilon}{U} - 1 \right). \quad (10.18)$$

Solving this equation of state for the internal energy U , we get the energy function:

$$U = \frac{N\varepsilon}{1 + e^{\frac{\varepsilon}{kT}}}. \quad (10.19)$$

Obviously, the limit of the exponential when $T \rightarrow \infty$ is unit, and that of the energy is $N\varepsilon/2$. Accordingly, $U \leq (N\varepsilon/2)$, thus the inverse temperature given by (10.18) is nonnegative, which means that the temperature may be positive or zero. It also follows from the result that at very high temperatures, half of the molecules were in the excited state – if higher excited states were not occupied.

Let us write the Avogadro number N_A in the above function to get the *molar internal energy*. By deriving it with respect to T , we get the molar heat capacity:

$$c_V = \left(\frac{\partial u}{\partial T} \right)_{V,N} = N_A \varepsilon \frac{-1}{(e^{\frac{\varepsilon}{kT}} + 1)^2} e^{\frac{\varepsilon}{kT}} \frac{\varepsilon}{k} \left(-\frac{1}{T^2} \right) = \ln \left(\frac{N_A \varepsilon}{U} - 1 \right). \quad (10.20)$$

Resubstituting U and rearranging we obtain

$$c_V = \frac{N_A \varepsilon^2}{kT^2} \frac{e^{\frac{\varepsilon}{kT}}}{(e^{\frac{\varepsilon}{kT}} + 1)^2}. \quad (10.21)$$

Experimental data support that, if the heat capacity function c_V is of the shape predicted by the above equation (see Fig. 10.3), molecules have two low-lying energy levels, and their higher excited states have much higher energy.

It was not only for demonstrative purposes that we discussed such relatively simple systems; in a typical real-life case, combinatorial analogies lead to problems too much difficult where Ω cannot be calculated. There is another possibility to calculate Ω ; the calculation by integrals of points on an isoenergetical surface in multidimensional space modeling the microcanonical systems. However, the integrals thus emerging cannot be calculated in more complicated cases either.

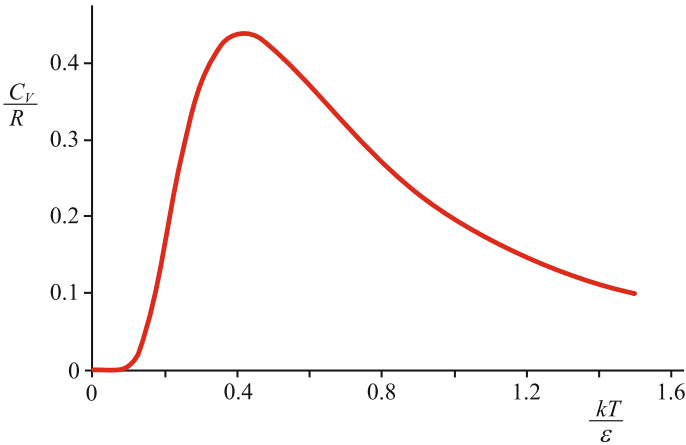

Fig. 10.3 Molar heat capacity c_V in units of R as a function of temperature in units of k/ϵ for a system of two-state molecules

This is the reason to calculate other entropy-like functions instead of entropy itself, over different ensembles than the microcanonical one. As an example, we shall discuss the *canonical ensemble* in the next section.

10.2 The Canonical Ensemble

The (single component) *canonical ensemble*⁶ is the mechanical model of a simple thermodynamic system which is closed, has rigid diathermal walls, and is immersed in a heat reservoir of constant temperature. The reservoir behaves as a thermostat, keeping the temperature of the system constant even if heat would be absorbed or released inside the system. Thus, the canonical ensemble – also called as an N, V, T ensemble – consists of N particles enclosed in a constant volume V , having a constant temperature T . Note that it can have *any energy* which is consistent with these conditions. Accordingly, the elements of the ensemble are replicates of N particles in a fixed volume V that have different energies. (We can also say that the canonical ensemble consists of microcanonical ensembles as elements having the same volume V and particle number N but different energy.) The canonical ensemble can also be considered as a temporal succession of its elements; it is the manifold of particles consistent with the condition of constant N, V , and T , but its successive states – as a consequence of energy exchange with the thermostat – have

⁶The word *canonical* originates from the Greek noun *κανων* (measuring rod; in a figurative sense: rule) via the Latin noun *canon* = rule, whence the Latin adjective *canonicus* = regular. The name *canonical ensemble* was coined by Gibbs, who obviously considered the N, V, T ensemble as “regular” and the N, V, E ensemble as “little regular”. This latter name is an allusion to the property that microcanonical ensembles are included in a canonical ensemble.

a constantly changing energy. The ergodic hypothesis is valid also for this ensemble; the expected values of a random variable of thermodynamic interest over time and that over the ensemble are the same.

Considering the reservoir (including the closed, constant-volume, and constant-temperature inner subsystem) as an isolated system having constant volume, energy and particle number, it can be modeled as a microcanonical ensemble. By doing so, we can reduce the characterization of the canonical ensemble to that of the already known microcanonical ensemble. The most important difference between the microcanonical and canonical ensemble is that the probability of each state is identical in the former, which is no more true in the latter; the probabilities of different states are different. Using combinatorial methods based on the uniform distribution of states inside the reservoir, we can derive the probability distribution over the states in the canonical ensemble included. However, we shall discuss a simple analogy first to illustrate this kind of calculation, and then we will generalize the result for a canonical ensemble.

Let us consider the example of three dice, one of them black and the other two white. The set of two white dice is the analog of the reservoir, the black one corresponds to the “thermostated” system inside. The fixed energy of the entire system containing both reservoir and the constant-temperature subsystem corresponds to a fixed sum when throwing the three dice. We have to determine the conditional probability of the values on the black die provided that the sum on the three dice is always the prescribed value. Let us choose this value to be 12. Table 10.1 summarizes the possible outcomes that fulfill this constraint. The results are grouped according to the value on the black die (the “energy” of the subsystem). As the sum can only be 12 given the actual value of the black die, there are as much possibilities as listed in the second column of the table. We can read from the table that there are altogether 25 different possibilities which have equal probabilities, thus the probability of one actual set of values is $1/25$. Accordingly, the conditional probability of a given number on the black die is $1/25$ times the number of possibilities listed in the second column. This value is written in the column marked “probability.”

The rule explored discussing the above example can be generalized as follows. The probability of the state of a subsystem is equal to the total number of the states

Table 10.1 Conditional probabilities when throwing a black and two white dice provided that the sum on the three dice is always 12

Black die	1st white/2nd white	Possibilities	Probability
1	5/6, 6/5	2	$2/25$
2	5/5, 4/6, 6/4	3	$3/25$
3	3/6, 6/3, 4/5, 5/4	4	$4/25$
4	4/4, 2/6, 6/2, 3/5, 5/3	5	$5/25$
5	1/6, 6/1, 2/5, 5/2, 3/4, 4/3	6	$6/25$
6	3/3, 1/5, 5/1, 2/4, 4/2	5	$5/25$
	Sum	25	1

of the reservoir (without the inner subsystem), compatible with the condition in the case of this particular state, divided by the number of all the possible states (of the entire system) compatible with the condition.

Let us apply this generalized rule for the case shown in Fig. 10.4, when the energy of the subsystem is E_i , and the total energy (of reservoir plus subsystem) is $E_{tot} = E_{res} + E_i$.

Let us denote the microcanonical partition function of the reservoir by Ω_{res} and that of the entire system by Ω_{tot} . The probability p_i that the energy of the inner subsystem is E_i can be calculated in the following way:

$$p_i = \frac{\Omega_{res}(E_{tot} - E_i)}{\Omega_{tot}(E_{tot})}. \quad (10.22)$$

(To simplify notation, we dropped the variables N and V , which does not depend on the index i .)

Let us substitute for Ω_{res} and Ω_{tot} their values expressed as a function of entropy, using the inverted function of (10.5):

$$p_i = \frac{e^{\frac{S_{res}(E_{tot}-E_i)}{k}}}{e^{\frac{S_{tot}(E_{tot})}{k}}} = e^{\frac{S_{res}(E_{tot}-E_i) - S_{tot}(E_{tot})}{k}}. \quad (10.23)$$

Let us denote the equilibrium energy of the inner subsystem (the expected value of energy) as usual by U . Due to the additivity of entropy, we can write:

$$S(E_{tot}) = S(U) + S_{res}(E_{tot} - U). \quad (10.24)$$

Fig. 10.4 An element of a canonical ensemble having energy E_i (*inner system; dashed rectangle*), and the microcanonical ensemble containing it, having a fixed energy $E_{tot} = E_{res} + E_i$ (*entire system; solid rectangle*). The part of the *entire system* outside the *dashed rectangle* serves as an energy reservoir having a constant temperature T_{res} , keeping the temperature of the *inner system* also constant

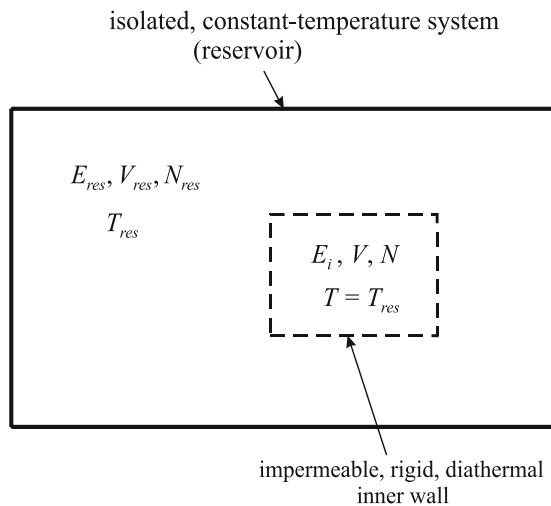

The entropy function $S_{res}(E_{tot} - E_i)$ can be expanded around the energy U :

$$S_{res}(E_{tot} - E_i) = S_{res}(E_{tot} - U + U - E_i) = S_{res}(U) + \frac{\partial S_{res}}{\partial U}(U - E_i) + \dots \quad (10.25)$$

We could write in place of the product of higher order derivatives of S_{res} and the appropriate powers of the difference $(U - E_i)$. However, as the expected value U differs only slightly from the actual energy E_i , the second power of $(U - E_i)$ is already negligibly small compared to $(U - E_i)$ itself, thus we can neglect higher than first-order terms in the power series. This can be easily supported by various arguments. First, we could choose an arbitrarily large reservoir ensuring that $E_{tot} \gg U$, thus $(U - E_i) \ll (E_{tot} + E_i)$ also applies. Second, we know from thermodynamics that $\left(\frac{\partial S}{\partial U}\right)_{V,N} = \frac{1}{T}$, from which it follows that the energy exchanged between the inner system and the reservoir is exactly $\frac{1}{T}dU$. Truncating the power series after the first derivative and writing $\frac{1}{T}$ in place of $\left(\frac{\partial S}{\partial U}\right)_{V,N}$, we get the following equation:

$$S_{res}(E_{tot} - E_i) = S_{res}(E_{tot} - U) + \frac{U - E_i}{T}. \quad (10.26)$$

Using again the additivity of the entropy, we can write the identity:

$$S_{tot}(E_{tot}) = S(U) + S_{res}(E_{tot} - U). \quad (10.27)$$

Let us substitute the above expressions of S_{res} and S_{tot} into the exponent of the expression (10.23) of p_i :

$$S_{res}(E_{tot} - E_i) - S_{tot}(E_{tot}) = \frac{U - E_i}{T} - S(U). \quad (10.28)$$

After some rearrangement, we get the following relation:

$$\frac{U - E_i}{T} - S(U) = \frac{-E_i}{T} + \frac{U - TS(U)}{T}. \quad (10.29)$$

We can clearly see here what we could presuppose from our knowledge of phenomenological thermodynamics; there are no properties concerning either the reservoir or the entire system in this relation, only those concerning the inner system, that is, the canonical ensemble. Substituting the exponents into (10.23), we can write the probability density function we were looking for:

$$p_i = e^{-\frac{E_i}{kT}} \cdot e^{\frac{U - TS(U)}{kT}}. \quad (10.30)$$

Conform to the old habit in statistical thermodynamics, we can somewhat simplify the notation by introducing $\beta = \frac{1}{kT}$. Let us also substitute the well-known function $F = U - TS$. Thus, the probability distribution can be rewritten as:

$$p_i = e^{-\beta E_i} \cdot e^{\beta F}. \quad (10.31)$$

Although we do not know the statistical expression for the free energy function F , all other variables are known from statistical considerations, thus we can express F from the above equation. To this end, let us make use of the fact that the sum of the probability density for the entire sample space (all possible states) is unit by definition, thus:

$$\sum_{\forall i} p_i = e^{\beta F} \cdot \sum_{\forall i} e^{-\beta E_i} = 1. \quad (10.32)$$

Let us introduce the following notation:

$$\sum_{\forall i} e^{-\beta E_i} = Q. \quad (10.33)$$

By inserting this into (10.32) and rearranging, we get:

$$e^{\beta F} = \frac{1}{Q}. \quad (10.34)$$

Taking the logarithm of both sides and rearranging, we obtain:

$$F = -\frac{1}{\beta} \ln Q. \quad (10.35)$$

Let us resubstitute now kT in place of $1/\beta$, and write explicitly the variables which determine Q (and also F):

$$F(T, V, N) = -kT \ln Q(T, V, N). \quad (10.36)$$

This result is the *fundamental equation* determining the function $F(T, V, N)$. Accordingly, (10.36) provides a “prescription” as to the application of the canonical ensemble in statistical thermodynamics: calculate the *canonical partition function*⁷ Q as a function of the states i and the energy of these states E_i ; the free energy F can be readily calculated as a function of Q .

⁷The German name of the canonical partition function is *Zustandsumme*, literally meaning “sum of states,” which has been given by Clausius. Following him, some authors still designate the canonical partition function by Z .

Comparing the relation $e^{\beta F} = 1/Q$ and (10.31), we can write the probability density of the states of the canonical ensemble in a simpler form:

$$p_i = \frac{e^{-\beta E_i}}{\sum_{\forall i} e^{-\beta E_i}} = \frac{1}{Q} e^{-\beta E_i}. \quad (10.37)$$

The function F can also be written in a form similar to the microcanonical entropy. As we can read in the appendix A2.1, the Massieu function $J = -F/T$ is an entropy-like function; it is the partial Legendre-transform of the entropy function $S(U, V, N)$ with respect to the variable U . Thus, we can write from (10.36) its entropy-representation counterpart:

$$-\frac{F}{T} = k \ln Q. \quad (10.38)$$

The structure of this equation is similar to that of (10.5) specifying entropy.

Once we know the canonical probability density function, we can calculate the expectation value of the energy as well:

$$U = \sum_{\forall i} p_i E_i = \sum_{\forall i} \frac{E_i e^{-\beta E_i}}{\sum_{\forall i} e^{-\beta E_i}} = \frac{\sum_{\forall i} E_i e^{-\beta E_i}}{\sum_{\forall i} e^{-\beta E_i}} = -\frac{\partial Q}{\partial \beta} \cdot \frac{1}{Q}. \quad (10.39)$$

In the last step, we have made use of the identity that the derivative of $e^{-\beta E_i}$ with respect to β is $E_i e^{-\beta E_i}$, and that the sum of the derivatives is equal to the derivative of the sum (which is Q). Using the chain rule to change the function to be differentiated for $\ln Q$, we obtain that the expectation value U of the energy is simply the derivative of the function $\ln Q$ with respect to β :

$$U = -\frac{\partial \ln Q}{\partial \beta}. \quad (10.40)$$

As the notations using kT or β occur sometimes alternatively, it is also useful to change from a derivative with respect to β to the one with respect to T . Based on the chain rule and using the identity $T = 1/k\beta$, we can obtain the following relation:

$$\frac{d}{d\beta} = \frac{dT}{d\beta} \frac{d}{dT} = -\frac{1}{k\beta^2} \frac{d}{dT} = -kT^2 \frac{d}{dT}. \quad (10.41)$$

Applying this for the particular case of (10.40), we obtain the internal energy in the following alternative form:

$$U = kT^2 \frac{\partial \ln Q}{\partial T}. \quad (10.42)$$

Note that this can also be obtained from the expression (10.36) applying the well-known thermodynamic relation

$$U = F + TS = F - T \left(\frac{\partial F}{\partial T} \right)_{V,N}. \quad (10.43)$$

10.2.1 Calculation of the Canonical Partition Function from Molecular Data

We have switched to the canonical ensemble to treat thermodynamic problems hoping that the calculation of Q will be simpler than the calculation of Ω on a microcanonical ensemble. To show this simplicity, we have to consider the following. If the states of individual molecules contained in the canonical ensemble are independent of each other, their energy is also independent, thus the energy E_i can be written as the sum of the energies of the (independent) molecular modes ε_i . The condition of this independence is that there should not be any interaction between different modes; that is, the energy of any mode should be independent of the occupancy of other modes. Using a simple and (hopefully) easy-to-follow notation, this additivity can be written as:

$$E_i = \varepsilon_1(j_1) + \varepsilon_2(j_2) + \varepsilon_3(j_3) \cdots + \varepsilon_N(j_N). \quad (10.44)$$

Here, j_1, j_2, \dots, j_N denote the state of individual molecules and $\varepsilon_i(j_i)$ is their energy in the element of the canonical ensemble whose energy is E_i . Putting j_i -s as subscripts, the partition function can be written as:

$$Q = \sum_{\forall i} e^{-\beta E_i} = \sum_{\forall j_k} e^{-\beta \varepsilon_{1j_1} - \beta \varepsilon_{2j_2} - \dots - \beta \varepsilon_{Nj_N}} = \sum_{\forall j_k} (e^{-\beta \varepsilon_{1j_1}} \cdot e^{-\beta \varepsilon_{2j_2}} \cdot \dots \cdot e^{-\beta \varepsilon_{Nj_N}}). \quad (10.45)$$

The sum of the products of exponential functions can be written as the product of the sum of exponential functions:

$$\sum_{\forall j_k} (e^{-\beta \varepsilon_{1j_1}} \cdot e^{-\beta \varepsilon_{2j_2}} \cdot \dots \cdot e^{-\beta \varepsilon_{Nj_N}}) = \left(\sum_{j_1=1}^{M_1} e^{-\beta \varepsilon_{1j_1}} \right) \left(\sum_{j_2=1}^{M_2} e^{-\beta \varepsilon_{2j_2}} \right) \cdots \left(\sum_{j_N=1}^{M_N} e^{-\beta \varepsilon_{Nj_N}} \right). \quad (10.46)$$

The summations with respect to j_1, j_2, \dots, j_N are done for the molecular states of each molecule from 1 to M_1, M_2, \dots, M_N ; that is, for all the possible states of the molecules. (For identical molecules, these limits are obviously identical, but for a

multicomponent system, they are identical for the same species only. This offers the possibility to extend statistical thermodynamics for multiple component systems.)

Let us denote the sums in parentheses by q_k and call them as the *molecular partition functions* of the species k :

$$q_k = \sum_{\forall j} e^{-\beta \epsilon_{kj}}. \quad (10.47)$$

With the help of this molecular partition function, we can write the partition function of the canonical ensemble using (10.45) and (10.46):

$$Q = \prod_{k=1}^N q_k. \quad (10.48)$$

We can state that the partition function of the *ensemble* can be obtained as the product of the *molecular* partition functions calculated on the basis of the assumption of independent molecular modes.

10.2.2 Statistical Thermodynamics of the Einstein Solid and the System of Two-State Molecules in Canonical Representation

Using the previously discussed examples, we shall demonstrate the simplicity of thermodynamic calculations in the canonical representation compared to that in the microcanonical representation. Let us treat again the Einstein solid. The energy of vibrational molecular modes in this model is $n\hbar\omega_0$, with n running from 0 to infinity. As vibrations are the only possible modes, the molecular partition function can be written as:

$$q = \sum_{n=0}^{\infty} e^{-n\beta\hbar\omega_0}. \quad (10.49)$$

The sum is exactly that of a geometric series with a quotient $e^{-\beta\hbar\omega_0}$:

$$q = \frac{1}{1 - e^{-\beta\hbar\omega_0}}. \quad (10.50)$$

The vibrational modes are independent of each other, thus we can calculate the total partition function of the ensemble as the product of the $3N$ identical molecular partition functions:

$$Q = \left(\frac{1}{1 - e^{-\beta\hbar\omega_0}} \right)^{3N}. \quad (10.51)$$

From this, we can readily calculate the fundamental equation providing the free energy function F :

$$F = -kT \ln Q = 3NkT \ln(1 - e^{-\beta\hbar\omega_0}) = 3nRT \ln\left(1 - e^{-\frac{\hbar\omega_0}{kT}}\right). \quad (10.52)$$

Based on the thermodynamic relation $S = -(dF/dT)_{V,N}$, we can also calculate the entropy function what is identical to that obtained for the extensive entropy from (10.12):

$$S = 3kN \ln\left(1 + \frac{U}{3N\hbar\omega_0}\right) + \frac{kU}{\hbar\omega_0} \ln\left(1 + \frac{3N\hbar\omega_0}{U}\right). \quad (10.53)$$

From the above discussion, it is obvious that the calculation of F is much simpler in the canonical representation than the calculation of entropy in the microcanonical representation. We can also recognize that, if there were not only one possible frequency in the crystal but more, the combinatorial calculations were rather complicated, while the canonical partition function is easy to calculate.

Let us discuss now the other previous example, the two-state system in the canonical representation. In this case, all molecules have two states whose occupancies are independent of each other. The energy of the ground state is 0, while that of the excited state is ε . Accordingly, we can write the molecular partition function as follows:

$$q = \sum_{i=1}^2 e^{-\frac{\varepsilon_i}{kT}} = e^0 + e^{-\frac{\varepsilon}{kT}}. \quad (10.54)$$

From this, the partition function of the ensemble is easy to obtain:

$$Q = q^N = (1 + e^{-\frac{\varepsilon}{kT}})^N. \quad (10.55)$$

The corresponding equation of state can be written as:

$$F = -kT \ln Q = -NkT \ln(1 + e^{-\frac{\varepsilon}{kT}}). \quad (10.56)$$

Using thermodynamic relations, we can get other potential functions as well. For the internal energy, we have:

$$U = -\frac{\partial \ln Q}{\partial \beta} = -N \frac{1}{1 + e^{-\beta\varepsilon}} (-\varepsilon)e^{-\beta\varepsilon} = \frac{N\varepsilon e^{-\beta\varepsilon}}{(1 + e^{-\beta\varepsilon})}. \quad (10.57)$$

From this, we can deduce the entropy function according to the relation:

$$S = -\frac{F}{T} + \frac{U}{T} = -\frac{F}{T} - \frac{1}{T} \frac{\partial \ln Q}{\partial \beta}. \quad (10.58)$$

Substituting the above expression of U into (10.58), we readily get the entropy function:

$$S = Nk \ln\left(1 + e^{-\frac{\epsilon}{kT}}\right) + \frac{N\epsilon}{T} \frac{e^{-\frac{\epsilon}{kT}}}{\left(1 + e^{-\frac{\epsilon}{kT}}\right)}. \quad (10.59)$$

It is obvious also in this case that, if there were 3 (4, 5, etc.) accessible states for the molecules instead of 2, combinatorial calculations were quite involved, while the canonical partition function and hence the fundamental equation providing the function $F(T, V, N)$ is easy to calculate in these cases as well.

10.2.3 The Translational Partition Function. Statistical Thermodynamics of a Monatomic Ideal Gas

Gas molecules can have the following modes: translational modes, rotational modes, vibrational modes, and electronic modes. (We could consider in principle also *nuclear modes*, but to change their state would need enormous amounts of energy, which is not available at normal earthly conditions, thus we do not need to take them into account.)

Provided that the mentioned four modes of gas molecules are independent from each other, the partition function of the canonical ensemble can be factorized in a form $Q^{\text{trans}} \times Q^{\text{rot}} \times Q^{\text{vib}} \times Q^{\text{el}}$. Obviously, the molecular partition function can be factorized the same way: $q^{\text{trans}} \times q^{\text{rot}} \times q^{\text{vib}} \times q^{\text{el}}$, and the partition function of the ensemble can be calculated from this function. Consequently, to get the partition function, we can first calculate the molecular translational, rotational, vibrational, and electronic partition functions as its contributions.

Let us begin with the translational contribution. In an ideal gas, translational energies of the molecules are independent of each other, thus it is sufficient (in a single-component system) to consider the translational states and their energies. From quantum mechanics, we have the solution of the problem “particle in a box”. For a one-dimensional box of length L , the translational energy is

$$\epsilon_n = \frac{n^2 h^2}{8mL^2}, \quad (10.60)$$

where the quantum number n – an integer number – runs from 1 to infinity. Let us choose the energy scale so that the lowest energy level ($n = 1$) be zero. Let us denote this energy by ε , whose value is:

$$\varepsilon = \frac{h^2}{8mL^2}. \quad (10.61)$$

As this is the zero of the energy scale, the energy depending on then translational quantum number n can be written as $\varepsilon_n = (n^2 - 1)\varepsilon$, and the molecular translational partition function as:

$$q_{1D}^{\text{trans}} = \sum_{n=1}^{\infty} e^{-\beta(n^2-1)\varepsilon}. \quad (10.62)$$

Translational energy levels are very much close to each other in a macroscopic system, thus we can consider the quantum number n as a continuous variable and can replace the summation by integration:

$$q_{1D}^{\text{trans}} = \int_1^{\infty} e^{-\beta(n^2-1)\varepsilon} dn = \int_0^{\infty} e^{-\beta n^2 \varepsilon} dn. \quad (10.63)$$

To evaluate the integral, let us change the variable according to the substitution $x^2 = \beta n^2 \varepsilon$, from which n can be explained as $n = x/\sqrt{\beta\varepsilon}$. Using the relation

$$\frac{dn}{dx} = \frac{1}{\sqrt{\beta\varepsilon}}, \quad (10.64)$$

we can substitute $dx/\sqrt{\beta\varepsilon}$ in place of dn , thus we can write:

$$q_{1D}^{\text{trans}} = \int_0^{\infty} e^{-x^2} \frac{dx}{\sqrt{\beta\varepsilon}} = \sqrt{\frac{1}{\beta\varepsilon}} \cdot \frac{\sqrt{\pi}}{2} = \sqrt{\frac{\pi}{4\beta\varepsilon}}. \quad (10.65)$$

(We have substituted the value of the improper integral of the function e^{-x^2} between 0 and infinity, which is $\sqrt{\pi}/2$.) Resubstituting the expression (10.61) of ε , we get the *one-dimensional molecular translational partition function*:

$$q_{1D}^{\text{trans}} = \sqrt{\frac{2\pi m}{h^2\beta}} \cdot L = \sqrt{\frac{2\pi mkT}{h^2}} \cdot L. \quad (10.66)$$

From this expression, we can derive the three-dimensional translational partition function, knowing that the kinetic energy of the translational motion in one

direction is independent from those in perpendicular directions. Thus – denoting the length of the edges of a three-dimensional box by X , Y and Z – the kinetic energies of motions in perpendicular directions add as $\varepsilon_{n_x, n_y, n_z} = \varepsilon_{n_x} + \varepsilon_{n_y} + \varepsilon_{n_z}$ and the three-dimensional translational partition function is the product of the one-dimensional partition functions; $q^{\text{trans}} = q_x \times q_y \times q_z$:

$$q^{\text{trans}} = \left(\frac{2\pi m k T}{h^2} \right)^{3/2} \cdot V, \quad (10.67)$$

where $V = XYZ$ is the volume of the box. The result is valid for a box of any shape, only the volume V matters. Let us introduce the symbol Λ for the *thermal wavelength*:

$$\Lambda = \frac{h}{\sqrt{2\pi m k T}}. \quad (10.68)$$

Applying this notation, the molecular translational partition function can be written in the short form:

$$q^{\text{trans}} = \frac{V}{\Lambda^3}. \quad (10.69)$$

The value of the molecular translational partition function is quite large; in a gas of 100 cm^3 containing O_2 molecules at 25°C , $\Lambda = 17.8 \text{ pm}$ and q^{trans} has the value of 1.773×10^{30} .

In monatomic gases (e.g., noble gases), there are no other motions of molecules possible but translation. Their electronically excited states are available only at very high energies, thus we can easily calculate the fundamental equation of a monatomic ideal gas at not too high temperatures.

Following the procedure explained before to get the partition function Q , we should calculate the product of the molecular partition functions of N molecules. However, this would yield an enormously large number of which we can easily see that it is not the correct value. The previously derived calculation is namely valid only for *distinguishable* molecules – as for example in a crystal where individual molecules are localized. Gas molecules can freely move. Thus, if we interchange two molecules, it is still the same state; consequently, we do not count it as a distinct state. This suggests that the result of the products of molecular partition functions should be divided by the number of the possible interchanges of molecules that do not lead to a new state. In a gas, this is the number of permutations without repetition of N elements, that is, $N!$. Thus, the proper canonical partition function of a pure monatomic ideal gas containing N atoms is⁸:

⁸Calculating the partition function with quantum-mechanical methods for the macroscopic states, the number of states will be correct; we do not need to include an extra division by $N!$.

$$Q = \frac{1}{N!} (q^{\text{trans}})^N = \frac{V^N}{N!} \left(\frac{2\pi mkT}{h^2} \right)^{\frac{3N}{2}}. \quad (10.70)$$

To calculate the fundamental equation, let us express the logarithm of the partition function applying the usual Stirling formula:

$$\ln Q = N \ln V - N \ln N + N + N \ln \left(\frac{2\pi mkT}{h^2} \right)^{3/2}. \quad (10.71)$$

Rearranging and multiplying by $-kT$ we get the fundamental equation:

$$F(T, V, N) = -NkT \left[1 + \ln \left(\frac{V}{N} \left[\frac{2\pi mkT}{h^2} \right]^{3/2} \right) \right]. \quad (10.72)$$

To obtain the equations of state, let us apply usual thermodynamic relations:

$$P = - \left(\frac{\partial F}{\partial V} \right)_{T,N} = NkT \frac{1}{V} = \frac{nRT}{V}. \quad (10.73)$$

$$S = - \left(\frac{\partial F}{\partial T} \right)_{V,N} = nR \left[\frac{5}{2} + \ln \left(\frac{V}{N} \left[\frac{2\pi mkT}{h^2} \right]^{3/2} \right) \right]. \quad (10.74)$$

Differentiating the function $F(T, V, N)$ with respect to N yields the chemical potential referred to *one single particle*, thus we need to multiply it by the Avogadro constant to get the familiar molar value:

$$\mu = N_A \left(\frac{\partial F}{\partial N} \right)_{T,V} = -RT \ln \left(\left[\frac{2\pi mkT}{h^2} \right]^{3/2} \right). \quad (10.75)$$

The internal energy can be calculated using the relation $U = F + TS$, leading to the entropy-based thermal equation of state:

$$U = \frac{3}{2} nRT. \quad (10.76)$$

Inverting this function, we get the temperature T as a function of U :

$$T = \frac{2U}{3nR} = \frac{2U}{3Nk}. \quad (10.77)$$

The rationale behind this is that the wave function for the macroscopic state does not change when interchanging coordinates of gas molecules, thus it is the same state.

Inserting this in the expression (10.74) of entropy, we get the fundamental equation specifying the function $S(U, V, N)$:

$$S(U, V, N) = nR \left[\frac{5}{2} + \ln \left(\frac{V}{N} \left[\frac{4\pi m U}{3h^2 N} \right]^{3/2} \right) \right]. \quad (10.78)$$

This relation is called the *Sackur–Tetrode*⁹ equation, commemorating the two scientists who first derived it. It is worth mentioning that the derivative of the right-hand side of (10.76) with respect to T provides the constant-volume heat capacity of the monatomic ideal gas

$$C_V = n \frac{3}{2} R, \quad (10.79)$$

which is also in accordance with experimental results.

10.2.4 Calculation of the Rotational, Vibrational, and Electronic Partition Functions

The calculation of other contributions to the partition function can be performed similarly to the method we used to calculate the translational contribution. Thus, to calculate the *rotational partition function*, we need to know the energy of molecular rotations. The energy of a linear (rigid) heteronuclear rotor – for example, an HCl molecule – can be calculated using quantum mechanics. The *rotational constant* is

$$B = \frac{h}{8\pi^2 c I}, \quad (10.80)$$

where I is the *moment of inertia* and c the velocity of light in vacuum. The energy of the rotor can be written as

$$\varepsilon^B(J) = hcBJ(J+1), \quad (10.81)$$

whence the corresponding partition function is

$$q_{\text{lin}}^R = \sum_{J=0}^{\infty} (2J+1) e^{-\beta hcBJ(J+1)}. \quad (10.82)$$

⁹Hugo Martin Tetrode (1895–1931) Dutch theoretical physicist and Otto Sackur (1880–1914) German chemist independently derived the fundamental equation of the monatomic ideal gas and published their results in 1912. The result was named later after the two scientist. (Both died at an early age; the cause was tuberculosis for Tetrode and an unexpected explosion while developing explosives to be used in a grenade for Sackur.)

An unusual feature of this result is the factor $(2J + 1)$ appearing in the sum; we did not have anything similar in the calculations before. The reason for this factor is the following. When calculating the partition function, we sum with respect to the index J , which is the *rotational quantum number*. It is known from the quantum-mechanical description of rotation that energy levels belonging to the same rotational quantum number J have a *degeneracy* of $2J + 1$. This means that there are $2J + 1$ rotational states of energy $\varepsilon^B(J)$ at the same energy level, sharing the same quantum number J . The partition function is defined as the sum over *states*, thus all these $2J + 1$ rotational states should be added to the sum. However, as their energy is the same, we can write one exponential term having the exponent of $-\varepsilon^B(J)$, multiplied by $(2J + 1)$, the degeneracy of the energy level. (The procedure is similar in case of other degenerate levels.)

To calculate the sum, we approximate it again with an integral. This can be done if $hcB \ll kT$, (hcB is the energy of the ground state, $J = 0$); in this case, the values of the exponential functions with neighboring J are so close to each other that the integrand can be considered as a continuous function of J . Let us rewrite the summation as an integral, make the substitution $J(J + 1) = x$, from which $dx/dJ = 2J + 1$, i.e., $dJ = dx/(2J + 1)$. Thus:

$$q_{\text{lin}}^R = \int_0^{\infty} (2J + 1) e^{-\beta hc B J(J+1)} dJ = \int_0^{\infty} (2J + 1) e^{-\beta hc B x} \frac{dx}{2J + 1}. \quad (10.83)$$

The integration can readily be done:

$$\int_0^{\infty} e^{-\beta hc B x} dx = \left[-\frac{1}{\beta hc B} e^{-\beta hc B x} \right]_0^{\infty} = 0 + \frac{1}{\beta hc B}. \quad (10.84)$$

Thus, the molecular partition function of the linear rotor is

$$q_{\text{lin}}^R = \frac{kT}{hcB}. \quad (10.85)$$

The heteronuclear linear rotor (e.g., the molecule HCl) has two rotational degrees of freedom. Accordingly, it has two independent rotational axes, with the same rotational constant, thus the same rotational energy.

A general rotor (e.g., a multiatomic molecule) has three rotational degrees of freedom, thus three independent rotational axes. Let us denote the corresponding rotational constants by A , B , and C . The rotational partition function of the general multiatomic molecule can then be written as:

$$q^R = \frac{1}{\sigma} \left(\frac{kT}{hc} \right)^{3/2} \sqrt{\frac{\pi}{ABC}}. \quad (10.86)$$

The Greek letter σ denotes the *rotational symmetry factor* of the molecule. Its significance is that, when the molecule rotates through $360^\circ/\sigma$, it results in a configuration that is indistinguishable from the one from which it started, and the same configuration occurs σ times during a complete rotation. These identical configurations cannot be considered as different states; therefore, the number of states is less, and thus the partition function should also be diminished. For the ammonia molecule, $\sigma = 3$, while for the methane molecule, it is 12, as this molecule has four threefold rotational axes. Note that, for a *homonuclear* linear rotor, two indistinguishable rotational states occur through 180° rotations. Thus, (10.85) should be modified by a division by 2 if applied for such molecules.

At ambient temperatures, many rotational excited states are occupied. Accordingly, the rotational partition function is typically of the order of magnitude of a few thousands.

The *vibrational partition function* can also be written based on the vibrational energies calculated from quantum mechanics. The energy of a harmonic oscillator can be written as

$$\varepsilon_v = \left(v + \frac{1}{2} \right) h\nu, \quad (10.87)$$

where the Latin letter v is the *vibrational quantum number*, while the Greek letter ν is the frequency of vibration. (This can be the solution of the Schrödinger equation of the molecular oscillator, or it can be determined experimentally by infrared spectroscopy.) By choosing the zero of the energy scale as

$$\varepsilon_0 = \frac{1}{2} h\nu = 0, \quad (10.88)$$

the energy of the oscillator having the quantum number v is $\varepsilon_v = v h\nu$ and the partition function

$$q^V = \sum_{v=0}^{\infty} e^{-\beta v h\nu} = \sum_{v=0}^{\infty} \left(e^{-\frac{h\nu}{kT}} \right)^v. \quad (10.89)$$

We can recognize that – similarly to (10.49) – this is a geometric series with the quotient $e^{-\frac{h\nu}{kT}}$. The sum of the series is the molecular partition function of the vibration of frequency ν :

$$q^V = \frac{1}{1 - e^{-\frac{h\nu}{kT}}}. \quad (10.90)$$

The partition function has the same form for each (harmonic) normal vibration, thus the total vibrational partition function can be written as

$$q^V = q^V(1) \cdot q^V(2) \cdot \dots \cdot q^V(k), \quad (10.91)$$

where the k multiplicative terms comprise all the possible normal vibrational modes of the molecule. A molecule consisting of N atoms can be considered as a system of N point masses, thus it has $3N$ degrees of freedom. Of these, 3 is translational, 2 is rotational in case of a linear molecule, but it is 3 for a nonlinear multiatomic molecule. Consequently, a molecule has $3N - 5$ vibrational degrees of freedom if it is linear, and $3N - 6$ if it is nonlinear; that is, so many normal vibrational modes. Vibrational excited states have much larger energy level spacing than rotational ones, thus the value of $q^V(i)$'s at ambient temperatures is in the range 1–3.

The *electronic partition function* of molecules can also be calculated knowing the energy of the electronic ground state and the excited states. For the majority of molecules, the electronically excited state is so high that its contribution at ambient and not too much higher temperatures can be neglected to the partition function. As a result, we can assume that $q^E = 1$, except for molecules whose electronic ground state is degenerated. For these latter, the molecular electronic partition function is identical to the *electronic degeneracy*:

$$q^E = g^E. \quad (10.92)$$

An interesting exception from this rule is the case of molecules whose excited electronic states' energy is very much close to that of the ground state. For example, the NO molecule has two degenerate ground states and two degenerate excited states with only slightly higher energy. Considering its ground state energy as the zero level, its molecular electronic partition function can be written as

$$q_{\text{NO}}^E = 2 + 2e^{-\frac{\varepsilon^*}{kT}}, \quad (10.93)$$

where ε^* is the energy of the excited state with respect to the ground state. (Using the same nomenclature as for the two-state system, we could call this as a “double-degenerate two-state system”.)

Having calculated all the contributions to the molecular partition function in an ideal gas, we can write the partition function of the ensemble in the following form:

$$Q = \frac{1}{N!} (q^T \cdot q^R \cdot q^V \cdot q^E)^N. \quad (10.94)$$

If the ideal gas consists of K components, where there are N_j molecules of component j in the ensemble modeling the gas, the partition function can be written as:

$$Q = \prod_{j=1}^K \frac{1}{N_j!} (q_j^T \cdot q_j^R \cdot q_j^V \cdot q_j^E)^{N_j}. \quad (10.95)$$

This formula can be used to calculate polyatomic, multicomponent ideal gases as well. Of course, the actual form of the molecular partition function depends on the structure of molecules.

10.2.5 Statistical Characterization of the Canonical Energy

Using the canonical probability density function (10.37),

$$p_i = \frac{e^{-\frac{E_i}{kT}}}{\sum e^{-\frac{E_i}{kT}}},$$

we have calculated the expectation value of the energy (the internal energy). According to (10.40), this can be given as

$$M(E) = U = -\frac{\partial \ln Q}{\partial \beta}.$$

With the help of the probability density function, we can also calculate the variance of the internal energy. By definition, this is the expectation of the square of deviation from the expectation of the energy, and can be written as:

$$\sigma^2(E) = M([E - M(E)]^2) = M(E^2 - 2EM(E) + [M(E)]^2) = M(E^2) - [M(E)]^2. \quad (10.96)$$

Using the definition of the expectation value, we can calculate this the following way:

$$\sigma^2(E) = \sum E_i^2 \frac{e^{-\beta E_i}}{Q} - \left(\sum E_i \frac{e^{-\beta E_i}}{Q} \right)^2. \quad (10.97)$$

The second term in this equation is the square of the expectation value that we already know:

$$U^2 = \left(-\frac{\partial \ln Q}{\partial \beta} \right)^2 = \frac{1}{Q^2} \left(\frac{\partial Q}{\partial \beta} \right)^2. \quad (10.98)$$

Taking into account the identity $Q = \sum e^{-\beta E_i}$, we can see that

$$\frac{\partial^2 Q}{\partial \beta^2} = \sum E_i^2 e^{-\beta E_i}, \quad (10.99)$$

thus we can write for the variance:

$$\sigma^2(E) = \frac{1}{Q} \frac{\partial^2 Q}{\partial \beta^2} - \frac{1}{Q^2} \left(\frac{\partial Q}{\partial \beta} \right)^2. \quad (10.100)$$

It can be seen that this is exactly the derivative of $M(E) = U$:

$$\frac{\partial M(E)}{\partial \beta} = \frac{\partial}{\partial \beta} \left(-\frac{\partial \ln Q}{\partial \beta} \right) = \frac{\partial}{\partial \beta} \left[-\frac{1}{Q} \frac{\partial Q}{\partial \beta} \right] = -\frac{1}{Q} \frac{\partial^2 Q}{\partial \beta^2} + \frac{1}{Q^2} \frac{\partial Q}{\partial \beta} \frac{\partial Q}{\partial \beta}. \quad (10.101)$$

As a conclusion, we can write the variance of energy in the following form:

$$\sigma^2(E) = -\frac{\partial M(E)}{\partial \beta} = -\frac{\partial U}{\partial \beta}. \quad (10.102)$$

By changing from the derivation with respect to β to the derivation with respect to T , as shown in (10.41), we can rewrite this as:

$$\sigma^2(E) = kT^2 \left(\frac{\partial U}{\partial T} \right)_{V,N} = kT^2 N c_V. \quad (10.103)$$

The standard deviation (or *mean fluctuation*) of the energy is the square root of the above expression. Thus, we can write the *fluctuation relative to the expectation value* as:

$$\frac{\sigma}{M(E)} = \frac{\sqrt{\sigma^2}}{U} = \frac{1}{U} \sqrt{kT^2 N c_V}. \quad (10.104)$$

The extensive internal energy U in the denominator is proportional to the particle number N , thus the relative fluctuation is inversely proportional to the square root of N . With increasing N , U increases proportionally, while its relative fluctuation decreases proportionally to $1/\sqrt{N}$. As the particle number goes to infinity, the relative fluctuation of energy goes to zero. Recalling that energy is fixed in a microcanonical ensemble, we can state that in case of sufficiently large number of particles, thermodynamic properties calculated on a canonical ensemble should be the same as those calculated on a microcanonical ensemble. Let us see what is the number of particles above, of which we can neglect the canonical fluctuation of energy.

In a body of macroscopic size, the number of particles is of the order of magnitude of 10^{23} , whose square root is greater than 10^{11} . Accordingly, the fluctuation (or “uncertainty”) of an internal energy of 100 kJ/mol is less than 10^{-9} kJ/mol, or 0.000000001 kJ/mol. This difference is so small that it cannot be determined using macroscopic methods; thus, the energy fluctuation can be neglected macroscopically.

We have stated that the canonical distribution over the states i is an exponential function of the energies of these states E_i :

$$p_i = \frac{e^{-\frac{E_i}{kT}}}{Q}.$$

Let us calculate from this the multiparticle energy distribution (independently of the microstate of the ensemble, the distribution of the *energy* only). The value of the microcanonical partition function $\Omega(E)$ means that the element of the canonical ensemble in which the energy is exactly E can be realized in $\Omega(E)$ different microstates. In other words, the energy level E has an $\Omega(E)$ -fold degeneracy. Consequently, we should add that much (equal) probability contributions to get the probability density of energy E :

$$P(E) = \Omega(E) \frac{e^{-\beta E}}{Q} \tag{10.105}$$

The quantity $\Omega(E)$ is called the *density of states* in this respect, and it is proportional to E^N . Thus, concerning the probability of a macroscopic energy E , it contains the constant factor $1/Q$, the density of states $\Omega(E)$ (a rapidly increasing function of energy) and the Boltzmann factor $e^{-\beta E}$ (a rapidly decreasing function of energy). The probability density function of the macroscopic energy E is the product of these two functions divided by Q ; it is a very sharp peak at the intersection of the rapidly increasing/decreasing functions close to their zero values. As this function emerges as a result of a large number of means of molecular energy-distributions, according to the central limit theorem, it is normally distributed, thus has the shape of a Gaussian function.

Note that while the probability density function of the multiparticle energy (i.e., the macroscopic energy of the canonical ensemble) is the sharp peak shown in Fig. 10.5, the (nondegenerate) energy levels of individual particles are distributed according to the Boltzmann distribution. In terms of the molecular energy ε_i , this can be written as:

$$p(\varepsilon_i) = \frac{1}{q} e^{-\frac{\varepsilon_i}{kT}}. \tag{10.106}$$

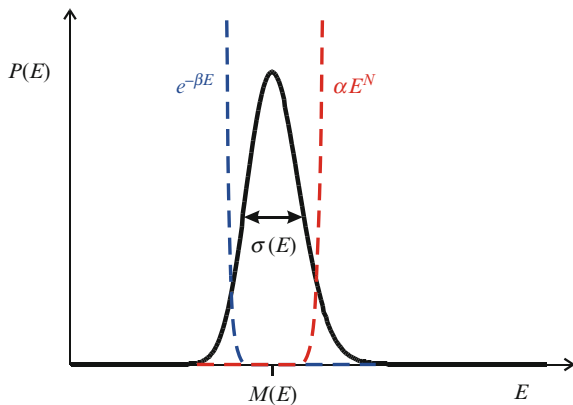

Fig. 10.5 Probability density function $P(E)$ of the multiparticle energy in a canonical ensemble

Fig. 10.6 Probability density function $p(\varepsilon_i)$ of the single-particle energy in a canonical ensemble

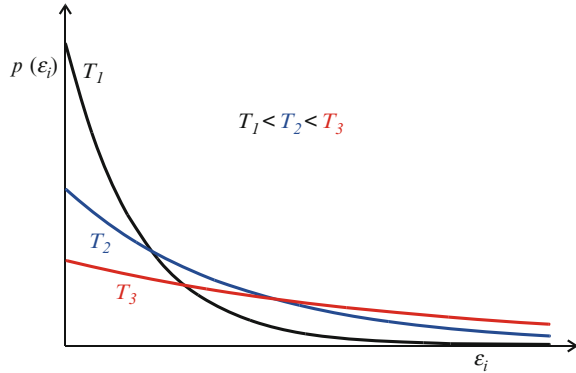

Figure 10.6 shows the density function of the single-particle energy at three different temperatures. As we can expect, lower-energy states are more populated at lower temperature, while increasing the temperature, higher-energy states get more and more populated. (At infinitely high temperature, the distribution would have been uniform.) The integral of the probability density function should be always unit, thus the continuous curves are lower at high temperatures close to zero energy, and higher at low temperatures. If the distribution is discrete, the sum of the possible discrete values should give unit. Thus, their height might change if the “norm” q changes, but their ratio is always the same at two different but fixed energies ε_i and ε_j :

$$\frac{p(\varepsilon_i)}{p(\varepsilon_j)} = \frac{e^{-\frac{\varepsilon_i}{kT}}}{e^{-\frac{\varepsilon_j}{kT}}} = e^{-\frac{\varepsilon_i - \varepsilon_j}{kT}}. \quad (10.107)$$

This ratio is the same for each particle, thus the above ratio also holds for the *number* of corresponding particles:

$$\frac{N(\varepsilon_i)}{N(\varepsilon_j)} = e^{-\frac{\varepsilon_i - \varepsilon_j}{kT}}. \quad (10.108)$$

10.2.6 The Equipartition Theorem

The distribution of energy over the molecular degrees of freedom has an interesting general property. To explore this property, let us calculate the expectation value of the energy of different molecular modes in analogy of (10.40), using the single-particle energy distribution (10.106):

$$M(\varepsilon_i) = \sum \varepsilon_i p_i = -\frac{\partial \ln q}{\partial \beta}. \quad (10.109)$$

For the translational mode of 3 degrees of freedom, the molecular partition function can be written as:

$$q^T = \left(\frac{2\pi m kT}{h^2} \right)^{3/2} V = \left(\frac{2\pi m}{\beta h^2} \right)^{3/2} V. \quad (10.110)$$

By derivation with respect to β , we obtain the result:

$$-\frac{\partial \ln q^T}{\partial \beta} = -\frac{\partial}{\partial \beta} \left[\ln V + \frac{3}{2} \ln \frac{2\pi m}{h^2} - \frac{3}{2} \ln \beta \right] = \frac{3}{2} \frac{1}{\beta} = \frac{3}{2} kT. \quad (10.111)$$

For the linear rotor of 2 rotational degrees of freedom, the molecular partition function has the form

$$q^R = \frac{kT}{hcB} = \frac{1}{\beta} \cdot \frac{1}{hcB}, \quad (10.112)$$

from which the expectation value of the energy is the following:

$$-\frac{\partial \ln q^R}{\partial \beta} = -\frac{\partial}{\partial \beta} [-\ln \beta - \ln(hcB)] = \frac{1}{\beta} = kT. \quad (10.113)$$

For the molecular vibration of 1 vibrational degree of freedom, the molecular partition function is

$$q^V = \frac{1}{1 - e^{-\frac{hv}{kT}}} = \frac{1}{1 - e^{-\beta hv}}, \quad (10.114)$$

which leads to the expectation value of energy as follows:

$$-\frac{\partial \ln q^V}{\partial \beta} = -\frac{\partial}{\partial \beta} [-\ln(1 - e^{-\beta hv})] = \frac{1}{1 - e^{-\beta hv}} \cdot hve^{-\beta hv} = \frac{hv}{e^{\beta hv} - 1} = \frac{hv}{e^{\frac{hv}{kT}} - 1}. \quad (10.115)$$

Comparing this result to the expectation of translational and rotational energy, we can see that these latter are multiples of kT , while the expectation of the vibrational energy has a different form. However, if $kT \gg hv$, the exponent in the function is much less than unit, thus we can replace the function to a good approximation by its power series, dropping higher than first-order terms. The approximation can be written as $e^{\beta hv} \cong 1 + \beta hv$, from which the expectation of the vibrational energy can be calculated in the following form:

$$\frac{hv}{1 + \beta hv - 1} = \frac{1}{\beta} = kT. \quad (10.116)$$

Table 10.2 Expectation value of the energy of different molecular modes as a function of temperature

Molecular mode	Classical mechanical expression for the energy	Expectation of energy	Expressed in terms of degrees of freedom
Translation	$\frac{1}{2}m(v_x^2 + v_y^2 + v_z^2)$	$\frac{3}{2}kT$	$3 \cdot \frac{1}{2}kT$
Rotation	$\frac{1}{2}(I_1\omega_1^2 + I_2\omega_2^2)$	$\frac{2}{2}kT$	$\nu^R \cdot \frac{1}{2}kT$
Vibration	$\frac{1}{2}(mv_x^2 + kx^2)$	$\frac{2}{2}kT$	$2\nu^V \cdot \frac{1}{2}kT$

Thus, applying the high-temperature approximation, the expectation of the vibrational energy is also kT , provided that the vibrational energy $h\nu$ is much less than kT .

Let us summarize the above results in Table 10.2, showing also classical mechanical expressions for the calculation of the energy of respective motions. Writing the expectation value of the energy as multiples of $\frac{1}{2}kT$, we can observe that it is the product of the number of degrees of freedom and $\frac{1}{2}kT$ for translation and rotation, while it is twice this value for vibration.

Observing the classical mechanical expressions for the calculation of the respective energy, we can state that the energy of the translational motion of the molecule of mass m and a velocity v in the given direction is $\frac{1}{2}mv^2$. We can see a similar structure in case of the rotational energy; the momentum of inertia I replaces the mass, the angular velocity ω replaces the translational velocity, and the energy of rotation per degree of freedom is $\frac{1}{2}I\omega^2$. In the expression for the vibrational energy of 1 degree of freedom, there are *two quadratic terms*; $\frac{1}{2}mv^2$ describes the kinetic energy and $\frac{1}{2}kx^2$ describes the potential energy. The sum of these two terms is the total energy of vibration. In the light of these observations, we can generalize that for all (classical mechanical) quadratic terms, the expectation value of molecular energy is $\frac{1}{2}kT$, at least at high enough temperature. This is called the *equipartition theorem*.

An interesting consequence of this theorem is the expression for the heat capacity, which is the derivative of the expectation of energy with respect to temperature:

$$\frac{\partial M(E)}{\partial T} = C_V. \quad (10.117)$$

Writing this derivative for the sum of the energy terms shown in the table, relative to 1 mol, we get:

$$c_V = \frac{1}{2}R(3 + \nu_R + 2\nu_V). \quad (10.118)$$

According to this result, we can have information concerning the structure of the molecules from the molar heat capacity. If the molar heat capacity is $3/2 RT$, the particles of the gas have only translational degrees of freedom, thus they are

monatomic molecules. If $c_V = 5/2 RT$, molecules have a linear structure, and vibrations do not play any role in the heat capacity. If c_V is greater than $5/2 RT$, vibrational modes also contribute to the heat capacity. The greater the molar heat capacity with respect to $5/2 RT$, the more the number of vibrational degrees of freedom can be. Prior to the development of infrared and Raman spectroscopy – which enable to identify vibrational modes of molecules, heat capacity measurements often helped to determine the structure of molecules.

10.3 General Statistical Definition and Interpretation of Entropy

Based on the expressions for the entropy on a microcanonical and a canonical ensemble, we might think that the interpretation and derivation of entropy is different on these two ensembles. However, it can be shown that entropy can be derived quite generally as a well-determined expectation value for any distribution according to the following expression:

$$S = -kM(\ln p_i) = -k \sum_{\forall i} p_i \ln p_i. \quad (10.119)$$

Obviously, entropy is the negative of the expectation of the logarithm of the probability density function multiplied by a constant. (The constant k only defines the scale of entropy.) The definition could have been written for a continuous distribution as well – by changing summation for integration – but the states in statistical thermodynamics are always discrete, in accordance with quantum mechanics, thus it is enough to deal with the formula of (10.119).

Let us first see whether the microcanonical entropy can be calculated this way, by substituting the probability density function $p_i = 1/\Omega$ into (10.119):

$$-k \sum_{i=1}^{\Omega} p_i \ln p_i = -k \sum_{i=1}^{\Omega} \frac{1}{\Omega} \ln \frac{1}{\Omega} = -k \frac{1}{\Omega} \sum_{i=1}^{\Omega} -\ln \Omega = k \frac{1}{\Omega} \cdot \Omega \ln \Omega = k \ln \Omega. \quad (10.120)$$

This result is in fact identical to the entropy calculated in (10.5).

Let us make the calculation using this time the canonical probability density function $p_i = \frac{1}{Q} e^{-\beta E_i}$:

$$-k \sum p_i \left[\ln \frac{1}{Q} - \beta E_i \right] = k \sum p_i \ln Q + k \sum p_i \beta E_i = k \ln Q + k \beta \sum \frac{E_i e^{-\beta E_i}}{Q}. \quad (10.121)$$

To calculate the result, we have made use of the fact that $\ln Q$ is not a random variable (it does not depend on the index i), thus its expectation value is itself. As to the second term, we have substituted β , which can be factored out from the summation. The first term thus yields the Massieu function $J = -F/T$, while the second term is the internal energy U (the expectation of E_i) divided by the temperature T :

$$k \ln Q + k \frac{1}{kT} \sum E_i \frac{e^{-\beta E_i}}{Q} = -\frac{F}{T} + \frac{U}{T}. \quad (10.122)$$

From the known relation $F = U - TS$, it is clear that the result is the entropy again.

We can frequently encounter the common statement that “entropy is the measure of disorder”. As a matter of fact, we do not need this “explanation”. We know entropy very well and can also calculate it from the postulates of (macroscopic) thermodynamics, from the results obtained in statistical thermodynamics, and in a general way, from the above definition of (10.119). Thus, entropy is a uniquely determined quantity. Let us examine, in what sense we can call it the “measure of disorder”. It should be stated that – contrary to the quantitative definition of entropy – the concept “order” and “disorder” cannot be defined quantitatively, except for the regular lattice of crystals. Order and disorder in general are categories rather based on subjective judgment, thus cannot be quantified in a unique way.

Let us first consider those properties of entropy that are in accordance with the generally acceptable notion of the “measure of disorder”. If the value of one of the discrete probabilities p_i in the distribution function is 1 (consequently, all the others are zero), then

$$S = -k \ln 1 = 0; \quad (10.123)$$

That is, the measure of disorder is zero if the (thermodynamic) system can only exist in one single microstate. Similarly, the mathematical theorem that the entropy is maximal for a uniform distribution is also in agreement of the intuitive concept of disorder. In this case, neither of the states is preferred, thus there is equal chance to find any of them, which is equivalent to a complete disorder. The third property supporting the analogy is that the disorder monotonously increases if the number of possibilities (states) is increased provided their distribution is uniform. Entropy always increases (being an extensive property) when the size of the system is increased. To keep the analogy, we should accept that the disorder of particles is greater if they can move in a greater space.

However, the analogy between the (nonquantitative) disorder and the (exact) entropy cannot be carried any further. To illustrate this, we shall mention a few contraindications as well. Let us examine Fig. 10.7 and tell which of the two states of the depicted containers is more ordered. Most of the spectators – if not all of them – would say that the left-hand side container – the one before mixing – is less

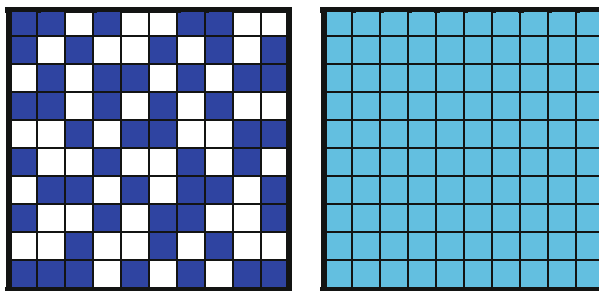

Fig. 10.7 *Left panel:* a container divided by a grid of plates into 10×10 compartments. Half of the compartments is chosen randomly and filled with aqueous copper sulfate solution, the other half with pure water. *Right panel:* the same container with raised grid of plates and completely mixed content

ordered than the right-hand side one. This opinion is really appropriate, as on a regular lattice, order can be measured by the regularity of occupation of positions. However, we know very well that the entropy in the right-hand container – after mixing – is greater. First, mixing is a spontaneous process, which is accompanied by an increase of entropy (in an isolated system). Second, we can readily calculate the increase of entropy by applying (6.42). Thus, we can conclude from this example that *entropy does not measure disorder*.

A similar example could be when filling in two liquids of different temperatures (say, the colder of temperature T_1 in place of the colored solutions, and the hotter of temperature T_2 in place of the water). In case of diathermal plates, the same temperature T_3 ($T_1 < T_3 < T_2$) would settle in each compartment after a while. Thus, from a more disordered initial state, a less disordered final state would be formed in a spontaneous process, while the entropy would increase. In this case, we could calculate the increase in entropy by applying (4.42).

As a third example, we can mention a supercooled liquid. Suppose we carefully cool a sample of highly purified water to -10°C without freezing, which is the initial state. After nucleation of the supercooled water with a tiny quantity of ice crystals, part of the water will freeze immediately – and spontaneously. We can state that part of the “disordered” liquid has been transformed into “ordered” crystals, thus the disorder decreased. Again, we know that this process was also spontaneous, thus the entropy increased in the isolated system – despite an increase in order. Knowing the molar heat capacities of liquid water and water ice, we can again calculate the increase of entropy. (The partial condensation of supersaturated vapor is another example.)

On the basis of the above examples, we can conclude that it is not worth considering entropy as the measure of disorder, as we can easily be mistaken taking the analogy seriously. If we want to find an analogy, the “spread” of the given distribution is a better choice. This spread is properly measured by the expression of (10.119), which is maximal if the distribution is uniform, and it decreases as we concentrate the distribution around one or several peaks.

Let us finally examine an interesting property of entropy already mentioned at the end of Sect. 2.2.1. According to Postulate 4, the entropy of any system is zero at $T = 0$ K. However, this is not always fulfilled, due to practical reasons. Quantum mechanics prescribes no degeneration at the temperature $T = 0$ K; thus, any macroscopic system should have a single possible state at this temperature. We know that at 0 K, translational and rotational motions of molecules cease to exist, their vibrational and electronic modes are in their ground state. Consequently, all contributions to the molecular partition function have the value $q = 1$, thus their product is also 1, and the N th powers are also 1. As a result, the logarithm of Q is zero, thus the entropy is also zero.

At temperature $T = 0$ K, materials are crystalline. They also have only one single stable state at zero temperature, which also leads to zero entropy. However, this unique state at zero temperature is not always possible. If the energy of molecules at the freezing point during cooling is enough that the arrangement of the crystal can be different from that of the most stable state, this arrangement can be frozen. It means that the energy of the molecules in the crystal upon further cooling is not sufficient to change this nonequilibrium state and rearrange to a perfect crystal. Thus, the “frozen” imperfect crystal can survive for an infinitely long time and the number of possible microstates will be greater than 1 even if the temperature is arbitrarily close to zero. Accordingly, the entropy will be also greater than zero. This is called the *residual entropy*. However, such systems are *not equilibrium systems*, thus they do not question the validity of Postulate 4.

10.4 Calculation of the Chemical Equilibrium Constant from Canonical Partition Functions

To calculate the equilibrium constant, let us first express the free energy F of pure gases with the help of the total molecular partition function q :

$$F = F(0) - kT \ln Q = F(0) - kT \ln \frac{q^N}{N!}. \quad (10.124)$$

The term $F(0)$ is needed to adjust the zero level of free energy, taking into account the arbitrarily chosen zero levels when calculating contributions to the molecular partition function q .

Let us apply the Stirling formula to approximate the factorial in the above expression:

$$F = F(0) - NkT \ln q + kT(N \ln N - N) = F(0) - kT \ln q + kTN(\ln N - 1). \quad (10.125)$$

Let us substitute $R = N_A kT$ in place of NkT , thus we obtain – after some rearrangement – the following expression for the *molar* free energy:

$$F_m = F_m(0) - RT \ln \frac{q}{N_A} - RT. \quad (10.126)$$

The equilibrium constant at constant pressure and constant volume can be obtained from the reaction standard Gibbs potential $\Delta_r G^\ominus$; thus, we should calculate this quantity from F_m . Using the definition $G_m = F_m + PV_m$ and restricting the calculations for ideal gases, we can write PV_m in place of RT , thus obtaining the simple expression:

$$G_m = F_m(0) - RT \ln \frac{q}{N_A}. \quad (10.127)$$

As we are interested in the standard molar Gibbs potential, we have to calculate the partition function q at the standard pressure P^\ominus . Accordingly, it is the partition function in a canonical ensemble having N_A particles at temperature T , in a volume $V^\ominus = RT/P^\ominus$. Let us denote this molecular partition function by q^\ominus , and calculate the standard molar Gibbs potential as:

$$G^\ominus = F_m(0) - RT \ln \frac{q^\ominus}{N_A}. \quad (10.128)$$

We can express $F_m(0)$ based on the definition $F = U - TS$ as:

$$F_m(0) = U_m(0) - T(0)S(0). \quad (10.129)$$

By choosing $T(0) = 0$ K as the reference temperature, the term $T(0)S(0)$ vanishes, thus we can replace $F_m(0)$ by $U_m(0)$.

Now we are in a position to write the standard Gibbs potential of the general reaction $\sum_{i=1}^r \nu_i A_i = 0$ in the following form:

$$\Delta_r G^\ominus = \Delta_r U_m(0) - RT \sum_{i=1}^r \ln \left(\frac{q_i^\ominus}{N_A} \right)^{\nu_i} = \Delta_r U_m(0) - RT \ln \prod_{i=1}^r \left(\frac{q_i^\ominus}{N_A} \right)^{\nu_i}. \quad (10.130)$$

Making use of the relation $\Delta_r G^\ominus = -RT \ln K$, it is easy to express the equilibrium constant K . To simplify the notation, let us write $\Delta_r U_0$ in place of $\Delta_r U_m(0)$. Thus, we obtain:

$$K = \prod_{i=1}^r \left(\frac{q_i^\ominus}{N_A} \right)^{\nu_i} \cdot e^{-\frac{\Delta_r U_0}{RT}}. \quad (10.131)$$

Obviously, all we need to calculate the equilibrium constant (for ideal gas reactions) are the standard molecular partition functions of the reactive species and their zero point energies.

The above expression has a general validity if we replace the ratio q_i^\ominus/N_A by the molar partition function Q_i^\ominus calculated correctly for the given species (i.e., not using the ideal gas approximation).

$$K = \prod_{i=1}^r (Q_i^\ominus)^{v_i} \cdot e^{-\frac{\Delta_r U_0}{RT}}. \quad (10.132)$$

The meaning of $\Delta_r U_0$ is the same; it is the zero-point energy of the reaction. A convenient way of calculating the molar partition functions Q_i^\ominus for interacting molecules is to derive them from molecular dynamic simulations.

Equations (10.131) and (10.132) have paramount importance in chemistry. For not too large molecules, the molecular energy can be obtained by quantum chemical methods for all molecular modes, from which the partition function can be calculated. For larger molecules, we can obtain the molecular energies from spectroscopic data. An unknown equilibrium constant can also be calculated based on the knowledge of reactants of similar chemical structure. In this case, the partition function should be decomposed into the product of nonvariable and variable factors, and the calculation of the variable factors is enough to calculate the unknown equilibrium constant. Equation (10.131) has a great importance also in reaction kinetics; transition-state theory is also based on this relation.

Due to this crucial role in chemistry, we will show the statistical thermodynamical expression of two actual reactions. The first example is a *bimolecular* reaction (with a single product)



whose equilibrium constant can be written as:

$$K = \frac{N_A q_C^\ominus}{q_A^\ominus q_B^\ominus} e^{-\frac{\Delta_r U_0}{RT}}. \quad (10.134)$$

The second one is a *unimolecular* reaction (with a single product)



whose equilibrium constant can be written as:

$$K = \frac{q_B^\ominus}{q_A^\ominus} e^{-\frac{\Delta_r U_0}{RT}}. \quad (10.136)$$

As we can see, if the sum of the exponents in the denominator and the numerator is the same, the Avogadro constant N_A does not figure in the formulae.

Problems

1. Express the molar heat capacity of an Einstein solid as a function of temperature. Calculate the $T \rightarrow 0$ and $T \rightarrow \infty$ limits. Draw a plot of the molar heat capacity as a function of temperature between 0 K and 10 K (use the reference value of $u_0 = 100$ J).

Solution: Let us start from the molar entropy (10.13) of the crystal:

$$s = 3R \ln\left(1 + \frac{u}{u_0}\right) + 3R \frac{u}{u_0} \ln\left(1 + \frac{u_0}{u}\right).$$

We can calculate the temperature as

$$T = \left(\frac{\partial s}{\partial u}\right)^{-1} = \frac{u_0}{3R \ln \frac{u+u_0}{u}}.$$

Solving the above expression for u yields the molar internal energy:

$$u = \frac{u_0}{e^{\frac{u_0}{3RT}} - 1}.$$

Derivation of this function with respect to temperature directly gives the molar heat capacity:

$$c_V = \frac{\partial u}{\partial T} = \frac{u_0^2 e^{\frac{u_0}{3RT}}}{3RT^2 \left(e^{\frac{u_0}{3RT}} - 1\right)}.$$

The limits are in accordance with experimental data; the $T \rightarrow 0$ limit is zero, the $T \rightarrow \infty$ limit is $3R$ (complying with the *Dulong–Petit* rule). The plot of the function from 0 to 10 K is the one below. (Note that the exponential rise is not in accordance with experimental data.)

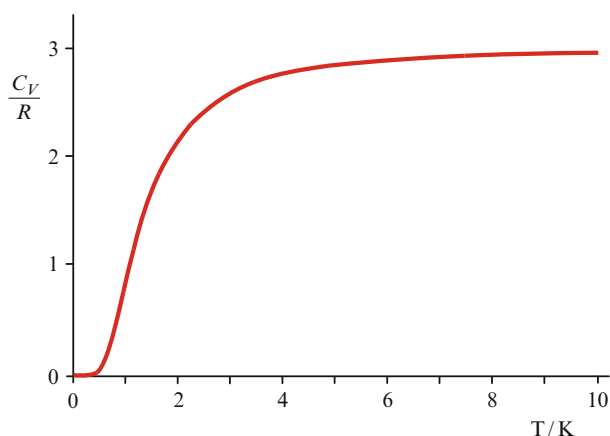

2. Calculate the equilibrium constant of the reaction

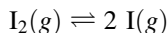

at 800 K and 1 atm, supposing each component as an ideal gas, based on the following data:

$$\tilde{\nu} = 214.6 \text{ cm}^{-1}; \quad B = 214.6 \text{ cm}^{-1}; \quad E_d = 1.5422 \text{ eV}.$$

Here, $\tilde{\nu}$ is the wave number of the vibration, B is the rotational constant, and E_d is the dissociation energy (also at 0 K) of the I_2 molecule. At the given temperature, the molecule is in its nondegenerate ground state, while the iodine atom is in a degenerate electronic state having a multiplicity of 4.

Solution: We can compute the equilibrium constant K by means of the formula

$$K = \frac{(q_{\text{I}}^{\ominus})^2}{N_{\text{A}} q_{\text{I}_2}^{\ominus}} e^{-\frac{E_d}{RT}}.$$

To compute the standard molecular partition function of the iodine atom, we only have to calculate its translational and electronic contributions, as there are no rotational or vibrational states. The electronic contribution is the number of degeneracy; $q_{\text{I,el}}^{\ominus} = 4$. The translational contribution can be calculated using (10.67), in which m is the mass of an iodine atom:

$$m = \frac{M_{\text{I}}}{N_{\text{A}}} = \frac{126.90447 \text{ gmol}^{-1}}{6.0220 \times 10^{23} \text{ mol}^{-1}} = 2.10734 \times 10^{-25} \text{ kg},$$

and the ideal gas molar volume V can be obtained by using the equation of state of the ideal gas:

$$V = \frac{RT}{P} = \frac{8.314 \text{ Jmol}^{-1}\text{K}^{-1} \cdot 800 \text{ K}}{101325 \text{ Pa}} = 0.06564 \text{ m}^3/\text{mol}.$$

Thus,

$$\begin{aligned} q_{\text{I,trans}}^{\ominus} &= \left(\frac{2\pi mkT}{h^2} \right)^{3/2} \cdot V \\ &= \left(\frac{2\pi \cdot 2.10734 \times 10^{-25} \text{ kg} \cdot 1.3807 \times 10^{-23} \text{ JK}^{-1} \cdot 800 \text{ K}}{(6.626 \times 10^{-34} \text{ Js})^2} \right)^{3/2} \times 0.06564 \text{ m}^3. \end{aligned}$$

The result is $q_{\text{I,trans}}^{\ominus} = 3.992 \times 10^{32}$, which multiplied by the electronic contribution gives $q_{\text{I}}^{\ominus} = 1.597 \times 10^{33}$.

To compute the standard molecular partition function of the I_2 molecule, we have to calculate all four contributions. The electronic contribution is simple, as there is only a single electronic state available; thus, $q_{I_2,el}^\ominus = 1$. The translational contribution can be calculated similarly to the case of the iodine atom; the only difference is the molar mass, which is twice that of the atom. The result of the calculation is accordingly $2^{3/2}$ times that of $q_{I,trans}^\ominus$; that is, $q_{I_2,trans}^\ominus = 1.129 \times 10^{34}$. The rotational contribution can be calculated using (10.85), but with a division by 2, as the I_2 molecule is a *homonuclear* rotor, with a rotational symmetry factor of $\sigma = 2$:

$$q_{I_2,rot}^\ominus = \frac{kT}{2hcB}.$$

When substituting the actual values, we should be careful with units. The rotational constant B is measured in cm^{-1} units, which should be multiplied by hc to yield energy. Thus, either hcB should be given in SI energy units, or kT should be given in cm^{-1} units. Choosing the latter, we can express the Boltzmann constant as $0.69503 \text{ cm}^{-1}/\text{K}$.¹⁰ (As a matter of fact, a division by hc is also included.) The resulting rotational partition function is $q_{I_2,rot}^\ominus = 7454.1$.

The vibrational contribution can be calculated using (10.90). Again, we should be careful using units. The energy of the vibration is given as the wavenumber in cm^{-1} units, thus we can use again the Boltzmann constant given above as $k = 0.69503 \text{ cm}^{-1}/\text{K}$ and consider the vibrational wavenumber as energy, instead of $h\nu$. The resulting vibrational partition function is $q_{I_2,vib}^\ominus = 3.126$.

Finally, we can multiply the four contributions to get the molecular partition function $q_{I_2}^\ominus = 2.632 \times 10^{37}$.

When calculating the equilibrium constant, we should again take into account the units of energy. As the zero-point reaction energy is given in eV units, it is useful to use the according units of the gas constant, which is then given as $R = 5.189 \times 10^{19} \text{ eV K}^{-1} \text{ mol}^{-1}$. The resulting equilibrium constant is 3.104×10^{-5} .

¹⁰The reason behind the practice to use cm^{-1} as an energy unit is historical. The quantum mechanical expression for the energy of a photon is $E = h\nu$, where h is the Planck constant and ν is the frequency of the photon. The frequency can be expressed with the wavelength of the photon λ and the velocity of light in vacuum c as $\nu = c/\lambda$, while the *wavenumber* $\tilde{\nu}$ as $\tilde{\nu} = 1/\lambda$. Thus, the energy expressed as a function of the wavenumber is $E = hc\tilde{\nu}$. At the beginning of the twentieth century when quantum mechanics and spectroscopy were developing, the Planck constant was not known precisely, but wavenumbers could be measured quite precisely. This resulted in measuring optical spectroscopic energies as wavenumbers in cm^{-1} unit, which remains in use ever since. However, we should keep in mind that the energy dimension is $hc\tilde{\nu} = 1.9865 \times 10^{-23} \text{ Jcm} \times \tilde{\nu}$.

Further Reading

Atkins P, de Paula J (2009) Physical chemistry, 9th edn. Oxford University Press, Oxford

Callen HB (1985) Thermodynamics and an introduction to thermostatistics, 2nd edn. Wiley, New York

Denbigh KG (1981) The principles of chemical equilibrium, 4th edn. Cambridge University Press, Cambridge

Greiner W, Neise L, Stöcker H (1994) Thermodynamics and statistical mechanics, 2nd edn. Springer, Heidelberg

Guggenheim EA (1985) Thermodynamics: an advanced treatment for chemists and physicists, 7th edn. North Holland, Amsterdam

IUPAC (2007) Quantities, units and symbols in physical chemistry, 3rd edn. RSC, Cambridge

Maczek A (1998) Statistical thermodynamics. Oxford University Press, Oxford, reprinted 2002

Silbey LJ, Alberty RA, Moungi GB (2004) Physical chemistry, 4th edn. Wiley, New York

Chapter 11

Toward Equilibrium: Elements of Transport Phenomena

When discussing the conditions of thermal equilibrium in Chap. 3, we have stated that, during a process toward the equilibrium state, thermal energy flows from the higher temperature subsystem to the lower temperature subsystem until the two temperatures become equal. We have similarly stated that chemical components are transported from the higher chemical potential region to the lower chemical potential region until equilibrium is achieved, when chemical potentials of freely moving species are identical everywhere in the system. The same principle also applies for systems where the electric potential is not the same in two regions; if there is a free passage of charge carriers within these regions, positive charge is transported to the lower electric potential region. (The opposite direction transport of negative charges is equivalent to this change.) We can conclude that a difference in an intensive property results in a transport of the related extensive property.

The general statement of this principle is also valid for a continuous (spatial) change of the intensive property. In this case, the spatial transport of an extensive property is induced by the *gradient* of the related intensive property. If there is a continuous change of the intensive property within a system, there is no equilibrium; thus, intensive variables are not well defined.¹ However, if the gradient (the inhomogeneity of the system) is not too large, the system remains close to equilibrium, and we can consider a *local equilibrium* in small but finite volume elements ΔV . This volume element is small enough that we can suppose that there is equilibrium within the small volume, but there are many molecules within, so that we can consider it as a small macroscopic volume. In that case, transport of extensive properties can be described using *linear transport equations*.

These equations are based on the experimental evidence that the flux of the extensive property resulting from a gradient of the related intensive property is *proportional* to this gradient. The gradient is called a *general force* driving the transport. It is a vector whose components are the partial derivatives of the intensive

¹There is an exception from this rule; in a potential field, there might be a continuous change in the equilibrium of an extensive property. A well-known example is the change of pressure of the air with altitude. In this case, an inhomogeneous system is in equilibrium in the potential field.

variable with respect to the spatial coordinates. If we restrict the discussion in only one dimension (say, z), then the gradient is simply a derivative:

$$\text{grad } \psi = \frac{d\psi}{dz}. \quad (11.1)$$

The flux of an extensive property X (the *general flux*) is defined as follows:

$$J(X) = \lim_{\Delta A \rightarrow 0} \frac{1}{\Delta A} \frac{dX}{dt}. \quad (11.2)$$

In this expression, the derivative dX/dt is a *current* of the quantity X , and the division by the surface ΔA (through which the current flows) transforms it into *current density* (a current relative to the surface), which is called *flux*. According to this definition, the flux can also be formulated as a second partial derivative of the function $X(\mathbf{r}, t)$:

$$J(X) = \frac{\partial^2 X(\mathbf{r}, t)}{\partial t \partial \sigma}. \quad (11.3)$$

Here, \mathbf{r} is the position vector and t is time, while $\partial \sigma$ is an infinitesimal surface element perpendicular to the direction of the flow. Consequently, the flux of a scalar quantity X is a vector. As it is much simpler to write one-dimensional equations than three-dimensional ones, we shall restrict ourselves in the rest of this chapter to write one-dimensional transport equations. Accordingly, we can reformulate the definition of flux in the z direction as

$$J_z(X) = \frac{\partial^2 X(z, t)}{\partial t \partial a}, \quad (11.4)$$

where $X(z, t)$ is the extensive quantity X as a function of the z coordinate and the time t , while a is an infinitesimal surface element perpendicular to the z direction.

We also restrict the discussion to *conductive transport*, excluding hydrodynamic and convective flow (the displacement of the bulk medium having the property X) as well as radiative transfer (the energy transfer in the form of electromagnetic radiation).

According to the above statements and definitions, if the condition of local equilibrium applies (the entire system is close to equilibrium), conductive transport can be described by linear transport equations, which can be written in one dimension as follows:

$$J_z(X) = \alpha \frac{d\psi}{dz}. \quad (11.5)$$

Here, $J_z(X)$ is the flux of the extensive quantity X in the z direction, $d\psi/dz$ is the gradient of the associated intensive quantity ψ , which drives the transport, and α is

the *coefficient of conductivity*. In the rest of this chapter, we shall briefly describe the concrete form of the linear transport equation for heat conduction, electric conduction, and viscous flow. Diffusion – the conductive transport of chemical species – will be treated in somewhat more detail as it has a great importance in chemical practice.

11.1 Transport Equations for Heat, Electricity, and Momentum

If energy is transferred due to a temperature gradient, it is called the *conduction of heat*, which can be described by the following equation:

$$J_z(\text{energy}) = -\lambda \frac{dT}{dz}. \quad (11.6)$$

This equation is called *Fourier's law*,² where J_z is the flux of energy in the z direction, dT/dz is the temperature gradient, and λ is the *coefficient of thermal conductivity*. The minus sign indicates that a positive gradient (increasing temperature along the positive z direction) drives an energy transport in the negative z direction, which means that heat is flowing from the higher to the lower temperature region. The SI unit of the heat flux is $\text{J m}^{-2} \text{s}^{-1}$ and that of the temperature gradient is K m^{-1} ; thus, the unit of the coefficient of thermal conductivity is $\text{J K}^{-1} \text{m}^{-1} \text{s}^{-1}$, which is equivalent to $\text{W K}^{-1} \text{m}^{-1}$.

If electric charge is transferred in an electric conductor due to a potential gradient, it is called *electric conduction*, which can be described by the equation:

$$J_z(\text{electric charge}) = -\kappa \frac{d\varphi}{dz}. \quad (11.7)$$

The equation is called *Ohm's law*,³ where J_z is the electric current density in the z direction, $d\varphi/dz$ is the electric potential gradient, and κ is the *electric conductivity*. The minus sign indicates again that a positive potential gradient drives the (positive) charge transport in the negative z direction; i.e., electric current is flowing from the higher to the lower potential range. The SI unit of the electric current density is $\text{C m}^{-2} \text{s}^{-1}$ and that of the potential gradient is V m^{-1} ; thus, the unit of the electric conductivity is $\text{C s}^{-1} \text{V}^{-1} \text{m}^{-1}$ (which is equivalent to $\text{A V}^{-1} \text{m}^{-1}$) or S m^{-1} . (S is called Siemens and is equivalent to VA^{-1} .)

²Jean Baptiste Joseph Fourier (1768–1830) was a French mathematician and physicist best known for the investigation of convergent trigonometric series (later called Fourier series) and their applications to problems of heat transfer.

³Georg Simon Ohm (1789–1854) was a German physicist. Using electrochemical cells (voltaic piles), he determined that the electric current driven by a potential difference across a conductor is proportional to the potential difference.

Equation (11.6) is a general equation for electric conductance. A special form is the version of Ohm's law, which is usually found in elementary textbooks, and refers to the absolute value of the current I , instead of the current density J . Accordingly, the equation can be written as $I = U/R$, where U is the potential difference between the end points of a conductor and R is the *resistance* of the conductor, the inverse of conductivity. In solution electrochemistry, there are also special expressions for the current density, which take into account the concentration of charge carrier species as well.

Viscous flow is a special kind of transport. There is a momentum transfer between layers of a liquid in case of hydrodynamic flow, i.e., during the relative displacement of adjacent layers. The related transport phenomenon can be illustrated in Fig. 11.1.

In case of a laminar flow (i.e., without turbulences), the velocity profile within a tube (dashed lines) has a parabolic shape. This means that the velocity of the flowing liquid is zero at exactly the boundary of the tube, and it is maximal in exactly the center; it diminishes continuously in between according to the second power of the distance from the center along the z coordinate. During the flow, layers of different velocity exercise friction on each other. As a consequence, momentum of the x direction is transferred perpendicularly to the direction of the momentum and velocity, i.e., in the z direction. The equation describing momentum transfer has also the form of (11.5):

$$J_z(\text{momentum along the } x \text{ axis}) = -\eta \frac{dv_x}{dz}. \quad (11.8)$$

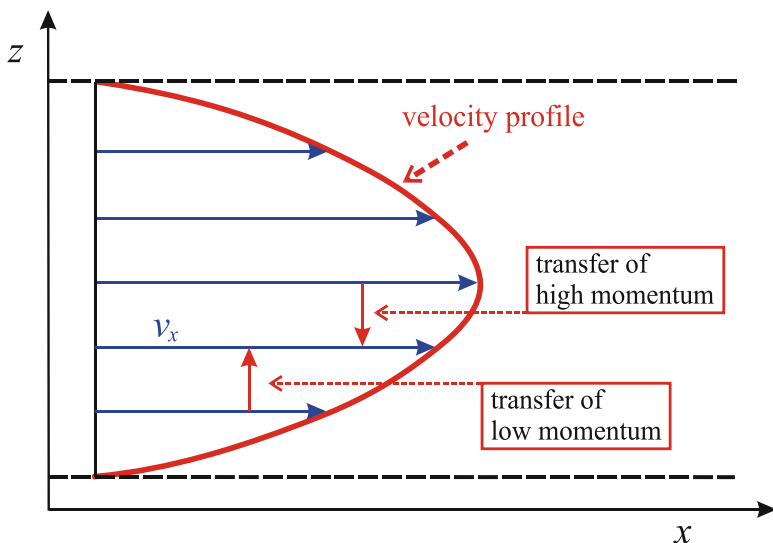

Fig. 11.1 Velocity profile of a laminar flow in a section of a tube. The profile is of parabolic shape shown as a thick continuous curve. *Arrows* pointing to the positive x direction indicate velocity vectors v_x . *Arrows* pointing to the positive and negative z directions indicate fluxes of the higher and the lower momentum J_z , respectively

The equation is called *Newton's law*,⁴ where J_z is the flux of the x -direction momentum along the z direction, dv_x/dz is the x -direction velocity gradient along the z direction, and η is called the *viscosity*.⁵ The minus sign indicates again that a positive velocity gradient drives the (higher) momentum transport in the negative z direction, i.e., toward slower layers (and vice versa). The SI unit of the momentum flux is $(\text{kg m s}^{-1}\text{m}^{-2}\text{s}^{-1})$ and that of the velocity gradient is $(\text{m s}^{-1}\text{m}^{-1})$; thus, the unit of viscosity is $\text{kg m}^{-1}\text{s}^{-1}$, which is equivalent to N s m^{-2} . However, as the viscosity of not too much viscous liquids (e.g., water) is much less than this unit – it is of the order of $0.001\text{ kg m}^{-1}\text{s}^{-1}$ – an alternative, traditional unit is used, named after Poiseuille.⁶ This unit is $1\text{ Poise} = 0.1\text{ kg m}^{-1}\text{s}^{-1}$, but the common unit used is one hundredth of a Poise, i.e., $1\text{ cP} = 0.001\text{ kg m}^{-1}\text{s}^{-1}$.

Another interesting property of the viscous flow is that the momentum transferred is a vector and not a scalar. If we restrict the description of the transport in one dimension, there are no complications concerning the transport equation. However, in two or three dimensions, the transport equation should be formulated according to the vector nature of the momentum.

11.2 Equations for the Diffusive Material Transport

Diffusive material transport or simply *diffusion* is the transport of chemical species induced by a concentration gradient. If the transport is only due to diffusion, the medium (or solvent) is not moving and only molecules of the species migrate whose concentration gradient is nonzero. As this kind of material transport has a great importance in chemical practice, we shall deal in more detail with it. We shall not only write the general transport equation (11.5) for this particular case, but also derive the equation for the temporal change of concentration of the diffusing species. Let us start by formulating the transport equation similar to the previous cases for this kind of transport.

⁴The famous English physicist Isaac Newton (1643–1727) also dealt with fluid mechanics. By describing hydrodynamic flow, he used the equivalent of the equation later named after him. The fluid obeying this law is called a *Newtonian fluid*.

⁵The word comes from the Latin expression *viscum* for birdlime (the glutinous material spread on twigs to catch birds). *Viscum* meant originally the parasitic plant mistletoe whose scientific name is still *viscum album*. A low value of viscosity means an easily flowing liquid, while a high viscosity liquid (e.g., honey) is “sticky” and does not flow easily.

⁶Jean Louis Marie Poiseuille (1797–1869) was a French physician and physiologist. He was well trained in physics and mathematics, and he derived an equation for the blood flow in capillaries and veins, in the form of a laminar flow of a Newtonian fluid through a cylindrical tube with constant circular cross section. This is the equation of nonturbulent flow of liquids through pipes, nowadays called as the Hagen–Poiseuille equation.

11.2.1 Fick's First Law: The Flux of Diffusion

The diffusive flux of a chemical species i driven by a concentration gradient can also be described by the general transport equation (11.5) as follows:

$$J_z(n_i) = -D_i \frac{dc_i}{dz}. \quad (11.9)$$

This equation is called *Fick's first law*,⁷ where $J_z(n_i)$ is the material flux of the species i in the z direction, dc_i/dz is the concentration gradient of the same species, and D_i is its *diffusion coefficient*. The minus sign indicates again that a positive gradient (increasing concentration along the positive z direction) drives the material transport in the negative z direction, which means that molecules are moving from the higher to the lower concentration region. The SI unit of the material flux is $\text{mol m}^{-2} \text{s}^{-1}$ and that of the concentration gradient is $\text{mol m}^{-3} \text{m}^{-1}$; thus, the unit of the diffusion coefficient is $\text{m}^2 \text{s}^{-1}$.

It should be mentioned that the intensive property related to the amount of a chemical species is *not* concentration but *the chemical potential* of this species. Thus, the driving force of diffusion is, strictly speaking, not the concentration gradient but the gradient of the chemical potential. However, if the gradients are not too high, the gradient of the chemical potential is approximately proportional to the gradient of concentration. Nevertheless, in a large concentration region, the diffusion coefficient D_i also depends on the concentration of the diffusing species.

11.2.2 Fick's Second Law: The Rate of Change of the Concentration Profile

All the transport phenomena discussed in this chapter concern the transport of extensive quantities that are conserved. There is a conservation principle valid for energy, electric charge, momentum, and matter. This conservation law can be formulated as an equation called *material balance equation* or *continuity equation*. We shall discuss this principle and the corresponding equation on the example of diffusion.

The total amount of the conserved quantity (in this case, the amount of the species i) inside any region can only change by the amount that passes in or out of the region through the boundaries. (While discussing diffusion, we exclude chemical reactions that would produce or consume chemical species.) Using this principle, we can calculate how concentration changes with time during diffusion. When calculating the material balance, we shall drop the subscript i referring to the actual

⁷Adolf Eugen Fick (1829–1901) was a German physiologist. In 1855, he published the quantitative description of diffusion, based on experiments where salts diffused in a tube between two reservoirs.

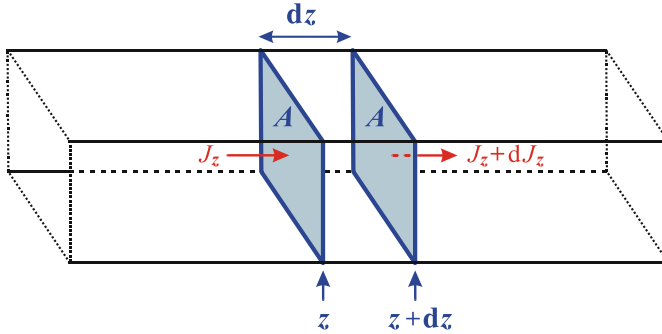

Fig. 11.2 A small element of the system where diffusion takes place in the positive z direction. Two surface elements perpendicular to the direction of the diffusion are shown, each having a finite surface A . The (infinitesimal) distance between the two surface elements is dz . The diffusive flux entering the layer between the two surface elements at the coordinate z is J_z , while the one leaving this layer at the coordinate $z + dz$ is $J_z + dJ_z$.

species. We shall start with Fick's first law and construct the material balance equation using the notation of Fig. 11.2.

The volume within the two surface elements (which we shall call as a *cell*) is Adz . Let us denote the concentration within the (infinitesimally thin) cell by c . We would like to have an expression first for the change of this concentration due to the diffusion flux entering the cell. On the basis of (11.9), the rate of *change of the amount* of diffusing species inside the cell due to the entering flux is

$$\left(\frac{dn}{dt}\right)_{in} = J_z A. \quad (11.10)$$

To get the rate of *concentration change*, we should divide this expression by the volume Adz :

$$\left(\frac{dc}{dt}\right)_{in} = \frac{J_z A}{Adz} = \frac{J_z}{dz}. \quad (11.11)$$

In a similar manner, we can calculate the rate of concentration change within the cell due to the diffusion flux leaving the cell:

$$\left(\frac{dc}{dt}\right)_{out} = \frac{-(J_z + dJ_z)A}{Adz} = -\frac{(J_z + dJ_z)}{dz}. \quad (11.12)$$

Using the above results, we can write the material balance equation taking into account that the only change in concentration is due to the entering and leaving diffusion flux:

$$\left(\frac{dc}{dt}\right) = \left(\frac{dc}{dt}\right)_{in} - \left(\frac{dc}{dt}\right)_{out} = -\frac{J_z - (J_z + dJ_z)}{dz} = -\frac{dJ_z}{dz}. \quad (11.13)$$

We can now resubstitute dJ_z from Fick's first law:

$$-\frac{dJ_z}{dz} = -\left[\frac{d}{dz}J_z\right] = -\left[\frac{d}{dz}\left(-D\frac{\partial c}{\partial z}\right)\right] = D\left(\frac{\partial^2 c}{\partial z^2}\right). \quad (11.14)$$

By comparing the two equations, we can write the rate of change of the concentration due to diffusion in case of a concentration gradient in the usual form:

$$\left(\frac{\partial c}{\partial t}\right) = D\left(\frac{\partial^2 c}{\partial z^2}\right). \quad (11.15)$$

This equation is called *Fick's second law* – we should add – in one dimension. It is interesting to interpret the meaning of this result. The second derivative of the concentration function on the right-hand side is the *curvature* of the concentration profile along the z direction. Thus, the equation tells us that the rate of the change of the concentration profile at a point is proportional to the curvature of the profile at this point, and the proportionality constant is the same diffusion coefficient as in Fick's first law. This also means that an infinitely large curvature (e.g., in case of two homogeneous solutions of different concentrations having put in contact instantaneously) leads to an infinitely large diffusion rate, which immediately “smoothens” the discontinuity of the concentration profile, slowing down the diffusion rate to a finite value. The further the diffusion continues, the slower it becomes. Another interesting feature of Fick's second law is the case of a linear concentration profile. If such a profile is present in a solution, the rate of change of this profile is zero, as its curvature is also zero. (The reason behind is that the entering and the leaving diffusion flow at the boundaries of the thin cell discussed above are the same, as the driving gradient is also the same.)

Equation (11.15) is a partial differential equation, which we should solve in order to calculate the time-dependent concentration profile. By observing the equation, we can see that it is *first order* with respect to time, and *second order* with respect to space, concerning the derivatives. Accordingly, to get a particular solution, we have to specify one temporal (or initial) and two spatial boundary conditions. Let us discuss a *semi-infinite diffusion*, the case of an infinite tube filled with solvent, where the solute is “smeared” uniformly at the end on the entire cross section of the tube in an infinitesimally thin layer. The initial conditions in this case can be written in the following way. At $t = 0$, n_0 moles of the substance are “smeared” uniformly at area A (the cross section of the tube) at $z = 0$ in the xy plane. For all values of z , $0 \leq c \neq \infty$, and for all values of t and z , $\int_V c \, dz \equiv n_0$ holds. (The sign \int_V means integration for the whole volume of the tube.)

The solution of the differential equation with these boundary conditions is the following function:

$$c = \frac{n_0}{A\sqrt{\pi Dt}} e^{-\frac{z^2}{4Dt}}. \quad (11.16)$$

It is worth comparing this function to a standard Gaussian of the form

$$f(x) = \frac{1}{\sqrt{2\pi\sigma^2}} e^{-\frac{x^2}{2\sigma^2}}. \quad (11.17)$$

By comparing the two functions, we can readily see that the spread σ of the concentration profile is $\sqrt{2Dt}$; thus, we can reformulate it as follows:

$$c = \frac{n_0}{A/2} \frac{1}{\sqrt{4\pi Dt}} e^{-\frac{z^2}{4Dt}}. \quad (11.18)$$

The reason behind the term $A/2$ is the semi-infinite nature of the diffusion. If the solvent can diffuse in both directions without boundaries (infinite diffusion) starting with the same initial conditions, but this time, the solvent is “smeared” in the middle of an infinite tube; the only difference in the resulting concentration profile is that A replaces $A/2$ in the denominator of the first fraction.

The two concentration profiles are illustrated in Fig. 11.3. The profiles always have a Gaussian shape, but their spread $\sqrt{2Dt}$ is time dependent. As the exponent

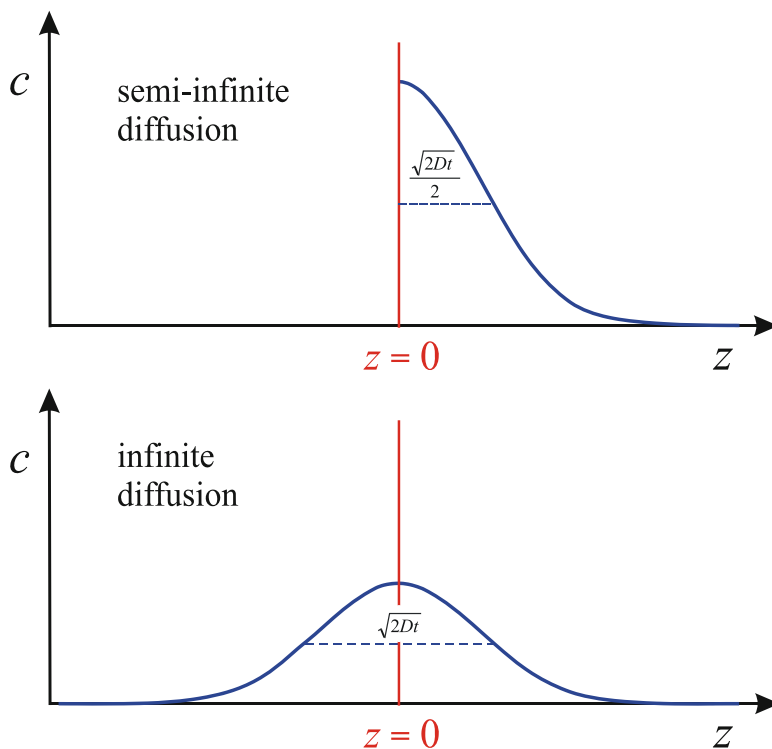

Fig. 11.3 Concentration profiles in case of a semi-infinite and an infinite one-dimensional diffusion. Note that the spreads of the functions are time dependent

should be dimensionless, it is easy to see that the dimension of Dt is length square; thus, the spread – the square root of $2Dt$ – has the dimension of length.

One-dimensional infinite diffusion has a great practical relevance in chromatographs, where diffusion takes place in a thin tube following an instantaneous injection of a small amount of solute. If the flow of the solvent is laminar, diffusion results in a spread of the injected solute during the flow as time passes.

The solution of the two- and three-dimensional infinite diffusion is also a two- and three-dimensional Gaussian. The two-dimensional case can be imagined as the diffusion in an infinitely long cylindrical tube, but with the initial condition that the solvent is concentrated at one point in the center of the cylinder. Three-dimensional infinite diffusion is very simple. It is the diffusion of a point source in a tridimensional infinite solvent. The resulting concentration profile is a tridimensional Gaussian – a function similar to the one which describes the distribution of an s electron in space, but with a time-dependent spread.

11.3 Principle Transport Processes and Coupled Processes

In the previous sections, we have discussed linear transport equations that describe the transport of an extensive quantity driven by the gradient of the related intensive quantity. Thus, thermal energy has been driven by the temperature gradient, electric charge by the electric potential gradient, and chemical species by the concentration gradient. This kind of transport is called a *principle process* driven by a *conjugate force*. However, there is also another type of transport, where the gradient of an intensive quantity also drives the transport of a different extensive quantity than the one related (or conjugate) to this particular intensive quantity. This kind of transport is referred to as a *coupled process*.

Examples of this type of process are *thermal diffusion*, when a temperature gradient drives material transport; *thermoelectric effect* when charge transfer is driven by a temperature gradient; or its inverse called *Dufour effect* when thermal energy transfer is driven by a concentration gradient (of a charge carrier).

Equations describing coupled transport processes have the same linear form if the system where it occurs can be considered being close to equilibrium in the sense mentioned at the beginning of this chapter. Thus, the same forms of linear equations of type (11.5) are also written for the flux driven, but the coefficient of conductivity is called a *coupled coefficient* in this case. The flux due to coupled processes is typically much smaller than the one due to the principle process, but in many cases, they are not negligible and quite useful.

An important example is the separation of isotopes due to thermal diffusion; the difference in their thermoelectric coefficient can lead to a difference in their flux across a temperature gradient, which can lead to an important separation. The thermoelectric or *Peltier* effect is widely used to cool not too large bodies using an electric potential difference.

An interesting type of the coupled processes is the so-called *cotransport*, when a gradient in the concentration of one chemical species drives the transport of

another species. This can be a transport in the same direction as the principal transport, when the principal component driving the flux of the other component is called a *symporter*. In the opposite case, the induced transport of the other species happens in the opposite direction and the principal component driving the flux is called an *antiporter*. This type of cotransport plays an important role in biochemical transport phenomena across membranes and offers a sensitive means to bio-regulation. The first example discovered was the transport of glucose induced by the gradient of sodium ions.

There are two rules worth mentioning concerning coupled processes. *Curie's theorem* tells that coupled processes can only occur within the same rank of forces and fluxes; i.e., if both force and flux concern scalar quantities, or if both of them concern vector quantities. *Onsager's reciprocity relationships* tell that the coupled coefficient for the transport of an extensive quantity X_1 driven by the conjugate intensive quantity to another extensive quantity X_2 – let us denote it by α_{12} – should be the same as the inverse equivalent α_{21} (however, within the approximation of local equilibrium).

Problems

1. Let us model the dissolution of sugar in a cup of tea by carefully stratifying a large quantity of 80°C temperature water onto a saturated solution of sucrose at the bottom of a tall cylinder. Let us assume that at $t = 0$, the total amount of sucrose, $n_0 = 0.01$ mol (3.423 g), is at the plane of the bottom of the cup in a negligibly thin layer. Let us consider that the cylinder is infinitely tall compared to the distance sugar would diffuse during the experiment and ignore any convective flow inside the cylinder. Estimate the time needed for the sucrose concentration to attain $c = 0.001$ mol dm⁻³ (roughly 0.34 g L⁻¹) 1 cm away from the bottom. The diffusion coefficient of sucrose is 6.73×10^{-6} cm² s⁻¹ and the cross-sectional area of the cup is 25 cm².

Solution: The concentration profile of sucrose along the vertical direction z can be described by Eq. (11.18). By substituting the given quantities and $z = 1$ cm, we get the equation

$$10^{-6} \text{ mol cm}^{-3} = \frac{0.01 \text{ mol}}{25 \text{ cm}^2 \sqrt{6.73 \times 10^{-6} \text{ cm}^2 \text{ s}^{-1} \cdot \pi t}} e^{-\frac{(1\text{cm})^2}{4 \cdot 6.73 \times 10^{-6} \text{ cm}^2 \text{ s}^{-1}}}$$

It is obvious that we can eliminate units by “simplification” using mol, cm, and s throughout, thus having only dimensionless numbers left in the exponential equation. Solution of this equation can be found by taking the logarithm of both sides, providing 5238.1 s, i.e., 87.3 min. (Obviously, it is worth stirring if we want sugar to be dissolved in our cup before the tea gets cold.)

2. A block of metal is surrounded by adiabatic walls, except for a thermally conductive rod inside the wall connecting it to the environment. The initial temperature (at $t = 0$) of the metal block is $T_0 = 100.00^\circ\text{C}$, and its heat capacity is $C = 600$ kJ K⁻¹. The thermal conductivity of the 5 mm long rod having a cross section of 1 mm² is $\lambda = 200$ W m⁻¹ K⁻¹. The environment has a constant temperature of $T_e = 20.00^\circ\text{C}$. We follow the temperature difference of the environment and the metal block using a digital thermometer having a precision of 0.01°C.

Calculate the time needed for the metal block to cool down to 60°C and to cool down to the temperature of the surroundings as measured by the digital thermometer.

Solution: We can write (11.6) – Fourier’s law – for this problem as follows:

$$\frac{1}{A} \frac{dQ}{dt} = -\lambda \frac{dT}{dz}.$$

By supposing that the temperature gradient is uniform along the rod of length l , we can replace dT/dz by the finite difference ratio $(T - T_e)/l$. The infinitesimal heat transfer dQ can be expressed with the heat capacity as $dQ = CdT$. Thus, the original differential equation can be written as follows:

$$\frac{1}{A} C \frac{dT}{dt} = -\lambda \frac{T - T_e}{l}.$$

By rearranging, we get the differential equation

$$\frac{dT}{dt} = \lambda \frac{A}{C} \frac{T_e - T}{l}$$

to solve. The solution of this equation with the boundary condition $T_0 = 100^\circ\text{C}$ at $t = 0$ yields the function:

$$T(t) - T_e = (T_0 - T_e)e^{-\frac{\lambda A t}{C l}}.$$

To get the time necessary to cool down to 60°C (by 40°C; half of the original difference), we have to substitute the difference $T(t) - T_e = 40^\circ\text{C}$ and solve the resulting exponential equation. The solution is 10 397.3 s, which is equivalent to 2 h and 58.3 min. The time necessary to cool down to the environmental temperature $T_e = 20^\circ\text{C}$ can be calculated by putting the temperature difference to $T(t) - T_e \leq 0.005^\circ\text{C}$, i.e., below the precision of the digital thermometer. The solution in this case is $t \geq 145205$ s, which is equivalent to 2420 h and 2 min. The results indicate that the cool-down rate diminishes dramatically with the decrease of temperature difference.

Further Reading

Atkins P, de Paula J (2009) Physical chemistry, 9th edn. Oxford University Press, Oxford
 Balzhiser RE, Samuels MR, Eliassen JD (1972) Chemical engineering thermodynamics – the study of energy, entropy, and equilibrium. Prentice-Hall, Englewood Cliffs, NJ
 Onsager L (1931) Reciprocal relations in irreversible processes I. Phys Rev 37:405–426
 Silbey LJ, Alberty RA, Mounji GB (2004) Physical chemistry, 4th edn. Wiley, New York

Appendix

A1 Useful Relations of Multivariate Calculus

From a mathematical point of view, thermodynamics is a subject mostly based on relations of differentials and partial derivatives of multivariate functions. Many of these relations are of paramount importance in thermodynamics. This part of the appendix contains a collection of the most important relations, usually without any proof, only as “rules” that can be applied. Thermodynamic chapters of the book do not always make explicit reference to the rules described in the Appendix, but the rules are always mentioned under the same name as described here.

A1.1 Differentiation of Multivariate Functions

Let us consider the bivariate function f depending on the variables x_1 and x_2 . Rules that apply for this function are readily generalized for more than two variables, but it is easier to describe the rules in case of only two of them.

The *partial derivative* of the function f is the function we get in a similar manner as an ordinary derivative with the differentiation of a univariate function, considering one of the variables of the bivariate function $f(x_1, x_2)$ as a constant during the differentiation. A bivariate function has two partial derivatives:

$$\left(\frac{\partial f}{\partial x_1}\right)_{x_2} \quad \text{and} \quad \left(\frac{\partial f}{\partial x_2}\right)_{x_1}. \quad (\text{A1.1})$$

To discern partial differentiation from ordinary one (i.e., of a univariate function) we use the symbol ∂ . (When reading formulae, ∂ is also pronounced as “dee”; “dee ef over dee ex one”, or, if we want to stress that it is a partial derivative, we can say “dee ef partial over dee ex one”.) It is common practice in thermodynamics (and it is also adopted in this book) to denote a function and its value with the same

symbol; thus, it is not always clear what the actual function is whose derivative is considered. This is the reason why partial derivatives are written within brackets, and variables not involved in the derivation are shown as lower right subscripts of the closing bracket, thus identifying the proper function. We read such notation as “the partial derivative of f with respect to x_1 when x_2 is constant”. Note, however, that x_2 is only constant from the point of view of derivation; it is clear that the partial derivative is in general a function of *both* variables.

The *total differential* of a function can be written with the help of the partial derivatives as follows:

$$df = \left(\frac{\partial f}{\partial x_1} \right)_{x_2} dx_1 + \left(\frac{\partial f}{\partial x_2} \right)_{x_1} dx_2. \quad (\text{A1.2})$$

The symbol df means the (infinitesimal) *change* of the function as a consequence of the (infinitesimal) *increments* dx_1 and dx_2 of the variables x_1 and x_2 . By summing products of partial derivatives and increments, we can specify arbitrary increments, not only that of a function of the variables. Thus, the expression (A1.2) is a total differential (or exact differential) only if the function whose change is on the left-hand side is a unique function of the variables of derivation on the right-hand side. From a thermodynamic point of view, it means that f is a state function uniquely determined by the thermodynamic variables x_1 and x_2 .

The *second partial derivatives* (also called as *second-order* partial derivatives) of the function f —again, similarly to the second derivative of a univariate function—are the partial derivatives of the (first-order) partial derivatives. There are more second partial derivatives than first ones, as we can differentiate each (first-order) partial derivative with respect of all the variables. Let us denote the first-order partial derivatives in the following way:

$$\left(\frac{\partial f}{\partial x_1} \right)_{x_2} = g_1 \quad \text{and} \quad \left(\frac{\partial f}{\partial x_2} \right)_{x_1} = g_2. \quad (\text{A1.3})$$

Accordingly, the “pure” second partial derivatives can be written as

$$\left(\frac{\partial^2 f}{\partial x_1^2} \right)_{x_2} = \left(\frac{\partial g_1}{\partial x_1} \right)_{x_2}, \quad \left(\frac{\partial^2 f}{\partial x_2^2} \right)_{x_1} = \left(\frac{\partial g_2}{\partial x_2} \right)_{x_1}, \quad (\text{A1.4})$$

and the “mixed” second partial derivatives as

$$\frac{\partial}{\partial x_2} \left(\frac{\partial f}{\partial x_1} \right)_{x_2} = \left(\frac{\partial^2 f}{\partial x_2 \partial x_1} \right) = \left(\frac{\partial g_1}{\partial x_2} \right)_{x_1}; \quad \frac{\partial}{\partial x_1} \left(\frac{\partial f}{\partial x_2} \right)_{x_1} = \left(\frac{\partial^2 f}{\partial x_1 \partial x_2} \right) = \left(\frac{\partial g_2}{\partial x_1} \right)_{x_2}. \quad (\text{A1.5})$$

The symbol $\partial/\partial x_2$ denotes the action of taking the partial derivative with respect to x_2 ; thus, it is called a *differential operator*. It has the effect of partial

differentiation on the function written after the operator. (It can also be called a *partial differential operator*.) Thus, the expression $(\partial^2 f / \partial x_1^2)_{x_2}$ does *not* contain the square of the symbol ∂ or the square of x_1 , but two subsequent applications of the differential operator. Accordingly, it is read as “dee two ef over dee ex two”.

For the second-order derivatives of multivariate functions, *Young’s theorem* holds; second partial derivatives are equal, irrespective of the order of differentiation. We can write it formally for the above function as¹:

$$\left(\frac{\partial^2 f}{\partial x_2 \partial x_1} \right) = \left(\frac{\partial^2 f}{\partial x_1 \partial x_2} \right). \quad (\text{A1.6})$$

The *second-order differential* of the function $f(x_1, x_2)$ can be written with the help of its second partial derivatives as follows:

$$d^2f = \left(\frac{\partial^2 f}{\partial x_1^2} \right)_{x_2} (dx_1)^2 + \left(\frac{\partial^2 f}{\partial x_2^2} \right)_{x_1} (dx_2)^2 + 2 \left(\frac{\partial^2 f}{\partial x_1 \partial x_2} \right) dx_1 dx_2. \quad (\text{A1.7})$$

Note that the equality of the mixed second partial derivatives is included in the above definition. Let us rewrite (A1.6) using the notation introduced in (A1.3):

$$\left(\frac{\partial g_1}{\partial x_2} \right)_{x_1} = \left(\frac{\partial g_2}{\partial x_1} \right)_{x_2}. \quad (\text{A1.8})$$

In thermodynamics, the theorem stating the equality of mixed second partial derivatives is not referred to as Young’s theorem but – written in the above form – as a *Maxwell relation*. To facilitate the generalization for more than two variables, Maxwell relations and the second-order differential is given below for a trivariate function $h(x_1, x_2, x_3)$. These Maxwell relations contain the following variables:

$$\left(\frac{\partial h}{\partial x_1} \right)_{x_2, x_3} = g_1; \quad \left(\frac{\partial h}{\partial x_2} \right)_{x_1, x_3} = g_2; \quad \text{and} \quad \left(\frac{\partial h}{\partial x_3} \right)_{x_1, x_2} = g_3. \quad (\text{A1.9})$$

Equalities of the second derivatives can be written as follows:

$$\begin{aligned} \left(\frac{\partial^2 h}{\partial x_2 \partial x_1} \right)_{x_3} &= \left(\frac{\partial^2 h}{\partial x_1 \partial x_2} \right)_{x_3}, & \left(\frac{\partial^2 h}{\partial x_3 \partial x_1} \right)_{x_2} &= \left(\frac{\partial^2 h}{\partial x_1 \partial x_3} \right)_{x_2} \\ & & \left(\frac{\partial^2 h}{\partial x_2 \partial x_3} \right)_{x_1} &= \left(\frac{\partial^2 h}{\partial x_3 \partial x_2} \right)_{x_1}. \end{aligned} \quad (\text{A1.10})$$

¹Second-order partial derivatives can be arranged in a matrix called the *Hessian matrix*, named after the German mathematician Ludwig Otto Hesse (1811–1874). According to Young’s theorem, the Hessian matrix is symmetrical.

They can be rewritten by substitution of the first partial derivatives as defined above:

$$\left(\frac{\partial g_1}{\partial x_2}\right)_{x_1, x_3} = \left(\frac{\partial g_2}{\partial x_1}\right)_{x_2, x_3}, \quad \left(\frac{\partial g_1}{\partial x_3}\right)_{x_1, x_2} = \left(\frac{\partial g_3}{\partial x_1}\right)_{x_2, x_3},$$

$$\left(\frac{\partial g_3}{\partial x_2}\right)_{x_1, x_3} = \left(\frac{\partial g_2}{\partial x_3}\right)_{x_1, x_2}. \quad (\text{A1.11})$$

These forms are properly called as Maxwell relations.

The second-order differential of the function $h(x_1, x_2, x_3)$ can be written as follows:

$$d^2h = \left(\frac{\partial^2 h}{\partial x_1^2}\right)_{x_2, x_3} (dx_1)^2 + \left(\frac{\partial^2 h}{\partial x_2^2}\right)_{x_1, x_3} (dx_2)^2 + \left(\frac{\partial^2 h}{\partial x_3^2}\right)_{x_1, x_2} (dx_3)^2$$

$$+ 2\left(\frac{\partial^2 h}{\partial x_1 \partial x_2}\right)_{x_3} dx_1 dx_2 + 2\left(\frac{\partial^2 h}{\partial x_1 \partial x_3}\right)_{x_2} dx_1 dx_3 + 2\left(\frac{\partial^2 h}{\partial x_2 \partial x_3}\right)_{x_1} dx_2 dx_3. \quad (\text{A1.12})$$

A1.2 Differentiation of Composite Functions

Let us consider the case when the variables of the function $f(x_1, x_2)$, x_1 and x_2 , are not independent, but both are functions of a third variable u . In this case, the increments dx_1 and dx_2 in (A1.2) can be written as

$$dx_1 = \frac{dx_1}{du} du \quad \text{and} \quad dx_2 = \frac{dx_2}{du} du. \quad (\text{A1.13})$$

By resubstituting this in the total differential (A1.2), we get:

$$df = \left[\left(\frac{\partial f}{\partial x_1}\right)_{x_2} \frac{dx_1}{du} + \left(\frac{\partial f}{\partial x_2}\right)_{x_1} \frac{dx_2}{du} \right] du. \quad (\text{A1.14})$$

This can also be written as

$$\frac{df}{du} = \left(\frac{\partial f}{\partial x_1}\right)_{x_2} \frac{dx_1}{du} + \left(\frac{\partial f}{\partial x_2}\right)_{x_1} \frac{dx_2}{du}, \quad (\text{A1.15})$$

which is the equivalent of the *chain rule* for multivariate differentials.

Rules of differentiation concerning sums (differences), products and ratios of functions are also related to composite functions. Simplified relations (omitting variables) in case of two functions f and h are shown below:

$$d(f + h) = df + dh, \quad (\text{A1.16})$$

$$d(fh) = f dh + h df, \quad (\text{A1.17})$$

$$d\left(\frac{f}{h}\right) = \frac{h df - f dh}{h^2}. \quad (\text{A1.18})$$

A1.3 Differentiation of Implicit Functions

Let us consider the implicit function specified by the equation $F(x, y, z) = 0$, and the variable w which can be given as a function of any two of the variables x, y, z . (In thermodynamics, this means that x, y, z and w are state variables, and x, y, z and w can be expressed as explicit functions from the implicit function F and that the system whose state is described by the functions mentioned has two degrees of freedom.)

The extension of the chain rule for partial derivatives can be written as follows:

$$\left(\frac{\partial x}{\partial w}\right)_z = \left(\frac{\partial x}{\partial y}\right)_z \left(\frac{\partial y}{\partial w}\right)_z. \quad (\text{A1.19})$$

Using this rule, we can express the partial derivative of a function knowing the partial derivatives of two other functions if their variables are in accordance with the above formula.

To differentiate an inverse function, the following relation can be used:

$$\left(\frac{\partial x}{\partial y}\right)_z = \frac{1}{\left(\frac{\partial y}{\partial x}\right)_z}. \quad (\text{A1.20})$$

To change a variable, we can use the following identity, where the variable w is changed for z :

$$\left(\frac{\partial x}{\partial y}\right)_z = \left(\frac{\partial x}{\partial y}\right)_w + \left(\frac{\partial x}{\partial w}\right)_y \left(\frac{\partial w}{\partial y}\right)_z. \quad (\text{A1.21})$$

The following cyclic rule (or triple product rule) can also be applied in thermodynamics:

$$\left(\frac{\partial x}{\partial y}\right)_z \left(\frac{\partial y}{\partial z}\right)_x \left(\frac{\partial z}{\partial x}\right)_y = -1. \quad (\text{A1.22})$$

Here, in both the numerator and the denominator, as well as in the subscripts outside the brackets, variables follow each other always in the same order; in other words, they are cyclic permutations of the set $x-y-z$. This rule can be applied, for example, if we want to get a derivative from the one whose variable is the “constant” (i.e., outside the bracket) so that this variable should be inside the bracket, and another one appears outside. As an example, the partial derivative where the variable z is outside the bracket and expressed with derivatives where z is within the bracket can be obtained with the following rearrangement:

$$\left(\frac{\partial x}{\partial y}\right)_z = -\left(\frac{\partial z}{\partial y}\right)_x \left(\frac{\partial x}{\partial z}\right)_y \quad \text{or} \quad \left(\frac{\partial x}{\partial y}\right)_z = -\frac{\left(\frac{\partial z}{\partial y}\right)_x}{\left(\frac{\partial z}{\partial x}\right)_y}. \quad (\text{A1.23})$$

However, it is easier to memorize the rule in the form of the triple product equal to -1 .

A1.4 Integration of Multivariate Functions

Let us write the total differential of the function $f(x, y)$ in the following form:

$$df = \left(\frac{df}{dx}\right) dx + \left(\frac{df}{dy}\right)_x dy = g_1 dx + g_2 dy. \quad (\text{A1.24})$$

This can be integrated in several ways. In thermodynamics, it is convenient to use simple constraints to calculate changes of state functions. (Changes of state functions do not depend on the path of the change but the starting point and the endpoint.) Accordingly, we can perform an integration first while keeping y constant; i.e., applying the condition $dy = 0$, which only concerns the first term. Having done this, we can continue integrating the second term while keeping x constant; i.e., applying the condition $dx = 0$. The formal statement of this procedure can be written in the following way:

$$\Delta_0^1 f = f_1(x_1, y_1) - f_0(x_0, y_0) = \int_{x_0, y_0}^{x_1, y_1} df = \int_{x_0, y_0}^{x_1, y_0} g_1 dx + \int_{x_1, y_0}^{x_1, y_1} g_2 dy. \quad (\text{A1.25})$$

For the integration of a state function $f(x, y)$, the following relation can also be applied:

$$\oint df = \oint (g_1 dx + g_2 dy) \equiv 0. \quad (\text{A1.26})$$

Fig. A1.1 Integrating a bivariate function; first with respect to one and then with respect to the other variable

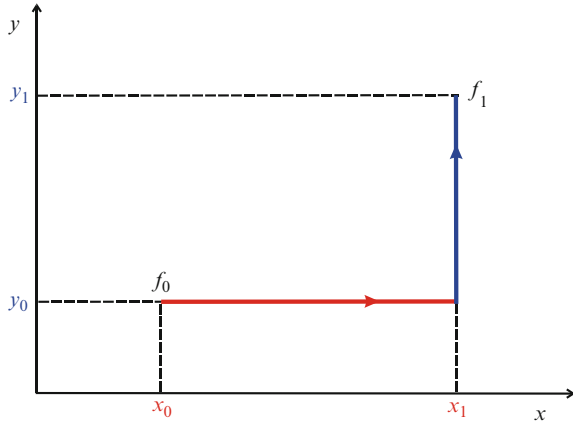

The symbol \oint (*cyclic integral* or *closed contour integral*) means integration along a closed curve; i.e., a path that returns to its starting point. In case of a state function, it is equivalent to a cyclic process where the state of the system returns to the initial state; thus, there is no change of state by the end of the process. The rationale behind this relation and (A1.25) is the same; the change of a state function is independent of the path of the change.

A1.5 The Euler Equation for Homogeneous First-Order Functions

Functions that are transformed as a consequence of a λ -fold multiplication of their variables according to the relation

$$f(\lambda x_1, \lambda x_2, \dots, \lambda x_r) = \lambda^n f(x_1, x_2, \dots, x_r) \tag{A1.27}$$

are called *homogeneous functions of order n*.

Let us differentiate both sides of the above equation with respect to λ . On the right-hand side, the function $f(x_1, x_2, \dots, x_r)$ does not depend on λ ; thus, the derivations yield $n\lambda^{n-1} f$. On the left-hand side, the derivation can be performed using the chain rule and summing for all variables x_i the following terms:

$$\frac{\partial f(\lambda x_1, \lambda x_2, \dots, \lambda x_r)}{\partial(\lambda x_i)} \frac{\partial(\lambda x_i)}{\partial \lambda} = \left(\frac{\partial f}{\partial(\lambda x_i)} \right)_{x_j \neq i} x_i. \tag{A1.28}$$

This result is valid for any value of λ . By substituting $\lambda = 1$, we get the following result:

$$nf(x_1, x_2, \dots, x_r) = \sum_{i=1}^r \left(\frac{\partial f}{\partial x_i} \right)_{x_{j \neq i}} x_i. \quad (\text{A1.29})$$

This is called the *Euler equation*. If the function $f(x_1, x_2, \dots, x_r)$ is a *homogeneous first-order function* of its variables x_1, x_2, \dots, x_r , it can be written in the following form:

$$f(x_1, x_2, \dots, x_r) = \sum_{i=1}^r \left(\frac{\partial f}{\partial x_i} \right)_{x_{j \neq i}} x_i. \quad (\text{A1.30})$$

The above equation – the *Euler equation for a homogeneous first-order function* has frequent application in thermodynamics.

Note that we can obtain this equation by substituting the increment of f as a function of the variables incremented by a ratio of $(1 + dv):1$ – i.e., $x_i dv$ – into the total differential

$$df(x_1, x_2, \dots, x_r) = \sum_{i=1}^r \left(\frac{\partial f}{\partial x_i} \right)_{x_{j \neq i}} dx_i, \quad (\text{A1.31})$$

according to the homogeneous first-order property:

$$df(x_1, x_2, \dots, x_r) = \sum_{i=1}^r \left(\frac{\partial f}{\partial x_i} \right)_{x_{j \neq i}} x_i dv, \quad (\text{A1.32})$$

and integrating the expression from $v = 0$ to 1. From this derivation of the Euler equation it is also clear that, if there were some variables for which the function f is homogeneous zero-order, they would contribute by zero to the increment df ; thus, they should simply be omitted from the sum.

A2 Changing Extensive Variables to Intensive Ones: Legendre Transformation

Summarizing energy-like potential functions in Sect. 4.4, we have mentioned that they can be obtained from the function $U(S, V, \mathbf{n})$ using *partial Legendre transformations*. This transformation changes one or two independent variables out of $S, V, n_1, n_2, \dots, n_K$ for the derivative of the respective variable. In this Appendix, we shall first describe the Legendre transformation from a mathematical point of view, and then we shall derive important entropy-like potential functions obtained by Legendre transformation from the entropy function $S(U, V, \mathbf{n})$.

A2.1 Legendre Transformations

For the sake of simplicity, let us consider the univariate function $y = f(x)$, and denote its derivative with respect to x by m :

$$\frac{dy}{dx} = f'(x) = m. \quad (\text{A2.1})$$

We would like to get a function $g(m)$ equivalent to the original function $f(x)$, so that the original function $f(x)$ can be calculated from $g(m)$. It is obvious that the function $y = h(m)$ does not have the required property as the equation specifying this function is a *differential equation*, whose solution yields the function $y = f(x)$ only to within an arbitrary additive constant of integration. To get a unique transformation, we can make use of the geometrical observation that the derivatives can be considered as tangent lines of the graph of the function. (The graph of the univariate function is a two-dimensional curve.) Each tangent line determines one point of the function (the point of tangency); thus, all the tangent lines determine the entire function, as it is illustrated in Fig. A2.1.

Accordingly, the proper transformation is expected to be derived from the tangent lines; specifying the loci (x, y) on the graph of the function $y = f(x)$ using the slope m and the intercept a which determine the tangent lines. By applying this technique, we determine the graph using the function $a = g(m)$, instead of the function $y = f(x)$ itself. By doing so, we arrive to our original goal of changing the variable x for m , as the function $g(m)$ completely determines the original function. We call Legendre transform the one that yields the function $a = g(m)$ from the original function $y = f(x)$.

The analytical formulation of the transformation is based on the equation of the tangent line. The tangent passes at the point (x, y) , its slope is m and its intercept is a . From the equation of a line going through a point, having a slope m ;

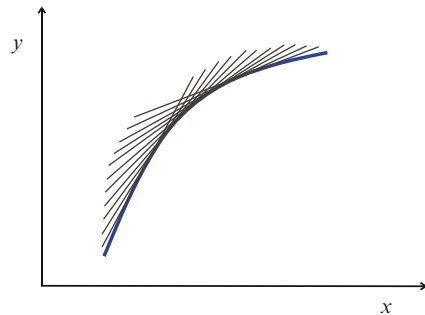

Fig. A2.1 The envelope of the tangent lines of the function $y = f(x)$ traces the function itself

$$m = \frac{y - a}{x - 0}, \quad (\text{A2.2})$$

the searched-for relation is easily explained:

$$a = y - mx. \quad (\text{A2.3})$$

From the original function

$$y = f(x) \quad (\text{A2.4})$$

and its derivative with respect to x ,

$$m = f'(x), \quad (\text{A2.5})$$

we can express the explicit formula of the transformed function as follows:

$$a = g(m). \quad (\text{A2.6})$$

The function g is called the *Legendre transform* of the function f .

The derivative $g' = da/dx$ can also be determined from the above equations. Based on (A2.3), let us write the differential of the product and the difference in it; then let us substitute the relation $dy = m dx$:

$$da = dy - m dx - x dm = -x dm. \quad (\text{A2.7})$$

From the result obtained, it is clear that the searched-for derivative is

$$\frac{da}{dm} = -x. \quad (\text{A2.8})$$

By summing up the above results, we can state the following. It is possible to construct a function whose independent variable is the derivative m of the original function, such that the original function $y(x)$ can be uniquely determined from this new function. The new function – the Legendre transform of $y(x)$ – is $a = y - mx$; it is a function of m and its derivative with respect to m is $-x$. The original function can be reconstructed by inverse Legendre transformation as $y = a + mx$. (These rules have been formulated in Sect. 4.4.)

The rules can be applied similarly for a multivariate function if we perform the transformation with respect to one variable only, as the transformation does not have any effect on the other variables. A Legendre transformation with respect to two variables can be formulated based on considerations in a three-dimensional subspace, instead of a two-dimensional section. The three-dimensional “section” is a continuous surface; the partial derivatives of the function determine tangent planes of this surface. By writing the equations of these planes, we can determine

the Legendre transform and its derivatives, similarly to the one-dimensional case. The procedure can be extended to all the independent variables as well. If the transformation is not performed for all the variables but only some of them, it is called a *partial Legendre transformation*. Partial transformation has been applied to derive the function $F(T, V, \mathbf{n})$, using a transformation of the function $U(S, V, \mathbf{n})$ with respect to S ; to derive $H(S, P, \mathbf{n})$ with the help of a transformation with respect to V ; and to get the function $G(T, P, \mathbf{n})$ by transforming $U(S, V, \mathbf{n})$ with respect to both S and V .

A2.2 Legendre Transformation of the Entropy Function

Energy-like potential functions as results of partial Legendre transformations of the function $U(S, V, \mathbf{n})$ were introduced in thermodynamics by Gibbs in 1875. Six years before, Massieu² proposed entropy-like potential functions as a result of partial Legendre transformations of the function $S(U, V, \mathbf{n})$ to solve some thermodynamic problems in a simple way. This is the reason to call the Legendre transform with respect to two variables as Gibbs potential (or Gibbs function), and the entropy transform with respect to the variable U as *Massieu function*. The Legendre transform of the entropy function with respect to U and V was frequently used by Planck in his papers on statistical thermodynamics; thus, it is usually called as *Planck function*. (However, both of them are called sometimes as Massieu functions.)

The transformation of the function $S(U, V, \mathbf{n})$ can be performed using its derivatives with respect to U and V (i.e., $1/T$ and P/T) according to the following considerations. The transformation with respect to V is the function

$$X = S - \frac{P}{T}V. \quad (\text{A2.9})$$

The equation $X = X(U, P/T, \mathbf{n})$ defining this function is a fundamental equation. The total differential of this function can be written as follows:

$$dX = \frac{1}{T}dU - Vd\left(\frac{P}{T}\right) - \sum_{i=1}^K \frac{\mu_i}{T}dn_i. \quad (\text{A2.10})$$

This function cannot be expressed in a simple way from the energy-like potential functions and is not used in thermodynamic practice; it does not even have a name. (It does not suit to any practical problem as it would need a reservoir which keeps P/T constant, while $1/T$ should change, which is not easily feasible.)

The transformation of S with respect to V is the *Massieu function*

²François Jacques Dominique Massieu (1832–1896) was a French mathematician and physicist.

$$J = S - \frac{1}{T}U. \quad (\text{A2.11})$$

The specification of this function in the form $J = J(1/T, V, \mathbf{n})$ is a fundamental equation. The total differential of the function can be written as follows:

$$dJ = -Ud\left(\frac{1}{T}\right) + \frac{P}{T}dV - \sum_{i=1}^K \frac{\mu_i}{T}dn_i. \quad (\text{A2.12})$$

The function J can be easily expressed with the free energy F as follows:

$$J = S - \frac{U}{T} = -\frac{F}{T}. \quad (\text{A2.13})$$

This is the reason to use also the function $J = J(T, V, \mathbf{n})$ in thermodynamical praxis. The total differential of this latter function can be written as follows:

$$dJ = dS - \frac{TdU - UdT}{T^2}. \quad (\text{A2.14})$$

Substitution of the total differential (2.26) of the entropy function $S(U, V, \mathbf{n})$ yields:

$$dJ = \frac{1}{T}dU + \frac{P}{T}dV - \sum_{i=1}^K \frac{\mu_i}{T}dn_i - \frac{1}{T}dU + \frac{U}{T^2}dT. \quad (\text{A2.15})$$

By omitting terms whose sum results in zero and rearranging, we get the usual form of the total differential of the function $J = J(T, V, \mathbf{n})$:

$$dJ = \frac{U}{T^2}dT + \frac{P}{T}dV - \sum_{i=1}^K \frac{\mu_i}{T}dn_i. \quad (\text{A2.16})$$

From this result, it is easily seen that the partial derivative of the function J with respect to T is U/T^2 , which is usually written in the following form:

$$\left(\frac{\partial(F/T)}{\partial T}\right)_{V, \mathbf{n}} = -\frac{U}{T^2}. \quad (\text{A2.17})$$

The transformation of S with respect to U and V is the *Planck function*:

$$Y = S - \frac{1}{T}U - \frac{P}{T}V. \quad (\text{A2.18})$$

By specifying this function in the form $Y = Y(1/T, P/T, \mathbf{n})$, we get a fundamental equation. The total differential of the Planck function can be written as follows:

$$dY = -Ud\left(\frac{1}{T}\right) - Vd\left(\frac{P}{T}\right) - \sum_{i=1}^K \frac{\mu_i}{T} dn_i. \quad (\text{A2.19})$$

The function Y can be expressed from the function G as follows:

$$Y = S - \frac{U}{T} - \frac{PV}{T} = -\frac{G}{T}. \quad (\text{A2.20})$$

Accordingly, we can easily express Y as a function of T , P and \mathbf{n} . The total differential of this function $Y = Y(T, P, \mathbf{n})$ can be written based on the above equation:

$$dY = dS - \frac{TdU - UdT}{T^2} - \frac{T(PdV + VdP) - PVdT}{T^2}. \quad (\text{A2.21})$$

Upon substitution of the total differential (2.26) of the entropy function, the elimination of terms that sum to zero, and the substitution of H in place of $U - PV$ we get:

$$dY = \frac{H}{T^2} dT - \frac{V}{T} dP - \sum_{i=1}^K \frac{\mu_i}{T} dn_i. \quad (\text{A2.22})$$

It is easily seen that the partial derivative of the Planck function $Y(T, P, \mathbf{n})$ with respect to temperature is H/T^2 , which can also be written in the following form:

$$\left(\frac{\partial(G/T)}{\partial T}\right)_{P,\mathbf{n}} = -\frac{H}{T^2}. \quad (\text{A2.23})$$

This relation has a distinct name; it is called the *Gibbs–Helmholtz equation*. [(A2.17) is also called Gibbs–Helmholtz equation, but it is less frequently used in the chemical praxis.]

A3 Classical Thermodynamics: The Laws

The expression “classical” in the title of this section means that the theory to be described here was the first one formulating the exact science of thermodynamics. As it is mentioned in the Introduction, this theory had been elaborated as a result of an attempt in the middle of nineteenth century to improve the efficiency of

transformation of heat into mechanical work. Steam engines were already in use in the eighteenth century. (Their highly developed versions, steam turbines are largely used even nowadays in thermal power plants as well as in nuclear power plants.) These engines were first constructed by mechanics based on their empirical experience, without any theoretical background. The first key step to optimize their performance was made by James Watt. He called attention to the importance of the (missing) theoretical background already in the 1760s.

The first study that had a great impact on the theory of heat engines was written by Sadi Carnot. Though it was published in 1824 (see Sect. 5.2), it remained unknown to the scientific community for more than 20 years. Development of the theory had a great impact as a consequence of experimental studies made by James Joule (see Sect. 5.4.3), who performed a series of carefully planned measurements to confirm that the quantity of heat transferred is “equivalent” to the quantity of work transferred to a system. Following the publication of these studies, many scientists contributed to the development of the theory of heat. The comprehensive treatment of what we call today thermodynamics has been written by Rudolf Clausius in 1867, and in a more general approach by Henry Poincaré³ in 1892. At the beginning of the twentieth century, several scientists have reformulated the theoretical basis. One of the consequences of these activities is that the second law of thermodynamics has more than ten equivalent wordings.

Classical thermodynamics has retained the character of its historical development. Physical quantities and relations are formulated in a “language” of experimental evidence concerning heat engines. Another feature is that “heat” is thought of within the framework of the theory as a distinct substance, as statistical physics based on microscopical considerations was only moderately successful in explaining thermal phenomena at that time. Thus, the laws of thermodynamics are describing heat as an “imponderable fluid,” which can flow from one body into another. (Telltale examples are expressions still used nowadays such as heat flow and heat capacity.) In the rest of this part of the appendix, we give a concise description of classical thermodynamics which is based on an exact mathematical background but also reflects the physical meaning of the laws. We will not treat all the details; instead we often make reference to what is described in the chapters on the postulates of thermodynamics.

A3.1 Zeroth Law and Temperature

Basic statements of classical thermodynamics are termed as *laws* in English, which is related to the original German name *Hauptsatz*⁴ used for them. The order of the

³Jules Henri Poincaré (1852–1912) was a French mathematician and theoretical physicist. His activity was most important in the field of relativity theory, but he also dealt with thermodynamics and quantum mechanics.

⁴The German word can be translated as “main proposition” or “independent clause”.

laws which is manifested in their numbering does not reflect either the historical order of their formulation, or their inclusion into the set of the laws. The first one that has been formulated (Carnot 1824) is the second law. Next came the first law (Joule 1847) and then the third one (Nernst⁵ 1907 and Planck⁶ 1911). Finally, it has been realized that, to have a complete set of postulates, a fourth law is also needed. However, due to its basic importance, it has been named as the *zeroth law*, as this latter clarifies the notion of equilibrium.

As thermodynamics was developing, it has become only slowly clarified that the theory is only valid for *equilibrium systems*; thus, the definition of a (thermodynamic) system seemed not to be necessary for a while. There was a distinction of isolated, adiabatic, closed and open systems, without mentioning the importance of this distinction. However, the theory was primarily based on considerations concerning isolated and closed adiabatic systems. It is due to this missing definition of the subject of thermodynamics that several textbooks still describe the (thermodynamic) system as “that part of the physical universe that is under consideration”, or “the part of the world in which we have a special interest”. The “rest of the world” is then called *surroundings*. Equilibrium is typically mentioned in context of relations containing the signs \leq or \geq , where equality refers to equilibrium (or *quasistatic* changes), and inequality to nonequilibrium changes.

Prior to the development of thermodynamics, mechanical quantities (energy, work, pressure, compressibility, etc.), geometrical quantities (volume, surface) and quantities related to electric, magnetic and gravitational interactions were already known. It was also known that the state of a simple closed system can be described in terms of only two variables: pressure and volume. (We use the term simple system in the same sense as in Sect. 2.1, when describing Postulate 1; i.e., the system can exchange only heat and volume work with its surroundings. Closeness also means that the chemical composition is not allowed to change.) The main task was to determine relevant quantities related to heat, based on these experimental evidences.

This goal is reflected in the **zeroth law**, which announces the *existence of thermal equilibrium* and specifies the intensive quantity characterizing this equilibrium. According to this law, thermodynamic (equilibrium) systems can be *arranged in a unique series* on the basis of their thermal states. If the order of two systems cannot be distinguished (they have the same ranking), their *temperature* is identical and they are in *thermal equilibrium* which relation is *transitive*. Transitivity is the consequence of ordering; if systems A and B are in equilibrium and systems A and C are also in equilibrium, then all of them should have the same ranking; thus, B and C should also be in equilibrium. It is the consequence of the zeroth law that

⁵Walter Hermann Nernst (1864–1941) was a German physicist and chemist. Besides the relation defining the potential of an electrode reaction, the third law of thermodynamics also bears his name. This latter made it possible to calculate chemical equilibrium constants from thermodynamic data. He received his Nobel-prize for this result in 1920.

⁶Max Planck (1858–1947) was a German physicist who wrote his Ph.D. thesis on the second law of thermodynamics. He initiated quantum theory by properly describing black-body radiation. He interpreted the zero value of entropy at 0 K temperature based on quantum mechanical reasoning.

temperature defined this way (let us denote it by the Greek letter θ) is necessarily a state function; thus, it can be specified as $\theta = f(P, V)$, a function of temperature and pressure. Due to the unicity of this function, it can be inverted with respect to any of its variables. Thus, both state functions $V = f_1(P, \theta)$ and $P = f_2(V, \theta)$ can be expressed from θ . As we shall see, these consequences have an important role in formulating the first law.

A3.2 First Law and Energy

As we have already mentioned, the notion of work has been known from mechanics, electric and magnetic theory already before the development of thermodynamics. Known expressions of the infinitesimal work were, e.g., $-PdV$, γdA , σdl , and $-Edq$; where A denotes surface, γ is the surface tension, l is the length, σ is the modulus of elasticity, q is the electric charge, and E is the electric potential.

Adiabatic systems (those which cannot exchange heat with the surroundings) had a great role in setting fundamental rules of thermodynamics. Joule made a series of experiments between 1843 and 1848 by filling a thermally isolated container with water, examining the change of the state of the water due to the introduction of work in different manners. He introduced work the following ways.

- By means of a paddle wheel operated by a falling weight; the turbulent motion of water resulted in heating the water.
- By means of a diathermal cylinder immersed into the water; the compression of the gas resulted in heating the cylinder and thus the water.
- By means of two iron blocks in close contact inside the water bath; rubbing the plates against each other resulted in heating the water.
- By means of a metal coil immersed into the water; an external electric generator turned by a falling weight produced electric current in the coil, thus heating the water.

The work done on the paddle wheel, the piston in the cylinder, rods rubbing the iron blocks and the electric generator was always the same as it has been produced by the same falling weight over the same height. He has measured that – within the experimental error – to raise the temperature of 1 pound of water by 1 F, always the same amount of work was needed. He could get the same temperature rise by making diathermal contact between 1 font of water in an external container and the test container, while the temperature of the external water bath decreased by 1 F. He concluded that – *independently of the way of delivery of either heat or work, the change in the state of the water is the same*. Similar behavior was already known from the theory of gravitational, electric or magnetic fields. It was a natural consequence of these experiments to suggest the existence of a *potential* whose value depends only on the *state* (e.g., the height in the gravitational field of Earth), but does not depend on the way of change (or on the *path*).

The above results can be formulated by stating that *there exists an internal energy U* , whose change in adiabatic systems can be written as follows:

$$U_2 - U_1 = W. \quad (\text{A3.1})$$

In a similar way, for changes when there is no work done on the system, and its energy can only change by means of heat delivery across a diathermal wall and then the same change of state can be characterized by the following relation:

$$U_2 - U_1 = Q. \quad (\text{A3.2})$$

As the state of a closed simple system can be changed merely via work or heat exchanged with its surroundings; in case of both interactions, the following equality should hold for the same change of state:

$$U_2 - U_1 = Q + W. \quad (\text{A3.3})$$

From a theoretical point of view, the most important consequence of these experiments is the *existence* of a *state function* $U = f(V, \theta)$. This function is unique, i.e., any changes $\Delta U = U_2 - U_1$ of this function due to interactions with the surroundings are independent of the way of interactions, or the “path” in the P, V, θ space. (This is, of course, true in either of the planes P, V or P, θ or θ, V .) This property of the potential U can also be formulated by stating that the change of U along any closed curve (where the initial state and the final state are identical) is zero:

$$\oint dU = 0. \quad (\text{A3.4})$$

Another consequence is that the expression

$$dU = \frac{\partial U}{\partial V} dV + \frac{\partial U}{\partial \theta} d\theta \quad (\text{A3.5})$$

is a total differential.

Despite these formally advantageous consequences, the **first law** of thermodynamics does not state any of the above relations. Instead, it usually is formulated as the differential form of the *conservation of energy* including heat effects:

$$dU = dQ + dW. \quad (\text{A3.6})$$

This relation stresses the fact that the conservation of energy is also valid if we include changes of energy via heat transfer. The symbol d makes it obvious that, while the value of the function U is uniquely determined by the state of the system [i.e., its differential can be given by (A3.5)], this is not true for either heat or work. Consequently, both Q and W are also dependent on the path of the change during the delivery of heat or work, not only on the initial and final state. Thus, we can also say that the *fundamental notions* of classical thermodynamics – work and heat – do not

uniquely determine the state of the system itself. That is why there was a need to derive strictly state-dependent functions from these two quantities. One of these derived functions is the *internal energy* contained in the first law.

A3.3 Second Law and Entropy

According to the first law, the extended principle of the conservation of energy is also valid in thermodynamics. However, there is a problem which does not occur either in mechanics, or in electrodynamics, or in magnetodynamics; spontaneous changes have a well-determined direction and will never occur spontaneously in the other direction. (In mechanics, if a point mass moves from A to B in a frictionless way and has a given momentum there, the exact opposite momentum would make it return to A, and its energy would change exactly with the same amount as when it moved from A to B.) If there is a heat effect accompanying changes, the original state cannot be restored with exactly the same amount of energy, except for some special cases. The consequence of this – among others – is also that heat engines cannot turn thermal energy (heat) completely to mechanical work. This latter problem was thoroughly treated by the book of Carnot published in 1824. In page 38 of the book, the following is written (in slightly modernized English translation of the French text⁷): “The motive power of heat is independent of the agents employed to realize it; its quantity is fixed solely by the temperatures of the bodies between which is effected, finally, the transfer of the heat.”

As it is written in Sect. 5.2, the efficiency of heat engines can be derived from the principle of conservation of energy as stated by the first law. Accordingly, the energy balance of the Carnot cycle shown in Fig. A3.1a can be written in the following way:

$$0 = \Delta U = Q + W = |Q_{\text{in}}| - |Q_{\text{out}}| + |W_{\text{in}}| - |W_{\text{out}}|. \quad (\text{A3.7})$$

From this, we can express the net work gained:

$$W_{\text{net}} = |W_{\text{out}}| - |W_{\text{in}}| = |Q_{\text{in}}| - |Q_{\text{out}}|. \quad (\text{A3.8})$$

The efficiency can be calculated as the ratio of the net work gained and the heat input:

$$\eta = \frac{|Q_{\text{in}}| - |Q_{\text{out}}|}{|Q_{\text{in}}|} = 1 - \frac{|Q_{\text{out}}|}{|Q_{\text{in}}|}. \quad (\text{A3.9})$$

⁷The original French text is the following: “La puissance motrice du feu est indépendante des agens mis en œuvre pour la réaliser; sa quantité est fixée uniquement par les températures des corps entre lesquels se fait en dernier résultat le transport du calorique.”

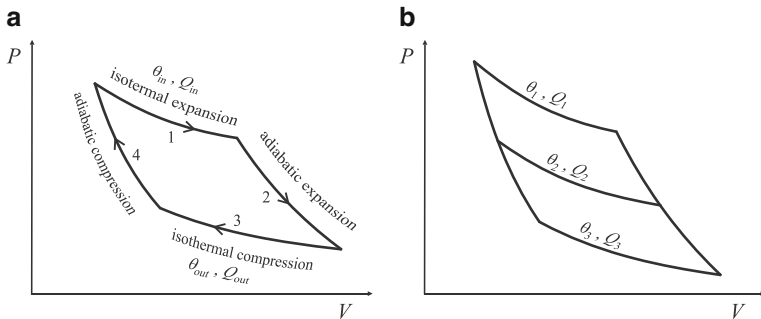

Fig. A3.1 Carnot cycle in a $P - V$ diagram. (a) Steps of the cycle are or also shown, along with the temperatures of the heat reservoirs and the transferred heat from (Q_{in}) and to (Q_{out}) them. (b) Three Carnot cycles are shown; working between reservoirs of temperatures of θ_1 and θ_2 , θ_2 and θ_3 , and θ_1 and θ_3 , respectively

We can conclude that the efficiency depends only on the *ratio* of the heat exchanged in the two isothermal steps; Q_{in} and Q_{out} . The above statement cited from Carnot tells that the efficiency only depends on the temperature of the two heat reservoirs; thus, we can write the relation

$$\frac{|Q_{in}|}{|Q_{out}|} = f(\theta_h, \theta_c), \tag{A3.10}$$

where θ_h is the temperature of the hotter, and θ_c is that of the colder reservoir.

Let us examine the three possible Carnot cycles shown in panel (b) of the figure and apply the equality (A3.10) for all the three:

$$\frac{|Q_1|}{|Q_2|} = f(\theta_1, \theta_2); \quad \frac{|Q_2|}{|Q_3|} = f(\theta_2, \theta_3); \quad \frac{|Q_1|}{|Q_3|} = f(\theta_1, \theta_3). \tag{A3.11}$$

Let us extend the ratio in the third equality in the following way:

$$\frac{|Q_1|}{|Q_3|} = \frac{|Q_1|}{|Q_3|} \frac{|Q_2|}{|Q_2|} = \frac{|Q_1|}{|Q_2|} \frac{|Q_2|}{|Q_3|}. \tag{A3.12}$$

Let us substitute into this identity the right-hand sides of the former three equalities:

$$f(\theta_1, \theta_3) = f(\theta_1, \theta_2) f(\theta_2, \theta_3). \tag{A3.13}$$

The left-hand side of this equation does not depend on θ_2 ; thus, the right-hand side cannot depend on it either. This condition is fulfilled if $f(\theta_1, \theta_3)$ can be explained in the form

$$f(\theta_1, \theta_3) = \frac{T(\theta_1)}{T(\theta_3)}, \quad (\text{A3.14})$$

where T is only the function of the respective θ_i . It is easy to see that, in this case, the condition is really fulfilled:

$$f(\theta_1, \theta_3) = \frac{T(\theta_1)}{T(\theta_3)} = \frac{T(\theta_1)}{T(\theta_2)} \frac{T(\theta_2)}{T(\theta_3)} = f(\theta_1, \theta_2) f(\theta_2, \theta_3). \quad (\text{A3.15})$$

Consequently, the function T defines a temperature scale such that the ratio of the heat transfer from the hot reservoir to that to the cold reservoir is identical to the ratio of the temperatures of the respective reservoirs:

$$\frac{|Q_h|}{|Q_c|} = \frac{T_h}{T_c}. \quad (\text{A3.16})$$

It is obvious that the temperature scale defined this way is independent of the medium of either the material of the heat reservoirs or the working fluid of the Carnot engine. The possibility to define temperature this way was first discovered by William Thomson – called Lord Kelvin after his ennoblement. The unit of the corresponding temperature scale is named after him as kelvin. It is also called *absolute temperature* as there is no need to make use of the state function of an ideal gas used to the previous definition of temperature; thus, it is independent of the material whose temperature is measured.

The above result has a much more important consequence compared to the definition of an absolute temperature. To explore this, let us consider that the absorbed heat Q_h (h for “hot”) and the rejected heat Q_c (c for “cold”) have opposite signs; thus, their ratio is also negative if we do not take absolute values. Accordingly, we can write the two equivalent relations for the efficiency of the Carnot engine in the following forms:

$$\eta = 1 + \frac{Q_c}{Q_h} \quad \text{and} \quad \eta = 1 - \frac{T_c}{T_h}. \quad (\text{A3.17})$$

As a consequence, we can also write the following three relations:

$$\frac{Q_c}{Q_h} = -\frac{T_c}{T_h}; \quad \frac{T_c}{T_h} + \frac{Q_c}{Q_h} = 0; \quad \frac{Q_h}{T_h} + \frac{Q_c}{T_c} = 0. \quad (\text{A3.18})$$

The third relation has its validity for the entire Carnot cycle; i.e., there exists a temperature scale such that isothermal quasistatic heat divided by this temperature results in a *state function* – as seen from the fact that this ratio summed for the entire cyclic process is zero. Clausius was the first to realize this property and proposed to

call it entropy, which became later denoted by the generally accepted letter S . The quotient can also be written for infinitesimal changes in the form:

$$\frac{dQ_{\text{quasistatic}}}{T} = dS. \quad (\text{A3.19})$$

The function S thus defined has all properties of a state function; its change is not dependent on the path of the change, only on the initial and final state, and its cyclic integral is zero. We can conclude that, while the quasistatic heat is not a state function, the denominator T ensures upon integration that the value of the quotient depends only on the initial and final state.

Let us turn our attention back to the direction of changes. Experimental evidence shows that there are losses during the operation of a heat engine if the cyclic process is not quasistatic. These losses diminish the useful work; thus, $\eta \leq \eta_{\text{qs}}$ for real processes. (Quasistatic processes are denoted by the subscript qs here and further.) The efficiency of the Carnot engines can be written in terms of the heat absorbed from and rejected to the heat reservoirs:

$$1 + \frac{Q_c}{Q_h} \leq 1 + \frac{Q_{c,\text{qs}}}{Q_{h,\text{qs}}}. \quad (\text{A3.20})$$

Subtracting one and multiplying the rest by -1 on both sides yields:

$$-\frac{Q_c}{Q_h} \geq -\frac{Q_{c,\text{qs}}}{Q_{h,\text{qs}}}. \quad (\text{A3.21})$$

We can replace the right-hand side – based on the relations in (A3.18) – by the quotient of the respective temperatures:

$$-\frac{Q_c}{Q_h} \geq \frac{T_c}{T_h} \quad \text{from which} \quad 0 \geq \frac{Q_h}{T_h} + \frac{Q_c}{T_c}. \quad (\text{A3.22})$$

From the result, we can conclude that the change of the function Q/T in isothermal changes during a cyclic process is *less* than zero, except when the process is quasistatic; in this case, it is exactly zero. We can formulate the same conclusion by writing the cyclic integral of this function:

$$\oint \frac{dQ}{T} \leq 0. \quad (\text{A3.23})$$

Let us apply this for a process in which a particular system is brought from state A to state B with losses (as it is called in classical thermodynamics, in an *irreversible process*), and then it is brought back to state A in a quasistatic process, as shown below:

$$A \xrightarrow{\text{irreversible}} B \xrightarrow{\text{quasistatic}} A. \quad (\text{A3.24})$$

The total change during the entire process can be written as follows:

$$\int_A^B \frac{dQ}{T} + \int_B^A \frac{dQ_{\text{qs}}}{T} < 0. \quad (\text{A3.25})$$

The second integration contains quasistatic heat; thus, the quotient dQ_{qs}/T can be replaced by dS :

$$\int_A^B \frac{dQ}{T} + \int_B^A dS < 0. \quad (\text{A3.26})$$

The inequality holds for infinitesimal changes as well (i.e., when A and B approach each other infinitely close):

$$\frac{dQ}{T} < dS. \quad (\text{A3.27})$$

This relation is valid for the case if there is an irreversible process involved. Thus, if we allow also for completely quasistatic processes, we should allow the equality as well:

$$dS \geq \frac{dQ}{T}. \quad (\text{A3.28})$$

The above inequality is the usual formal statement of the **second law** of thermodynamics. The connection between entropy and the direction of natural processes can be formulated most simply in an *isolated system*, which cannot exchange heat with its surroundings. In this case, the above equation simplifies to the following relation:

$$dS \geq 0. \quad (\text{A3.29})$$

This relation tells us that the entropy of isolated systems is increased in spontaneous (natural) processes, but it does not change in equilibrium. Consequently, the natural direction of thermodynamic processes in isolated systems is the one that increases entropy; they cannot proceed in the opposite direction.

It is worth noting that this is an important result, but it offers only the possibility of quantitative calculations for *equilibrium systems*. Therefore, we can say that the most important content of the second law from a thermodynamic point of view is the definition of entropy as a state function.

A3.4 *Third Law and the Uniqueness of the Entropy Scale*

As we have seen in Sect. 8.3, the uniqueness of the equilibrium constant of a chemical reaction is the consequence of the uniqueness of the entropy function [see (8.67)]. The third law announces this uniqueness. Historically, the first proposition was made by Nernst, in a “weak” form; namely, the entropy of change of phase transition of solid substances becomes smaller and smaller with decreasing temperature, and it goes to zero as temperature goes to 0 K. Planck gave a stronger form to this proposition a few years later. He concluded from quantum mechanical considerations that the degeneration in crystals should cease at 0 K as they only can have one equilibrium state; thus, the equilibrium entropy of all substances should be zero at 0 K.

Note that we know very little about the degeneracy of nuclei, but it does not change during thermodynamic processes at usual temperatures, including chemical reactions. Thus, it can be ignored in the calculation of entropy. It is also important to note that the nondegenerate state of crystals cannot always be achieved upon their cooling, as there is sometimes not enough energy available at the (rather low) temperature to the rearrangement of the crystal lattice. In these cases, there is a *residual entropy* which does not disappear even upon further cooling. However, the majority of substances do have zero entropy at zero temperature. This is the usual form of the **third law** of thermodynamics. It is worth noting that this is the only one of the four laws that is identical to one of the postulates (Postulate 4).

Further Reading

- Callen HB (1985) Thermodynamics and an introduction to thermostatistics, 2nd edn. Wiley, New York
- Carnot S (1824) Réflexions sur la puissance motrice du feu et sur les machines propres à développer cette puissance. Bachelier, Paris
- Carnot S, Thurston RH (ed. and trans.) (1890) Reflections on the motive power of heat and on machines fitted to develop that power [English translation], Wiley, New York
- Doggett B, Sutcliffe BT (1996) Mathematics for chemistry. Longman, Harlow
- Fraileigh JB (1990) Calculus with analytic geometry, 3rd edn. Addison Wesley, Reading, Massachusetts
- Lyons L (1995) All you wanted to know about mathematics but were afraid to ask: mathematics for science students. Cambridge University Press, Cambridge
- Thomas GB, Finney RL (1996) Calculus and analytic geometry, 9th edn. Addison Wesley, Reading, Massachusetts

Index

A

- Absolute activity, excess, 106
- Absolute temperature, 338
- Activation barrier, 210
- Activity, 101, 109–115
 - absolute, 101
 - coefficient, 109
 - referenced to Henry's law, 111
 - referenced to infinite dilution, 119
 - referenced to Raoult's law, 111
 - temperature and pressure
 - dependence of, 117
 - referenced to infinite dilution, 112
 - referenced to Raoult's law, 107
 - referenced to the pure substance, 107
 - relative, 101
 - with respect to (molar) concentration, 108
- Additivity, 11
- Adhesion, 237
- Adiabatic, 27
- Adiabatic, 6–8
 - process, 25
 - systems, 334
- Adjacent condensed phases, 234
- Affinity, 207
- Air conditioning, 77
- Alloys, 164
- Anode, 259
- Antiknocking, 85
- Antiporter, 317
- Apex, 186
- Avogadro constant, 3, 16, 265, 266
- Azeotropes, 156
 - maximum-boiling, 157
 - minimum-boiling, 157
- Azeotropic
 - composition, 156, 158
 - mixtures, 156

B

- Bifurcation, 167
- Bimolecular reaction, 302
- Binary electrolyte, 251
- Binary mixtures, 90, 147–154
 - ideal, 149
 - partially miscible, 162, 163
- Binodal curve, 162, 187
- Biochemistry, v
- Birdlime, 311
- Bivariate function, 319
- Boiling chips, 241
- Boiling point, 138
 - curve, 143, 151
 - surface, 187
- Boltzmann constant, 269
- Boltzmann factor, 293
- Bottom product, 192
- Braun, Karl Ferdinand, 225
- Bubble, 135, 236, 240
 - cap, 192
 - chamber, 135
 - valve, 192
- Bulk phases, 125

C

- Calcination of limestone, 216
- Callen, 2
- Caloric, 145
- Calorimetric measurements, 117, 218
- Canonical energy
 - statistical characterization of, 291
- Canonical ensemble, 274
- Canonical partition function, 278
- Capillary, 237
 - action, 238
 - depression, 238

- Capillary (*cont.*)
 rise, 237, 238
- Carbonic acid, formation of, 213
- Carnot
 cycle, 72, 336, 338
 engine, 72, 79
 heat pump, 76
 refrigerator, 76
- Carnot, Nicolas Léonard Sadi, 72, 332, 336
- Cathode, 259
- Cavity, 235
- Cell
 diagram, 254, 257, 258
 reaction, 256
 without transference, 263
- Central limit theorem, 293
- Chain rule, 20, 24, 56, 279, 322
 for partial derivatives, 323
- Changing a variable, 323
- Charge carrier, 241, 251
- Charged particles, 230
- Charge number, 242
 of the cell reaction, 256
- Charge transfer reaction, 258
- Chemical
 energy, 14
 equilibrium condition of, 39
 potential, 14, 38, 39, 50, 51, 58, 62, 89, 312
 in an electric field, 252
 of the electrolyte, 245
 excess, 105, 107, 117
 hypothetical, 107
 lowering of, 164
 of a pure substance, 64
 referred to one single particle, 286
 standard, 103, 104
 in terms of mole fractions, 106–108
 in terms of solute concentration,
 108–109
 reactions, 201
 work, 14
- Chromatographic techniques, 197
- Chromatographs, 316
- Clapeyron, Benoît Paul Émile, 143
- Clapeyron equation, 143, 197
- Classical thermodynamics, 331
- Clausius–Clapeyron equation, 144, 152, 197
- Clausius, Rudolf Julius Emmanuel, 144,
 332, 338
- Closed, 7
- Closely packed, 231
- Cloud chamber, 135
- Clouds, 241
- Cm^{-1} , as an energy unit, 305
- Coefficient
 of conductivity, 308
 of performance, 76, 80
 of a refrigerator, 75
 of thermal conductivity, 309
- Coexistence curve, 142
- Cogeneration, 75
- Cohesion, 237
- Colligative properties, 178, 181
- Combination without repetition, 272
- Common tangent, 172, 173
 line, 176
- Compatibility condition, 56
- Component, chemically independent, 126
- Composite
 functions, 322
 system, 9, 11
- Composition vector, 5
- Compressibility, 62, 146
 adiabatic, 128
 isothermal, 54, 67, 68, 128
 negative, 128
- Compression, 8
 factor, 58, 59
 ratio, 85
- Concave, 69, 127, 131, 161
- Concentration
 gradient, 311
 profile, 317
- Condensation trail, 135
- Condensed
 matter, 62
 systems, 63, 64
- Condition
 of chemical equilibrium, 203, 207
 of electric equilibrium, 253
 of electrochemical equilibria, 255
- Conditional probability, 275
- Conduction of heat, 309
- Conductive transport, 308
- Conductivity, 310
- Configuration space
 thermodynamic, 69
- Congruent
 freezing, 176, 200
 melting, 177
- Conjugate force, 316
- Conodes, 151, 170, 178, 187, 188
- Conservation of energy, 335
- Consistency condition, 23
- Constrained
 equilibrium, 255

systems, 6–8
 Container types, 7
 Contracting, 139
 Contrails, 241
 Conversion, 210
 Convex, 69, 127, 130, 159, 161, 207
 Convexity, 131
 condition of, 127
 Cooking, 185
 time, 183
 Cool-down rate, 318
 Cooling curves, 173, 198, 199
 Corresponding states
 principle of, 129
 Corrosion, 183
 Cotransport, 316
 Countercurrent, 192
 Coupled process, 316
 Critical compression coefficient, 61
 Critical isotherm, 129
 Critical molar volume, 61
 Critical point, 135, 137
 Critical pressure, 61, 130
 Critical temperature, 61, 147, 161, 162
 lower, 162, 163
 upper, 163
 Cryoscopic constant, 182
 α Crystal, 168
 β Crystal, 168
 Curie's theorem
 coupled processes, 317
 Current density, 308
 Curvature, 236
 of the concentration profile, 314
 Curved surfaces, 234
 Cyclic integral, 325
 Cyclic permutations, 324
 Cyclic process, 72
 Cyclic rule, 31, 81, 323

D

Dalton, John, 94
 Daltons law, 94
 Debye–Hückel
 constant, 250
 limiting law, 250
 theory, 264
 Debye, Peter Joseph Wilhelm, 250
 Decrease of the vapor pressure, 179
 Deep-freezer, 80
 Deformation, direction-dependent, 228
 Degeneracy, 288, 293

Degrees of freedom, 5
 Density of states, 293
 Depression of the freezing point, 180
 Deviation from ideality, 59
 negative, 155
 positive, 155
 Dew point
 curve, 150, 151
 surface, 187
 Diabatic, 7
 Diamagnetic, 228
 Diamond anvil cell (DAC), 223
 Diathermal, 7, 8, 33, 47
 Dice, 275
 Diesel cycle, 77
 Differential operator, 320
 Differentiation, 319
 implicit functions, 323
 rules of, 322
 Diffusion, 311
 coefficient, 312, 317
 potential, 262
 Dilate, 139
 Dilute solutions, 113, 118, 119
 Direction of the reaction, 206
 Discontinuity, 146
 Disorder, measure of, 298
 Dissipation, 71
 Dissolution of sugar in a cup of tea, 317
 Distillate, 192
 Distillation, 191
 fractional, 191, 192
 multistage, 192
 Distinguishable molecules, 285
 Distribution constant, 196
 Domestic heating, 77
 Drop, 240
 Droplet, 235
 Dufour effect, 316
 Dulong–Petit rule, 303

E

Ebullioscopic constant, 182
 Efficiency, 84, 337
 of the Carnot engine, 74
 Einstein solid, 269, 270, 303
 in canonical representation, 281
 Electric
 charge, 229
 conduction, 309
 conductivity, 309
 dipole moment, 229

- Electric (*cont.*)
 field, 229, 252
 heating, 77
 potential, 229
 difference, 253, 255
- Electrically charged systems, 229
- Electrochemical potential, 252
- Electrode, 259
 potential, 259
 reaction, 259
- Electrolyte, 246, 249
- Electrolytic cell, 254
- Electron conducting phase, 254
- Electroneutrality principle, 242, 244, 264
- Electronic
 degeneracy, 290
 partition function, 290
- Electronically excited state, 290
- Electrostatic interactions, 248
- Elementary charge, 241
- Elevation
 of the boiling point, 182
 of sublimation point, 182
- Endothermic reactions, 222, 225
- Energy
 conservation of, 8
 Energy distribution
 multiparticle, 293
 single particle, 294
 minimum of, 10, 30, 32
 per mole, 17
 per particle, 17
 recycling, 75
 zero point of, 13
- Enthalpy
 excess, 116
 function, 45
 minimum of, 46
 of mixing, 117, 218
- Entropy, 10, 11
 based thermal equation of state, 286
 calculation of, 53
 change
 of transitions, 220
 function, 10, 27, 57
 general statistical definition, 297
 maximum of, 10, 30, 32
 of mixing, 121
 molar, 11
 properties of, 10
 scale of, 15–17, 220
 as a state function, 341
 unit of, 16
 the zero of, 12
- Equation of state, 15, 17, 58
 empirical, 60
 entropy-based, 15
 mechanical, 19, 22
 thermal, 19, 23
 van der Waals, 60
- Equilibria at constant pressure, 44
- Equilibrium, 1, 4
 cell, 261
 chemical, 37, 50
 composition, 205
 conditions, 8–29, 32, 36, 38, 50–58
 of a multicomponent multiphase
 system, 170
 constant, 204, 304
 apparent, 212
 calculation of, 218
 concentration-independent, 212
 pressure dependence of, 221, 223
 reduced, 216
 temperature dependence of, 221
 in constant temperature and constant
 pressure systems, 48–50
 in constant temperature and constant
 volume systems, 46–48
 isentropic system, 36
 in isolated and isentropic systems, 29–41
 mechanical, 36, 50
 necessary condition of, 50
 states, 5, 10
 systems, 333
 thermal, 32–36, 41, 50
- Equipartition theorem, 296
- Ergodic hypothesis, 267, 275
- Ethanol–water mixture, 154
- Euler equation, 326
- Euler, Leonhard, 17
- Euler relation, 17–18, 252
 entropy-based, 18
- Euler theorem, 88
- Eutectic
 composition, 167, 172
 line, 167
 microcrystals, 174
 mixture, 165, 172
 points, 165, 198
 reaction, 168, 174
 solid, 165
 temperature, 167, 168
 three-phase, 189
- Eutectoid, 177
- Exact differential, 320

- Excess
 enthalpy, 122
 entropy, 116, 122
 Gibbs potential, 116, 122
 surface energy, 232, 234
 volume, 116
- Exothermic reactions, 222
- Expansion, 8, 70
 adiabatic, 71
 isenthalpic, 80
- Expectation value of energy, 279
- Expected values, 265
- Explicit functions, 323
- Extensive variables, 9
- Extent of reaction, 203, 210
- Extract, 195, 196
- Extremum, 39, 158
 principle, 9
- F**
- Factorial, 270
- Faraday constant, 242
- Faraday, Michael, 242
- Fick, Adolf Eugen, 312
- Fick's first law, 312
- Fick's second law, 314
- First law, 333, 335
- Flat surface, 237
- Flexible, 7
- Fluctuation, 135, 147, 292
- Flux, definition of, 308
- Fourier, Jean Baptiste Joseph, 309
- Fourier's law, 309, 318
- Franklin, Benjamin, 242
- Free energy, 47
 minimum of, 48
- Freezing point, 164
 curves, 165
- Freezing temperature, 164
- Friction, 71, 310
- Fugacity, 64, 66, 110
 coefficient, 65, 66, 104, 105
 partial, 104
- Function
 homogeneous first order, 11, 17
 homogeneous zero order, 12
- Fundamental equation, 10, 23, 27, 29, 40,
 45, 48, 49, 52, 57, 60, 66, 67,
 69, 107, 266, 278
 differential, 13, 15, 17
 of the Einstein solid, 271
 energy-based, 12, 19
 energy-based differential, 14
 entropy-based, 12, 19, 67
 extensive, 20
 G-based, 64
 intensive, 12, 21, 24
- G**
- Galvanic cell, 253
 silver-zinc, 254
- Galvani, Luigi, 253
- Gas
 electrodes, 261
 mixtures, 66
 monatomic, 19, 22, 24
- Gaussian function, 293
- General force, 307
- Geobarometers, 218
- Geometric series, 281, 289
- Gibbs–Duhem equation, 17–18, 20, 126, 156
- Gibbs energy, 49
- Gibbs function, 49
- Gibbs–Helmholtz equation, 117, 221, 331
- Gibbs, Josiah Willard, 2, 18
- Gibbs phase rule, 126, 136
- Gibbs potential, 49, 64
 excess, 117
 function, 89
 minimum of, 202
 as a function of the extent of reaction,
 209
 of mixing, 117, 209
 molar, 159
 partial molar, 115
- Glass capillary, 263
- Gradient, 307
- Gravitational field, 230
- Gravitational potential, 230
- H**
- Hagen–Poiseuille equation, 311
- Half cell, 259
- Harmonic oscillator, 269, 289
- Hauptsatz, 332
- Heat, 8, 25, 43
 absorbed, 13, 53, 74
 calculation of, 52
 capacity, 128, 146, 296
 at constant pressure, 53
 at constant volume, 22, 53, 67
 negative, 128
 at constant temperature, 52
 engines, 72, 73

- Heat (*cont.*)
 exchange, 26
 isobaric, 52
 pumps, 75
 domestic, 83
 of the reaction, 220
 rejected, 74
 reservoir, 73
 transfer, 32
 Height equivalent to one theoretical plate, 193
 Helmholtz, Hermann Ludwig Ferdinand, 47
 Henry's law, 154, 155
 Henry, William, 155
 Hesse, Ludwig Otto, 321
 Hessian matrix, 127, 321
 Heterogeneous
 reaction, 214
 system, 125
 Homogeneous function
 first-order, 326
 of order n , 325
 Homonuclear
 linear rotor, 289
 rotor, 305
 Hooke's law, 228
 Hückel, Erich Armand Joseph, 250
 Hydrodynamic flow, 70
 Hydrostatic
 equilibrium, 238
 pressure, 238
 Hyperbola, 149
 Hypertonic solution, 185
 Hypotonic solution, 185
- I**
 Ideal behavior, deviation from, 104
 Ideal binary mixtures, 160
 solid-liquid equilibrium, 158-159
 Ideal gas, 18, 21, 57, 59
 mixtures of, 93-95
 model, 22
 monatomic, 27, 39
 Ideality, 114
 Ideally, dilute solution, 119, 120
 Ideal mixture, 95, 102, 103, 111, 148
 hypothetical, 104
 Identical
 configurations, 289
 molecules, 279
 Immiscible, 160
 liquids, 125
 Imperfect crystal, 300
 Impermeable, 7
 Impossible process, 72
 Improper integral, 284
 Increments, 320
 Independent
 molecular modes, 281
 reactions, 206
 Infinite diffusion, 315
 one-dimensional, 316
 Inflection point, 163
 horizontal, 130, 131
 Inner potential, 253
 Instability, 135
 Integration constant, 20
 Intensive
 quantities, 50
 variables, 12
 Interface, 231
 layer, 230
 liquid-vapor, 232
 Internal combustion engines, 77
 Internal constraint
 release of, 29
 Internal energy, 5, 8, 13
 function, 12
 variance of, 291
 Inverse function, 323
 Inversion temperature, 82
 Ion-conducting phase, 254
 Ionic components, 243
 Ionic strength, 250, 251
 Ions, 230
 Irreversible process, 71, 72, 340
 Isenthalpic process, 81
 Isentropic, 46, 47
 system, 32, 35
 Isobar, 151
 Isolated, 7
 system, 32, 33
 Isothermal distillation, 241
 Isotherms, 131, 151, 170
- J**
 Joule, James Prescott, 80, 332, 334
 Joule-Thomson, 81
 coefficient, 81, 82
 effect, 80-85
- K**
 Kelvin equation, 240, 263
 Kelvin, Lord, 338
 Kinetic theory of gases, 265

L

Lambda (λ) transition, 146, 147
 Laminar flow, 310
 Latent heat, 145
 Law of corresponding states, 61
 Le Châtelier–Braun principle, 139, 225
 Le Châtelier, Henri Louis, 225
 Legendre transform, 279, 328
 Legendre transformation, 51
 partial, 326
 Lever rule, 140, 153, 162
 Lewis, Gilbert Newton, 104
 Limit
 at zero concentration, 108
 of zero pressure, 105
 Limiting value at zero pressure, 62, 63
 Linear rotor, 288, 295
 Linear structure, 297
 Linear transport equations, 307, 308
 Liquefaction, 82
 Liquid, metastable, 135
 Liquid curve, 150
 Liquid junction potential, 262, 263
 Liquid–liquid extraction, 195
 Liquidus
 curves, 165, 167
 surface, 188
 Liquid–vapor equilibrium, 78, 131
 Liquid–vapor phase diagram, 150
 Local equilibrium, 307
 Locally stable states, 162

M

Magnetic field, 228
 Magnetic induction, 229
 Magnetic interactions, 228
 Magnetic moment, 229
 Magnetization vector, 228
 Manostat, 43, 44, 48
 Mass fraction, 120
 Massieu, François Jacques Dominique, 329
 Massieu function, 279, 329
 Material balance equation, 312
 Material sciences, v
 Maximum, 39, 158
 principle, 267
 work, 70
 Maxwell
 construction., 133
 relations, 55, 321, 322
 Mean absolute activity, 247
 Mean activity, 248, 249
 coefficient, 251
 Mean chemical potential, 248
 Mean relative activity, 248
 Measurable quantities, 53, 54, 58, 81
 Mechanical dispersion, 160, 170
 Mechanical work, 72
 Melting point, 138, 139, 166
 curve, 143
 Membrane permeability
 regulation of, 185
 Meniscus, 238
 Metallurgy, 190
 Metastable state, 6
 Method of intercepts, 92
 Microcanonical
 ensemble, 266
 entropy, 297
 partition function, 268
 Microcrystals, 169
 Microstates, 266
 Mineralogy, 190
 Minerals, formation of, 218
 Minimum, 39, 158
 boiling azeotrope, 193
 of Gibbs potential, 224
 Miscibility, 126, 158, 165
 limited, 161, 168
 limit of, 162
 partial, 169, 171, 172
 unlimited, 111, 162, 163, 169,
 171, 172
 Mixed crystals, 158
 Mixing, 96
 dilute solutions, 99
 entropy of, 97
 free energy of, 98
 Gibbs potential of, 96
 internal energy of, 97
 volume of, 97
 Mixture crystal, 167
 Mixtures, 87–122
 Molar
 enthalpy of fusion, 166
 entropy, 63, 137, 303
 free energy, 301
 expansion of, 60
 Gibbs potential, 160, 166, 170
 heat capacity, 271, 303
 internal energy, 303
 partition function, 302
 quantity, 11
 volume, 137
 Molar Gibbs potential of fusion, 166

- Molecular dynamic simulations, 302
 Molecular modes, 294
 Molecular partition function, 281
 standard, 302, 304
 Molecular surroundings, 118
 Molecular translational partition
 function, 284, 285
 Molecular vibration, 295
 Mole fractions, 11, 89
 Moment of inertia, 287
 Momentum transfer, 310
 Monatomic
 gases, 285
 ideal gas, 285, 287
 molecules, 297
 Monotectic
 line, 177
 reaction, 174, 176
 Monotectoid, 177
 Multiatomic molecule, 288
 Multivariate
 calculus, 319
 functions
 differentiation, 319
 integration of, 324
- N**
- Nernst equation, 258
 Nernst, Walter Hermann, 333, 341
 Newtonian fluid, 311
 Newton, Isaac, 311
 Newton's law, 311
 Nodes, 151, 162, 170
 Nonequilibrium
 changes, 333
 states, 5
 Nonideality, 168
 Nonlinear multiatomic molecule, 290
 Non-simple systems, 227
 Nonvolatile, 215
 No-phase area, 167, 170, 174, 177, 187–189
 No-phase region, 150
 Normal vibrational modes, 290
 Nuclear modes, 283
 Number of degrees of freedom, 11, 89, 126,
 167, 231
 Number of theoretical plates, 193
N, V, E ensemble, 266
N, V, T ensemble, 274
- O**
- Ohm, Georg Simon, 309
 Ohm's law, 309
 Onsager's reciprocity relationships, 317
 Open, 7
 Osmometer, 184
 Osmosis, 179, 183
 Osmotic pressure, 184
 Otto cycle, 77
 air-standard, 83
 Outer potential, 253
 Overall composition, 151
 Oversaturated, 241
 Oxidation, 257, 260
- P**
- Packed column, 193
 Paramagnetic, 228
 Partial derivative, 319
 Partially miscible binary mixtures, 159–185
 Partial miscibility, 174, 189
 Partial molar enthalpy, standard, 218
 Partial molar entropy, standard, 218
 Partial molar quantities, 87–93
 Partial molar volumes, 91, 92, 120
 Partial pressures, 94, 103, 148, 214
 Particle in a box, 283
 Partition ratio, 196
 Parts per billion, 243
 Pascal's law, 228
 Peltier effect, 316
 Peritectic
 line, 175
 reaction, 175
 Peritectoid, 177
 Permeable, 7
 Permutation, 270
 without repetition, 285
 Phase, 125
 diagrams
 Cd–Bi, 165
 liquid–liquid, 161–163
 P–T, 141
 of pure substances, 135–139
 solid–liquid, 163–178
 equilibria
 of pure substances, 129–135
 rule, 150, 178
 separation, 129, 159, 163
 transition
 continuous, 146
 first-order, 146
 second-order, 146
 Physical chemistry, 1
 Planck function, 329
 Planck, Max, 333, 341

- Planck's constant, 270
 Plimsoll sign, 101
 Poincaré, Jules Henri, 332
 Poise, 311
 Poiseuille, Jean Louis Marie, 311
 Pollution, 183
 Polynomial, 59
 Porous diffusion, 179
 Postulate
 first, 4
 postulate 1, 5, 8, 54, 69, 227
 postulate 2, 10, 50, 69, 267
 postulate 3, 11, 12, 16, 32
 postulate 4, 12, 16, 21, 28, 55, 220, 300, 341
 Potential
 of the cell reaction, 256, 258
 difference of a galvanic cell, 256
 functions, 52
 energy-like, 50–58
 Power plants, 74
 Power series, 59, 277
 Practical activity, 108
 coefficient, 108
 Preparing dishes, 183
 Pressure, 7, 14
 Primary crystals, 174
 Principal radii of curvature, 237
 Principle process, 316
 Probability density
 function, 277
 of the states of the canonical ensemble, 279
 Probability distribution, 265
 function, 267, 269
 Projections, 135, 186, 189
 P–T plane, 141
 P–V diagram, 73
 P–V–T diagram, 135, 136, 139
 Pycnometer, 120
- Q**
- Quantum chemical methods, 302
 Quasistatic
 changes, 333
 heat, 340
 process, 70, 72, 339, 340
- R**
- Radial charge density, 264
 Raffinate, 195, 196
 Random fluctuations, 267
 Rankine cycle, 77, 79
 Rankine engine, 79
 Rankine, William John Macquorn, 77
 Raoult, François-Marie, 148
 Raoult's law, 148, 150, 198
 nonideal equivalent of, 154
 Rate of change, 313
 Rational activity, 107, 110, 211
 Reacting species, 201
 Reaction entropy, 226
 Reaction standard Gibbs potential, 213,
 219, 301
 calculation of, 218
 Reaction standard volume, 223
 Real binary mixtures, 161
 liquid–vapor equilibrium of, 154–157
 Real gas, 22, 59
 chemical potential and fugacity of, 64–68
 Real mixtures, 103, 115
 Recrystallizations, 173, 193
 Rectification, 192
 Reduced pressure, 130
 Reduced temperature, 130
 Reduced variables, 61
 Reduced volume, 130
 Reduction, 257, 260
 Reference pressure, 102
 Reference state, 13, 21, 95, 101, 102
 Reflux, 192
 Refrigerators, 75
 domestic, 80
 Relative activity, 106, 107, 110, 211
 coefficient, 106, 107
 Relative fluctuation, 292
 Relaxation time, 70
 Reservoir, 44, 46, 48, 275
 Residual entropy, 300, 341
 Resistance, 310
 Reverse osmosis, 185
 Reversible process, 71, 72
 Rigid, 7
 Rotating axle, 73
 Rotational
 constant, 287
 partition function, 287, 288, 305
 quantum number, 288
 symmetry factor, 289
 Rule of common tangents, 162
- S**
- Sackur, Otto, 287
 Sackur–Tetrode equation, 27, 28, 287
 Salt
 bridge, 263

- Salt (*cont.*)
 dissolved in water, 164
- Saturated vapor, 79
- Scalar quantities, 228
- Schrödinger equation, 289
- Secondary crystals, 173
- Second law, 333, 340
- Second-order differential, 321
- Second partial derivatives, 320
- Section, 152
- Semi-infinite diffusion, 314
- Semipermeable, 7, 37, 179
- Separation funnel, 197
- Separation of mixtures, 190
- Settling vessel, 196
- Shock waves, 70
- Simple system, 4
- Simultaneous chemical reactions, 206
- Single component system, 64
- Single-particle energy, 294
- Sliding, 139
- Snow removal, 183
- Solid solutions, 158, 173
- Solidus
 curves, 168, 175
 surfaces, 188
- Solubility, 118
- Solute, 113
- Solvated species, 119
- Solvation shell, 250
- Solvent, 113
 shell, 118
- Solvus
 curve, 175
 surfaces, 188
- Sommerfeld, v
- Spectroscopic data, 302
- Spontaneous, 71
- Stability
 criterion of, 224
 global, 161
 local, 161, 163
 of phases, 127–129, 131
 range, 188
 regions, 150
- Stability conditions, 50, 128
 global, 134
 local, 134
- Stable
 globally, 135
 locally, 134
- Standard chemical potential, 107, 110
 referenced to infinite dilution, 119
- Standard concentration, 102
- Standard electrode potential, 260
- Standard enthalpies, 219
 of formation, 220
- Standard Gaussian, 315
- Standard heat of formation, 219
- Standard hydrogen electrode, 261
- Standard molality, 102
- Standard potential, 257–259
- Standard pressure, 102, 212
- Standard reaction enthalpy, 225
- Standard reaction Gibbs potential, 204, 209,
 210, 258
- Standard solvent, 115
- Standard states, 103, 105, 109–115
 choice of, 211
 hypothetical, 108, 109
- State functions, 5, 32, 66, 320, 324, 338
 existence of, 335
- State surface, 30, 69, 135
- State variables, 5, 323
- Static, 69
- Statistical, 61
 mechanics, 265
 physics, 265
 thermodynamics, 265
- Steam distillation, 194
- Steam engines, 332
- Steam turbines, 332
- Stirling formula, 270, 272, 286, 300
- Stoichiometric
 equation, 201, 202
 matrix, 206
 numbers, 201, 212
- Stress, 228
- Sublimation, 138
 point curve, 143
- Supercooled liquid, 299
- Superheated liquid, 162
- Superheating, 79, 241
- Supersaturated vapor, 162, 241
- Surface layer, 231
- Surface tension, 230, 232, 263
 thermodynamic definition, 233
- Surroundings, 333
- Symporter, 317
- Syntectic line, 177
- Syntectic reaction, 174, 177
- System, constant pressure, 43–46
- T**
- Tangent lines, 162
- Tangent planes, 127

- Taylor series, 59
 - T-x phase diagram, 153
 - ternary, 186
 - tridimensional, 186
 - Temperature, 12, 14, 34
 - Celsius scale, 15
 - Fahrenheit scale, 16
 - gradient, 318
 - kelvin scale, 16
 - scale, 15–17
 - Tensor, 228
 - Terminal
 - metal, 254
 - wires, 254
 - Ternary
 - eutectics, 190
 - mixture, 185
 - Tetrode, Hugo Martin, 287
 - Textures, 167, 174
 - Thermal diffusion, 316
 - Thermal energy, 72
 - Thermal equilibrium, 34, 333
 - Thermal expansion, coefficient of, 53, 67, 68, 82
 - Thermally conductive rod, 317
 - Thermal wavelength, 285
 - Thermodynamic(s), 1, 3, 61, v
 - chemical, 2, 87
 - efficiency, 73
 - phenomenological, 3
 - postulates, v
 - postulational, 4
 - postulatory approach, v
 - potentials, 50, 57
 - quantities
 - calculation of, 57–58
 - statistical, 3, 265
 - systems, 4, 6
 - tables, 103
 - Thermoelectric effect, 316
 - Thermostat, 43, 46, 48
 - Third law, 333, 341
 - Thomson, William, 338
 - Throttle, 80, 81
 - Throttling, 82
 - valve, 80
 - Tie line, 151, 178, 188
 - Tisza, 2
 - Top product, 192
 - Total differential, 320
 - Total pressure, 94
 - Total vibrational partition function, 289
 - Transition state theory, 302
 - Transition temperature, 147
 - Translational partition function, 283
 - Transport equation, one-dimensional, 308
 - Transport phenomena, 307
 - Triangular diagram, 186
 - Triple line, 136
 - Triple point, 136, 138, 167, 172
 - of methanol, 197
 - Triple product rule, 323
 - T-S diagram, 73, 78, 79
 - Turbulence, 71
 - Two-phase region, 151
 - Two-state molecules
 - in canonical representation, 281
 - in microcanonical representation, 272
- U**
- Unimolecular reaction, 302
 - Unstable, 161
 - locally, 132
- V**
- van der Waals
 - equation, 61
 - equation of state, 22
 - reduced, 130
 - fluid, 22–28, 129
 - van der Waals, Johannes Diderik, 22
 - van't Hoff, 225
 - equation, 184, 222, 226
 - Vapor, 135
 - curve, 150
 - metastable, 135
 - pressure
 - curve, 150
 - saturated, 150
 - total, 148
 - quality, 140, 141
 - supersaturated, 135
 - Vector variables, 228
 - Velocity
 - gradient, 311
 - of sound, 70
 - Vibrational
 - degrees of freedom, 290
 - energy quantum, 270
 - modes, 269
 - partition function, 289, 305
 - quantum number, 289
 - Virial coefficient, 60
 - Virial equation, 59–61

Viscosity, 70
Viscous flow, 310
Volume, 58
 of mixing, 116
 work, 7, 71

W

Waste heat, 75
Watt, James, 332
Wavenumber, 305
Weightlessness, 235
Wetting, 235, 237
Wine, 6
Work, 8, 25, 26
 adiabatic, 52
 calculation of, 52

 constant pressure, 52
 gained, 74
 mechanical, 7
 volume, 43

Y

Young–Laplace equation, 237
Young’s theorem, 55, 321

Z

Zero-point energy of the reaction, 302
Zeroth law, 333
Zone melting, 193
Zustandsumme, 278