

**CHAPTER 1
PRINCIPLES OF CELLULAR
TELECOMMUNICATIONS**

**CHAPTER 2
FEATURES OF GSM**

**CHAPTER 3
GSM NETWORK
COMPONENTS**

**CHAPTER 4
GSM TERRESTRIAL
INTERFACES**

**CHAPTER 5
CHANNELS ON THE AIR
INTERFACE**



**CHAPTER 6
CHANNELS ON THE AIR
INTERFACE**

**CHAPTER 7
RADIO INTERFACE
OPTIMIZATION**

**CHAPTER 8
INTRODUCTION TO
MICROCELLULAR**

CP02 EXERCISE

APPENDIX 1







MOTOROLA

Cellular Infrastructure Group

ISSUE 5 REVISION 4

CP02

INTRODUCTION TO DIGITAL CELLULAR

GSM

GLOBAL SYSTEM FOR
MOBILE COMMUNICATIONS

FOR TRAINING PURPOSES ONLY



MOTOROLA

**ISSUE 5
REVISION 4**

**CP02
INTRODUCTION TO
DIGITAL CELLULAR**

**FOR TRAINING
PURPOSES ONLY**

CP02
INTRODUCTION TO DIGITAL
CELLULAR





ISSUE 5 REVISION 4

CP02 Introduction to Digital Cellular

© Motorola 1993, 1994, 1995, 1996, 1997, 1998
All Rights Reserved
Printed in the U.K.

Copyrights, notices and trademarks

Copyrights

The Motorola products described in this document may include copyrighted Motorola computer programs stored in semiconductor memories or other media. Laws in the United States and other countries preserve for Motorola certain exclusive rights for copyright computer programs, including the exclusive right to copy or reproduce in any form the copyright computer program. Accordingly, any copyright Motorola computer programs contained in the Motorola products described in this document may not be copied or reproduced in any manner without the express written permission of Motorola. Furthermore, the purchase of Motorola products shall not be deemed to grant either directly or by implication, estoppel or otherwise, any license under the copyrights, patents or patent applications of Motorola, except for the rights that arise by operation of law in the sale of a product.

Restrictions

The software described in this document is the property of Motorola. It is furnished under a license agreement and may be used and/or disclosed only in accordance with the terms of the agreement. Software and documentation are copyright materials. Making unauthorized copies is prohibited by law. No part of the software or documentation may be reproduced, transmitted, transcribed, stored in a retrieval system, or translated into any language or computer language, in any form or by any means, without prior written permission of Motorola.

Accuracy

While reasonable efforts have been made to assure the accuracy of this document, Motorola assumes no liability resulting from any inaccuracies or omissions in this document, or from the use of the information obtained herein. Motorola reserves the right to make changes to any products described herein to improve reliability, function, or design, and reserves the right to revise this document and to make changes from time to time in content hereof with no obligation to notify any person of revisions or changes. Motorola does not assume any liability arising out of the application or use of any product or circuit described herein; neither does it convey license under its patent rights of others.

Trademarks



and **MOTOROLA** are trademarks of Motorola Inc.

UNIX is a registered trademark in the United States and other countries, licensed exclusively through X/Open Company Limited.

Tandem, **Integrity**, **Integrity S2**, and **Non-Stop-UX** are trademarks of Tandem Computers Incorporated.

X Window System, **X** and **X11** are trademarks of the Massachusetts Institute of Technology.

Looking Glass is a registered trademark of Visix Software Ltd.

OSF/Motif is a trademark of the Open Software Foundation.

Ethernet is a trademark of the Xerox Corporation.

Wingz is a trademark and **INFORMIX** is a registered trademark of Informix Software Ltd.

SUN, **SPARC**, and **SPARCStation** are trademarks of Sun Microsystems Computer Corporation.

IBM is a registered trademark of International Business Machines Corporation.

HP is a registered trademark of Hewlett Packard Inc.

General information	1
Important notice	1
Purpose	1
About this manual	1
Cross references	2
Text conventions	2
First aid in case of electric shock	3
Warning	3
Artificial respiration	3
Burns treatment	3
Reporting safety issues	4
Introduction	4
Procedure	4
Warnings and cautions	5
Introduction	5
Warnings	5
Cautions	5
General warnings	6
Introduction	6
Warning labels	6
Specific warnings	6
High voltage	6
RF radiation	6
Laser radiation	6
Lifting equipment	7
Do not	7
Battery supplies	7
Toxic material	7
Human exposure to radio frequency energy (PCS1900 only)	8
Introduction	8
Definitions	8
Maximum permitted exposures	8
Maximum permitted exposure ceilings	9
Example calculation	10
Power density measurements	10
Other equipment	10
Beryllium health and safety precautions	11
Introduction	11
Health issues	11
Inhalation	11
Skin contact	12
Eye contact	12
Handling procedures	12
Disposal methods	12
Product life cycle implications	12
General cautions	13
Introduction	13
Caution labels	13
Specific cautions	13
Fibre optics	13
Static discharge	13

Devices sensitive to static	14
Introduction	14
Special handling techniques	14
Motorola GSM manual set	15
Introduction	15
Generic manuals	15
Tandem OMC	15
Scaleable OMC	16
Related manuals	16
Service manuals	16
Category number	17
Catalogue number	17
Ordering manuals	17
Chapter 1	
Principles of Cellular Telecommunications	i
Principles of Cellular Telecommunications	1-1
Objectives	1-1
Overview	1-2
Advantages of Cellular Communications	1-2
Network Components	1-4
Frequency Spectrum	1-6
Introduction	1-6
Cell Size	1-8
Large Cells	1-8
Small Cells	1-8
The Trade Off – Large vs Small	1-8
Frequency Re-use	1-10
Co-channel Interference	1-10
Adjacent Channel Interference	1-10
Sectorization	1-12
Using Sectored Sites	1-14
4 Site/3 Cell	1-14
Switching and Control	1-16
Chapter 2	
Features of GSM	i
Features of GSM	2-1
Section Objectives	2-1
Compatibility	2-2
Noise Robust	2-4
Flexibility and Increased Capacity	2-6
Use of Standardised Open Interfaces	2-8
Improved Security and Confidentiality	2-10
Flexible Handover Processes	2-12
ISDN Compatibility	2-14
2B+D	2-14

Enhanced Range Of Services	2-16
Speech Services	2-18
Telephony	2-18
Emergency Calls (with/without SIM Card inserted in MS)	2-18
Short Message Service Point To Point	2-18
Short Message Cell Broadcast	2-18
Advanced Message Handling Service	2-18
Dual Personal and Business Numbers	2-18
Data Services	2-20
Supplementary Services	2-22

Chapter 3**GSM Network Components** **i**

GSM Network Components	3-1
Section Objectives	3-1
GSM Network Overview	3-2
Mobile Station (MS)	3-4
Mobile Equipment (ME)	3-6
Subscriber Identity Module (SIM)	3-8
Base Station System (BSS)	3-10
Base Station Controller (BSC)	3-12
Base Transceiver Station – BTS	3-12
BSS Configurations	3-14
Transcoder (XCDR)	3-16
Network Switching System	3-18
Mobile Services Switching Centre (MSC)	3-20
Home Location Register (HLR)	3-22
Visitor Location Register (VLR)	3-24
Location Area Identity	3-24
Temporary Mobile Subscriber Identity	3-24
Mobile Subscriber Roaming Number	3-24
Equipment Identity Register (EIR)	3-26
Authentication Centre (AUC)	3-28
Authentication Process	3-28
Interworking Function (IWF)	3-30
Echo Canceller (EC)	3-32
Operations and Maintenance System	3-34
Overview	3-34
Network Management Centre (NMC)	3-34
Operations and Maintenance Centre (OMC)	3-34
Network Management Centre (NMC)	3-36
Operations and Maintenance Centre (OMC)	3-38
The Network In Reality	3-40

Chapter 4**GSM Terrestrial Interfaces** **i**

GSM Terrestrial Interfaces	4-1
Section Objectives	4-1

Introduction	4-2
2 Mbit/s Trunk 30-channel PCM	4-4
X.25 Interfaces	4-6
ITU-TS Signalling System #7	4-8
A-bis (LAPD) Interfaces	4-10
Interconnections	4-12
Interface Names	4-14
Chapter 5	
Channels on the Air Interface	i
Channels on the Air Interface	5-1
Section Objectives	5-1
Transmission of Analogue and Digital Signals	5-2
Modulation Techniques	5-2
Transmission of Digital Signals	5-4
Phase Shift Keying (PSK)	5-4
Gaussian Minimum Shift Keying (GMSK)	5-4
Physical and Logical Channels	5-6
GSM Physical Channels	5-6
GSM Logical Channels	5-8
Traffic Channels (TCH)	5-8
GSM Control Channel Groups	5-10
BCCH Group	5-10
CCCH Group	5-10
DCCH Group	5-10
GSM Logical Channels	5-12
Control Channels	5-12
Channel Combinations	5-18
Channel Combinations and Timeslots	5-18
Multiframes and Timing	5-20
The 26-frame Traffic Channel Multiframe	5-20
The 51-frame Control Channel Multiframe	5-22
The 51-frame Control Channel Multiframe (BCCH/CCCH)	5-24
The 51-frame Control Channel Multiframe – DCCH/8 (SDCCH and SACCH) ..	5-26
The 51-frame Control Channel Multiframe – Combined Structure	5-28
Superframes and Hyperframes	5-30
Mobile Activity – Transmit and Receive Timeslots	5-32
Overview	5-32
GSM Basic Call Sequence	5-34
Chapter 6	
Channels on the Air Interface	i
Channel Coding on the Air Interface	6-1
Section Objectives	6-1
GSM Bursts	6-2
Burst Types	6-4

Error Protection and Detection	6-6
Speech Channel Encoding	6-8
Channel Coding for Enhanced Full Rate	6-10
Overview	6-10
Preliminary Channel Coding for EFR	6-10
Error Protection and Detection	6-12
Control Channel Encoding	6-12
Data Channel Encoding	6-14
Mapping Logical Channels onto the TDMA Frame Structure	6-16
Interleaving	6-16
Diagonal Interleaving – Speech	6-18
Transmission – Speech	6-20
Rectangular Interleaving – Control	6-22
Transmission – Control	6-22
Diagonal Interleaving – Data	6-24
Transmission – Data	6-24
Chapter 7	
Radio Interface Optimization	i
Radio Interface Optimization	7-1
Section Objectives	7-1
Transmission Timing	7-2
Battery Life	7-4
Introduction	7-4
Power Control	7-4
Voice Activity Detection (VAD)	7-6
Overview	7-6
Discontinuous Transmission (DTX)	7-6
Discontinuous Reception (DRX)	7-8
Multipath Fading	7-10
Equalization	7-12
Diversity	7-14
Frequency Hopping	7-16
Introduction	7-16
Chapter 8	
Introduction to Microcellular	i
Introduction to Microcellular	8-1
Section Objectives	8-1
Introduction	8-2
What is Microcell?	8-2
Why Deploy Microcells?	8-2
How are Microcells Deployed?	8-4
Building Penetration from Externally Mounted Cells	8-6
Antenna Types	8-8
Directional Antennas	8-8
Omni Antennas	8-8

The Microcellular Solution	8-10
Picocells	8-12
CP02 Exercise	8-i
Exercise	8-ii
Notes Page	8-viii
Appendix 1 (GSM History & Organization)	App 1-1
GSM History	App 1-2
Frequency Band Reserved for Cellular (1979)	App 1-2
"Groupe Special Mobile" Created Within CEPT (1982)	App 1-2
"Permanent Nucleus" Established (1986)	App 1-2
ETSI takes over GSM (1988)	App 1-2
Phase 1 GSM Recommendations Frozen (1990)	App 1-2
GSM Changes to SMG (1991/1992)	App 1-4
GSM is launched (1992)	App 1-4
Phase 2 GSM Technical Specifications Frozen (1993)	App 1-4
GSM Coverage	App 1-4
SMG Subsidiary Bodies	App 1-6
Overview	App 1-6
The Technical Specifications	App 1-6
GSM History & Organisation	App 1-8
The GSM Memorandum of Understanding (MoU)	App 1-8
GSM Coverage	App 1-10
Appendix 2 (Call & Handover Sequences)	App 2-1
GSM Basic Call Sequence	App 2-2
Mobile to Land Sequence	App 2-4
Land to Mobile Sequence	App 2-6
MS Initiated Call Clearing Sequence	App 2-10
Inter-BSS Handover Sequence	App 2-12
Location Update Sequence	App 2-14
Authentication and Ciphering	App 2-16
Equipment Identification	App 2-18
Glossary of technical terms and abbreviations	G-1
Numbers	G-2
A	G-2
B	G-4
C	G-6
D	G-10
E	G-13
F	G-14
G	G-16
H	G-17

I	G-18
K	G-20
L	G-20
M	G-21
N	G-25
O	G-26
P	G-27
Q	G-29
R	G-30
S	G-32
T	G-36
U	G-38
V	G-39
W	G-40
X	G-40
Z	G-40

General information

Important notice

If this manual was obtained when you attended a Motorola training course, it will not be updated or amended by Motorola. It is intended for TRAINING PURPOSES ONLY. If it was supplied under normal operational circumstances, to support a major software release, then corrections will be supplied automatically by Motorola in the form of General Manual Revisions (GMRs).

Purpose

Motorola Global System for Mobile Communications (GSM) Technical Education manuals are intended to support the delivery of Technical Education only and are not intended to replace the use of Customer Product Documentation.

WARNING

Failure to comply with Motorola's operation, installation and maintenance instructions may, in exceptional circumstances, lead to serious injury or death.

These manuals are not intended to replace the system and equipment training offered by Motorola, although they can be used to supplement and enhance the knowledge gained through such training.

About this manual

The manual contains ...

AUTHOR NOTE:

Authors must complete the above. You should contact the appropriate Trainer, if this manual is used with DBT, to include any course objectives.

Cross references

Throughout this manual, cross references are made to the chapter numbers and section names. The section name cross references are printed bold in text.

This manual is divided into uniquely identified and numbered chapters that, in turn, are divided into sections. Sections are not numbered, but are individually named at the top of each page, and are listed in the table of contents.

Text conventions

The following conventions are used in the Motorola GSM manuals to represent keyboard input text, screen output text and special key sequences.

Input

Characters typed in at the keyboard are shown like this.

Output

Messages, prompts, file listings, directories, utilities, and environmental variables that appear on the screen are shown like this.

Special key sequences

Special key sequences are represented as follows:

CTRL-c	Press the Control and c keys at the same time.
ALT-f	Press the Alt and f keys at the same time.
	Press the pipe symbol key.
CR or RETURN	Press the Return (Enter) key. The Return key is identified with the ↵ symbol on both the X terminal and the SPARCstation keyboards. The SPARCstation keyboard Return key is also identified with the word Return.

First aid in case of electric shock

Warning

WARNING

Do not touch the victim with your bare hands until the electric circuit is broken.

Switch off. If this is not possible, **protect yourself** with dry insulating material and pull or push the victim clear of the conductor.

Artificial respiration

In the event of an electric shock it may be necessary to carry out artificial respiration. Send for medical assistance immediately.

Burns treatment

If the patient is also suffering from burns, then, without hindrance to artificial respiration, carry out the following:

1. **Do not attempt to remove clothing adhering to the burn.**
2. If help is available, or as soon as artificial respiration is no longer required, cover the wound with a **dry** dressing.
3. Do **not** apply oil or grease in any form.

Reporting safety issues

Introduction

Whenever a safety issue arises, carry out the following procedure in all instances. Ensure that all site personnel are familiar with this procedure.

Procedure

Whenever a safety issue arises:

1. Make the equipment concerned safe, for example, by removing power.
2. Make no further attempt to tamper with the equipment.
3. Report the problem directly to GSM MCSC +44 (0)1793 430040 (telephone) and follow up with a written report by fax +44 (0)1793 430987 (fax).
4. Collect evidence from the equipment under the guidance of the MCSC.

Warnings and cautions

Introduction

The following describes how warnings and cautions are used in this manual and in all manuals of the Motorola GSM manual set.

Warnings

Definition

A warning is used to alert the reader to possible hazards that could cause loss of life, physical injury, or ill health. This includes hazards introduced during maintenance, for example, the use of adhesives and solvents, as well as those inherent in the equipment.

Example and format

WARNING

Do not look directly into fibre optic cables or optical data in/out connectors. Laser radiation can come from either the data in/out connectors or unterminated fibre optic cables connected to data in/out connectors.

Cautions

Definition

A caution means that there is a possibility of damage to systems, or individual items of equipment within a system. However, this presents no danger to personnel.

Example and format

CAUTION

Do not use test equipment that is beyond its calibration due date when testing Motorola base stations.

General warnings

Introduction

Observe the following warnings during all phases of operation, installation and maintenance of the equipment described in the Motorola GSM manuals. Failure to comply with these warnings, or with specific warnings elsewhere in the Motorola GSM manuals, violates safety standards of design, manufacture and intended use of the equipment. Motorola assumes no liability for the customer's failure to comply with these requirements.

Warning labels

Personnel working with or operating Motorola equipment must comply with any warning labels fitted to the equipment. Warning labels must not be removed, painted over or obscured in any way.

Specific warnings

Warnings particularly applicable to the equipment are positioned on the equipment and within the text of this manual. These must be observed by all personnel at all times when working with the equipment, as must any other warnings given in text, on the illustrations and on the equipment.

High voltage

Certain Motorola equipment operates from a dangerous high voltage of 230 V ac single phase or 415 V ac three phase mains which is potentially lethal. Therefore, the areas where the ac mains power is present must not be approached until the warnings and cautions in the text and on the equipment have been complied with.

To achieve isolation of the equipment from the ac supply, the mains input isolator must be set to off and locked.

Within the United Kingdom (UK) regard must be paid to the requirements of the Electricity at Work Regulations 1989. There may also be specific country legislation which need to be complied with, depending on where the equipment is used.

RF radiation

High RF potentials and electromagnetic fields are present in the base station equipment when in operation. Ensure that all transmitters are switched off when any antenna connections have to be changed. Do not key transmitters connected to unterminated cavities or feeders.

Refer to the following standards:

- ANSI IEEE C95.1-1991, *IEEE Standard for Safety Levels with Respect to Human Exposure to Radio Frequency Electromagnetic Fields, 3kHz to 300GHz.*
- CENELEC 95 ENV 50166-2, *Human Exposure to Electromagnetic Fields High Frequency (10kHz to 300GHz).*

Laser radiation

Do not look directly into fibre optic cables or optical data in/out connectors. Laser radiation can come from either the data in/out connectors or unterminated fibre optic cables connected to data in/out connectors.

Lifting equipment

When dismantling heavy assemblies, or removing or replacing equipment, the competent responsible person must ensure that adequate lifting facilities are available. Where provided, lifting frames must be used for these operations. When equipments have to be manhandled, reference must be made to the Manual Handling of Loads Regulations 1992 (UK) or to the relevant manual handling of loads legislation for the country in which the equipment is used.

Do not ...

... substitute parts or modify equipment.

Because of the danger of introducing additional hazards, do not install substitute parts or perform any unauthorized modification of equipment. Contact Motorola if in doubt to ensure that safety features are maintained.

Battery supplies

Do not wear earth straps when working with standby battery supplies.

Toxic material

Certain Motorola equipment incorporates components containing the highly toxic material Beryllium or its oxide Beryllia or both. These materials are especially hazardous if:

- Beryllium materials are absorbed into the body tissues through the skin, mouth, or a wound.
- The dust created by breakage of Beryllia is inhaled.
- Toxic fumes are inhaled from Beryllium or Beryllia involved in a fire.

See the **Beryllium health and safety precautions** section for further information.

Human exposure to radio frequency energy (PCS1900 only)

Introduction

This equipment is designed to generate and radiate radio frequency (RF) energy. It should be installed and maintained only by trained technicians. Licensees of the Federal Communications Commission (FCC) using this equipment are responsible for insuring that its installation and operation comply with FCC regulations designed to limit human exposure to RF radiation in accordance with the American National Standards Institute IEEE Standard C95.1-1991, *IEEE Standard for Safety Levels with Respect to Human Exposure to Radio Frequency Electromagnetic Fields, 3kHz to 300GHz*.

Definitions

This standard establishes two sets of maximum permitted exposure limits, one for **controlled** environments and another, that allows less exposure, for **uncontrolled** environments. These terms are defined by the standard, as follows:

Uncontrolled environment

Uncontrolled environments are locations where there is the exposure of individuals who have no knowledge or control of their exposure. The exposures may occur in living quarters or workplaces where there are no expectations that the exposure levels may exceed those shown for uncontrolled environments in the table of maximum permitted exposure ceilings.

Controlled environment

Controlled environments are locations where there is exposure that may be incurred by persons who are aware of the potential for exposure as a concomitant of employment, by other cognizant persons, or as the incidental result of transient passage through areas where analysis shows the exposure levels may be above those shown for uncontrolled environments but do not exceed the values shown for controlled environments in the table of maximum permitted exposure ceilings.

Maximum permitted exposures

The maximum permitted exposures prescribed by the standard are set in terms of different parameters of effects, depending on the frequency generated by the equipment in question. At the frequency range of this Personal Communication System equipment, 1930-1970MHz, the maximum permitted exposure levels are set in terms of power density, whose definition and relationship to electric field and magnetic field strengths are described by the standard as follows:

Power density (S)

Power per unit area normal to the direction of propagation, usually expressed in units of watts per square metre (W/m^2) or, for convenience, units such as milliwatts per square centimetre (mW/cm^2). For plane waves, power density, electric field strength (E) and magnetic field strength (H) are related by the impedance of free space, 377 ohms. In particular,

$$S = \frac{E^2}{377} = 377 \times H^2$$

where E and H are expressed in units of V/m and A/m, respectively, and S in units of W/m^2 . Although many survey instruments indicate power density units, the actual quantities measured are E or E^2 or H or H^2 .

Maximum permitted exposure ceilings

Within the frequency range, the maximum permitted exposure ceiling for uncontrolled environments is a power density (mW/cm^2) that equals $f/1500$, where f is the frequency expressed in MHz, and measurements are averaged over a period of 30 minutes. The maximum permitted exposure ceiling for controlled environments, also expressed in mW/cm^2 , is $f/300$ where measurements are averaged over 6 minutes. Applying these principles to the minimum and maximum frequencies for which this equipment is intended to be used yields the following maximum permitted exposure levels:

	Uncontrolled Environment		Controlled Environment	
	1930MHz	1970MHz	1930MHz	1970MHz
Ceiling	1.287 mW/cm^2	1.313 mW/cm^2	6.433 mW/cm^2	6.567 mW/cm^2

If you plan to operate the equipment at more than one frequency, compliance should be assured at the frequency which produces the lowest exposure ceiling (among the frequencies at which operation will occur).

Licensees must be able to certify to the FCC that their facilities meet the above ceilings. Some lower power PCS devices, 100 milliwatts or less, are excluded from demonstrating compliance, but this equipment operates at power levels orders of magnitude higher, and the exclusion is not applicable.

Whether a given installation meets the maximum permitted exposure ceilings depends, in part, upon antenna type, antenna placement and the output power to which this equipment is adjusted. The following example sets forth the distances from the antenna to which access should be prevented in order to comply with the uncontrolled and controlled environment exposure limits as set forth in the ANSI IEEE standards and computed above.

Example calculation

For a base station with the following characteristics, what is the minimum distance from the antenna necessary to meet the requirements of an uncontrolled environment?

Transmit frequency	1930MHz
Base station cabinet output power, P	+39.0dBm (8 watts)
Antenna feeder cable loss, CL	2.0dB
Antenna input power P_{in}	$P-CL = +39.0-2.0 = +37.0$ dB (5 watts)
Antenna gain, G	16.4dBi (43.65)

Using the following relationship:

$$G = \frac{4\pi r^2 W}{P_{in}}$$

Where W is the maximum permissible power density in W/m^2 and r is the safe distance from the antenna in metres, the desired distance can be calculated as follows:

$$r = \sqrt{\frac{GP_{in}}{4\pi W}} = \sqrt{\frac{43.65 \times 5}{4\pi \times 12.87}} = 1.16m$$

where $W = 12.87 W/m^2$ was obtained from table listed above and converting from mW/cm^2 to W/m^2 .

NOTE

The above result applies only in the direction of maximum radiation of the antenna. Actual installations may employ antennas that have defined radiation patterns and gains that differ from the example set forth above. The distances calculated can vary depending on the actual antenna pattern and gain.

Power density measurements

While installation calculations such as the above are useful and essential in planning and design, validation that the operating facility using this equipment actually complies will require making power density measurements. For information on measuring RF fields for determining compliance with ANSI IEEE C95.1-1991, see *IEEE Recommended Practice for the Measure of Potentially Hazardous Electromagnetic Fields - RF and Microwave*, IEEE Std C95.3-1991. Copies of IEEE C95.1-1991 and IEEE C95.3-1991 may be purchased from the Institute of Electrical and Electronics Engineers, Inc., Attn: Publication Sales, 445 Hoes Lane, P.O. Box 1331, Piscataway, NJ 08855-1331, (800) 678-IEEE or from ANSI, (212) 642-4900. Persons responsible for installation of this equipment are urged to consult these standards in determining whether a given installation complies with the applicable limits.

Other equipment

Whether a given installation meets ANSI standards for human exposure to radio frequency radiation may depend not only on this equipment but also on whether the environments being assessed are being affected by radio frequency fields from other equipment, the effects of which may add to the level of exposure. Accordingly, the overall exposure may be affected by radio frequency generating facilities that exist at the time the licensee's equipment is being installed or even by equipment installed later. Therefore, the effects of any such facilities must be considered in site selection and in determining whether a particular installation meets the FCC requirements.

Beryllium health and safety precautions

Introduction

Beryllium (Be), is a hard silver/white metal. It is stable in air, but burns brilliantly in Oxygen.

With the exception of the naturally occurring Beryl ore (Beryllium Silicate), all Beryllium compounds and Beryllium metal are potentially highly toxic.

Health issues

Beryllium Oxide is used within some components as an electrical insulator. Captive within the component it presents no health risk whatsoever. However, if the component should be broken open and the Beryllium Oxide, which is in the form of dust, released, there exists the potential for harm.

Inhalation

Inhalation of Beryllium Oxide can lead to a condition known as Berylliosis, the symptoms of Berylliosis are similar to Pneumonia and may be identified by all or any of the following:

Mild poisoning causes fever, shortness of breath, and a cough that produces yellow/green sputum, or occasionally bloodstained sputum. Inflammation of the mucous membranes of the nose, throat, and chest with discomfort, possibly pain, and difficulty with swallowing and breathing.

Severe poisoning causes chest pain and wheezing which may progress to severe shortness of breath due to congestion of the lungs. Incubation period for lung symptoms is 2–20 days.

Exposure to moderately high concentrations of Beryllium in air may produce a very serious condition of the lungs. The injured person may become blue, feverish with rapid breathing and raised pulse rate. Recovery is usual but may take several months. There have been deaths in the acute stage.

Chronic response. This condition is more truly a general one although the lungs are mainly affected. There may be lesions in the kidneys and the skin. Certain features support the view that the condition is allergic. There is no relationship between the degree of exposure and the severity of response and there is usually a time lag of up to 10 years between exposure and the onset of the illness. Both sexes are equally susceptible. The onset of the illness is insidious but only a small number of exposed persons develop this reaction.

First aid

Seek immediate medical assistance. The casualty should be removed immediately from the exposure area and placed in a fresh air environment with breathing supported with Oxygen where required. Any contaminated clothing should be removed. The casualty should be kept warm and at rest until medical aid arrives.

Skin contact

Possible irritation and redness at the contact area. Persistent itching and blister formations can occur which usually resolve on removal from exposure.

First aid

Wash area thoroughly with soap and water. If skin is broken seek immediate medical assistance.

Eye contact

May cause severe irritation, redness and swelling of eyelid(s) and inflammation of the mucous membranes of the eyes.

First aid

Flush eyes with running water for at least 15 minutes. Seek medical assistance as soon as possible.

Handling procedures

Removal of components from printed circuit boards (PCBs) is to take place only at Motorola approved repair centres.

The removal station will be equipped with extraction equipment and all other protective equipment necessary for the safe removal of components containing Beryllium Oxide.

If during removal a component is accidentally opened, the Beryllium Oxide dust is to be wetted into a paste and put into a container with a spatula or similar tool. The spatula/tool used to collect the paste is also to be placed in the container. The container is then to be sealed and labelled. A suitable respirator is to be worn at all times during this operation.

Components which are successfully removed are to be placed in a separate bag, sealed and labelled.

Disposal methods

Beryllium Oxide or components containing Beryllium Oxide are to be treated as hazardous waste. All components must be removed where possible from boards and put into sealed bags labelled Beryllium Oxide components. These bags must be given to the safety and environmental adviser for disposal.

Under no circumstances are boards or components containing Beryllium Oxide to be put into the general waste skips or incinerated.

Product life cycle implications

Motorola GSM and analogue equipment includes components containing Beryllium Oxide (identified in text as appropriate and indicated by warning labels on the equipment). These components require specific disposal measures as indicated in the preceding (Disposal methods) paragraph. Motorola will arrange for the disposal of all such hazardous waste as part of its Total Customer Satisfaction philosophy and will arrange for the most environmentally "friendly" disposal available at that time.

General cautions

Introduction

Observe the following cautions during operation, installation and maintenance of the equipment described in the Motorola GSM manuals. Failure to comply with these cautions or with specific cautions elsewhere in the Motorola GSM manuals may result in damage to the equipment. Motorola assumes no liability for the customer's failure to comply with these requirements.

Caution labels

Personnel working with or operating Motorola equipment must comply with any caution labels fitted to the equipment. Caution labels must not be removed, painted over or obscured in any way.

Specific cautions

Cautions particularly applicable to the equipment are positioned within the text of this manual. These must be observed by all personnel at all times when working with the equipment, as must any other cautions given in text, on the illustrations and on the equipment.

Fibre optics

The bending radius of all fibre optic cables must not be less than 30 mm.

Static discharge

Motorola equipment contains CMOS devices that are vulnerable to static discharge. Although the damage caused by static discharge may not be immediately apparent, CMOS devices may be damaged in the long term due to static discharge caused by mishandling. Wear an approved earth strap when adjusting or handling digital boards.

See **Devices sensitive to static** for further information.

Devices sensitive to static

Introduction

Certain metal oxide semiconductor (MOS) devices embody in their design a thin layer of insulation that is susceptible to damage from electrostatic charge. Such a charge applied to the leads of the device could cause irreparable damage.

These charges can be built up on nylon overalls, by friction, by pushing the hands into high insulation packing material or by use of unearthed soldering irons.

MOS devices are normally despatched from the manufacturers with the leads shorted together, for example, by metal foil eyelets, wire strapping, or by inserting the leads into conductive plastic foam. Provided the leads are shorted it is safe to handle the device.

Special handling techniques

In the event of one of these devices having to be replaced observe the following precautions when handling the replacement:

- Always wear an earth strap which must be connected to the electrostatic point (ESP) on the equipment.
- Leave the short circuit on the leads until the last moment. It may be necessary to replace the conductive foam by a piece of wire to enable the device to be fitted.
- Do not wear outer clothing made of nylon or similar man made material. A cotton overall is preferable.
- If possible work on an earthed metal surface. Wipe insulated plastic work surfaces with an anti-static cloth before starting the operation.
- All metal tools should be used and when not in use they should be placed on an earthed surface.
- Take care when removing components connected to electrostatic sensitive devices. These components may be providing protection to the device.

When mounted onto printed circuit boards (PCBs), MOS devices are normally less susceptible to electrostatic damage. However PCBs should be handled with care, preferably by their edges and not by their tracks and pins, they should be transferred directly from their packing to the equipment (or the other way around) and never left exposed on the workbench.

Motorola GSM manual set

Introduction

The following manuals provide the information needed to operate, install and maintain the Motorola GSM equipment.

Generic manuals

The following are the generic manuals in the GSM manual set, these manuals are release dependent:

Category number	Name	Catalogue number
GSM-100-101	System Information: General	68P02901W01
GSM-100-201	Operating Information: GSM System Operation	68P02901W14
GSM-100-311	Technical Description: OMC in a GSM System	68P02901W31
GSM-100-313	Technical Description: OMC Database Schema	68P02901W34
GSM-100-320	Technical Description: BSS Implementation	68P02901W36
GSM-100-321	Technical Description: BSS Command Reference	68P02901W23
GSM-100-403	Installation & Configuration: GSM System Configuration	68P02901W17
GSM-100-423	Installation & Configuration: BSS Optimization	68P02901W43
GSM-100-501	Maintenance Information: Alarm Handling at the OMC	68P02901W26
GSM-100-521	Maintenance Information: Device State Transitions	68P02901W57
GSM-100-523	Maintenance Information: BSS Field Troubleshooting	68P02901W51
GSM-100-503	Maintenance Information: GSM Statistics Application	68P02901W56
GSM-100-721	Software Release Notes: BSS/RXCDR	68P02901W72

Tandem OMC

The following Tandem OMC manuals are part of the GSM manual set for systems deploying Tandem S300 and 1475:

Category number	Name	Catalogue number
GSM-100-202	Operating Information: OMC System Administration	68P02901W13
GSM-100-712	Software Release Notes: OMC System	68P02901W71

Scaleable OMC

The following Scaleable OMC manuals replace the equivalent Tandem OMC manuals in the GSM manual set:

Category number	Name	Catalogue number
GSM-100-202	Operating Information: Scaleable OMC System Administration	68P02901W19
GSM-100-413	Installation & Configuration: Scaleable OMC Clean Install	68P02901W47
GSM-100-712	Software Release Notes: Scaleable OMC System	68P02901W74

Related manuals

The following are related Motorola GSM manuals:

Category number	Name	Catalogue number
GSM-001-103	System Information: BSS Equipment Planning	68P02900W21
GSM-002-103	System Information: DataGen	68P02900W22
GSM-005-103	System Information: Advance Operational Impact	68P02900W25
GSM-008-403	Installation & Configuration: Expert Adviser	68P02900W36

Service manuals

The following are the service manuals in the GSM manual set, these manuals are not release dependent. The internal organization and makeup of service manual sets may vary, they may consist of from one to four separate manuals, but they can all be ordered using the overall catalogue number shown below:

Category number	Name	Catalogue number
GSM-100-020	Service Manual: BTS	68P02901W37
GSM-100-030	Service Manual: BSC/RXCDCR	68P02901W38
GSM-105-020	Service Manual: M-Cell2	68P02901W75
GSM-106-020	Service Manual: M-Cell6	68P02901W85
GSM-201-020	Service Manual: M-Cellcity	68P02901W95
GSM-202-020	Service Manual: M-Cellaccess	68P02901W65
GSM-101-SERIES	ExCell4 Documentation Set	68P02900W50
GSM-103-SERIES	ExCell6 Documentation Set	68P02900W70
GSM-102-SERIES	TopCell Documentation Set	68P02901W80
GSM-200-SERIES	M-Cellmicro Documentation Set	68P02901W90

Category number

The category number is used to identify the type and level of a manual. For example, manuals with the category number GSM-100-2xx contain operating information.

Catalogue number

The Motorola 68P catalogue number is used to order manuals.

Ordering manuals

All orders for Motorola manuals must be placed with your Motorola Local Office or Representative. Manuals are ordered using the catalogue number. Remember, specify the manual issue required by quoting the correct suffix letter.

Chapter 1

**Principles of Cellular
Telecommunications**

Chapter 1	
Principles of Cellular Telecommunications	i
Principles of Cellular Telecommunications	1-1
Objectives	1-1
Overview	1-2
Advantages of Cellular Communications	1-2
Network Components	1-4
Frequency Spectrum	1-6
Introduction	1-6
Cell Size	1-8
Large Cells	1-8
Small Cells	1-8
The Trade Off – Large vs Small	1-8
Frequency Re-use	1-10
Co-channel Interference	1-10
Adjacent Channel Interference	1-10
Sectorization	1-12
Using Sectored Sites	1-14
4 Site/3 Cell	1-14
Switching and Control	1-16

Principles of Cellular Telecommunications

Objectives

On completion of this section the student will be able to:

- Name the main components of a cellular network and describe their functionality.
- Understand the options available for site configuration.

Principles of Cellular Telecommunications

Overview

A cellular telephone system links mobile station (MS) subscribers into the public telephone system or to another cellular system's MS subscriber.

Information sent between the MS subscriber and the cellular network uses radio communication. This removes the necessity for the fixed wiring used in a traditional telephone installation.

Due to this, the MS subscriber is able to move around and become fully mobile, perhaps travelling in a vehicle or on foot.

Advantages of Cellular Communications

Cellular networks have many advantages over the existing "land" telephone networks. There are advantages for the network provider as well as the mobile subscriber.

Overview

Advantages to Mobile Subscriber

- **Mobility**
- **Flexibility**
- **Convenience**

Advantages to Network Provider

- **Network expansion flexibility**
- **Revenue/profit margins**
- **Efficiency**
- **Easier re-configuration**

Network Components

GSM networks are made up of Mobile services Switching Centres (MSC), Base Station Systems (BSS) and Mobile Stations (MS). These three entities can be broken down further into smaller entities; such as, within the BSS we have Base Station Controllers, Base Transceiver Stations and Transcoders. These smaller network elements, as they are referred to, will be discussed later in the course. For now we will use the three major entities.

With the MSC, BSS and MS we can make calls, receive calls, perform billing etc, as any normal PSTN network would be able to do. The only problem for the MS is that all the calls made or received are from other MSs. Therefore, it is also necessary to connect the GSM network to the PSTN.

Mobile Stations within the cellular network are located in "cells", these cells are provided by the BSSs. Each BSS can provide one or more cells, dependent on the manufacturers equipment.

The cells are normally drawn as hexagonal, but in practice they are irregularly shaped, this is as a result of the influence of the surrounding terrain, or of design by the network planners.

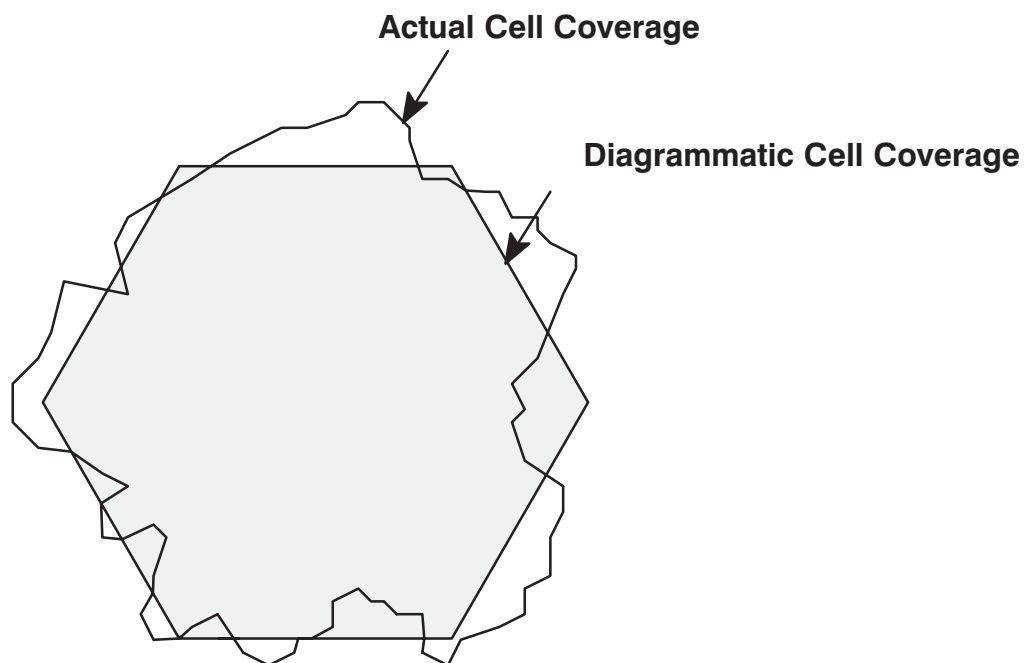

Network Components

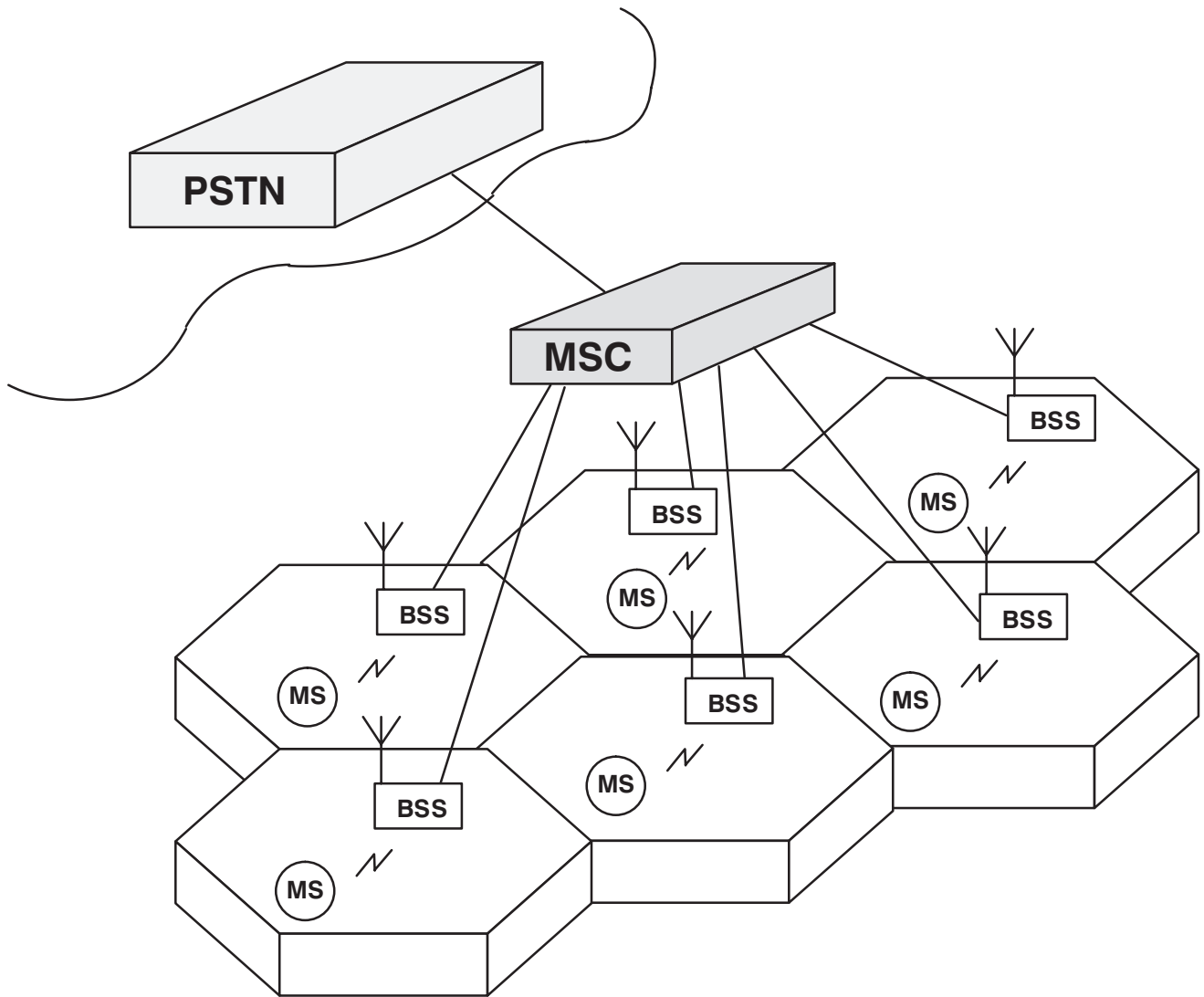

- PSTN** (Public Switched Telephone Network)
- MSC** (Mobile service Switching Centre)
- BSS** (Base Station System)
- MS** (Mobile Station)
- (Cell Coverage Area)**

Frequency Spectrum

Introduction

The frequency spectrum is very congested, with only narrow slots of bandwidth allocated for cellular communications. The list opposite shows the number of frequencies and spectrum allocated for GSM, Extended GSM 900 (EGSM), GSM 1800 (DCS1800) and PCS1900.

A single Absolute Radio Frequency Channel Number (ARFCN) or RF carrier is actually a pair of frequencies, one used in each direction (transmit and receive). This allows information to be passed in both directions. For GSM900 and EGSM900 the paired frequencies are separated by 45 MHz, for DCS1800 the separation is 95 MHz and for PCS1900 separation is 80 MHz.

For each cell in a GSM network at least one ARFCN must be allocated, and more may be allocated to provide greater capacity.

The RF carrier in GSM can support up to eight Time Division Multiple Access (TDMA) timeslots. That is, in theory, each RF carrier is capable of supporting up to eight simultaneous telephone calls, but as we will see later in this course although this is possible, network signalling and messaging may reduce the overall number from eight timeslots per RF carrier to six or seven timeslots per RF carrier, therefore reducing the number of mobiles that can be supported.

Unlike a PSTN network, where every telephone is linked to the land network by a pair of fixed wires, each MS only connects to the network over the radio interface when required. Therefore, it is possible for a single RF carrier to support many more mobile stations than its eight TDMA timeslots would lead us to believe. Using statistics, it has been found that a typical RF carrier can support up to 15, 20 or even 25 MSs. Obviously, not all of these MS subscribers could make a call at the same time, but it is also unlikely that all the MS subscribers would want to make a call at the same time. Therefore, without knowing it, MSs share the same physical resources, but at different times.

Frequency Range

GSM 900

- Receive (uplink) 890–915 MHz
- Transmit (downlink) 935–960 MHz
- 124 Absolute Radio Frequency Channels (ARFCN)

EGSM 900

- Receive (uplink) 880–915 MHz
- Transmit (downlink) 925–960 MHz
- 174 Absolute Radio Frequency Channels (ARFCN)

GSM 1800 (DCS1800)

- Receive (uplink) 1710–1785 MHz
- Transmit (downlink) 1805–1880 MHz
- 374 Absolute Radio Frequency Channels (ARFCN)

PCS 1900

- Receive (uplink) 1850–1910 MHz
- Transmit (downlink) 1930–1990 MHz
- 299 Absolute Radio Frequency Channels (ARFCN)

ARFCN

- Bandwidth = 200 KHz
- 8 TDMA timeslots

Cell Size

The number of cells in any geographic area is determined by the number of MS subscribers who will be operating in that area, and the geographic layout of the area (hills, lakes, buildings etc).

Large Cells

The maximum cell size for GSM is approximately 70 km in diameter, but this is dependent on the terrain the cell is covering and the power class of the MS. In GSM, the MS can be transmitting anything up to 8 Watts; obviously, the higher the power output of the MS the larger the cell size. If the cell site is on top of a hill, with no obstructions for miles, then the radio waves will travel much further than if the cell site was in the middle of a city, with many high-rise buildings blocking the path of the radio waves.

Generally large cells are employed in:

- Remote areas.
- Coastal regions.
- Areas with few subscribers.
- Large areas which need to be covered with the minimum number of cell sites.

Small Cells

Small cells are used where there is a requirement to support a large number of MSs, in a small geographic region, or where a low transmission power may be required to reduce the effects of interference. Small cells currently cover 200 m and upwards.

Typical uses of small cells:

- Urban areas.
- Low transmission power required.
- High number of MSs.

The Trade Off – Large vs Small

There is no right answer when choosing the type of cell to use. Network providers would like to use large cells to reduce installation and maintenance cost, but realize that to provide a quality service to their customers, they have to consider many factors, such as terrain, transmission power required, number of MSs etc. This inevitably leads to a mixture of both large and small cells.

Cell Size

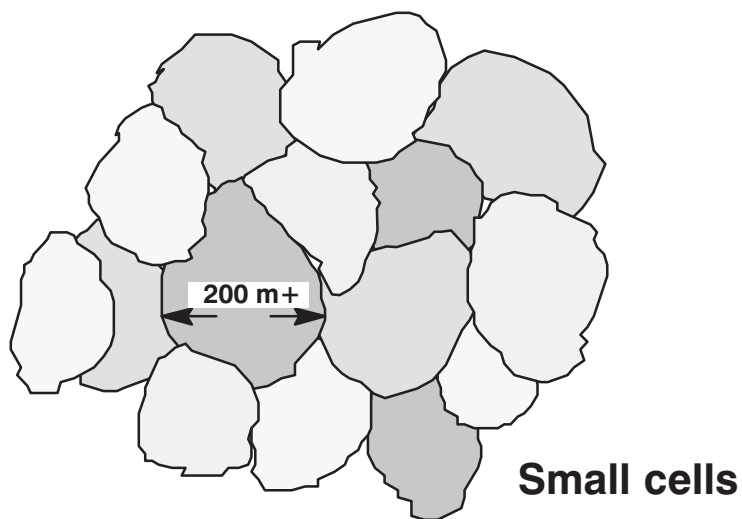
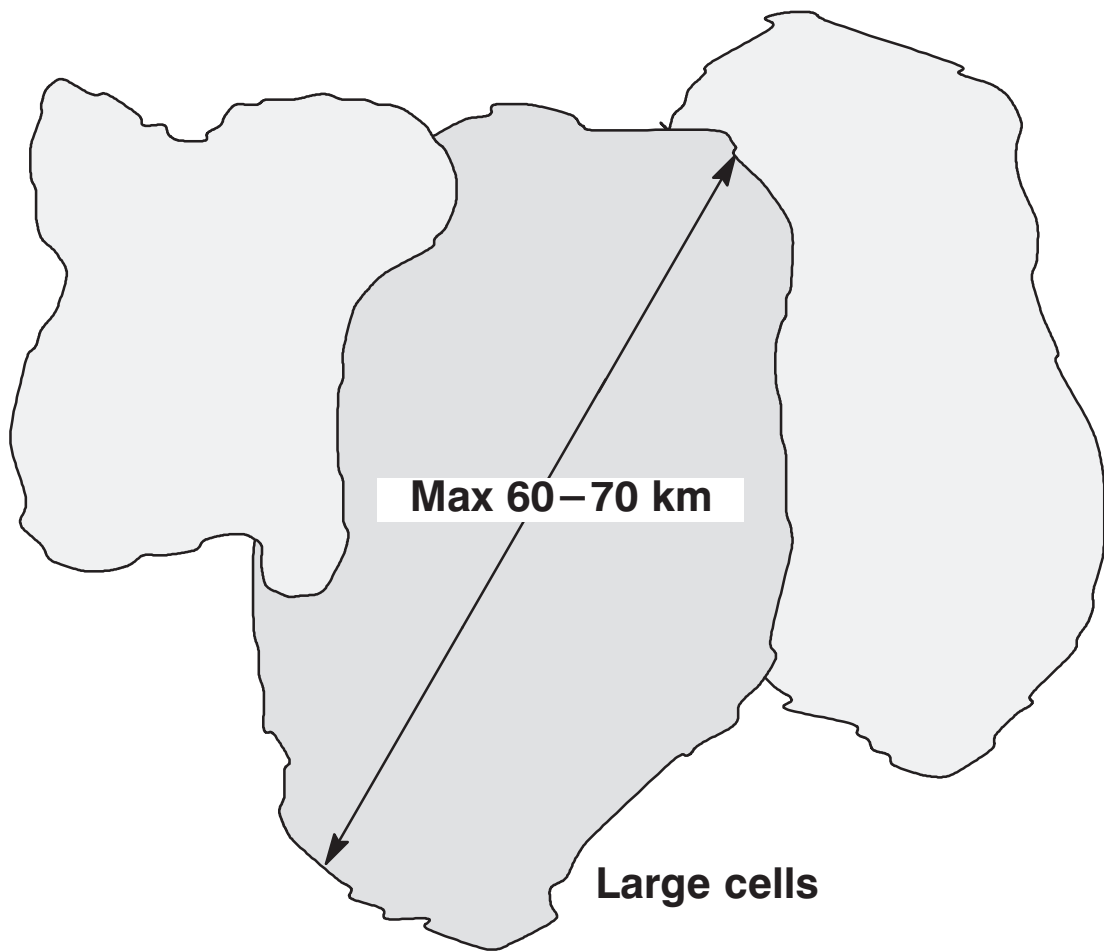

Frequency Re-use

Standard GSM has a total of 124 frequencies available for use in a network. Most network providers are unlikely to be able to use all of these frequencies and are generally allocated a small subset of the 124.

Example:

A network provider has been allocated 48 frequencies to provide coverage over a large area, let us take for example Great Britain.

As we have already seen, the maximum cell size is approximately 70 km in diameter, thus our 48 frequencies would not be able to cover the whole of Britain.

To overcome this limitation the network provider must re-use the same frequencies over and over again, in what is termed a "frequency re-use pattern".

When planning the frequency re-use pattern the network planner must take into account how often to use the same frequencies and determine how close together the cells are, otherwise co-channel and/or adjacent channel interference may occur. The network provider will also take into account the nature of the area to be covered. This may range from a densely populated city (high frequency re-use, small cells, high capacity) to a sparsely populated rural expanse (large omni cells, low re-use, low capacity).

Co-channel Interference

This occurs when RF carriers of the same frequency are transmitting in close proximity to each other, the transmission from one RF carrier interferes with the other RF carrier.

Adjacent Channel Interference

This occurs when an RF source of a nearby frequency interferes with the RF carrier.

Frequency Re-use

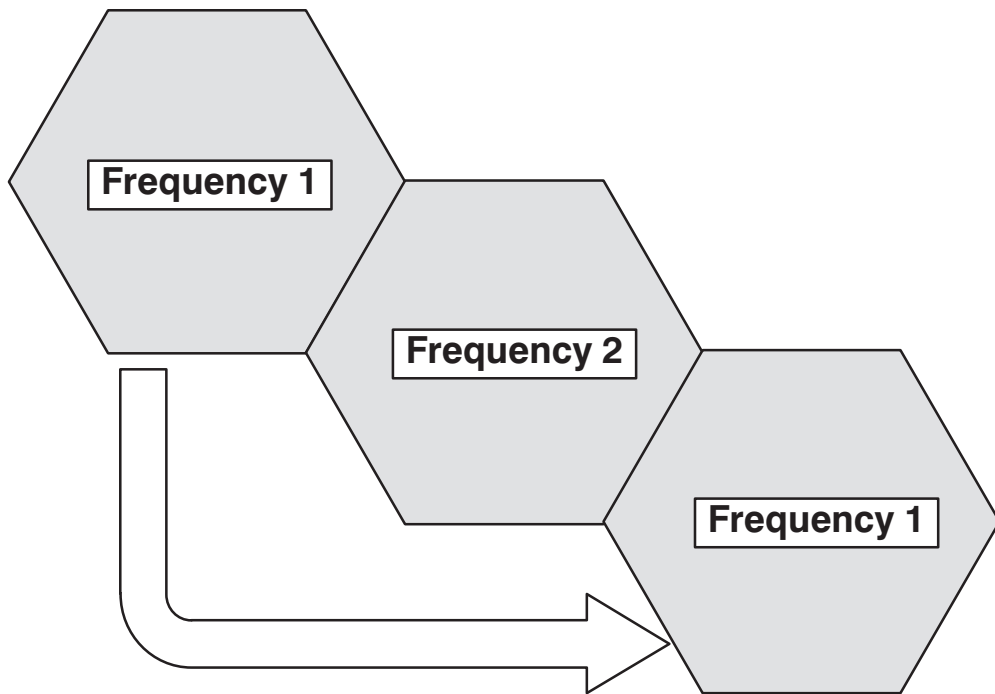

Sectorization

The cells we have looked at up to now are called omni-directional cells. That is each site has a single cell and that cell has a single transmit antenna which radiates the radio waves to 360 degrees.

The problem with employing omni-directional cells is that as the number of MSs increases in the same geographical region, we have to increase the number of cells to meet the demand. To do this, as we have seen, we have to decrease the size of the cell and fit more cells into this geographical area. Using omni-directional cells we can only go so far before we start introducing co-channel and adjacent channel interference, both of which degrade the cellular network's performance.

To gain a further increase in capacity within the geographic area we can employ a technique called "sectorization". Sectorization splits a single site into a number of cells, each cell has transmit and receive antennas and behaves as an independent cell.

Each cell uses special directional antennas to ensure that the radio propagation from one cell is concentrated in a particular direction. This has a number of advantages: firstly, as we are now concentrating all the energy from the cell in a smaller area 60, 120, 180 degrees instead of 360 degrees, we get a much stronger signal, which is beneficial in locations such as "in-building coverage". Secondly, we can now use the same frequencies in a much closer re-use pattern, thus allowing more cells in our geographic region which allows us to support more MSs.

Site Sectorization

360 Degree cells

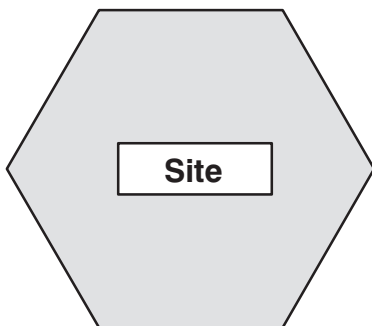

**Omni cell site
1 Transmit/receive
antenna**

120 Degree sectors/cells

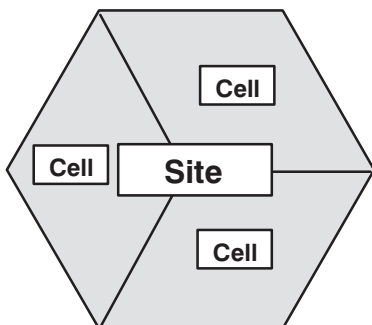

**3 cell site
3 Transmit/receive
antenna**

60 Degree sectors/cells

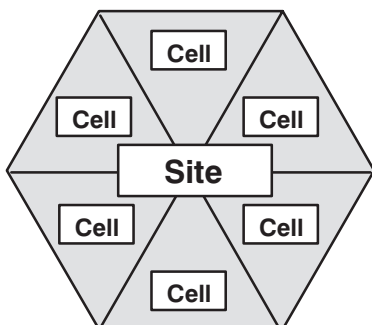

**6 cell site
6 Transmit/receive
antenna**

Using Sectored Sites

The distribution of RF carriers, and the size of the cells, is selected to achieve a balance between avoiding co-channel interference by geographically separating cells using the same RF frequencies, and achieving a channel density sufficient to satisfy the anticipated demand.

The diagram opposite illustrates how, by sectoring a site we can fit more cells into the same geographical area, thus increasing the number of MS subscribers who can gain access and use the cellular network.

This sectorization of sites typically occurs in densely populated areas, or where a high demand of MSs is anticipated, such as conference centres/business premises.

4 Site/3 Cell

A typical re-use pattern used in GSM planning is the 4 site/3 cell.

For example, the network provider has 36 frequencies available, and wishes to use the 4 site/3 cell re-use pattern he may split the frequencies up as follows:

Cell A1	Cell A2	Cell A3	Cell B1	Cell B2	Cell B3	Cell C1	Cell C2	Cell C3	Cell D1	Cell D2	Cell D3
1	2	3	4	5	6	7	8	9	10	11	12
13	14	15	16	17	18	19	20	21	22	23	24
25	26	27	28	29	30	31	32	33	34	35	36

In this configuration each cell has a total of 3 carriers and each site has a total of 9 carriers. If the provider wished to reconfigure to a 3 site/3 cell then the result would be:

Cell A1	Cell A2	Cell A3	Cell B1	Cell B2	Cell B3	Cell C1	Cell C2	Cell C3
1	2	3	4	5	6	7	8	9
10	11	12	13	14	15	16	17	18
19	20	21	22	23	24	25	26	27
28	29	30	31	32	33	34	35	36

As can be seen from the table, each cell now has 4 carriers and each site has 12 carriers. This has the benefit of supporting more subscribers in the same geographic region, but problems could arise with co-channel and adjacent channel interference.

4 site/3 cell

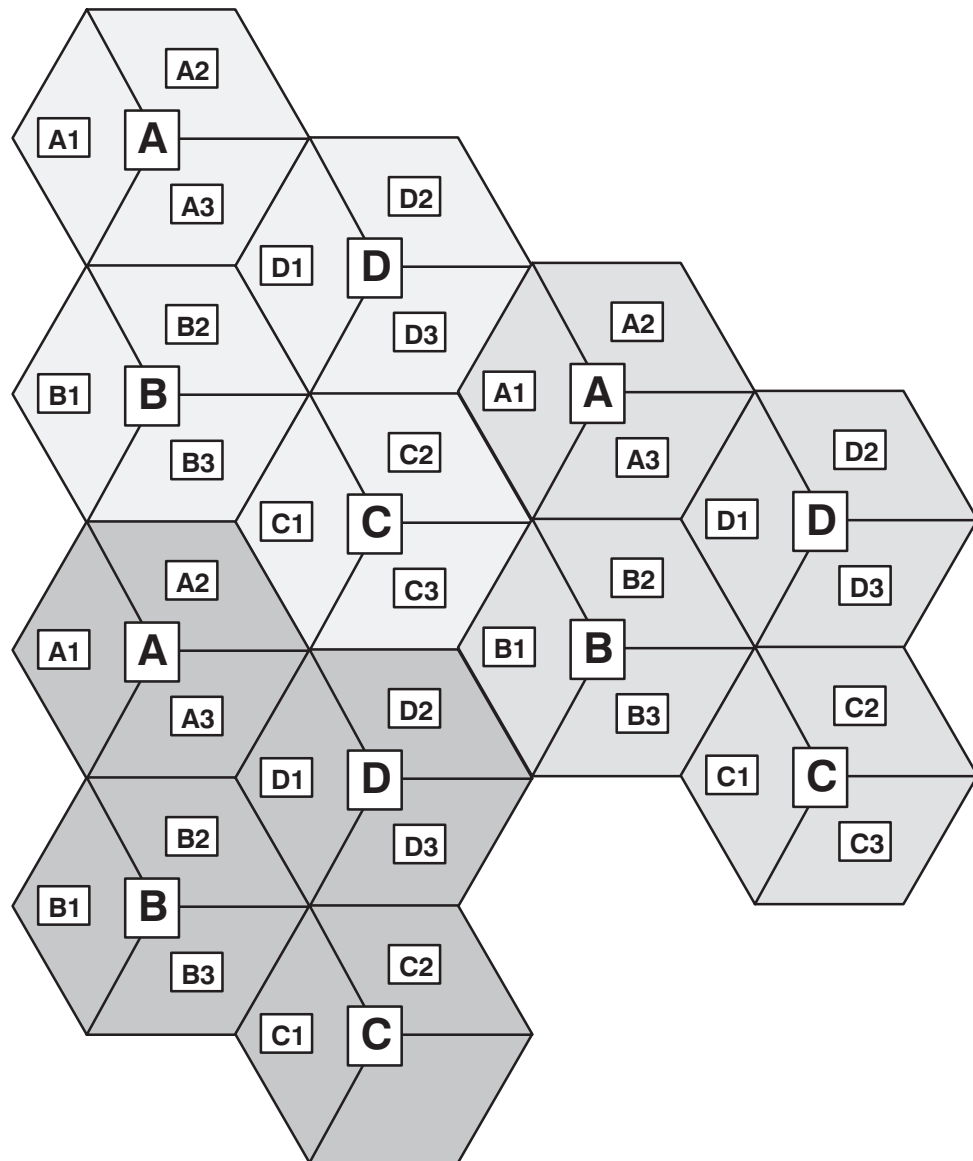

Switching and Control

Having established radio coverage through the use of cells, both omni-directional and directional (sectored sites), now consider what happens when the MS is in motion (as MSs tend to be).

At some point the MS will have to move from one cell's coverage area to another cell's coverage area. Handovers from one cell to another could be for a number of reasons (e.g. the signal strength of the "serving cell" is less than the signal strength of a "neighbour cell", or the MS is suffering a quality problem in the serving cell) and by handing over to one of its neighbours this may stop the quality problem.

Regardless of the reason for a "handover" it has to be controlled by some entity, and in GSM that entity is the Mobile services Switching Centre (MSC).

To perform a handover, the network must know which neighbour cell to hand the MS over to. To ensure that we handover to the best possible candidate the MS performs measurements of its surrounding neighbour cells and reports its findings to the network. These are then analyzed together with the measurements that the network performs and a decision is made on a regular basis as to the need for a handover. If a handover is required then the relevant signal protocols are established and the handover is controlled by the MSC.

Handovers must be transparent to the MS subscriber. That is the subscriber should be unaware that a handover has occurred.

As we will see later in this course, handovers are just one of the functions of the MSC, many more are performed by the MSC and its associated entities (e.g. such as authentication of MS, ciphering control, location updating, gateway to PSTN).

Note:

Some networks may allow certain handovers to be performed at the BSS level. This would be dependent on the manufacturer's equipment.

Switching and Control

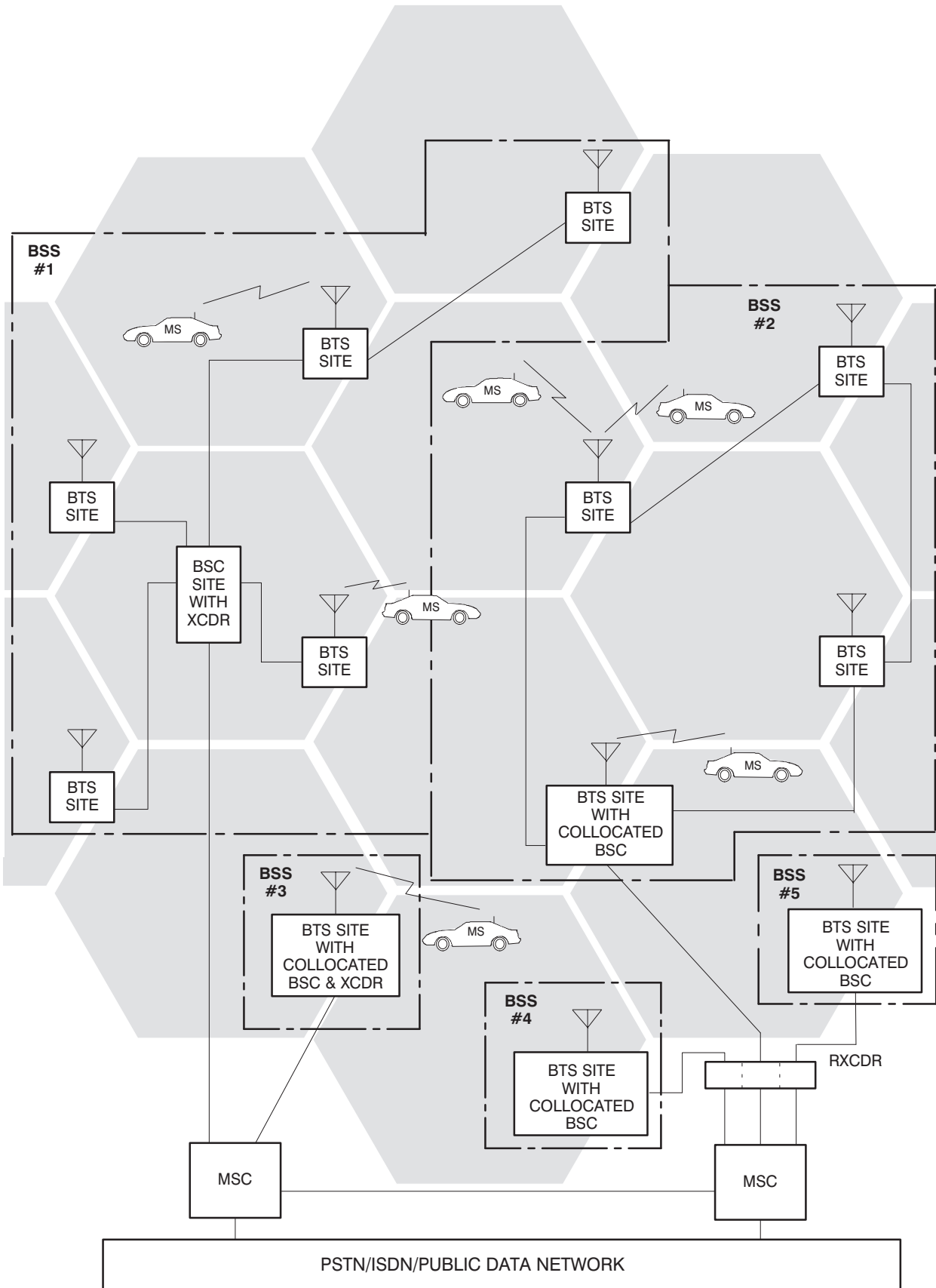

Chapter 2

Features of GSM

Chapter 2	
Features of GSM	i
Features of GSM	2-1
Section Objectives	2-1
Compatibility	2-2
Noise Robust	2-4
Flexibility and Increased Capacity	2-6
Use of Standardised Open Interfaces	2-8
Improved Security and Confidentiality	2-10
Flexible Handover Processes	2-12
ISDN Compatibility	2-14
2B+D	2-14
Enhanced Range Of Services	2-16
Speech Services	2-18
Telephony	2-18
Emergency Calls (with/without SIM Card inserted in MS)	2-18
Short Message Service Point To Point	2-18
Short Message Cell Broadcast	2-18
Advanced Message Handling Service	2-18
Dual Personal and Business Numbers	2-18
Data Services	2-20
Supplementary Services	2-22

Features of GSM

Section Objectives

On completion of this section the student will be able to:

- Understand the advantages of a digital air interface.
- Realise the implications of using standard open interfaces.
- Recognise the enhanced range of services that may be offered by a GSM network.
- Understand the part played by the mobile station in the handover process.
- Appreciate how software is used to provide flexibility.

Features of GSM

Cellular telephone systems provide the MS subscriber and network provider with many advantages over a standard telephone network, but there are still many drawbacks.

Compatibility

The rapid development of analogue cellular networks during the 1980s resulted in many different cellular systems which were incompatible with one another.

The need for a common standard for mobile telecommunications was therefore obvious, and so an executive body was set up to co-ordinate the complicated task of specifying the new standardized network.

GSM has been specified and developed by many European countries working in co-operation with each other. The result is a cellular system which has been implemented throughout Europe and many parts of the world.

An additional advantage resulting from this is that there is a large market for GSM equipment. This means that manufacturers can produce equipment in higher quantities and of better quality, and also, due to the number of manufacturers, a competitive and aggressive pricing structure exists. This results in lower costs for the MS subscriber and the network operators.

Compatibility

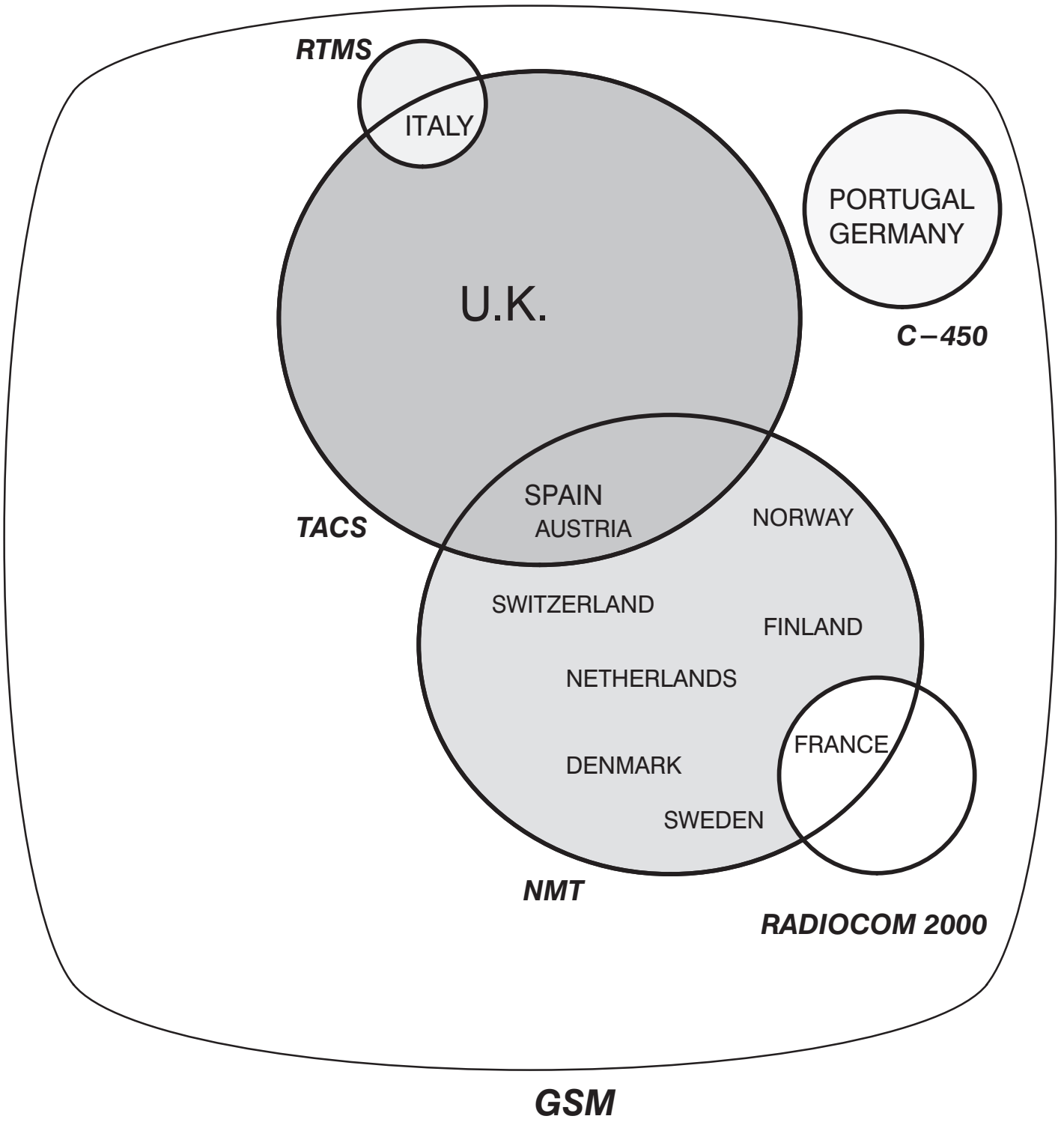

Noise Robust

In cellular telephone systems, such as AMPs, TACs or NMT the MS communicates with the cell site by means of analogue radio signals. Although this technique can provide an excellent audio quality (it is widely used for stereo radio broadcasting, for example), it is vulnerable to noise, as anyone who has tried to receive broadcast stereo with a poor aerial will testify!

The noise which interferes with the current system may be produced by any of the following sources:

- A powerful or nearby external source (a vehicle ignition system or a lightning bolt, perhaps);
- Another transmission on the same frequency (co-channel interference);
- Another transmission "breaking through" from a nearby frequency (adjacent channel interference);
- Background radio noise intruding because the required signal is too weak to exclude it.

In order to combat the problems caused by noise, GSM uses digital technology instead of analogue.

By using digital signals, we can manipulate the data and include sophisticated error protection, detection and correction software. The overall result is that the signals passed across the GSM air interface withstand more errors (that is, we can locate and correct more errors than current analogue systems). Due to this feature, the GSM air interface in harsh RF environments can produce a usable signal, where analogue systems would be unable to. This leads to better frequency re-use patterns and more capacity.

Sources of Noise

- **Vehicle ignition systems**
- **Lightning**
- **Co-channel interference**
- **Adjacent channel interference**
- **Background spurious noise**

GSM Answers

- **Digital interface**
- **Interleaving**
- **Error detection**
- **Error correction**

Flexibility and Increased Capacity

With an analogue air interface, every connection between an MS and a cell site requires a separate RF carrier, which in turn requires a separate set of RF hardware. In order to expand the capacity of a cell site by a given number of channels, an equivalent quantity of hardware must be added. This makes system expansion time consuming, expensive and labour intensive.

Re-configuration of an analogue site suffers similar problems since much of the equipment requires manual re-tuning and this makes the system inflexible.

GSM equipment is fully controlled by its software. Network re-configurations can be made quickly and easily with a minimum of manual intervention required. Also, since one carrier can support eight users, expansion can be made with less equipment.

An enhancement soon to be realised is the half rate speech channel, where mobiles will use new speech algorithms requiring half as much data to be sent over the air interface. By implementing half rate, one carrier will be able to support 16 users, effectively doubling the capacity of the network. However, this is the optimum since the mobile, as well as the BTS, will need to be modified to support half rate.

GSM networks also offer the flexibility of international roaming. This allows the mobile user to travel to foreign countries and still use their mobiles on the foreign network. If necessary, the user may leave their mobile equipment at home and carry only the SIM card, making use of a hired mobile or any available equipment.

GSMs use of a digital air interface makes it more resilient to interference from users on the same or nearby frequencies and so cells can be packed closer together, which means more carriers in a given area to give better frequency re-use.

Multi-band networks and mobiles are available where a user can make use of both the 900 MHz network and the 1800/1900 networks. The mobile must be capable of operation in dual frequency bands, however, to the user it will be transparent. This enables network operators to add in capacity and reduce network interference by using cells operating in different frequency bands. The operator will be required to show that they have made efficient use of their existing frequencies before they will be granted access to frequencies in another band. This means using techniques like sectorisation, microcells and frequency hopping.

GSM is highly software dependent and, although this makes it very complex, it also provides for a high degree of flexibility.

Flexibility/Increased Capacity

- **Easily (RF) configured (software driven)**
- **Half rate**
- **International roaming**
- **Better frequency re-use**
- **Multi-band operation**

Use of Standardised Open Interfaces

The equipment in each of the analogue cellular networks tends to be produced by one manufacturer. This is because the equipment is only designed to communicate with other equipment made by that manufacturer. This situation is very profitable for the manufacturers as they have a great deal of influence over the pricing of their product. Unfortunately for the MS user and the network provider, this means high prices.

The situation is very different with GSM, where standard interfaces such as **C7** and **X.25** are used throughout the network. This means that network planners can select different manufacturers for different pieces of hardware. Competition between manufacturers is therefore intense in the GSM market and manufacturers must ensure they support the latest developments at a competitive price.

In addition, network planners have a great deal of flexibility in where the network components are situated. This means that they can make the most efficient use of the terrestrial links which they operate.

Use of Standardized Open Interfaces

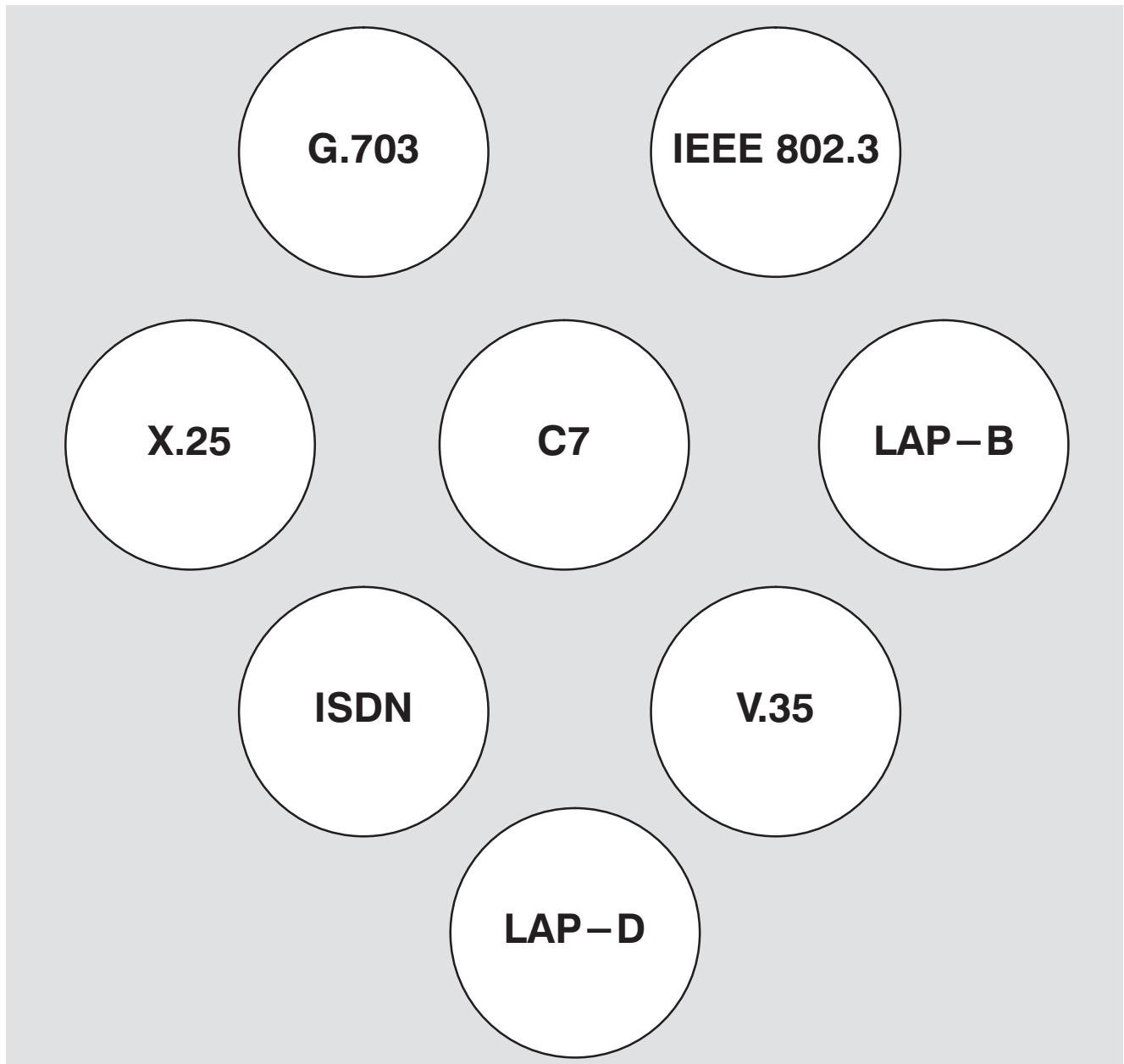

Improved Security and Confidentiality

Security figures high on the list of problems encountered by some operators of analogue systems. In some systems, it is virtually non-existent and the unscrupulous were quick to recognize this. With some of the "first generation" systems, it has been estimated that up to 20% of cellular phone calls are stolen.

Extensive measures have been taken, when specifying the GSM system, to substantially increase security with regard to both call theft and equipment theft.

With GSM, both the Mobile Equipment (ME) and Mobile Subscriber are identified. The ME has a unique number coded into it when it is manufactured. This can be checked against a database every time the mobile makes a call to validate the actual equipment. The subscriber is authenticated by use of a smart card known as a Subscriber Identity Module (SIM), again this allows the network to check a MS subscriber against a database for authentication.

GSM also offers the capability to encrypt all signalling over the air interface. Different levels of encryption are available to meet different subscriber/country requirements.

With the authentication processes for both the ME and subscriber, together with the encryption and the digital encoding of the air interface signals, it makes it very difficult for the casual "hacker" to listen-in to personal calls.

In addition to this, the GSM air interface supports frequency hopping; this entails each "burst" of information being transmitted to/from the MS/base site on a different frequency, again making it very difficult for an observer (hacker) to follow/listen to a specific call. Although it should be noted that frequency hopping is employed to optimize network performance by overcoming interference problems in busy areas, to increase call quality and capacity.

Improved Security and Confidentiality



- GSM Offers:**
- Encryption**
 - ME authentication**
 - Subscriber authentication (SIM)**
 - Frequency hopping**

Flexible Handover Processes

Handovers take place as the MS moves between cells, gradually losing the RF signal of one and gaining that of the other.

The MS switches from channel to channel and cell to cell as it moves to maintain call continuity. With analogue systems, handovers are frequently a problem area and the subscriber is often aware that a handover has occurred!

When GSM was specified a great deal of thought went into the design and implementation of handovers. Although the GSM system is more complicated than analogue in this area, the flexibility of the GSM handover processes offer significant improvements which provide a much better quality of service to the subscriber.

GSM provides handover processes for the following:

- Quality (uplink/downlink).
- Interference (uplink/downlink).
- RF level (uplink/downlink).
- MS distance.
- Power budget.

More handover algorithms have been developed for specific applications, such as microcellular, and are currently being implemented.

Flexible Handover Processes

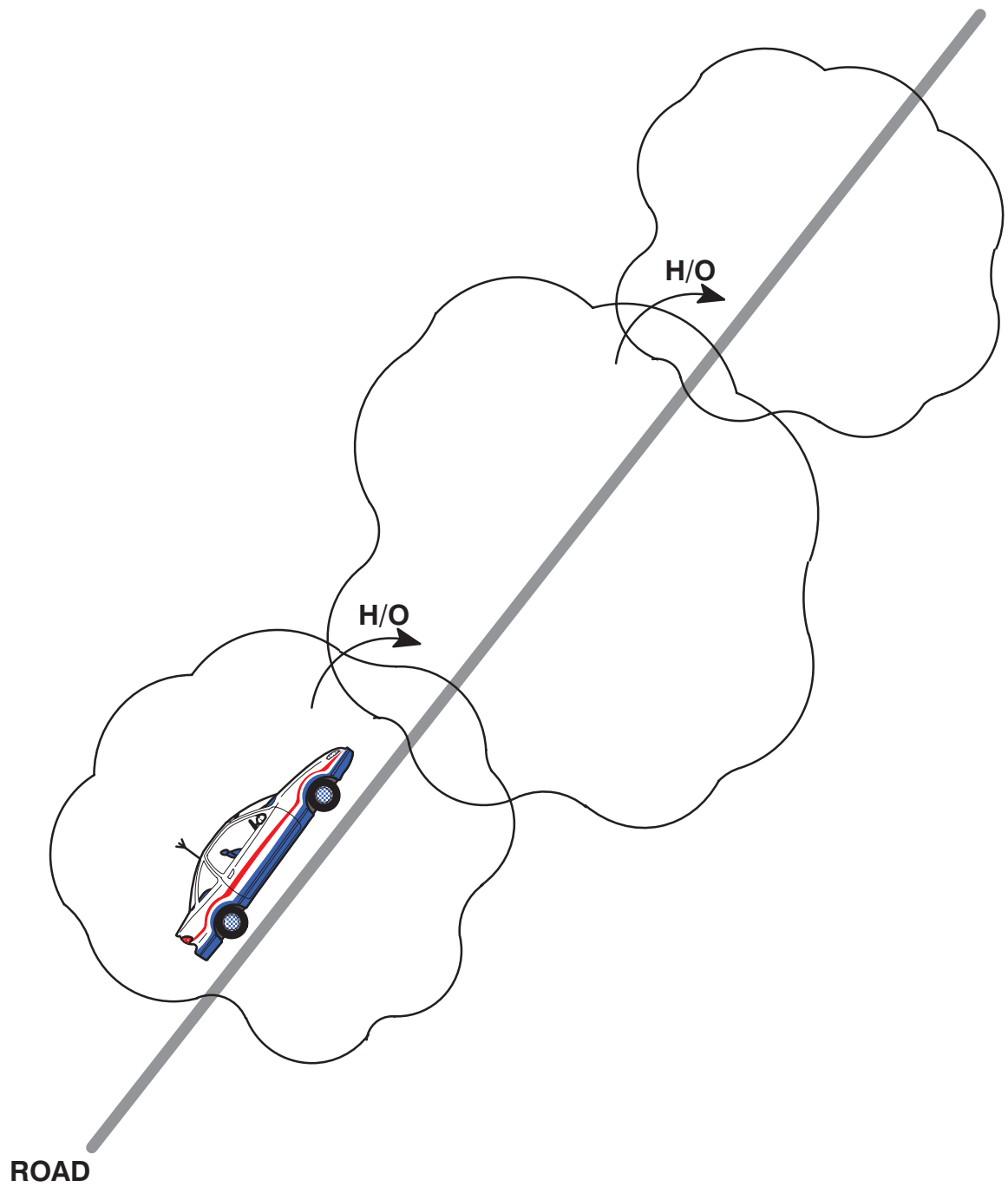

ISDN Compatibility

Integrated Services Digital Network (ISDN) is a standard that most developed countries are committed to implement. This is a new and advanced telecommunications network designed to carry voice and user data over standard telephone lines.

Major telephone companies in Europe, North America, Hong Kong, Australia and Japan are committed to commercial enterprises using ISDN.

The GSM network has been designed to operate with the ISDN system and provides features which are compatible with it. GSM can provide a maximum data rate of 9.6 kbit/s while ISDN provides much higher data rates than this (standard rate 64 kbit/s, primary rate 2.048 Mbit/s).

2B+D

This refers to the signals and information which may be carried on an ISDN line. There are effectively three connections, one for signalling ('D') and the other two for data or speech ('2B').

ISDN Compatibility

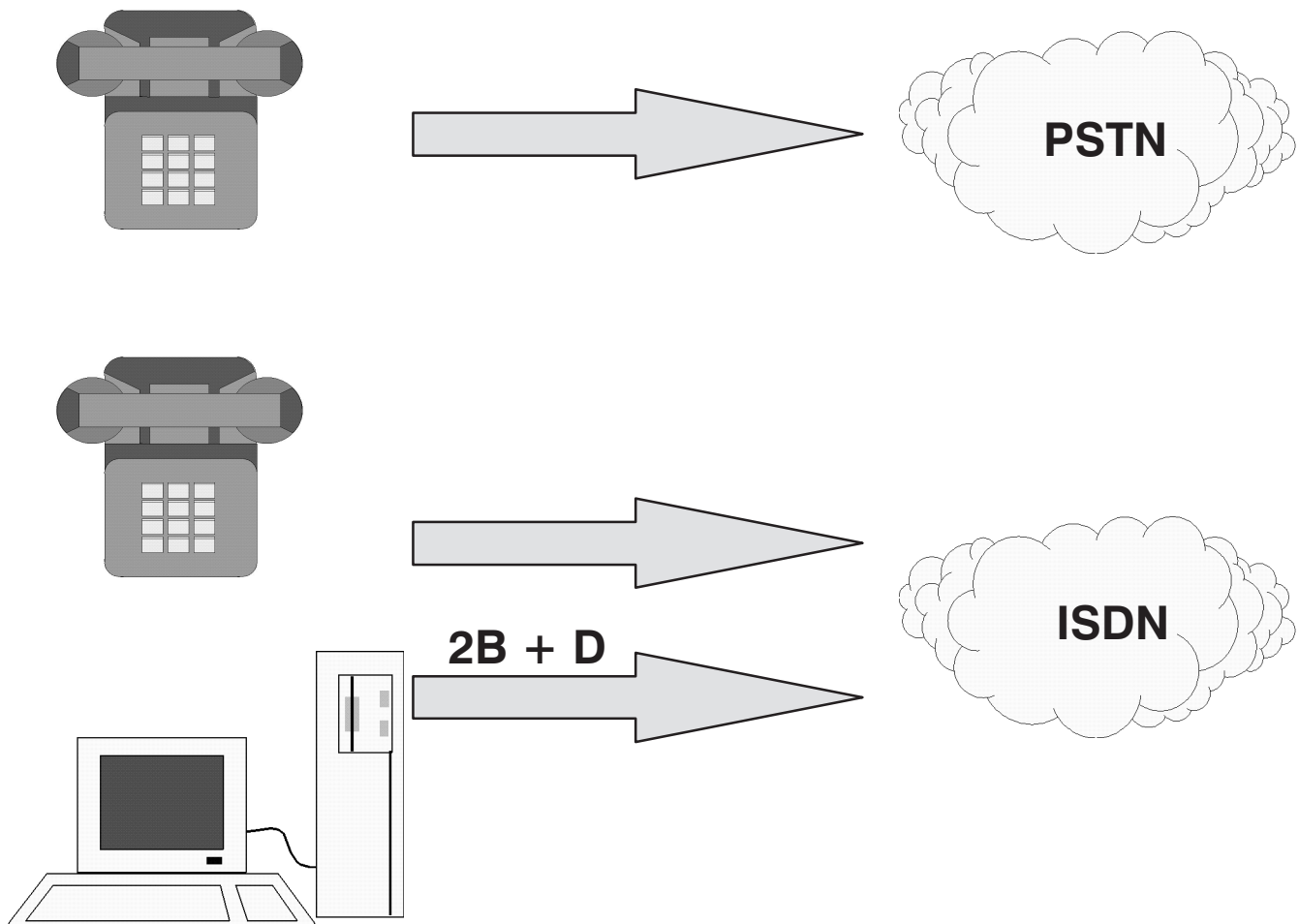

Note:

1. **B = 64 kbit/s**
 2. **D = 16 kbit/s**
- $\therefore 2B + D = 144 \text{ kbit/s}$

Enhanced Range Of Services

GSM has the potential to offer a greatly enhanced range of services compared to existing analogue cellular systems. As well as a full range of data transmission options and fax, there will be a wide range of supplementary services.

The basic call services which are already provided within analogue systems such as Call Forwarding, Voice Message Services etc, are already available in some operational systems. Whether these services and others are provided as part of the basic service or at additional cost to the subscriber will depend on the network provider.

When services were specified on GSM, the current land PSTN and ISDN system had to be taken into consideration; after all it is these systems we are most likely to be communicating with.

The services available to a subscriber will be determined by three factors:

- The level of service provided by the network provider.
- The level of service purchased by the subscriber.
- The capabilities of the subscriber's mobile equipment.

Enhanced Range of Services

- **Offered by network provider**
- **Purchased by subscriber**
- **Capabilities of mobile equipment**

Speech Services

The following services listed involve the transmission of speech information and would make up the basic service offered by a network provider:

Telephony

Provides for normal MS originated/terminated voice calls.

**Emergency Calls
(with/without SIM
Card inserted in
MS)**

The number "112" has been agreed as the international emergency call number. This should place you in contact with the emergency services (Police, Fire, Ambulance) whichever country you are in.

**Short Message
Service Point To
Point**

Provides the transmission of an acknowledged short message (128 bytes maximum) from a service centre to a MS. It is also intended that the MS should be able to send short messages to land-based equipment. This will obviously depend upon the equipment owned by the land-based user.

**Short Message
Cell Broadcast**

Provides the transmission of an unacknowledged short message (75 bytes maximum) from a service centre in the fixed network to all MSs within one cell. This may carry information from the network provider, for example traffic information or advertising.

**Advanced
Message
Handling Service**

Provides message submission and delivery from the storage from a public Message Handling System (MHS) for example, electronic mail.

**Dual Personal
and Business
Numbers**

Permits the allocation of dual telephone numbers to a single subscriber. This will allow calls to be made and be billed either to "business" or "personal" numbers.

Speech Services

- **Telephony**
- **Emergency calls**
- **Short message services**
- **Dual personal and business numbers**

Data Services

Data can be sent over the air using some of the present systems, but this requires specially designed “add ons” to protect the data content in the harsh environment of the air interface.

Special provision is made in the GSM technical specifications for data transmission. Therefore, like ISDN, GSM is “specially designed” for data transmission. GSM can be considered as an extension of ISDN into the wireless environment.

Text files, images, messages and fax may all be sent over the GSM network. The data rates available are 2.4 kbit/s, 4.8 kbit/s and 9.6 kbit/s.

In addition to supporting data transmission, GSM also provides for Group 3 Fax transmission.

Data Services

- **Raw Data:**
 - 9.6 kbit/s**
 - 4.8 kbit/s**
 - 2.4 kbit/s**
- **Fax**

Supplementary Services

A supplementary service is a modification of, or a supplement to, a basic telecommunication service. The network provider will probably charge extra for these services or use them as an incentive to join their network.

Here is a list of some of the optional supplementary subscriber services that could be offered to GSM subscribers:

Number Identification

- Receiving party requests calling number to be shown.
- Calling party requests calling number not to be shown.

Call Barring

- Bar all incoming or all outgoing calls.
- Bar specific incoming or outgoing calls.

Call Forwarding

- Forward all calls.
- Forward calls when subscriber is busy.
- Forward calls if subscriber does not answer.
- Forward calls if subscriber cannot be located.

Call Completion

- Enable incoming call to wait until subscriber completes current call.
- Enable subscriber to place incoming calls on hold.

Charging

- Display current cost of call.

Multi-party

- Three party service.
- Conference calling.

Supplementary Services

- **Number identification**
- **Call barring**
- **Call forwarding**
- **Call completion**
- **Charging**
- **Multi-party**

Chapter 3

GSM Network Components

Chapter 3	
GSM Network Components	i
GSM Network Components	3-1
Section Objectives	3-1
GSM Network Overview	3-2
Mobile Station (MS)	3-4
Mobile Equipment (ME)	3-6
Subscriber Identity Module (SIM)	3-8
Base Station System (BSS)	3-10
Base Station Controller (BSC)	3-12
Base Transceiver Station – BTS	3-12
BSS Configurations	3-14
Transcoder (XCDR)	3-16
Network Switching System	3-18
Mobile Services Switching Centre (MSC)	3-20
Home Location Register (HLR)	3-22
Visitor Location Register (VLR)	3-24
Location Area Identity	3-24
Temporary Mobile Subscriber Identity	3-24
Mobile Subscriber Roaming Number	3-24
Equipment Identity Register (EIR)	3-26
Authentication Centre (AUC)	3-28
Authentication Process	3-28
Interworking Function (IWF)	3-30
Echo Canceller (EC)	3-32
Operations and Maintenance System	3-34
Overview	3-34
Network Management Centre (NMC)	3-34
Operations and Maintenance Centre (OMC)	3-34
Network Management Centre (NMC)	3-36
Operations and Maintenance Centre (OMC)	3-38
The Network In Reality	3-40

GSM Network Components

Section Objectives

On completion of this section the student will be able to:

- Name the major components of a GSM network and know the functionality of these components.
- Draw a diagram illustrating how the components of the GSM network are connected.

GSM Network Overview

The diagram opposite shows a simplified GSM network. Each network component is illustrated only once, however, many of the components will occur several times throughout a network.

Each network component is designed to communicate over an interface specified by the GSM standards. This provides flexibility and enables a network provider to utilize system components from different manufacturers. For example Motorola Base Station System (BSS) equipment may be coupled with an Ericsson Network Switching System.

The principle component groups of a GSM network are:

- **The Mobile Station (MS)**

This consists of the mobile telephone, fax machine etc. This is the part of the network that the subscriber will see.
- **The Base Station System (BSS)**

This is the part of the network which provides the radio interconnection from the MS to the land-based switching equipment.
- **The Network Switching System**

This consists of the Mobile services Switching Centre (MSC) and its associated system-control databases and processors together with the required interfaces. This is the part which provides for interconnection between the GSM network and the Public Switched Telephone Network (PSTN).
- **The Operations and Maintenance System**

This enables the network provider to configure and maintain the network from a central location.

GSM Network Components

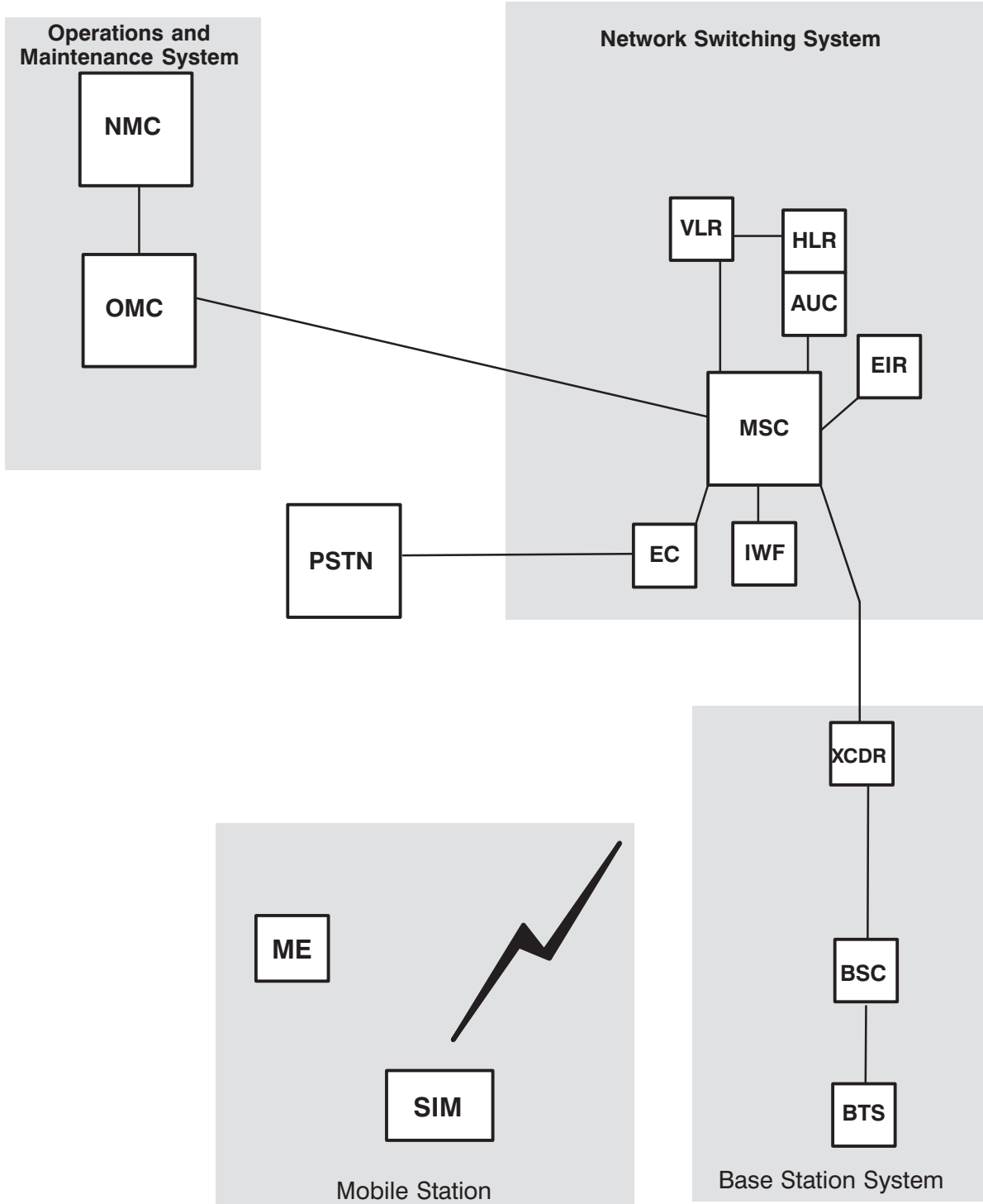

 **Interface/Connection**

Mobile Station (MS)

The MS consists of two parts, the Mobile Equipment (ME) and an electronic 'smart card' called a Subscriber Identity module (SIM).

The ME is the hardware used by the subscriber to access the network. The hardware has an identity number associated with it, which is unique for that particular device and permanently stored in it. This identity number is called the International Mobile Equipment Identity (IMEI) and enables the network operator to identify mobile equipment which may be causing problems on the system.

The SIM is a card which plugs into the ME. This card identifies the MS subscriber and also provides other information regarding the service that subscriber should receive. The subscriber is identified by an identity number called the International Mobile Subscriber Identity (IMSI).

Mobile Equipment may be purchased from any store but the SIM must be obtained from the GSM network provider. Without the SIM inserted, the ME will only be able to make emergency calls.

By making a distinction between the subscriber identity and the ME identity, GSM can route calls and perform billing based on the identity of the 'subscriber' rather than the equipment or its location.

Mobile Station

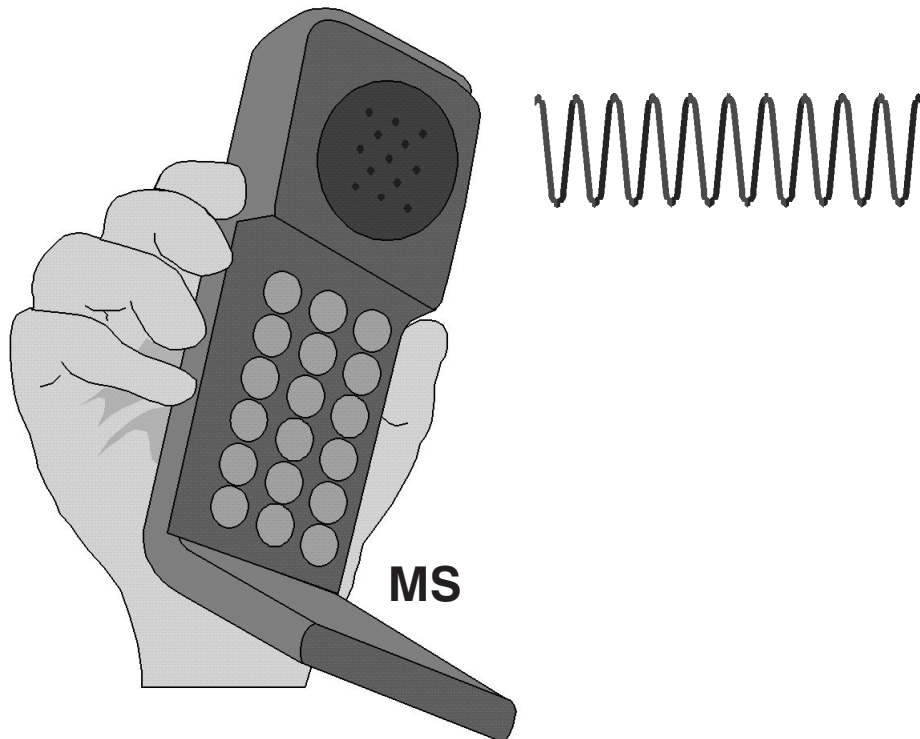

Mobile Station (MS)

- Mobile Equipment (ME)
- Subscriber Identity Module (SIM)

Mobile Equipment (ME)

The ME is the only part of the GSM network which the subscriber will really see. There are three main types of ME, these are listed below:

- **Vehicle Mounted**

These devices are mounted in a vehicle and the antenna is physically mounted on the outside of the vehicle.

- **Portable Mobile Unit**

This equipment can be handheld when in operation, but the antenna is not connected to the handset of the unit.

- **Handportable Unit**

This equipment comprises of a small telephone handset not much bigger than a calculator. The antenna is connected to the handset.

The ME is capable of operating at a certain maximum power output dependent on its type and use.

These mobile types have distinct features which must be known by the network, for example their maximum transmission power and the services they support. The ME is therefore identified by means of a classmark. The classmark is sent by the ME in its initial message.

The following pieces of information are held in the classmark:

- **Revision Level –**

Identifies the phase of the GSM specifications that the mobile complies with.

- **RF Power Capability –**

The maximum power the MS is able to transmit, used for power control and handover preparation. This information is held in the mobile power class number.

- **Ciphering Algorithm –**

Indicates which ciphering algorithm is implemented in the MS. There is only one algorithm (**A5**) in GSM phase 1, but GSM phase 2 specifies different algorithms (**A5/0–A5/7**).

- **Frequency Capability –**

Indicates the frequency bands the MS can receive and transmit on. Currently all GSM MSs use one frequency band, in the future this band will be extended but not all MSs will be capable of using it.

- **Short Message Capability –**

Indicates whether the MS is able to receive short messages.

Mobile Equipment Capabilities

- **RF power capability**

Power class	Power output
1	20 Watts (deleted)
2	8 Watts
3	5 Watts
4	2 Watts
5	0.8 Watts

- **Support of Phase 1, Phase 2 or Phase 2+ specification**
- **Encryption capability**
- **Frequency capability**
- **Short message services capability**

Subscriber Identity Module (SIM)

The SIM as mentioned previously is a “smart card” which plugs into the ME and contains information about the MS subscriber hence the name Subscriber Identity Module.

The SIM contains several pieces of information:

- **International Mobile Subscriber Identity (IMSI)**
This number identifies the MS subscriber. It is only transmitted over the air during initialization.
- **Temporary Mobile Subscriber Identity (TMSI)**
This number identifies the subscriber, it is periodically changed by the system management to protect the subscriber from being identified by someone attempting to monitor the radio interface.
- **Location Area Identity (LAI)**
Identifies the current location of the subscriber.
- **Subscriber Authentication Key (Ki)**
This is used to authenticate the SIM card.
- **Mobile Station International Services Digital Network (MSISDN)**
This is the telephone number of the mobile subscriber. It is comprised of a country code, a network code and a subscriber number.

Most of the data contained within the SIM is protected against reading (Ki) or alterations (IMSI). Some of the parameters (LAI) will be continuously updated to reflect the current location of the subscriber.

The SIM card, and the high degree of inbuilt system security, provide protection of the subscriber's information and protection of networks against fraudulent access. SIM cards are designed to be difficult to duplicate. The SIM can be protected by use of Personal Identity Number (PIN) password, similar to bank/credit charge cards, to prevent unauthorized use of the card.

The SIM is capable of storing additional information such as accumulated call charges. This information will be accessible to the customer via handset/keyboard key entry.

The SIM also executes the Authentication Algorithm.

Subscriber Identity Module (SIM)



↑
SIM CARD
(actual size)

FULL SIZE SIM CARD



MINI SIM CARD

Base Station System (BSS)

The GSM Base Station System is the equipment located at a cell site. It comprises a combination of digital and RF equipment. The BSS provides the link between the MS and the MSC.

The BSS communicates with the MS over the digital air interface and with the MSC via 2 Mbit/s links.

The BSS consists of three major hardware components:

- **The Base Transceiver Station – BTS**

The BTS contains the RF components that provide the air interface for a particular cell. This is the part of the GSM network which communicates with the MS. The antenna is included as part of the BTS.

- **The Base Station Controller – BSC**

The BSC as its name implies provides the control for the BSS. The BSC communicates directly with the MSC. The BSC may control single or multiple BTSs.

- **The Transcoder – XCDR**

The Transcoder **is used to compact the signals** from the MS so that they are more efficiently sent over the terrestrial interfaces. Although the transcoder is considered to be a part of the BSS, it is very often located closer to the MSC.

The transcoder is used to reduce the rate at which the traffic (voice/data) is transmitted over the air interface. Although the transcoder is part of the BSS, it is often found physically closer to the NSS to allow more efficient use of the terrestrial links.

Base Station System (BSS)

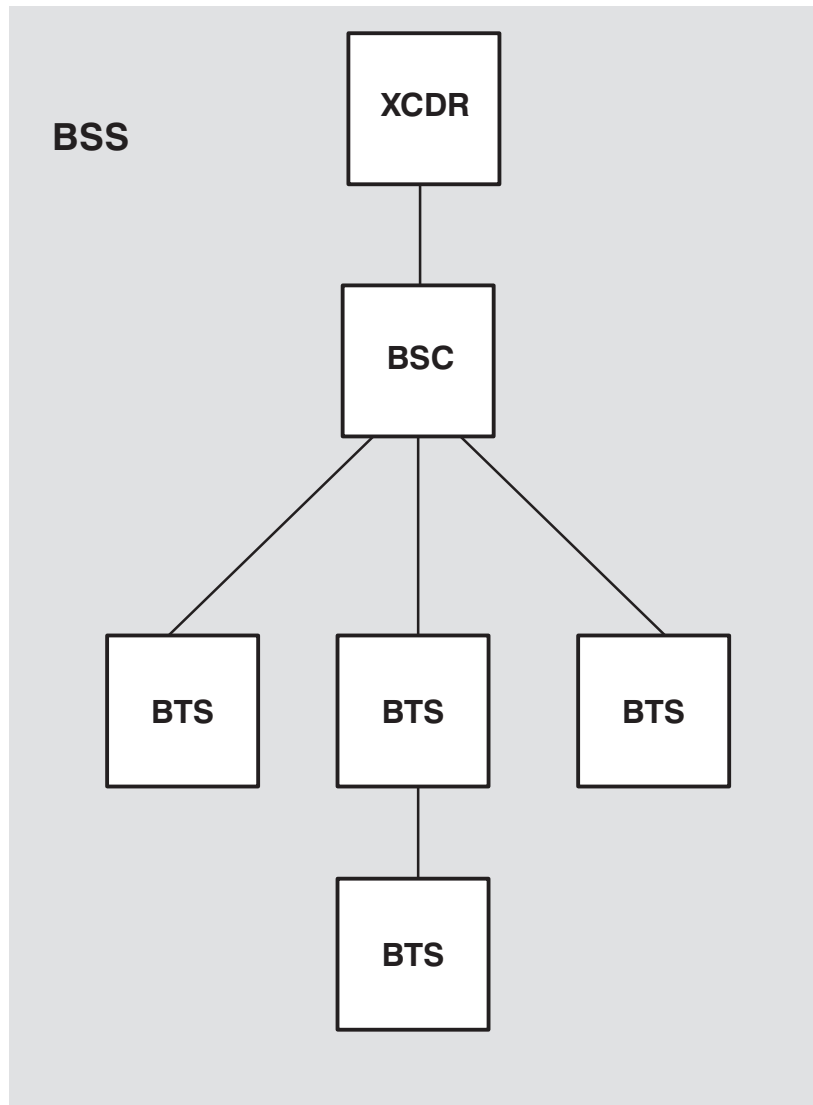

Base Station Controller (BSC)

As previously mentioned, the BSC provides the control for the BSS. The functions of the BSC are shown in the table opposite.

Any operational information required by the BTS will be received via the BSC. Likewise any information required about the BTS (by the OMC for example) will be obtained by the BSC.

The BSC incorporates a digital switching matrix, which it uses to connect the radio channels on the air interface with the terrestrial circuits from the MSC.

The BSC switching matrix also allows the BSC to perform "handovers" between radio channels on BTSs, under its control, without involving the MSC.

Base Transceiver Station – BTS

The BTS provides the air interface connection with the MS. It also has a limited amount of control functionality which reduces the amount of traffic passing between the BTS and BSC. The functions of the BTS are shown opposite. Each BTS will support 1 or more cells.

<i>BSS Functionality</i>	<i>Control</i>
Terrestrial Channel Management	
Channel Allocation	BSC
Radio Channel Management	BSC
Channel Configuration Management	BSC
Handover Control	BSC
Frequency Hopping	BSC/BTS
Traffic Channel Management	BSC/BTS
Control Channel Management	BSC/BTS
Encryption	BSC/BTS
Paging	BSC/BTS
Power Control	BSC/BTS
Channel Coding/Decoding	BTS
Timing Advance	BTS
Idle Channel Observation	BTS
Measurement Reporting	BTS

Where the BSC and BTS are both shown to control a function, the control is divided between the two, or may be located wholly at one.

Base Station System

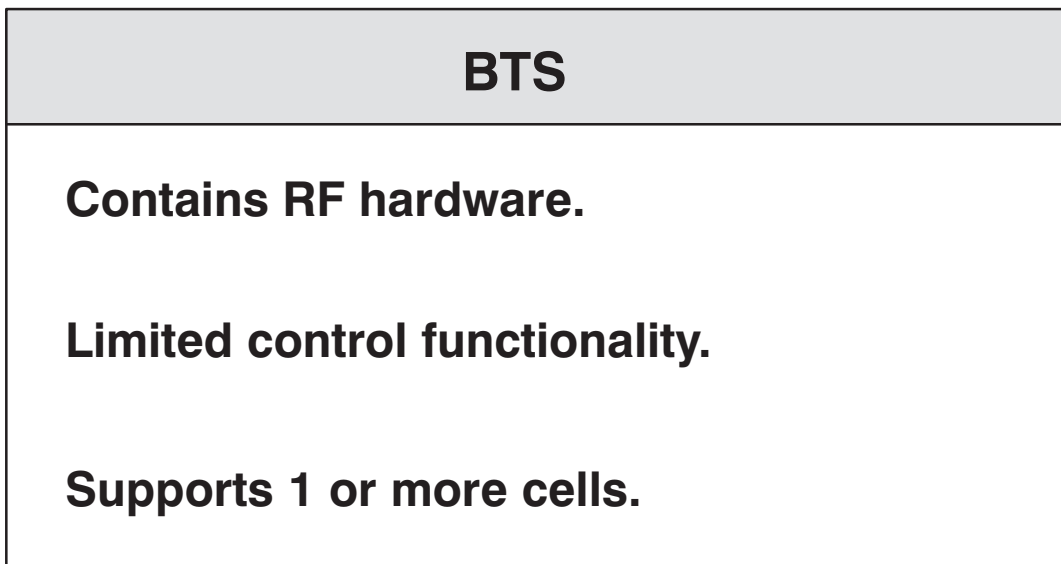
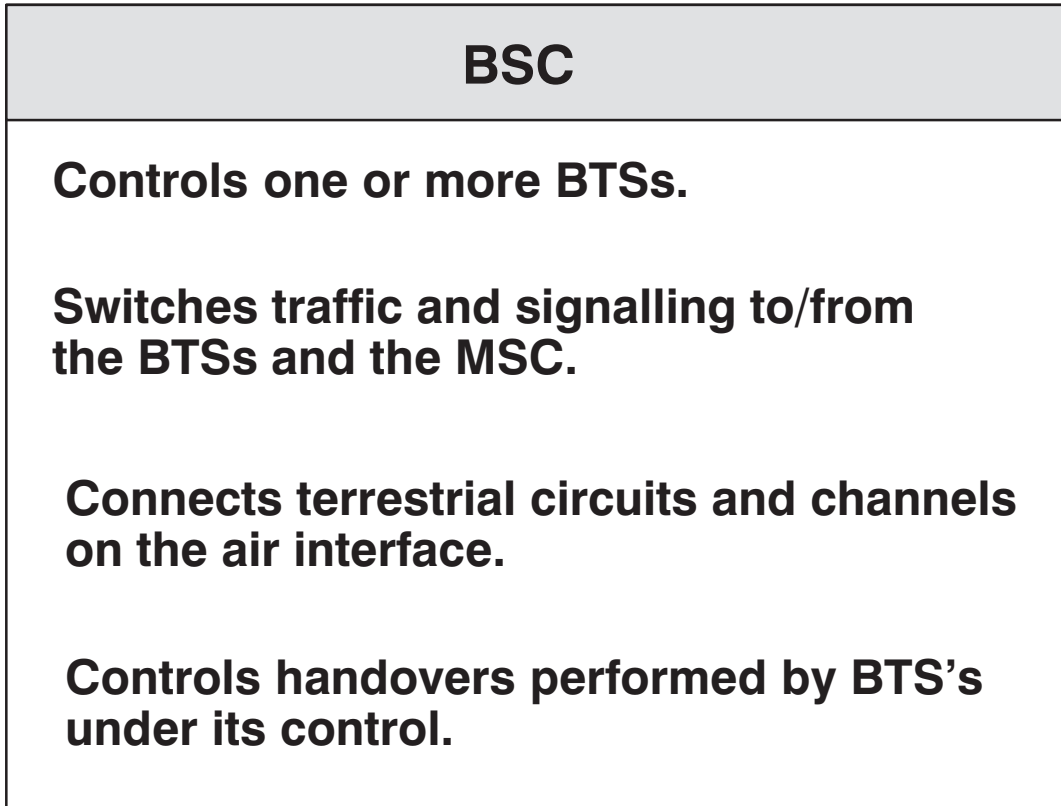

BSS Configurations

As we have mentioned, a BSC may control several BTSs, the maximum number of BTSs which may be controlled by one BSC is not specified by GSM.

Individual manufacturer's specifications may vary greatly.

The BTSs and BSC may either be located at the same cell site "co-located", or located at different sites "Remote". In reality most BTSs will be remote, as there are many more BTSs than BSCs in a network.

Another BSS configuration is the daisy chain. A BTS need not communicate directly with the BSC which controls it, it can be connected to the BSC via a chain of BTSs.

Daisy chaining reduces the amount of cabling required to set up a network as a BTS can be connected to its nearest BTS rather than all the way to the BSC.

Problems may arise when chaining BTSs, due to the transmission delay through the chain. The length of the chain must, therefore, be kept sufficiently short to prevent the round trip speech delay becoming too long.

Other topologies are also permitted, including stars and loops. Loops are used to introduce redundancy into the network, for example if a BTS connection was lost, the BTS may still be able to communicate with the BSC if a second connection is available.

BSS Configurations

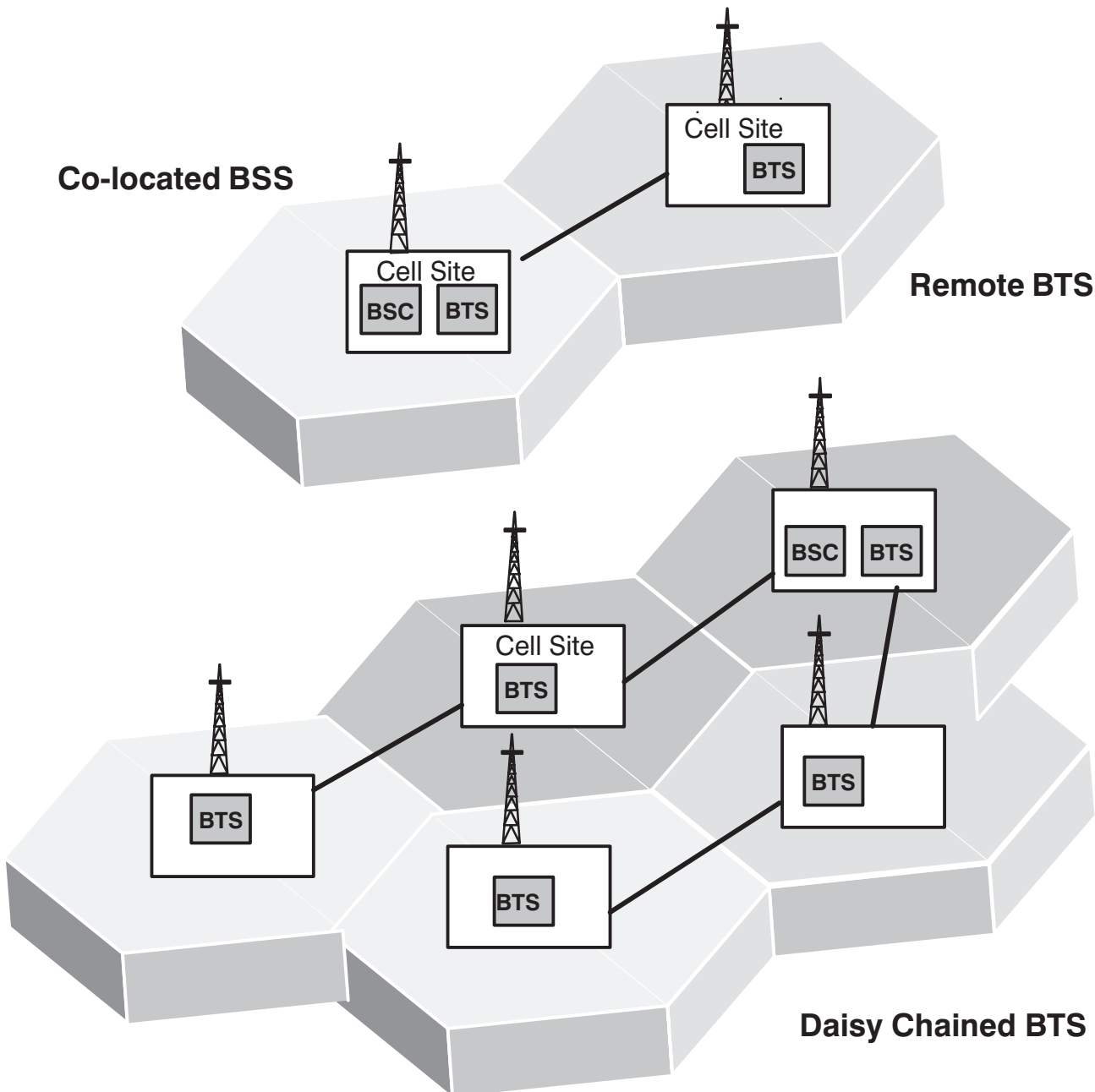

Transcoder (XCDR)

The Transcoder (XCDR) is required to convert the speech or data output from the MSC (64 kbit/s PCM), into the form specified by GSM specifications for transmission over the air interface, that is, between the BSS and MS (64 kbit/s to 16 kbit/s and vice versa)

The 64 kbit/s Pulse Code Modulation (PCM) circuits from the MSC, if transmitted on the air interface without modification, would occupy an excessive amount of radio bandwidth. This would use the available radio spectrum inefficiently. The required bandwidth is therefore reduced by processing the 64 kbit/s circuits so that the amount of information required to transmit digitized voice falls to a gross rate of 16 kbit/s.

The transcoding function may be located at the MSC, BSC, or BTS.

The content of the 16 kbit/s data depends on the coding algorithm used. There are two speech coding algorithms available and selecting which one to use depends on the capabilities of the mobile equipment and the network configuration.

The Full Rate speech algorithm is supported by all mobiles and networks. It produces 13 kbit/s of coded speech data plus 3 kbit/s of control data which is commonly referred to as TRAU data (Transcoder Rate Adaption Unit). The TRAU data on the downlink will be used by the BTS and therefore removed from the 13 k of speech data before transmission on the air interface. The 13 kbit/s of speech data is processed at the BTS to form a gross rate of 22.8 kbit/s on the air interface which includes forward error correction. In the uplink direction the BTS adds in TRAU data which will be used by the transcoder.

Enhanced Full Rate is an improved speech coding algorithm and is only supported by Phase 2+ mobiles and is optional in the Network. It produces 12.2 kbit/s from each 64 kbit/s PCM channel. The TRAU data in this case is made up to 3.8 kbit/s to keep the channel rate to and from the BTS at 16 kbit/s as for Full Rate. As with Full Rate the TRAU data is used at the BTS and Transcoder.

For data transmissions the data is not transcoded but data rate adapted from 9.6 kbit/s (4.8 kbit/s or 2.4 kbit/s may also be used) up to a gross rate of 16 kbit/s for transmission over the terrestrial interfaces, again this 16 kbit/s contains a 3 kbit/s TRAU.

As can be seen from the diagram opposite, although the reason for transcoding was to reduce the data rate over the air interface, the number of terrestrial links is also reduced approximately on a 4:1 ratio.

Transcoder

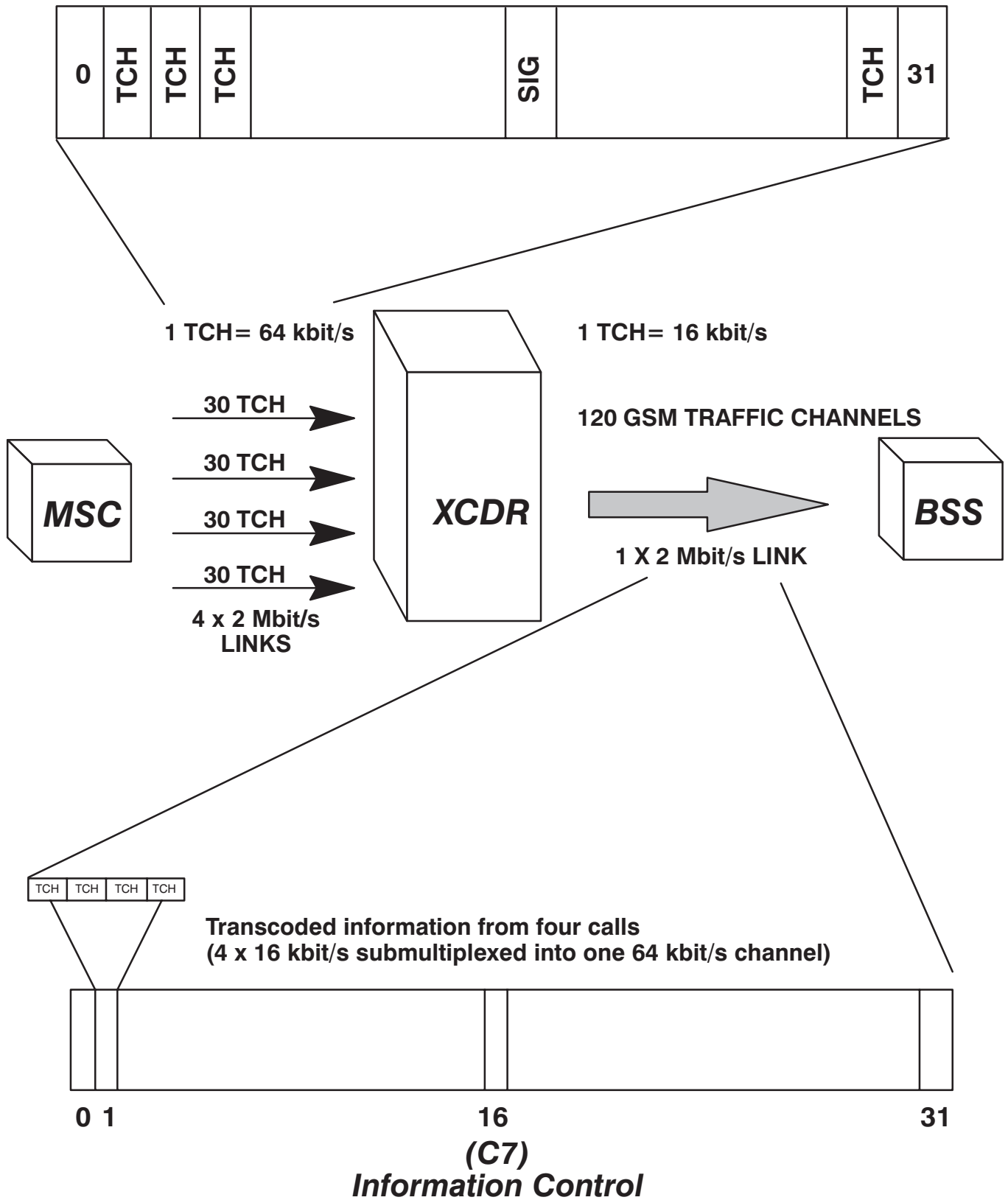

Network Switching System

The Network Switching System includes the main switching functions of the GSM network. It also contains the databases required for subscriber data and mobility management. Its main function is to manage communications between the GSM network and other telecommunications networks.

The components of the Network Switching System are listed below:

- Mobile Services Switching Centre – MSC
- Home Location Register – HLR
- Visitor Location Register – VLR
- Equipment Identity Register – EIR
- Authentication Centre – AUC
- InterWorking Function – IWF
- Echo Cancellor – EC

In addition to the more traditional elements of a cellular telephone system, GSM has Location Register network entities. These entities are the Home Location Register (HLR), Visitor Location Register (VLR), and the Equipment Identity Register (EIR). The location registers are database-oriented processing nodes which address the problems of managing subscriber data and keeping track of a MSs location as it roams around the network.

Functionally, the Interworking Function and the Echo Cancellers may be considered as parts of the MSC, since their activities are inextricably linked with those of the switch as it connects speech and data calls to and from the MSs.

The Network Switching System

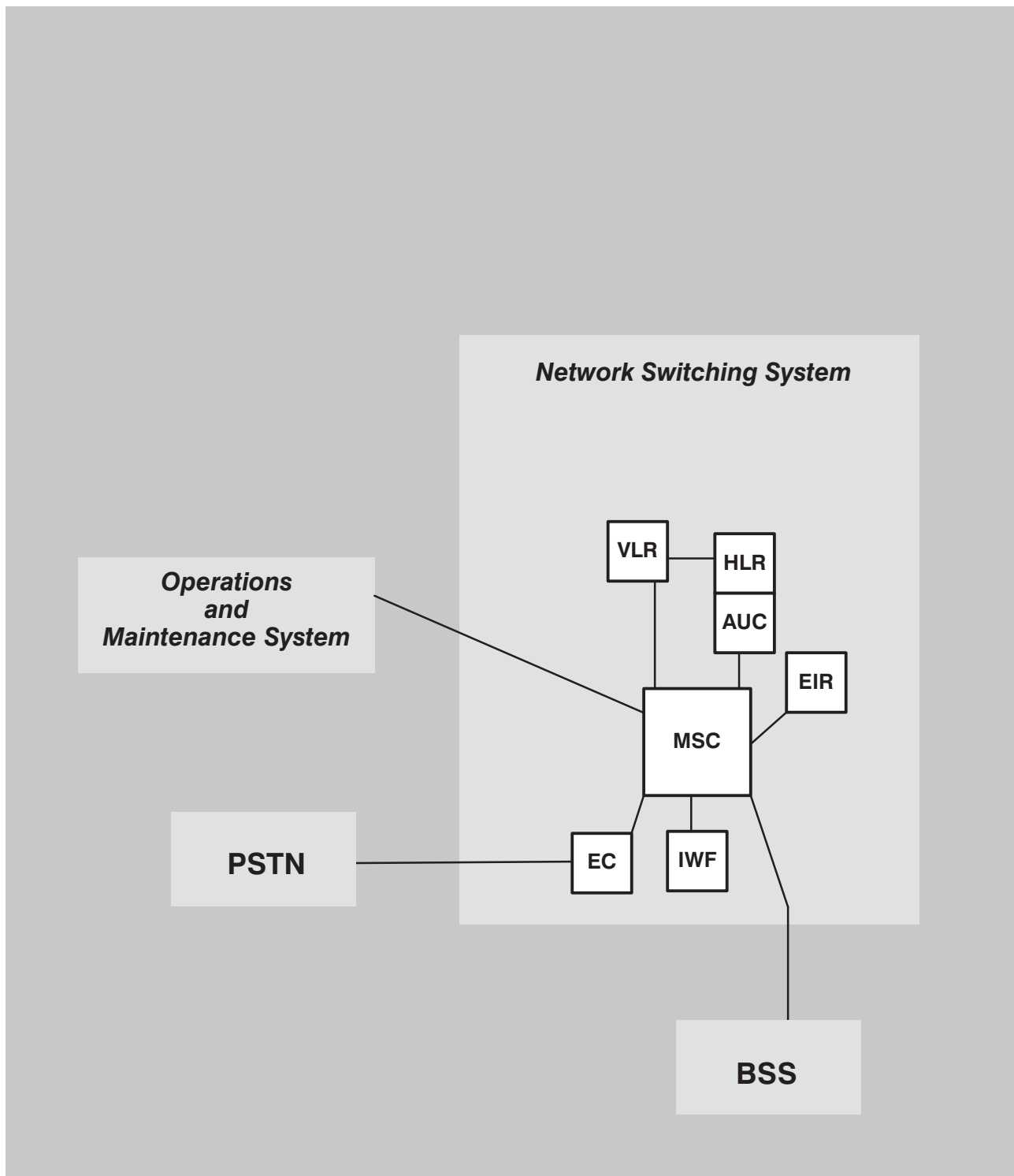

Mobile Services Switching Centre (MSC)

The MSC is included in the GSM system for call-switching. Its overall purpose is the same as that of any telephone exchange.

However, because of the additional complications involved in the control and security aspects of the GSM cellular system and the wide range of subscriber facilities that it offers, the MSC has to be capable of fulfilling many additional functions.

The MSC will carry out several different functions depending upon its position in the network. When the MSC provides the interface between the PSTN and the BSSs in the GSM network it will be known as a Gateway MSC. In this position it will provide the switching required for all MS originated or terminated traffic.

Each MSC provides service to MSs located within a defined geographic coverage area, the network typically contains more than one MSC. One MSC is capable of supporting a regional capital with approximately one million inhabitants. An MSC of this size will be contained in about half a dozen racks.

The functions carried out by the MSC are listed below:

- **Call Processing**
Includes control of data/voice call setup, inter-BSS and inter-MSC handovers and control of mobility management (subscriber validation and location).
- **Operations and Maintenance Support**
Includes database management, traffic metering and measurement, and a man-machine interface.
- **Internetwork Interworking**
Manages the interface between the GSM network and the PSTN.
- **Billing**
Collects call billing data.

Mobile Service Switching Centre

- **Call processing**
- **Operations & maintenance**
- **Internetwork interworking**
- **Billing**

Home Location Register (HLR)

The HLR is the reference database for subscriber parameters.

Various identification numbers and addresses are stored, as well as authentication parameters. This information is entered into the database by the network provider when a new subscriber is added to the system.

The parameters stored in the HLR are listed opposite:

The HLR database contains the master database of all the subscribers to a GSM PLMN. The data it contains is remotely accessed by all the MSCs and the VLRs in the network and, although the network may contain more than one HLR, there is only one database record per subscriber – each HLR is therefore handling a portion of the total subscriber database. The subscriber data may be accessed by either the IMSI or the MSISDN number. The data can also be accessed by an MSC or a VLR in a different PLMN, to allow inter-system and inter-country roaming.

Home Location Register (HLR)

- **Subscriber ID (IMSI and MSISDN)**
- **Current subscriber VLR (current location)**
- **Supplementary services subscribed to**
- **Supplementary service information (e.g. current forwarding number)**
- **Subscriber status (registered/deregistered)**
- **Authentication key and AUC functionality**
- **Mobile Subscriber Roaming Number**

Visitor Location Register (VLR)

The VLR contains a copy of most of the data stored at the HLR. It is, however, temporary data which exists for only as long as the subscriber is "active" in the particular area covered by the VLR. The VLR database will therefore contain some duplicate data as well as more precise data relevant to the subscriber remaining within the VLR coverage.

The VLR provides a local database for the subscribers wherever they are physically located within a PLMN, this may or may not be the "home" system. This function eliminates the need for excessive and time-consuming references to the "home" HLR database.

The additional data stored in the VLR is listed below:

- Mobile status (busy/free/no answer etc.).
- Location Area Identity (LAI).
- Temporary Mobile Subscriber Identity (TMSI).
- Mobile Station Roaming Number (MSRN).

Location Area Identity

Cells within the Public Land Mobile Network (PLMN) are grouped together into geographical areas. Each area is assigned a Location Area Identity (LAI), a location area may typically contain 30 cells. Each VLR controls several LAIs and as a subscriber moves from one LAI to another, the LAI is updated in the VLR. As the subscriber moves from one VLR to another, the VLR address is updated at the HLR.

Temporary Mobile Subscriber Identity

The VLR controls the allocation of new Temporary Mobile Subscriber Identity (TMSI) numbers and notifies them to the HLR. The TMSI will be updated frequently, this makes it very difficult for the call to be traced and therefore provides a high degree of security for the subscriber. The TMSI may be updated in any of the following situations:

- Call setup.
- On entry to a new LAI.
- On entry to a new VLR.

Mobile Subscriber Roaming Number

As a subscriber may wish to operate outside its "home" system at some time, the VLR can also allocate a Mobile Station Roaming Number (MSRN). This number is assigned from a list of numbers held at the VLR (MSC). The MSRN is then used to route the call to the MSC which controls the base station in the MSs current location.

The database in the VLR can be accessed by the IMSI, the TMSI or the MSRN. Typically there will be one VLR per MSC.

Visitor Location Register

- **Mobile Status**
- **Location Area Identity (LAI)**
- **Temporary Mobile Subscriber Identity (TMSI)**
- **Mobile Station Roaming Number (MSRN)**

Equipment Identity Register (EIR)

The EIR contains a centralized database for validating the International Mobile Equipment Identity (IMEI).

This database is concerned solely with MS equipment and not with the subscriber who is using it to make or receive a call.

The EIR database consists of lists of IMEIs (or ranges of IMEIs) organized as follows:

- **White List**
Contains those IMEIs which are known to have been assigned to valid MS equipment.
- **Black List**
Contains IMEIs of MS which have been reported stolen or which are to be denied service for some other reason.
- **Grey List**
Contains IMEIs of MS which have problems (for example, faulty software). These are not, however, sufficiently significant to warrant a “black listing”.

The EIR database is remotely accessed by the MSCs in the network and can also be accessed by an MSC in a different PLMN.

As in the case of the HLR, a network may well contain more than one EIR with each EIR controlling certain blocks of IMEI numbers. The MSC contains a translation facility, which when given an IMEI, returns the address of the EIR controlling the appropriate section of the equipment database.

Call Processing Functions (EIR)

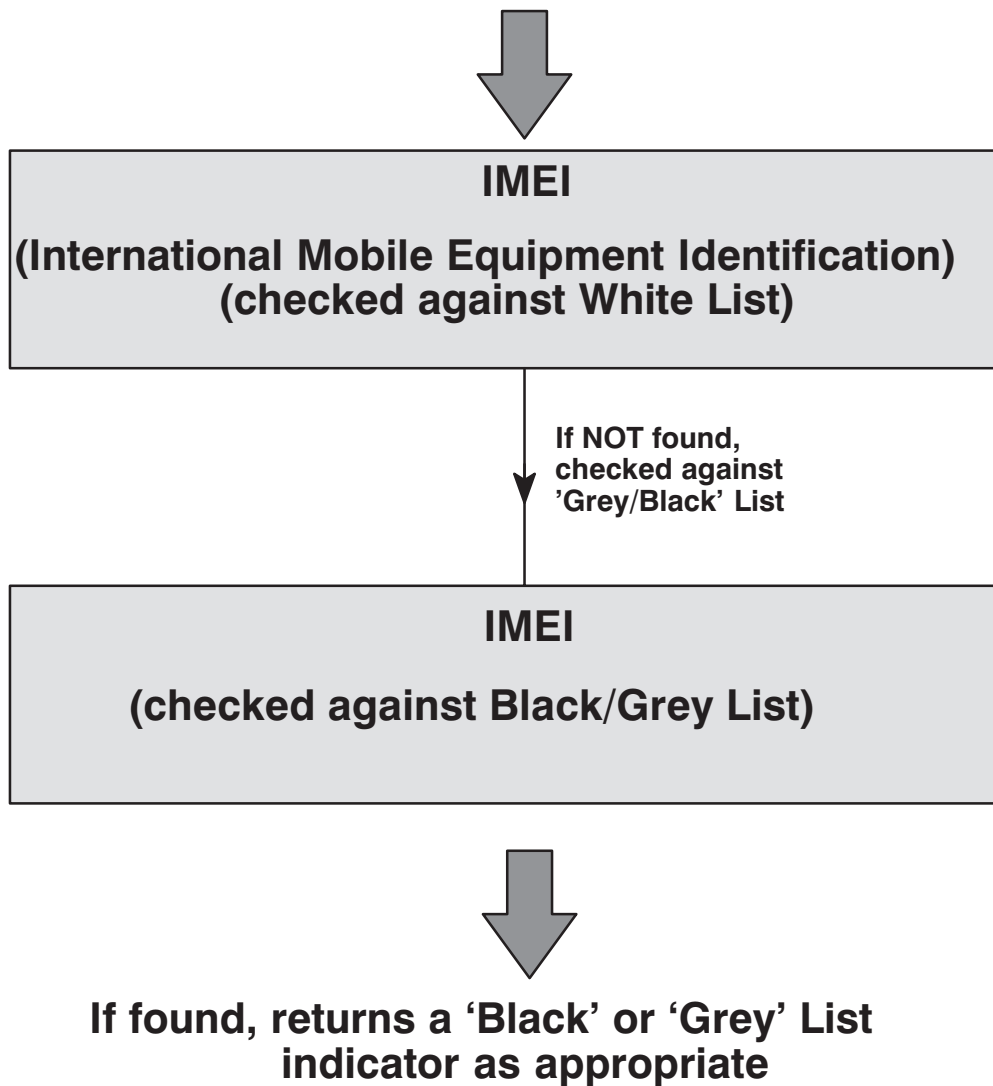

Authentication Centre (AUC)

The AUC is a processor system, it performs the “authentication” function.

It will normally be co-located with the Home Location Register (HLR) as it will be required to continuously access and update, as necessary, the system subscriber records. The AUC/HLR centre can be co-located with the MSC or located remote from the MSC.

The authentication process will usually take place each time the subscriber “initializes” on the system.

Authentication Process

To discuss the authentication process we will assume that the VLR has all the information required to perform that authentication process (Kc, SRES and RAND). If this information is unavailable, then the VLR would request it from the HLR/AUC.

1. Triples (Kc, SRES and RAND) are stored at the VLR.
2. The VLR sends RAND via the MSC and BSS, to the MS (unencrypted).
3. The MS, using the A3 and A8 algorithms and the parameter Ki stored on the MS SIM card, together with the received RAND from the VLR, calculates the values of SRES and Kc.
4. The MS sends SRES unencrypted to the VLR
5. Within the VLR the value of SRES is compared with the SRES received from the mobile. If the two values match, then the authentication is successful.
6. If cyphering is to be used, Kc from the assigned triple is passed to the BTS.
7. The mobile calculates Kc from the RAND and A8 and Ki on the SIM.
8. Using Kc, A5 and the GSM hyperframe number, encryption between the MS and the BSS can now occur over the air interface.

Note: The triples are generated at the AUC by:

RAND	=	Randomly generated number.
SRES	=	Derived from A3 (RAND, Ki).
Kc	=	Derived from A8 (RAND, Ki).
A3	=	From 1 of 16 possible algorithms defined on allocation of IMSI and creation of SIM card.
A8	=	From 1 of 16 possible algorithms defined on allocation of IMSI and creation of SIM card.
Ki	=	Authentication key, assigned at random together with the versions of A3 and A8.

The first time a subscriber attempts to make a call, the full authentication process takes place.

However, for subsequent calls attempted within a given system control time period, or within a single system provider’s network, authentication may not be necessary, as the data generated during the first authentication will still be available.

Authentication Process

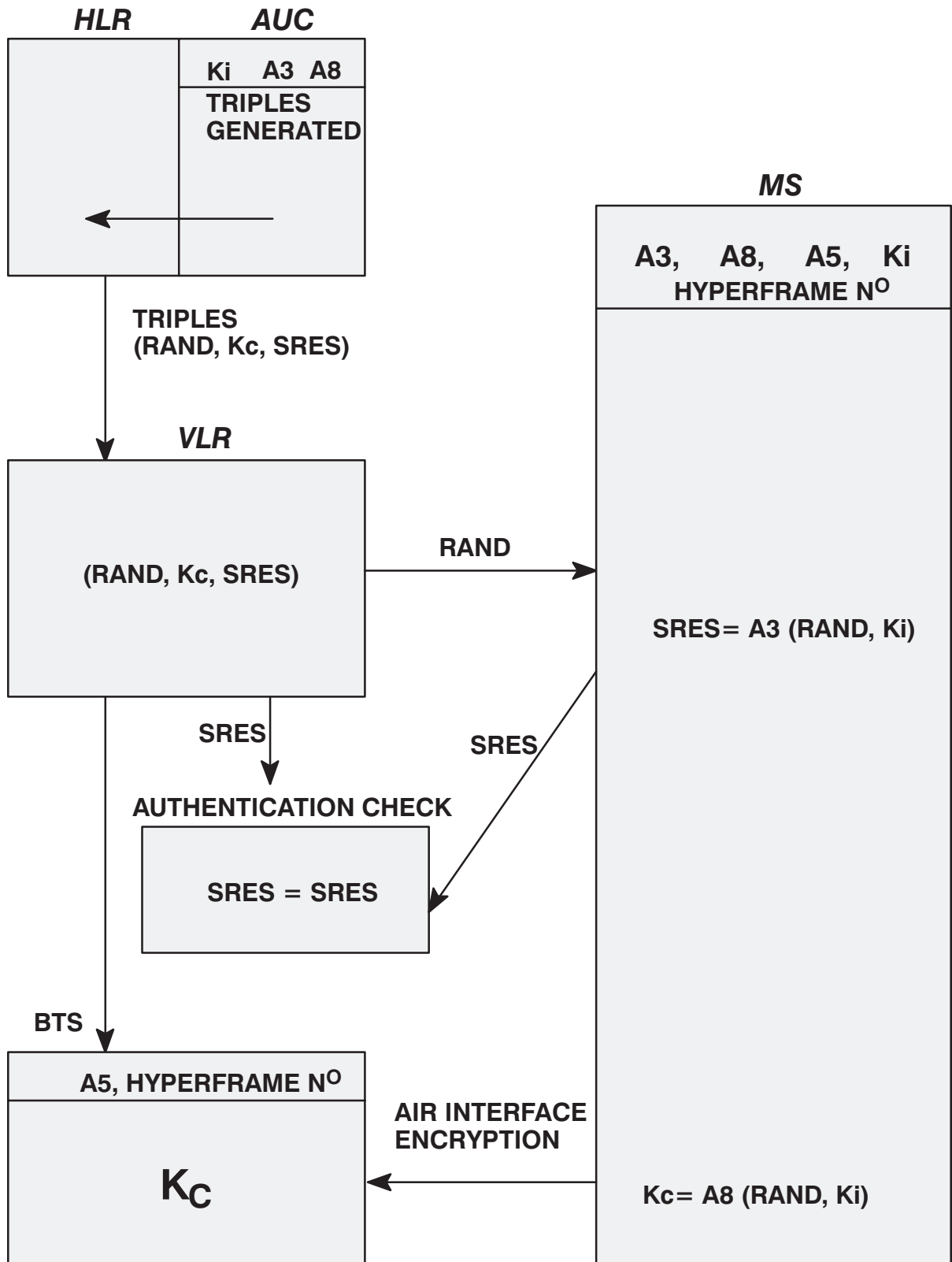

Interworking Function (IWF)

The IWF provides the function to enable the GSM system to interface with the various forms of public and private data networks currently available.

The basic features of the IWF are listed below.

- Data rate adaption.
- Protocol conversion.

Some systems require more IWF capability than others, this depends upon the network to which it is being connected.

The IWF also incorporates a “modem bank”, which may be used when, for example, the GSM **Data Terminal Equipment (DTE)** exchanges data with a land DTE connected via an analogue modem.

Interworking Function

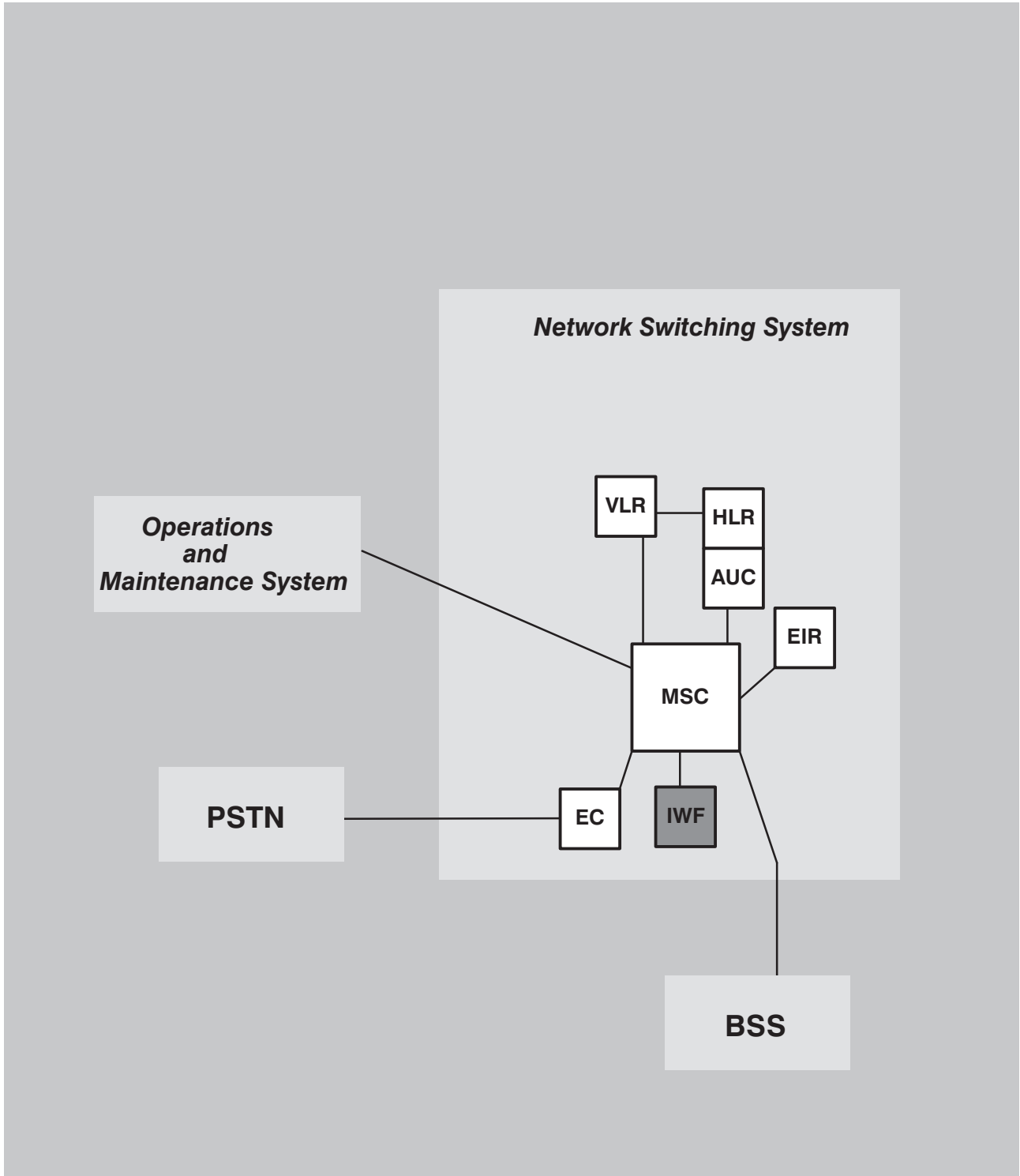

Echo Cancellor (EC)

An EC is used on the PSTN side of the MSC for all voice circuits. Echo control is required at the switch because the inherent GSM system delay can cause an unacceptable echo condition, even on short distance PSTN circuit connections.

The total round trip delay introduced by the GSM system (the cumulative delay caused by call processing, speech encoding and decoding etc) is approximately 180 mS. This would not be apparent to the MS subscriber, but for the inclusion of a 2-wire to 4-wire hybrid transformer in the circuit. This is required at the land party's local switch because the standard telephone connection is 2-wire. The transformer causes the echo. This does not affect the land subscriber.

During a normal PSTN land to land call, no echo is apparent because the delay is too short and the user is unable to distinguish between the echo and the normal telephone "side tone". However, without the EC and with the GSM round trip delay added, the effect would be very irritating to the MS subscriber, disrupting speech and concentration.

The standard EC will provide cancellation of up to 68 milliseconds on the "tail circuit" (the tail circuit is the connection between the output of the EC and the land telephone).

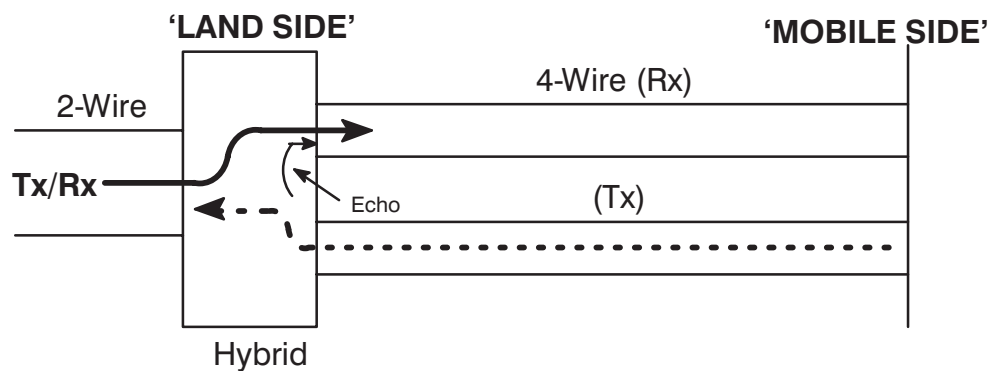

Generation of Echoes at 2-Wire to 4-Wire interface

Echo Celler

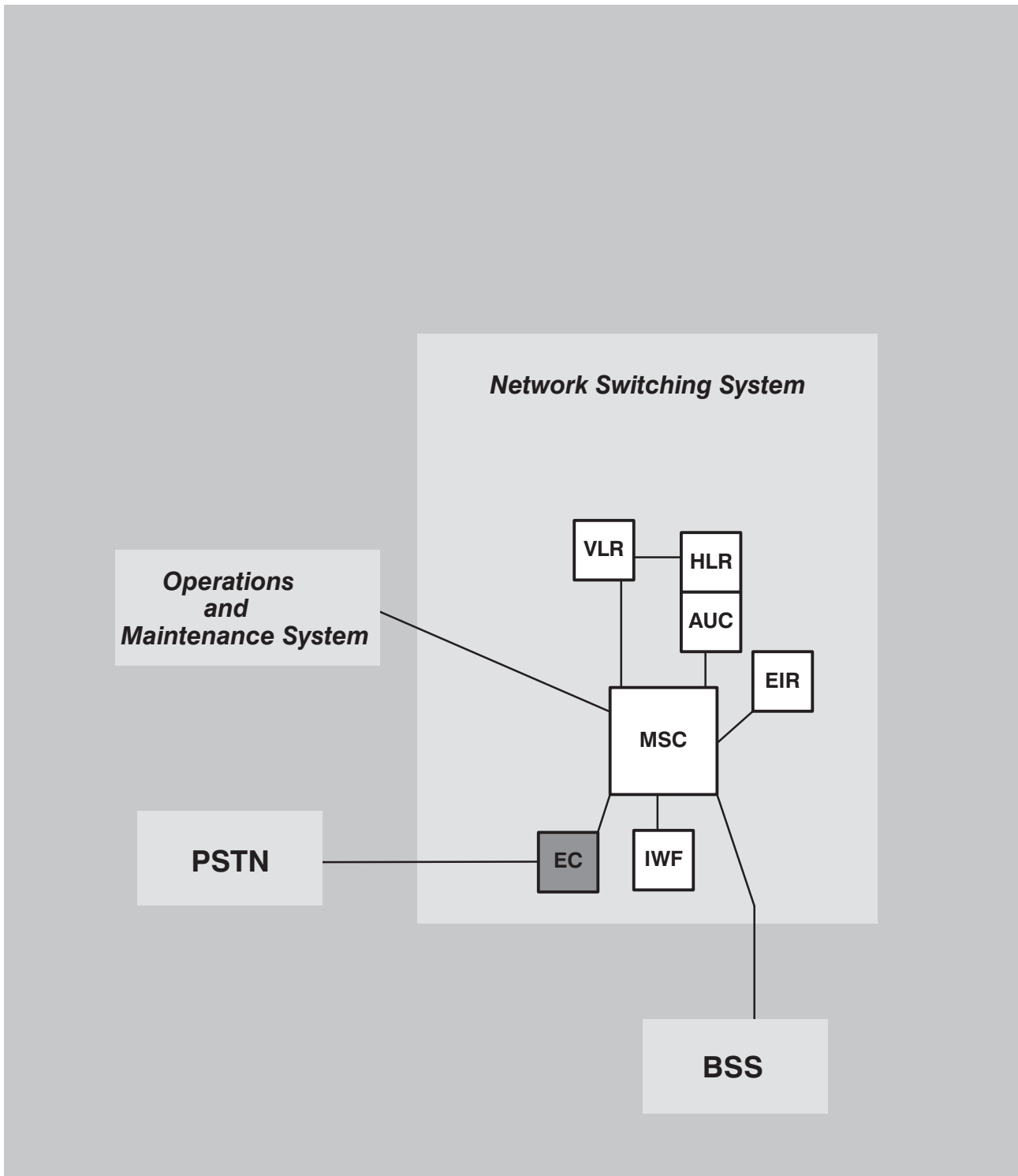

Operations and Maintenance System

Overview

The operations and maintenance system provides the capability to manage the GSM network remotely.

This area of the GSM network is not currently tightly specified by the GSM specifications, it is left to the network provider to decide what capabilities they wish it to have. The Operations and Maintenance System comprises of two parts:

Network Management Centre (NMC)

The Network Management Centre (NMC) has a view of the entire PLMN and is responsible for the management of the network as a whole. The NMC resides at the top of the hierarchy and provides global network management.

Operations and Maintenance Centre (OMC)

The Operations and Maintenance Centre (OMC) is a centralized facility that supports the day to day management of a cellular network as well as providing a database for long term network engineering and planning tools. An OMC manages a certain area of the PLMN thus giving regionalized network management.

Operations & Maintenance System

OMC (REGIONAL)	NMC (GLOBAL)
<p><u>Multiple</u> OMCs per network</p> <p><u>Regionalized</u> network management</p> <p>Employed in <u>daily operations</u></p> <p>Used by network <u>operators</u></p>	<p><u>Single</u> NMC per network</p> <p><u>Global</u> network management</p> <p>Employed in <u>long term planning</u></p> <p>Used by network <u>managers</u> and <u>planners</u></p> <p>24 hour <u>supervision</u></p>

Network Management Centre (NMC)

The NMC offers the ability to provide hierarchical regionalized network management of a complete GSM system.

It is responsible for operations and maintenance at the network level, supported by the OMCs which are responsible for regional network management.

The NMC is therefore a single logical facility at the top of the network management hierarchy.

The NMC has a high level view of the network, as a series of network nodes and interconnecting communications facilities. The OMC, on the other hand, is used to filter information from the network equipment for forwarding to the NMC, thus allowing it to focus on issues requiring national co-ordination. The NMC can also co-ordinate issues regarding interconnection to other networks, for example the PSTN.

The NMC can take regional responsibility when an OMC is not manned, with the OMC acting as a transit point between the NMC and the network equipment. The NMC provides operators with functions equivalent to those available at the OMC.

Functionality of the NMC
Monitors nodes on the network
Monitors GSM network element statistics
Monitors OMC regions & provides information to OMC staff
Passes on statistical information from one OMC region to another to improve problem solving strategies
Enables long term planning for the entire network

Network Management Centre

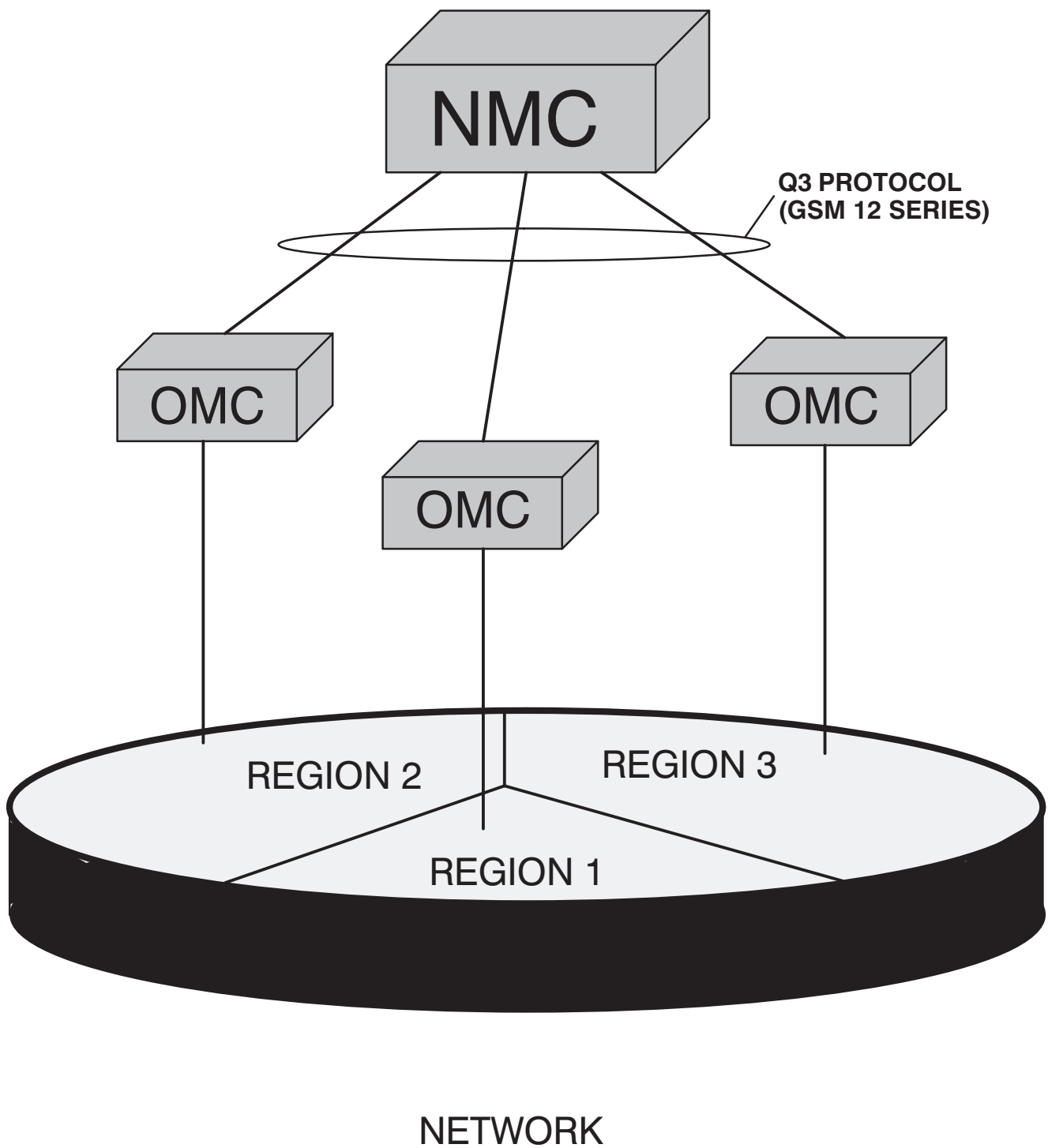

Operations and Maintenance Centre (OMC)

The OMC provides a central point from which to control and monitor the other network entities (i.e. base stations, switches, database, etc) as well as monitor the quality of service being provided by the network.

At present, equipment manufacturers have their own OMCs which are not compatible in every aspect with those of other manufacturers. This is particularly the case between radio base station equipment suppliers, where in some cases the OMC is a separate item and Digital Switching equipment suppliers, where the OMC is an integral, but functionally separate, part of the hardware.

There are two types of OMC these are:

- **OMC (R)**

OMC controls specifically the Base Station System.

- **OMC (S)**

OMC controls specifically the Network Switching System.

The OMC should support the following functions as per ITS–TS recommendations:

- Event/Alarm Management.
- Fault Management.
- Performance Management.
- Configuration Management.
- Security Management.

The OMC functional architecture is illustrated in the diagram opposite.

OMC Functional Architecture

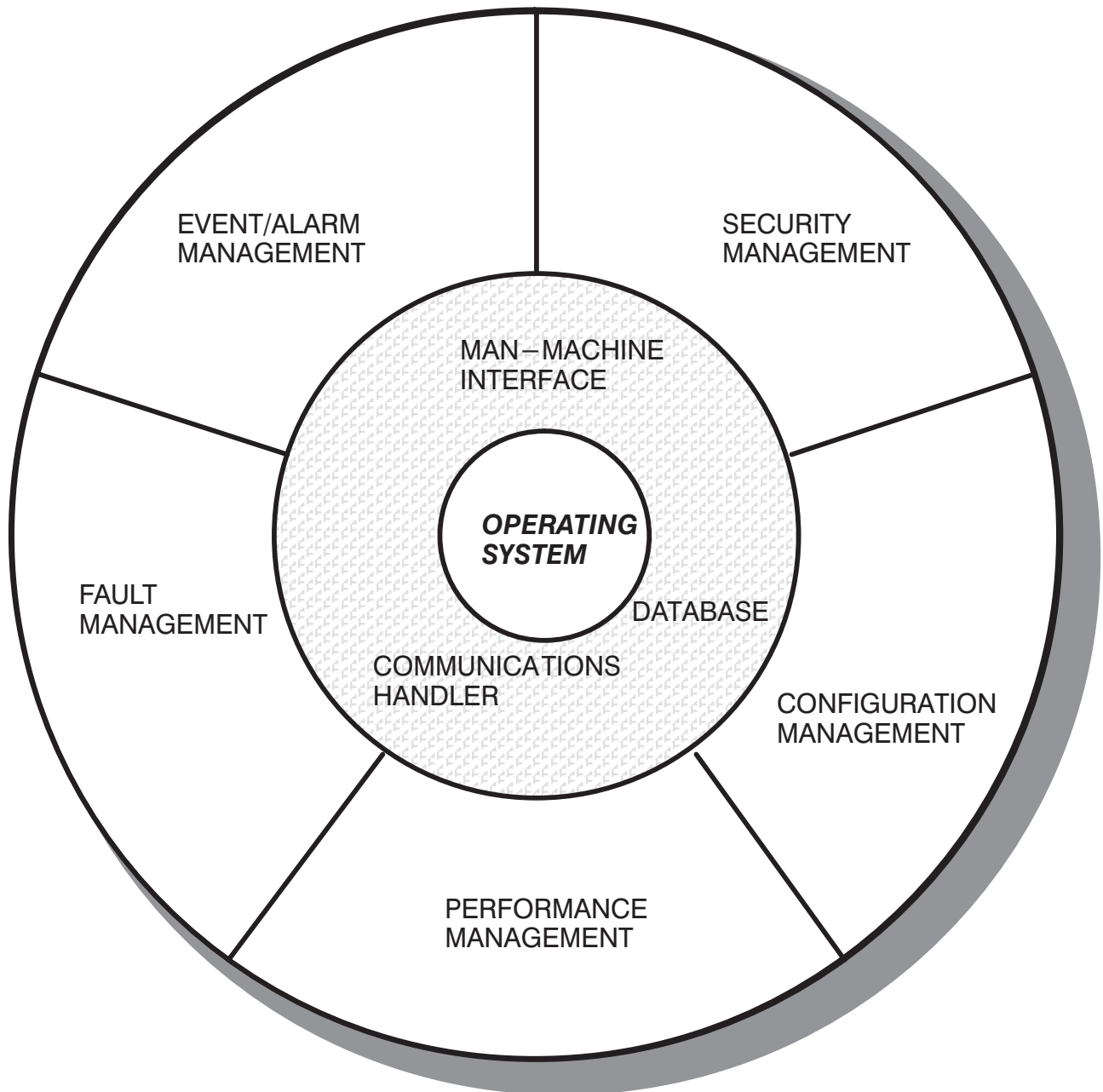

The Network In Reality

In reality a GSM network is much more complicated than we have seen. The diagram opposite illustrates how multiple BSS and Network Switching System components will be connected within a network.

A typical city (for example, London) will have approximately the following number of network components:

Network Component	Quantity
Operations and Maintenance Centre (Base Station Equipment) – OMC(R)	1
Operations and Maintenance Centre (Switching) – OMC(S)	1
Mobile Services Switching Centre – MSC/VLR	1–2
Base Station Controller – BSC	5–15
Base Transceiver Station – BTS	200–400

A typical network (for example, UK) will have approximately the following number of network components.

Network Component	Quantity
Operations and Maintenance Centre (Base Station Equipment) – OMC(R)	6
Operations and Maintenance Centre (Switching) – OMC(S)	6
Mobile Services Switching Centre – MSC/VLR	6
Base Station Controller – BSC	40+
Base Transceiver Station – BTS	1200+

GSM Network Components

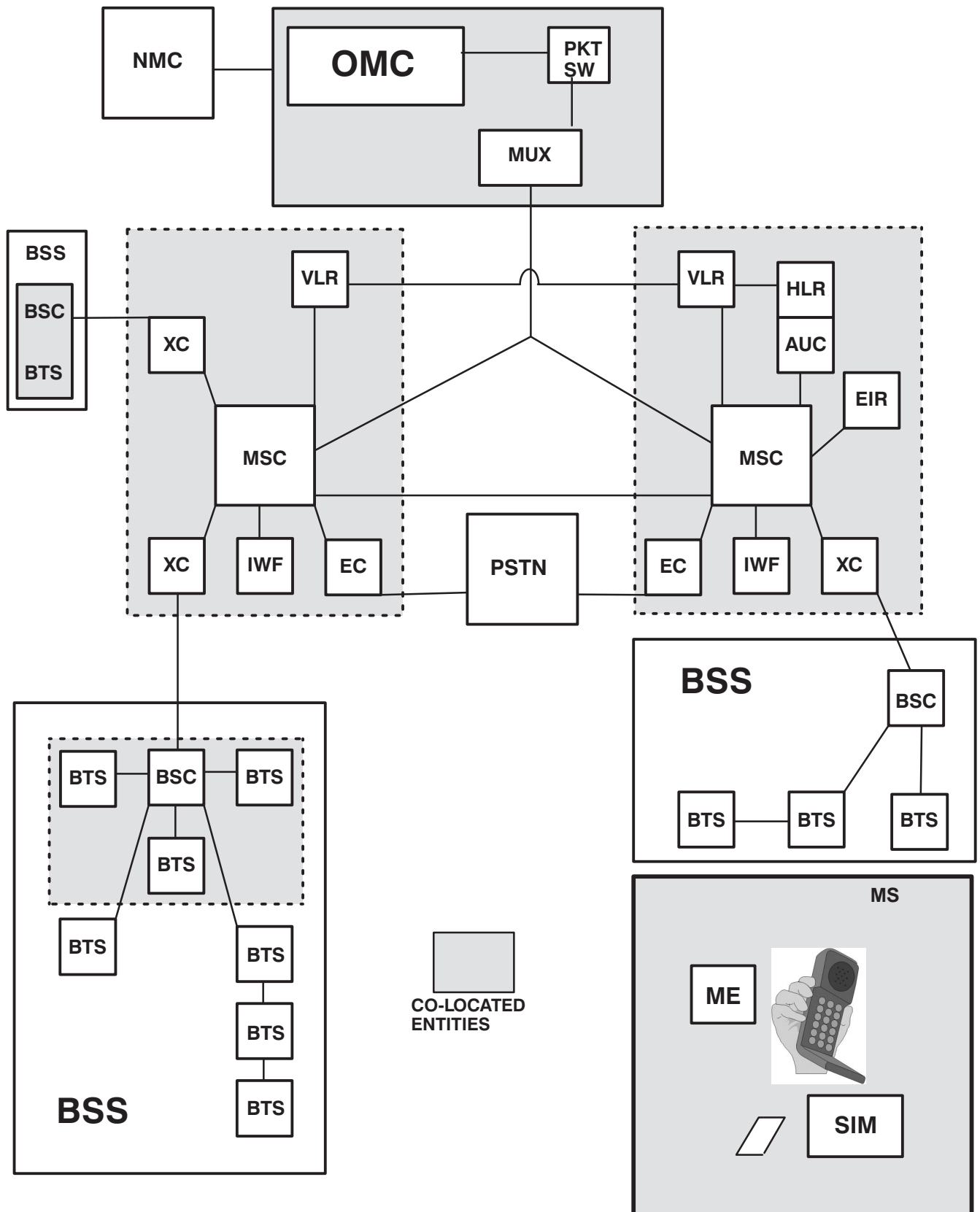

Chapter 4

GSM Terrestrial Interfaces

Chapter 4	
GSM Terrestrial Interfaces	i
GSM Terrestrial Interfaces	4-1
Section Objectives	4-1
Introduction	4-2
2 Mbit/s Trunk 30-channel PCM	4-4
X.25 Interfaces	4-6
ITU-TS Signalling System #7	4-8
A-bis (LAPD) Interfaces	4-10
Interconnections	4-12
Interface Names	4-14

GSM Terrestrial Interfaces

Section Objectives

On completion of this course the student will be able to:

- Identify the protocols used on the terrestrial interfaces between the GSM system entities.

Introduction

The *terrestrial interfaces* comprise all the connections between the GSM system entities, apart from the Um, or air interface.

They are represented on the diagram opposite by the lines that connect the various entities together.

The GSM terrestrial interfaces and message-transport mediums all conform to ITU-TSS specifications widely used throughout the world. As we stated previously, it is from this use of standardized interfaces that the flexibility of GSM largely derives.

The terrestrial interfaces transport the traffic across the system and allow the passage of the thousands of data messages necessary to make the system function. They transport the data for software downloads and uploads, the collection of statistical information and the implementation of operations and maintenance commands.

The standard interfaces used are as follows:

- 2 Mbit/s.
- Signalling System ITU-TSS #7 ("C7" or "SS#7").
- X.25 (packet switched data); (LAPB).
- A bis using the LAPD protocol (Link Access Procedure "D").

Whatever the interfaces and whatever their function, they will often share a common physical bearer (cable) between two points, for example, the MSC and a BSS.

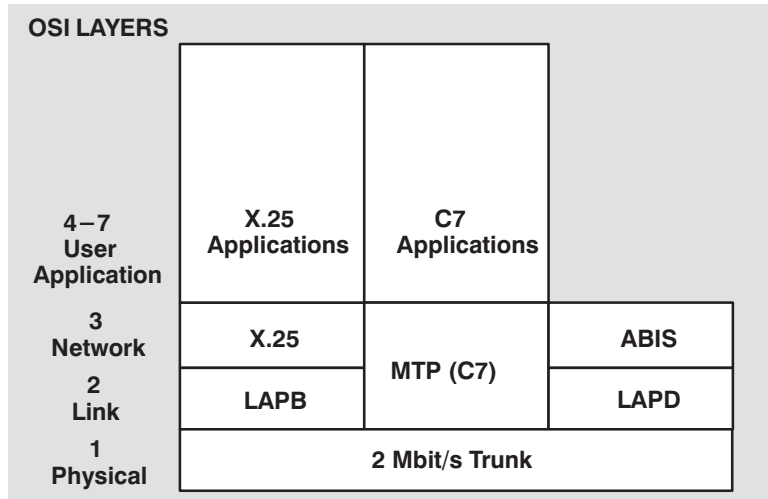

The GSM System

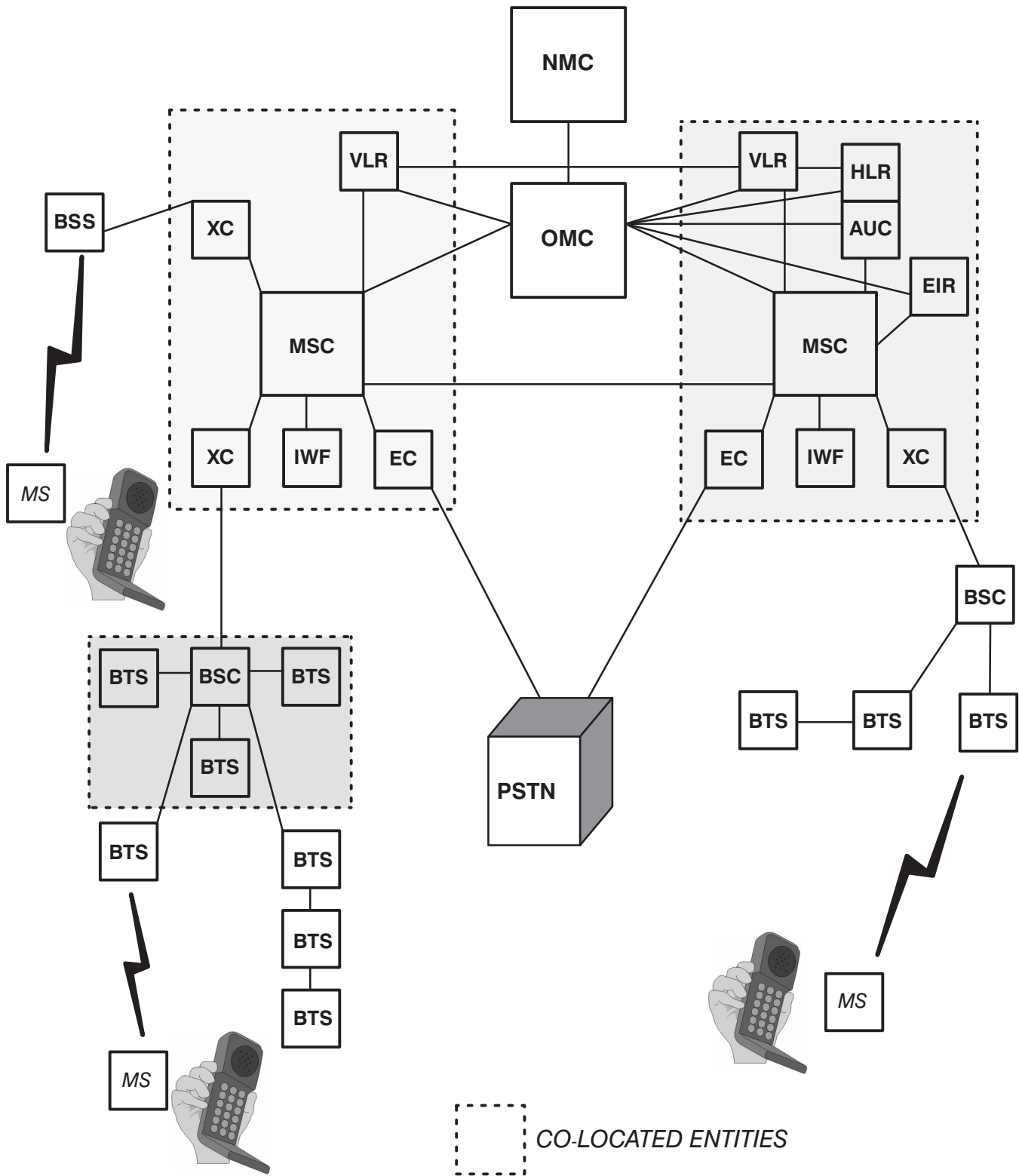

2 Mbit/s Trunk 30-channel PCM

This diagram opposite shows the logical GSM system with the 2 Mbit/s interfaces highlighted. They carry traffic from the PSTN to the MSC, between MSCs, from an MSC to a BSC and from a BSC to remotely sited BTSs. These links are also used between the MSC and IWF.

Each 2.048 Mbit/s link provides thirty 64 kbit/s channels available to carry speech, data, or control information.

The control information may contain C7, LAPD or X.25 formatted information.

These 2 Mbit/s links commonly act as the physical bearer for the interfaces used between the GSM system entities.

Typical Configuration

TS 0	TS 1–15	TS16	TS 17–31
------	---------	------	----------

TS#	Used for
0	Frame Alignment/ Error Checking/ Signalling/ Alarms
1–15	Traffic
16	Signalling (other TS may also be used)
17–31	Traffic

TS = Timeslot

2 Mbit/s Trunks

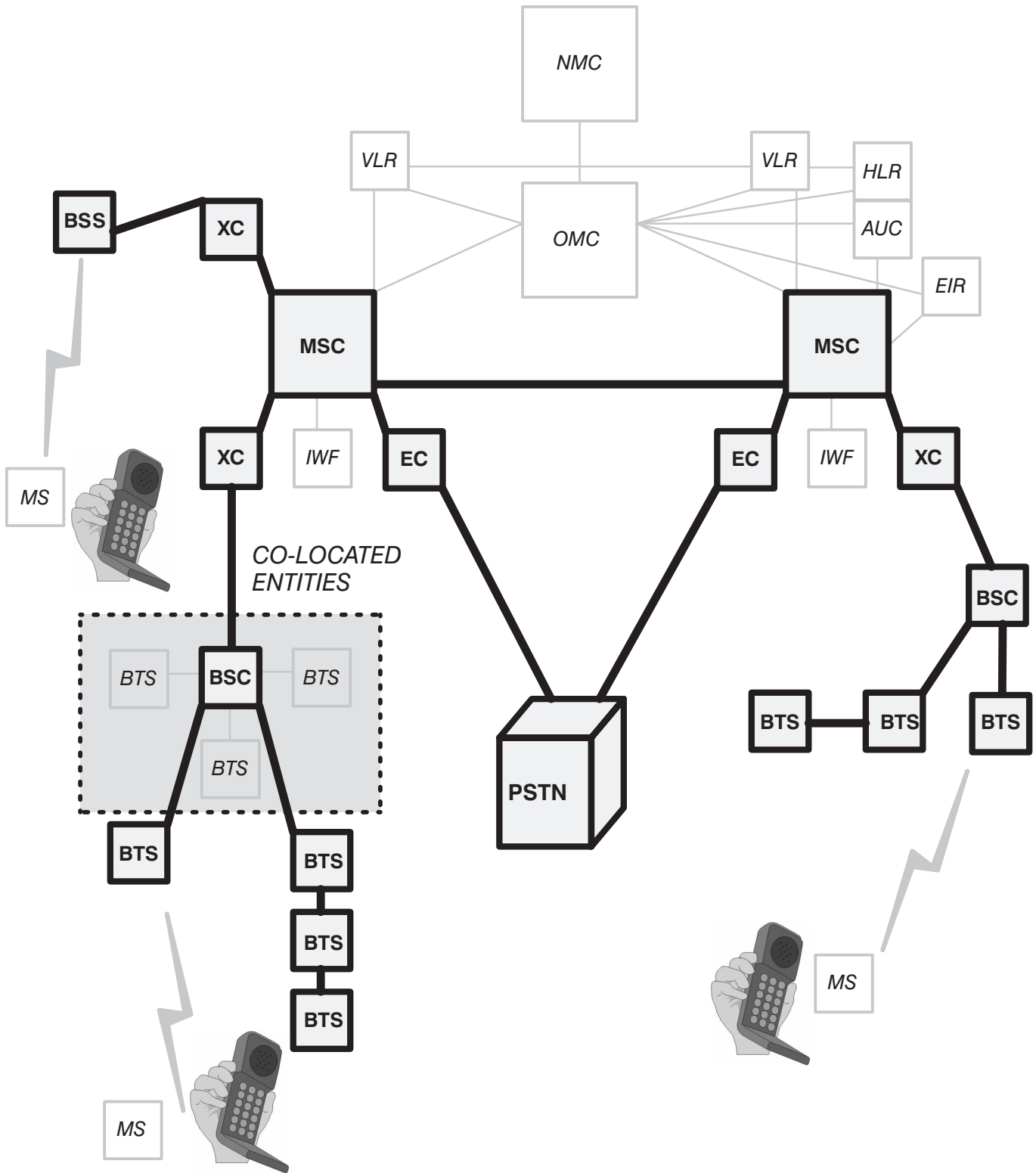

X.25 Interfaces

The diagram opposite shows the X.25 packet data connections of the system.

The X.25 packets provide the OMC with communications to all the entities over which it has control and oversight. Remember that these X.25 connections will commonly be contained within 2 Mbit/s links using a dedicated timeslot.

Note that the X.25 connection from the OMC to the BSS may be "nailed through" (or permanently connected by software) at the MSC, or may be supported by a completely independent physical route.

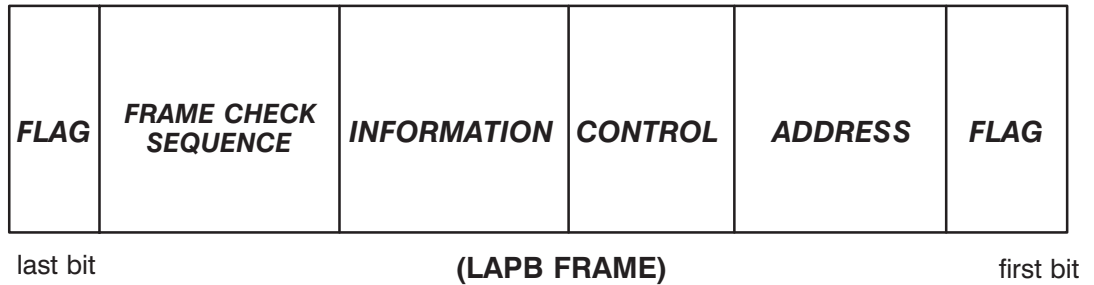

X.25 Interfaces

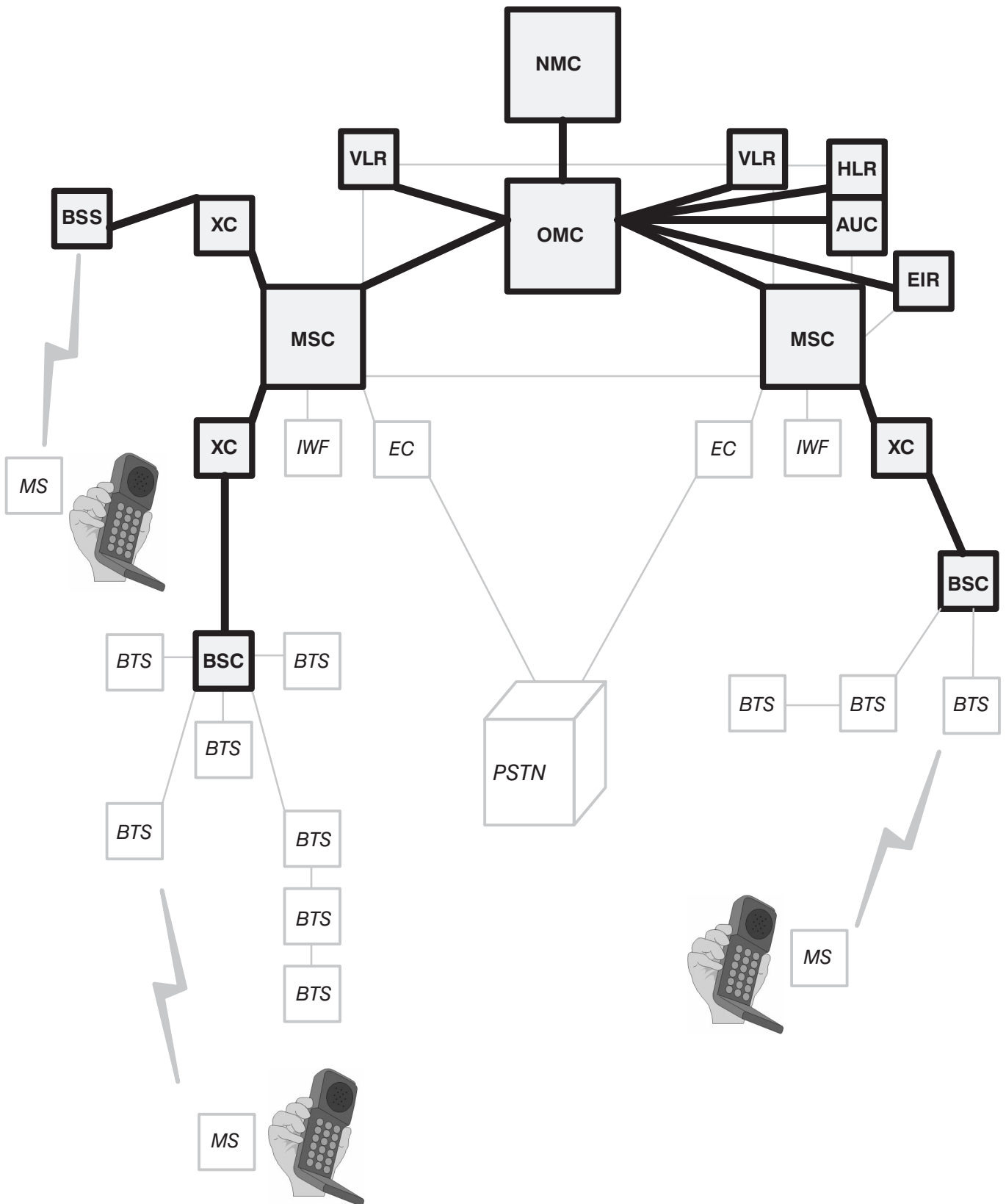

ITU-TS Signalling System #7

The diagram opposite illustrates the use of C7 in the GSM system; carrying signalling and control information between most major entities, and to and from the PSTN.

The following message protocols, which are part of C7, are used to communicate between the different GSM network entities:

- Interfacing the PSTN, the MSC performs call signalling functions using the Telephone User Part (TUP), or interfacing the ISDN, the ISDN User Part (ISUP).
- Between the MSC and the BSC, the Base Station System Management Application Part (BSSMAP) is used. The Direct Transfer Application Part (DTAP) is used to send messages between the MSC and the mobile (MS). MAP is used between the MSC and the VLR, EIR, and HLR.

Acronyms:

BSSAP	Base Station System Application Part
BSSMAP	Base Station System Management Application Part
DTAP	Direct Transfer Application Part
ISUP	ISDN User Part
MAP	Mobile Application Part
SCCP	Signalling Connection Control Part
TUP	Telephone User Part
TCAP	Transaction Capabilities Application Part

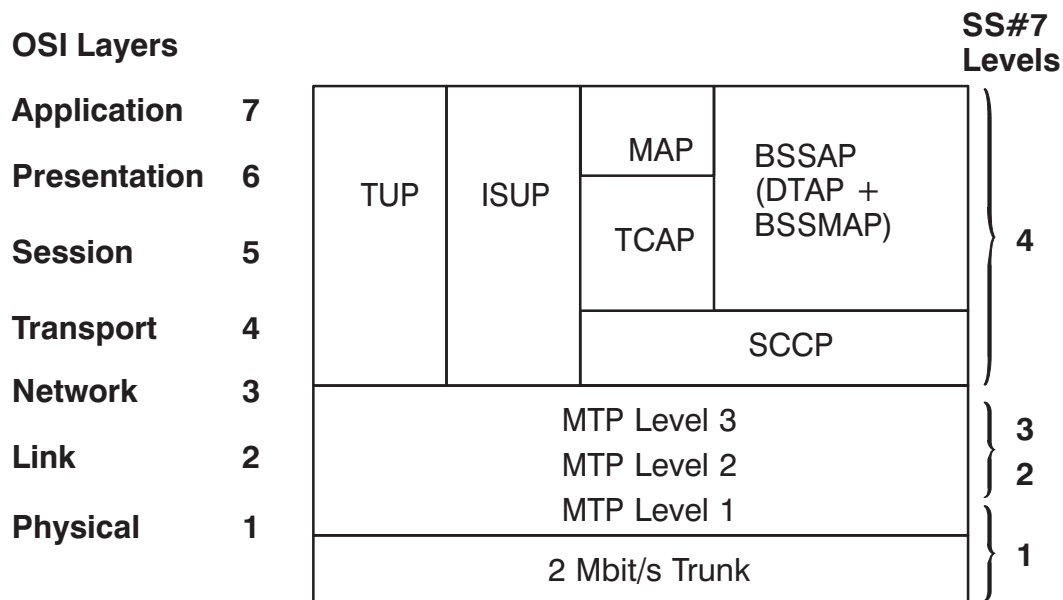

C7 Interfaces

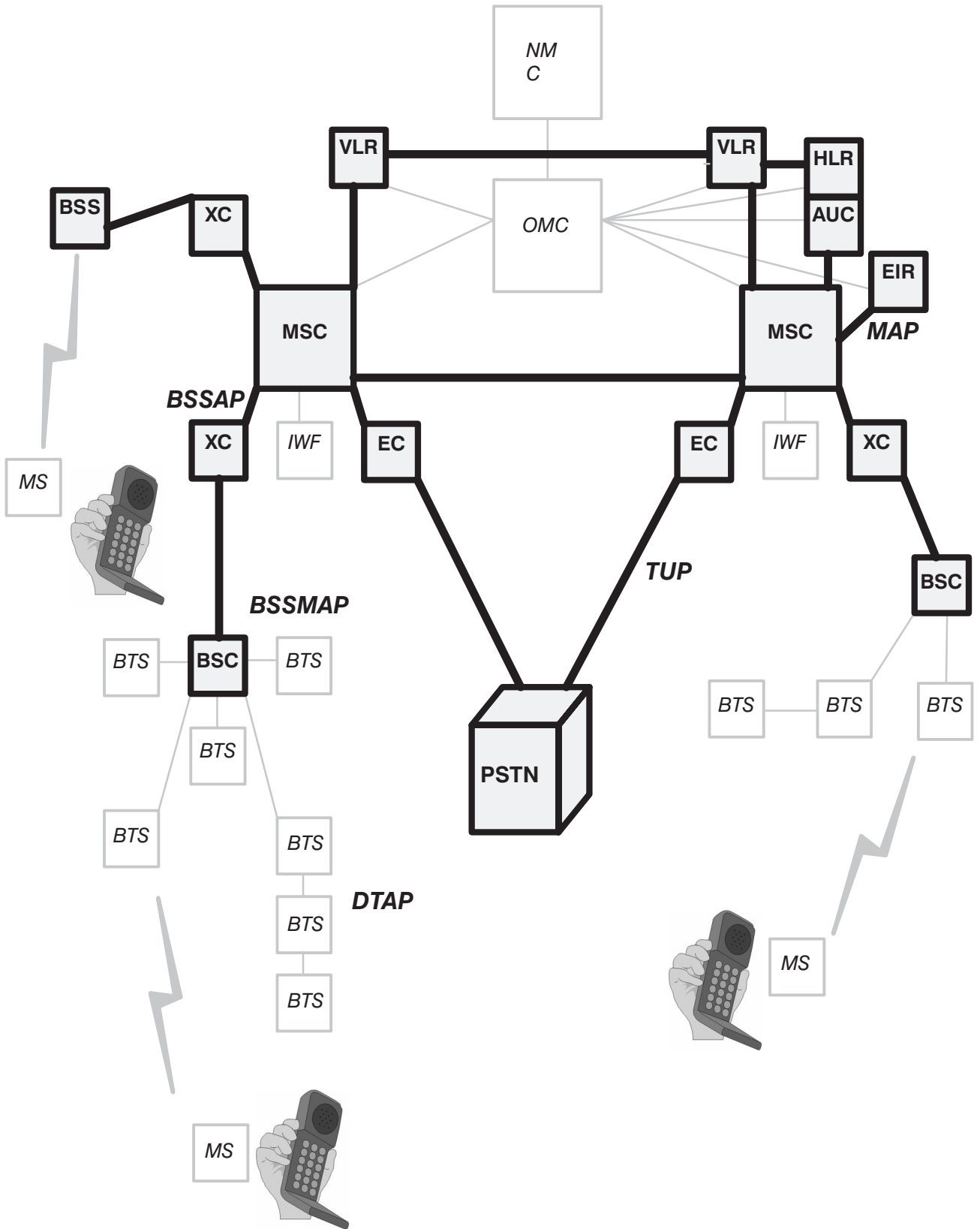

A-bis (LAPD) Interfaces

Because of the specific nature of the signalling and control information passing over the 2 Mbit/s links between the BSC and remotely sited BTS, a different type of interface is required. GSM has specified the use of LAPD. This protocol uses the standard frame structure shown below.

The GSM specifications for this interface (termed "A-bis") are not very specific and therefore interpretations of the interface vary. This means that one manufacturer's BTS will not work with another manufacturer's BSC. As we have already mentioned, the functionality split between the BTS and BSC is also largely in the hands of the manufacturer and therefore it is unlikely that they would operate together, even if this interface were rigidly enforced by the specifications.

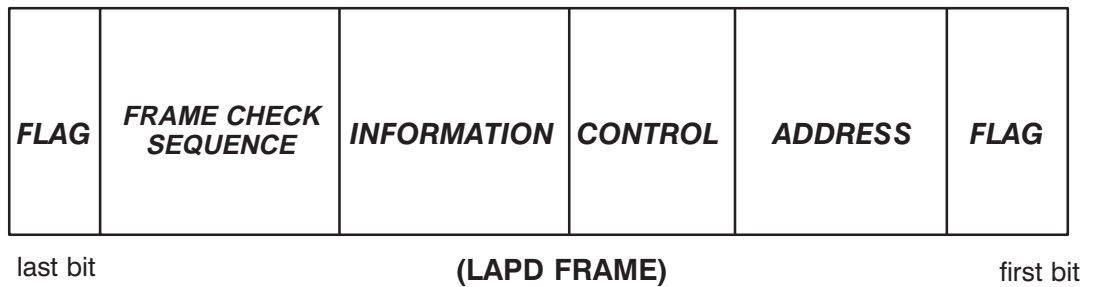

A-bis (LAPD) Interfaces

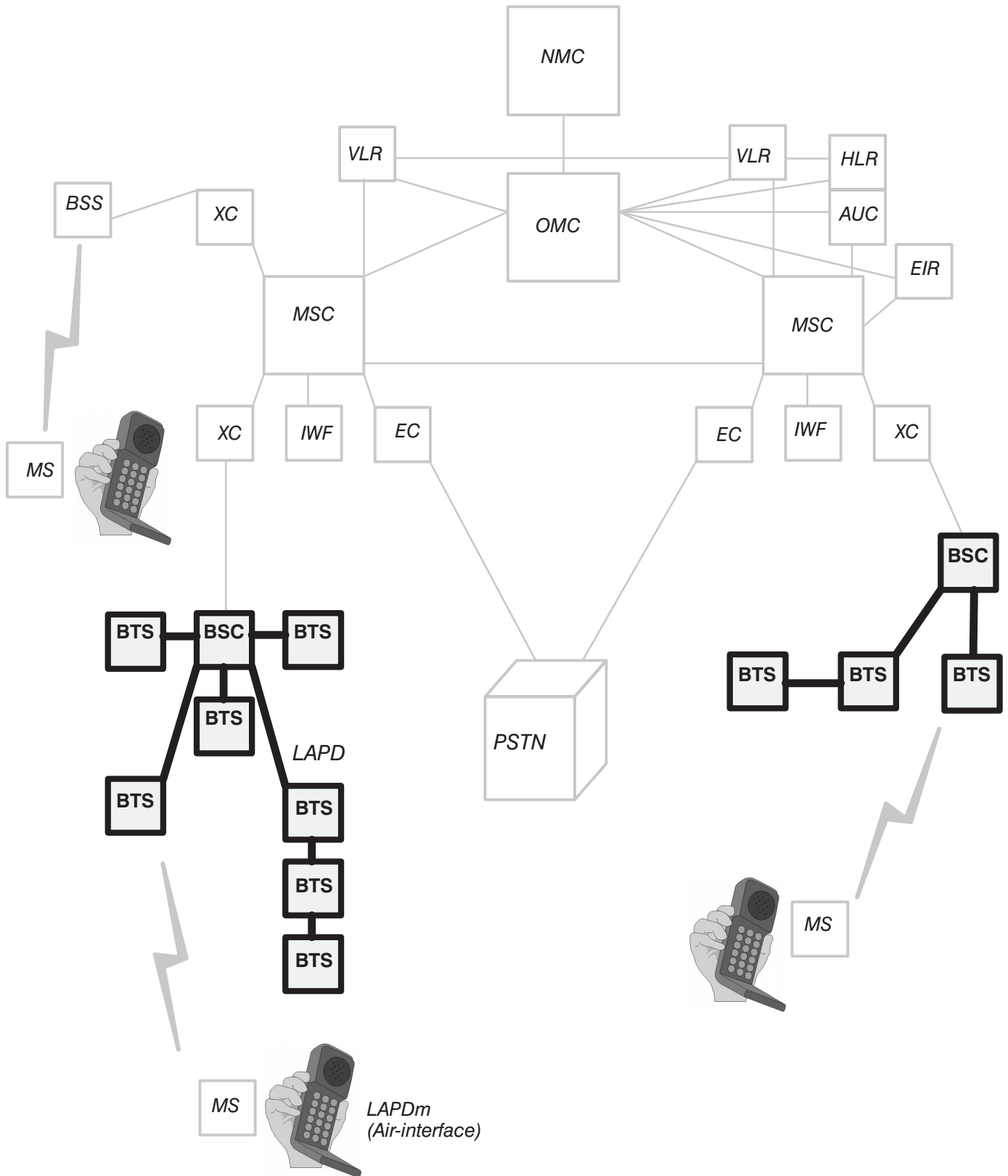

Interconnections

The interface between the BSC and the MSC is a standardized ITU-TSS signalling system N⁰⁷ (C7) interface, referred to as the A interface.

The interface supports the following connections:

- BSC–MSC, BSC–BTS and MSC–MS.
- Operation and Maintenance interface.
- All call processing functions.

These interfaces are commonly transported on a physical bearer, the 2 Mbit/s link.

Each of these 2 Mbit/s links provide 32 x 64 kbit/s channels (timeslots), the first channel (TS0) is used for frame alignment, leaving 31 channels available for carry “traffic channels” or “signalling interfaces”.

The signalling protocols used between GSM networks are:

- X.25 (LAPB), 1 x 64 kbit/s timeslot.
- C7 (SS7), 1 x 64 kbit/s timeslot (BSSAP, MAP, TCAP, SCCP, MTP).
- LAPD, 1 x 64 kbit/s timeslot.

The X.25 protocol is used between the BSC–OMC.

The C7 link is between the BSC–MSC, dependent on what type of signalling is required will depend on which part of the C7 protocol will be used (for example, MSC–MS will use a subset of BSSAP called DTAP to transfer messages).

The LAPD protocol is used between the BSC–BTS, this is normally 64 kbit/s as stated but some manufactures offer 16 kbit/s links as well.

The link between the BSC–CBC does not use a specified protocol. The choice of protocol is decided between the PLMN provider and the CBC provider. (Typically X.25 or C7 may be used.)

BSC Connections

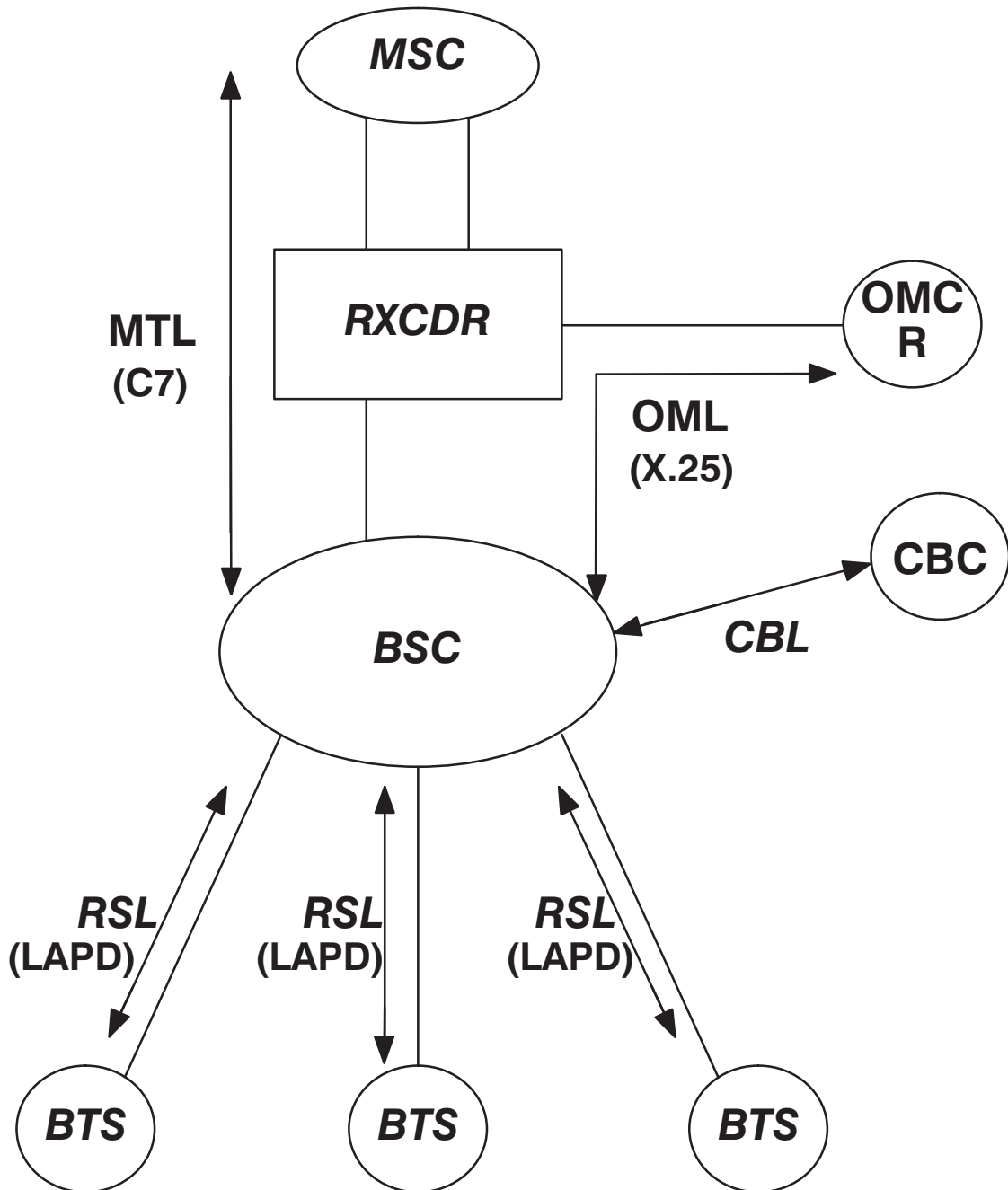

Interface Names

Each interface specified within the GSM system has a name associated with it. The diagram opposite illustrates the names of all the interfaces specified by GSM.

Name	Interface
Um	MS ↔ BTS
A-bis	BTS ↔ BSC
A	BSC ↔ MSC
B	MSC ↔ VLR
C	MSC ↔ HLR
D	VLR ↔ HLR
E	MSC ↔ MSC
F	MSC ↔ EIR
G	VLR ↔ VLR
H	HLR ↔ AUC

The GSM System Interface Names

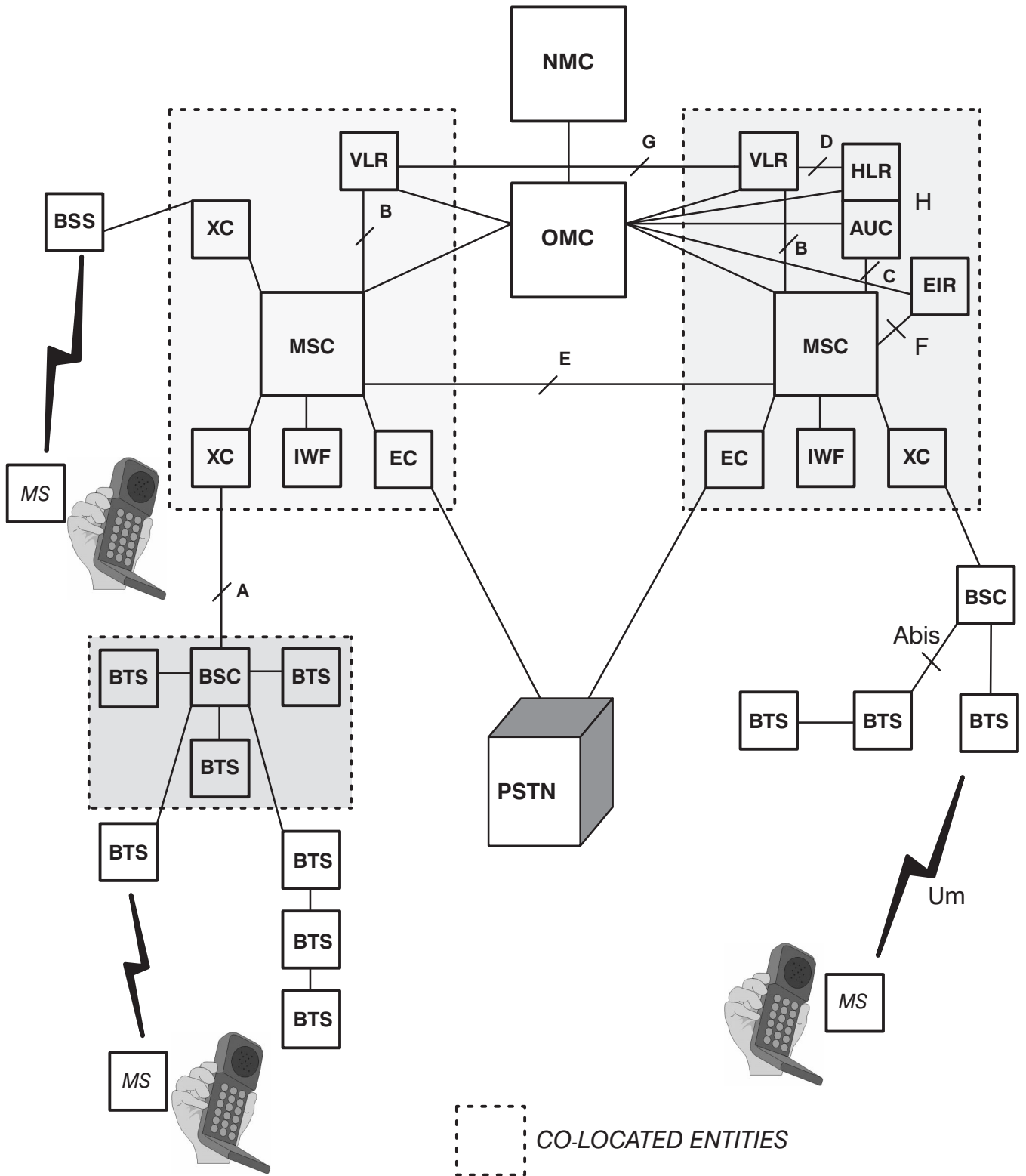

Chapter 5

Channels on the Air Interface

Chapter 5	
Channels on the Air Interface	i
Channels on the Air Interface	5-1
Section Objectives	5-1
Transmission of Analogue and Digital Signals	5-2
Modulation Techniques	5-2
Transmission of Digital Signals	5-4
Phase Shift Keying (PSK)	5-4
Gaussian Minimum Shift Keying (GMSK)	5-4
Physical and Logical Channels	5-6
GSM Physical Channels	5-6
GSM Logical Channels	5-8
Traffic Channels (TCH)	5-8
GSM Control Channel Groups	5-10
BCCH Group	5-10
CCCH Group	5-10
DCCH Group	5-10
GSM Logical Channels	5-12
Control Channels	5-12
Channel Combinations	5-18
Channel Combinations and Timeslots	5-18
Multiframes and Timing	5-20
The 26-frame Traffic Channel Multiframe	5-20
The 51-frame Control Channel Multiframe	5-22
The 51-frame Control Channel Multiframe (BCCH/CCCH)	5-24
The 51-frame Control Channel Multiframe – DCCH/8 (SDCCH and SACCH) ..	5-26
The 51-frame Control Channel Multiframe – Combined Structure	5-28
Superframes and Hyperframes	5-30
Mobile Activity – Transmit and Receive Timeslots	5-32
Overview	5-32
GSM Basic Call Sequence	5-34

Channels on the Air Interface

Section Objectives

On completion of this section the student will be able to:

- Understand why GMSK is used to modulate the GSM signal.
- Name the four most commonly used channel combinations and provide reasons why each would be used.
- State the reason why multiframes, superframes and hyperframes are utilized.

Transmission of Analogue and Digital Signals

The main reasons why GSM uses a digital air interface:

- It is “noise robust”, enabling the use of tighter frequency re-use patterns and minimizing interference problems;
 - It incorporates error correction, thus protecting the traffic that it carries;
 - It offers greatly enhanced privacy to subscribers and security to network providers;
 - It is ISDN compatible, uses open standardized interfaces and offers an enhanced range of services to its subscribers.
-

Modulation Techniques

There are three methods of modulating a signal so that it may be transmitted over the air:

- **Amplitude Modulation (AM)**
Amplitude Modulation is very simple to implement for analogue signals but it is prone to noise.
- **Frequency Modulation (FM)**
Frequency Modulation is more complicated to implement but provides a better tolerance to noise.
- **Phase Modulation (PM)**
Phase Modulation provides the best tolerance to noise but it is very complex to implement for analogue signals and therefore is rarely used.

Digital signals can use any of the modulation methods, but phase modulation provides the best noise tolerance. Since phase modulation can be implemented easily for digital signals, this is the method which is used for the GSM air interface. Phase Modulation is known as Phase Shift Keying (PSK) when applied to digital signals.

Modulation Techniques

1. **Amplitude Modulation (AM)**
2. **Frequency Modulation (FM)**
3. **Phase Shift Keying (PSK)**

Transmission of Digital Signals

Phase Shift Keying (PSK)

Phase modulation provides a high degree of noise tolerance. However, there is a problem with this form of modulation. When the signal changes phase abruptly, high frequency components are produced, thus a wide bandwidth would be required for transmission.

GSM has to be as efficient as possible with the available bandwidth. Therefore, it is not this technique, but a more efficient development of phase modulation that is actually used by the GSM air interface, it is called Gaussian Minimum Shift Keying (GMSK).

Gaussian Minimum Shift Keying (GMSK)

With GMSK, the phase change which represents the change from a digital '1' or a '0' does not occur instantaneously as it does with Binary Phase Shift Keying (BPSK). Instead it occurs over a period of time and therefore the addition of high frequency components to the spectrum is reduced.

With GMSK, first the digital signal is filtered through a Gaussian filter. This filter causes distortion to the signal, the corners are rounded off. This distorted signal is then used to phase shift the carrier signal. The phase change therefore is no longer instantaneous but spread out.

Frequency Spectrum

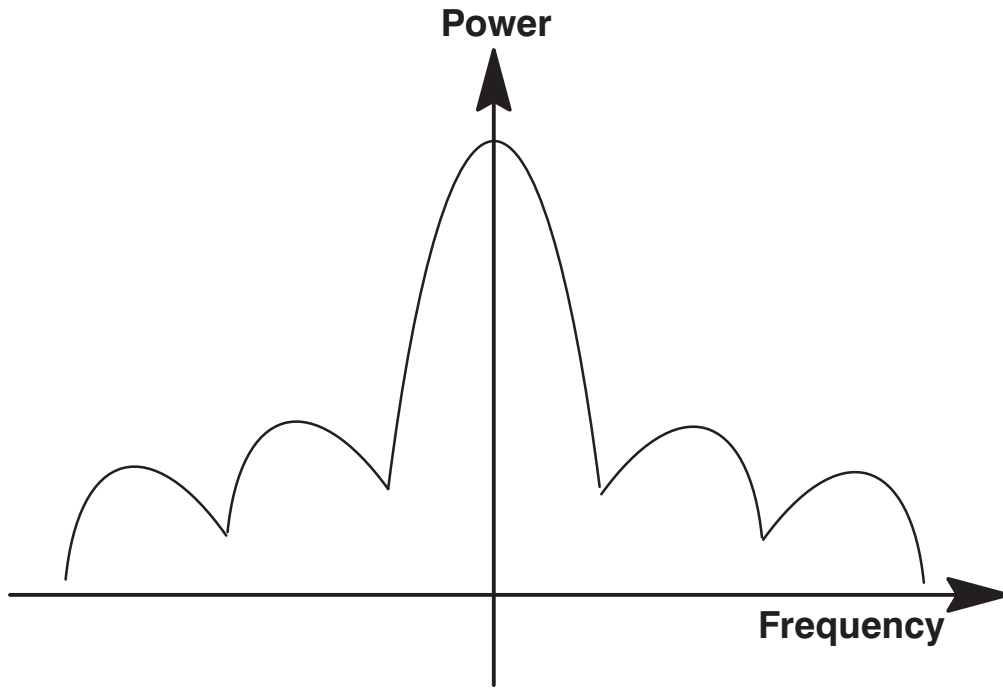

Gaussian Minimum Shift Keying (GMSK)

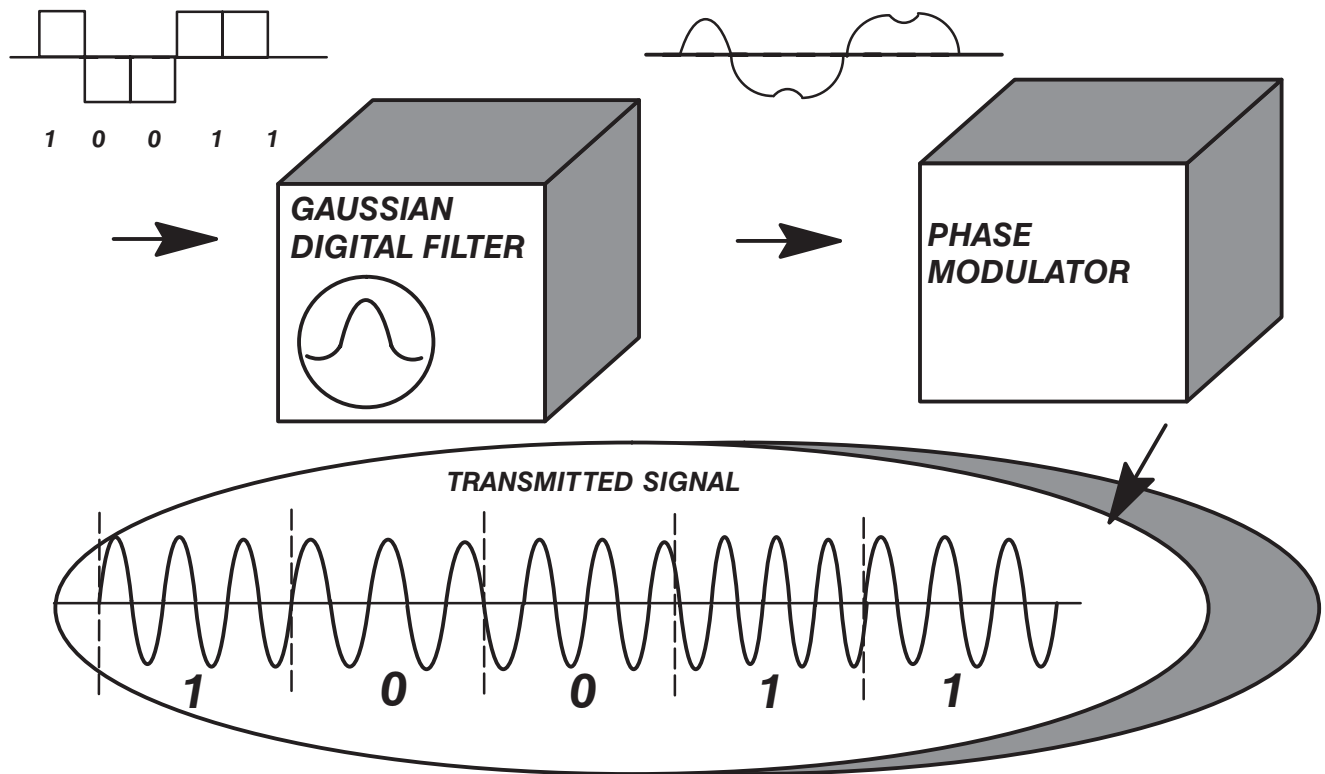

Physical and Logical Channels

The physical channel is the medium over which the information is carried, in the case of a terrestrial interface this would be a cable. The logical channels consist of the information carried over the physical channel.

GSM Physical Channels

A single GSM RF carrier can support up to eight MS subscribers simultaneously. The diagram opposite shows how this is accomplished. Each channel occupies the carrier for one eighth of the time. This is a technique called *Time Division Multiple Access*.

Time is divided into discrete periods called "*timeslots*". The timeslots are arranged in sequence and are conventionally numbered 0 to 7. Each repetition of this sequence is called a "TDMA frame".

Each MS telephone call occupies one timeslot (0–7) within the frame until the call is terminated, or a handover occurs. The TDMA frames are then built into further frame structures according to the type of channel. We shall later examine how the information carried by the air interface builds into frames and multi-frames and discuss the associated timing.

For such a system to work correctly, the timing of the transmissions to and from the mobiles is critical. The MS or Base Station must transmit the information related to one call at exactly the right moment, or the timeslot will be missed. The information carried in one timeslot is called a "*burst*".

Each data burst, occupying its allocated timeslot within successive TDMA frames, provides a single GSM physical channel carrying a varying number of logical channels between the MS and BTS.

Timeslots and TDMA Frames

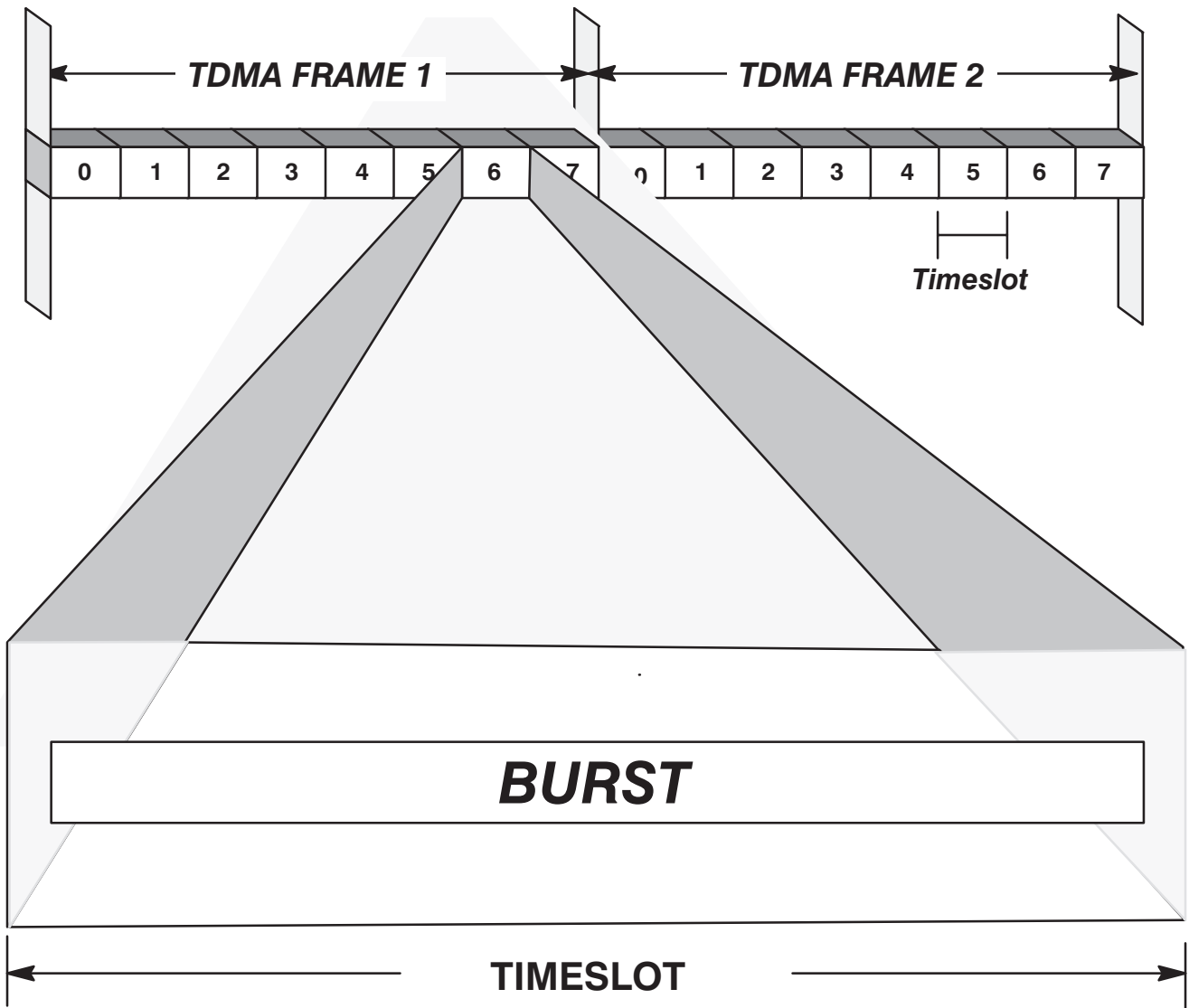

GSM Logical Channels

There are two main groups of logical channels, traffic channels and control channels.

Traffic Channels (TCH)

The traffic channel carries speech or data information. The different types of traffic channel are listed below:

Full rate

- TCH/FS: Speech (13 kbit/s net, 22.8 kbit/s gross)
- TCH/EFR: Speech (12.2 kbit/s net, 22.8 kbit/s gross)
 - TCH/F9.6: 9.6 kbit/s – data
 - TCH/F4.8: 4.8 kbit/s – data
 - TCH/F2.4: 2.4 kbit/s – data

Half rate

- TCH/HS: speech (6.5 kbit/s net, 11.4 kbit/s gross)
 - TCH/H4.8: 4.8 kbit/s – data
 - TCH/H2.4: 2.4 kbit/s – data

Acronyms:

TCH	Traffic Channel
TCH/FS	Full rate speech channel
TCH/EFR	Enhanced full rate speech
TCH/HS	Half rate speech channel
TCH/9.6	Data channel 9.6 kbit/s
TCH/4.8	Data channel 4.8 kbit/s
TCH/2.4	Data channel 2.4 kbit/s

Speech Channels

Speech channels are supported by two different methods of coding known as Full Rate (FR) and Enhanced Full Rate (EFR). Enhanced Full Rate coding provides a speech service that has improved voice quality from the original Full Rate speech coding, whilst using the same air interface bandwidth. EFR employs a new speech coding algorithm and additions to the full rate channel coding algorithm to accomplish this improved speech service, however, it will only be supported by Phase 2+ mobiles onwards.

Channels on the Air Interface

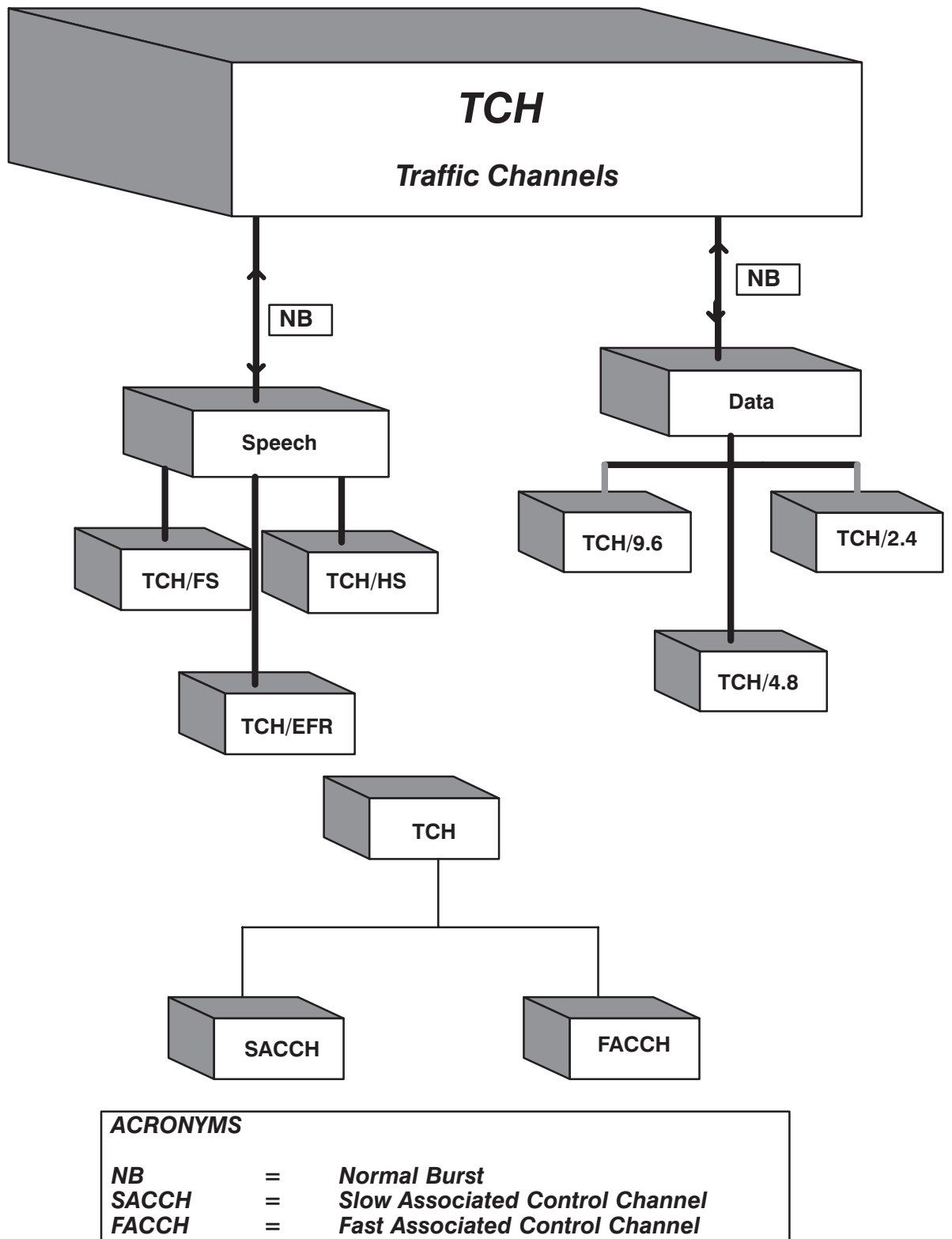

GSM Control Channel Groups

These are: Broadcast Control Channel (BCCH); Common Control Channel (CCCH); Dedicated Control Channel (DCCH).

BCCH Group

The Broadcast Control Channels are downlink only (BSS to MS) and comprise the following:

- BCCH carries information about the network, a MSs present cell and the surrounding cells. It is transmitted continuously as its signal strength is measured by all MSs on surrounding cells.
- The Synchronizing Channel (SCH) carries information for frame synchronization.
- The Frequency Control Channel (FCCH) provides information for carrier synchronization.

CCCH Group

The Common Control Channel Group works in both uplink and downlink directions.

- Random Access Channel (RACH) is used by MSs to gain access to the system.
- Paging Channel (PCH) and Access Granted Channel (AGCH) operate in the "downlink" direction. The AGCH is used to assign resources to the MS, such as a Stand-alone Dedicated Control Channel (SDCCH). The PCH is used by the system to call a MS. The PCH and AGCH are never used at the same time.
- Cell Broadcast Channel (CBCH) is used to transmit messages to be broadcast to all MSs within a cell, for example, road traffic information, sporting results.

DCCH Group

Dedicated Control Channels are assigned to a single MS for call setup and subscriber validation. DCCH comprises:

- Stand-alone Dedicated Control Channel (SDCCH) which supports the transfer of Data to and from the MS during call setup and validation.
- Associated Control Channel. This consists of Slow ACCH which is used for radio link measurement and power control messages. Fast ACCH is used to pass "event" type messages, for example, handover messages. Both FACCH and SACCH operate in uplink and downlink directions.

Acronyms

BCCH	Broadcast Control Channel	CCCH	Common Control Channel
DCCH	Dedicated Control Channel	ACCH	Associated Control Channel
SDCCH	Stand-alone Dedicated Control Channel	RACH	Random Access Channel
		PCH	Paging Channel
AGCH	Access Grant Channel	CBCH	Cell Broadcast Channel

Control Channels

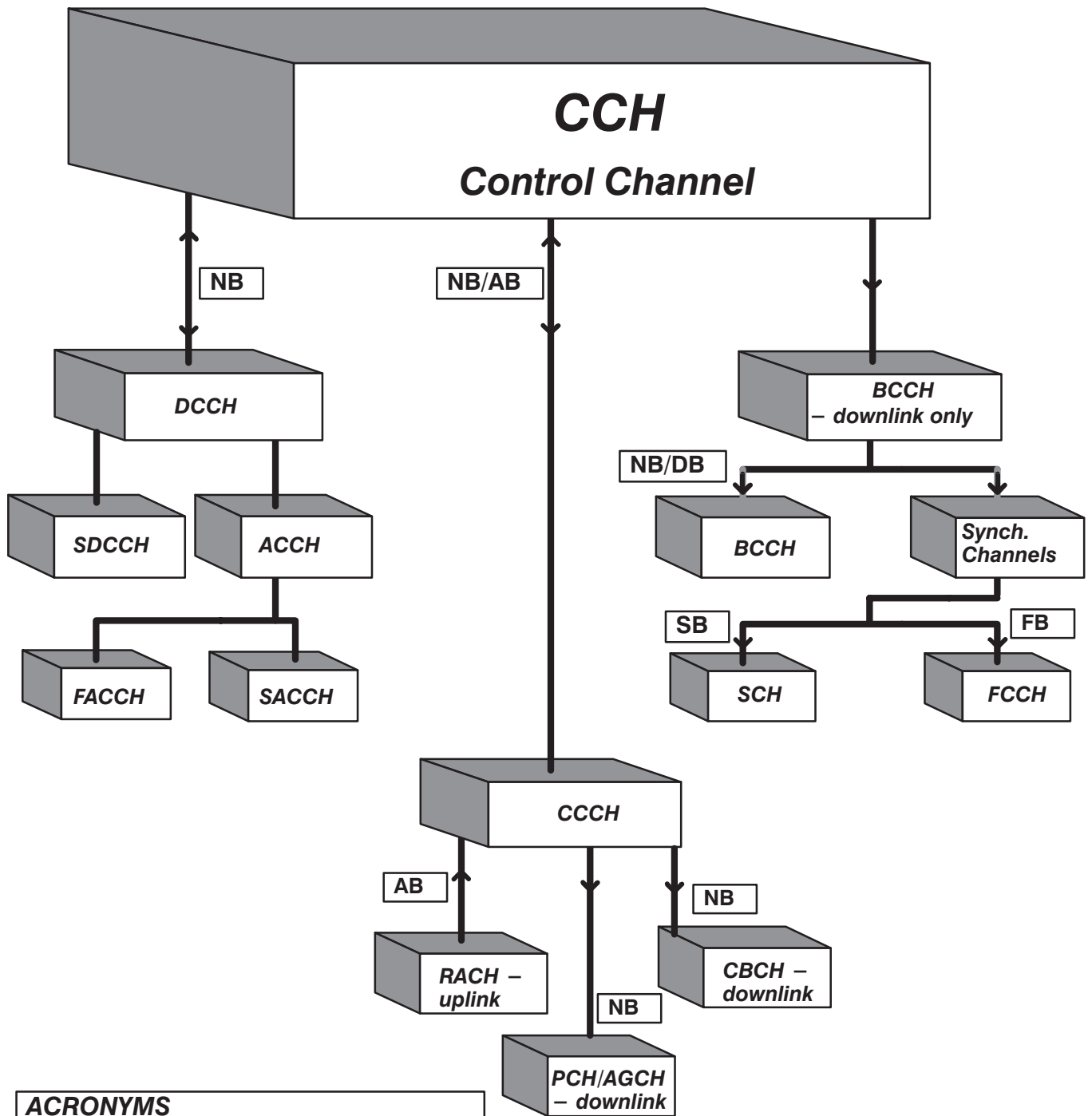

ACRONYMS
NB = NORMAL BURST
FB = FREQUENCY BURST
SB = SYNCHRONISATION BURST
AB = ACCESS BURST
DB = DUMMY BURST

GSM Logical Channels

Control Channels

Broadcast Control Channel (BCCH)

The Broadcast Control Channel is transmitted by the BTS at all times. The RF carrier used to transmit the BCCH is referred to as the BCCH carrier. The information carried on the BCCH is monitored by the MS periodically (at least every 30 secs), when it is switched on and not in a call.

Broadcast Control Channel (BCCH) – Carries the following information (this is only a partial list):

- Location Area Identity (LAI).
- List of neighbouring cells which should be monitored by the MS.
- List of frequencies used in the cell.
- Cell identity.
- Power control indicator.
- DTX permitted.
- Access control (for example, emergency calls, call barring).
- CBCH description.

The BCCH is transmitted at constant power at all times, and its signal strength is measured by all MS which may seek to use it. “Dummy” bursts are transmitted to ensure continuity when there is no BCCH carrier traffic.

- **Frequency Correction Channel (FCCH)**

This is transmitted frequently on the BCCH timeslot and allows the mobile to synchronize its own frequency to that of the transmitting base site. The FCCH may only be sent during timeslot 0 on the BCCH carrier frequency and therefore it acts as a flag to the mobile to identify Timeslot 0.

- **Synchronization Channel (SCH)**

The SCH carries the information to enable the MS to synchronize to the TDMA frame structure and know the timing of the individual timeslots. The following parameters are sent:

- Frame number.
- Base Site Identity Code (BSIC).

The MS will monitor BCCH information from surrounding cells and store the information from the best six cells. The SCH information on these cells is also stored so that the MS may quickly resynchronize when it enters a new cell.

Broadcast Control Channel (BCCH)

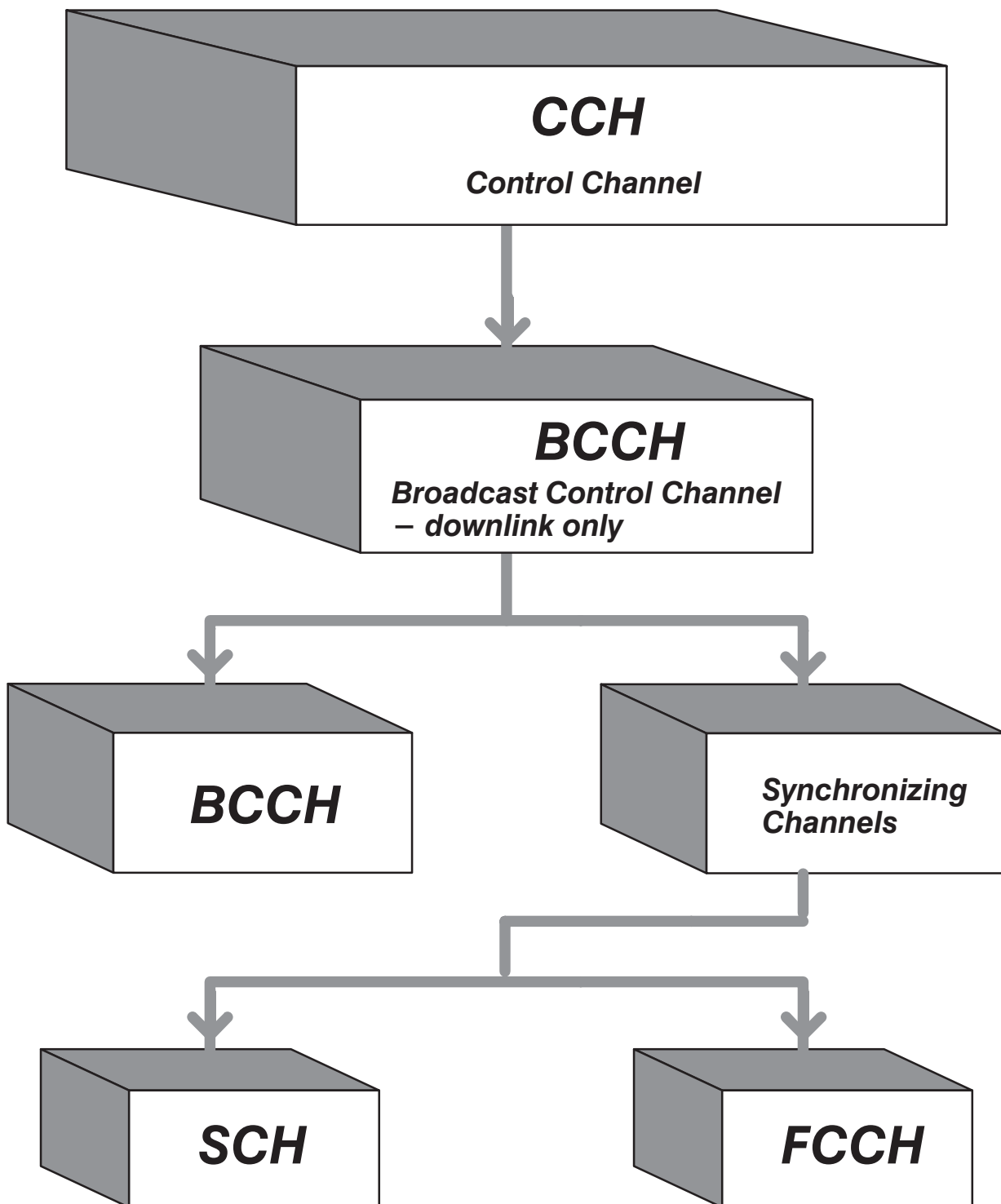

Control Channels

Common Control Channels (CCCH)

The Common Control Channel (CCCH) is responsible for transferring control information between all mobiles and the BTS. This is necessary for the implementation of “call origination” and “call paging” functions.

It consists of the following:

- **Random Access Channel (RACH)**
Used by the mobile when it requires to gain access to the system. This occurs when the mobile initiates a call or responds to a page.
- **Paging Channel (PCH)**
Used by the BTS to page MS, (paging can be performed by an IMSI, TMSI or IMEI).
- **Access Grant Control Channel (AGCH)**
Used by the BTS to assign a dedicated control channel to a MS in response to an access message received on the Random Access Channel. The MS will move to the dedicated channel in order to proceed with either a call setup, response to a paging message, Location Area Update or Short Message Service.
- **Cell Broadcast Channel (CBCH)**
This channel is used to transmit messages to be broadcast to all MSs within a cell. The CBCH uses a dedicated control channel to send its messages, however it is considered a common channel because the messages can be received by all mobiles in the cell.

Active MSs must frequently monitor both BCCH and CCCH. The CCCH will be transmitted on the RF carrier with the BCCH.

Acronyms:

CCCH	Common Control Channel
RACH	Random Access Channel
PCH	Paging Channel
AGCH	Access Grant Channel
CBCH	Cell Broadcast Channel

Common Control Channel (CCCH)

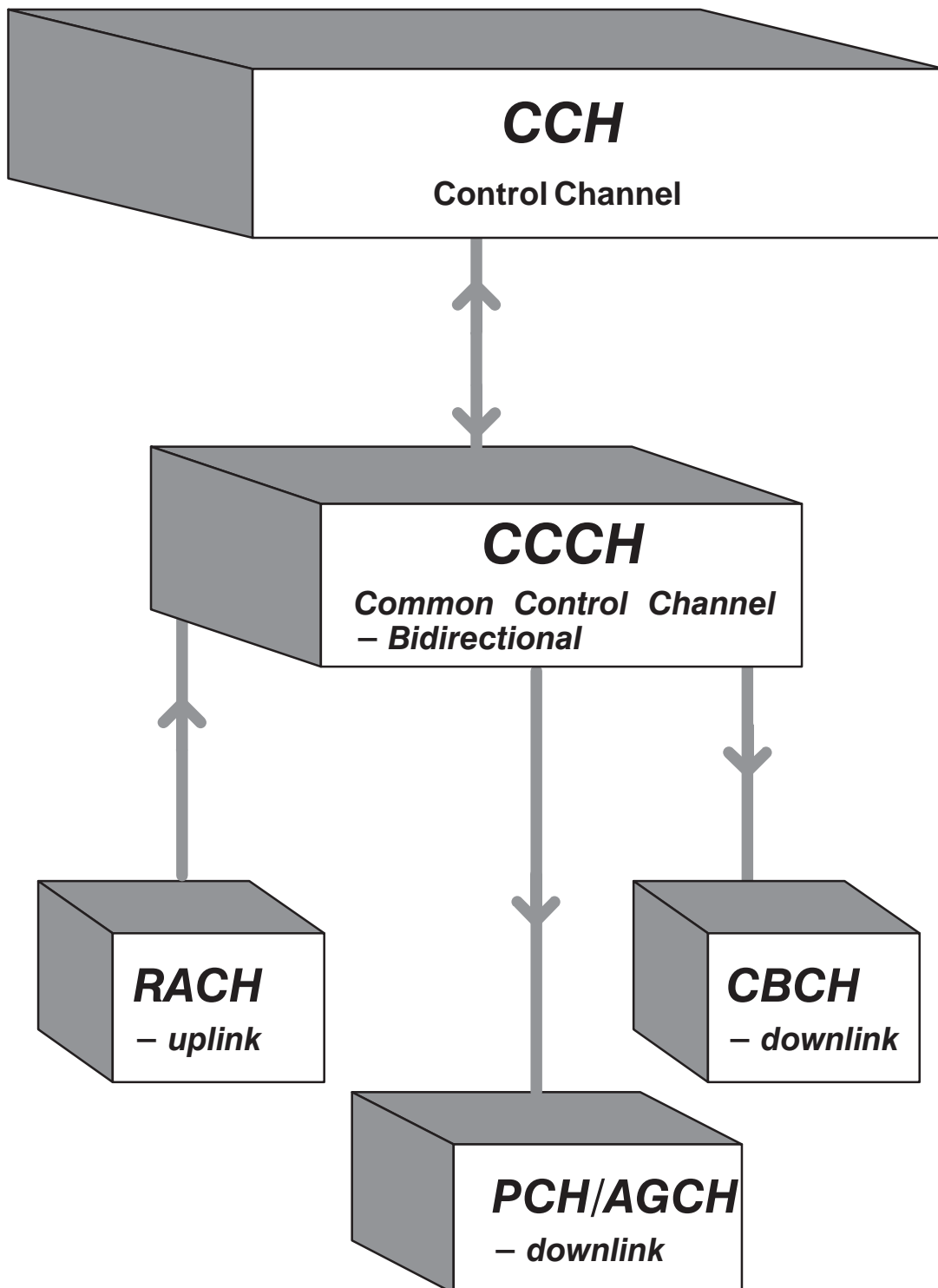

Control Channels

Dedicated Control Channels (DCCH)

The DCCH is a single timeslot on an RF carrier which is used to convey eight Stand-alone Dedicated Control Channels (SDCCH). A SDCCH is used by a single MS for call setup, authentication, location updating and SMS point to point.

As we will see later, SDCCH can also be found on a BCCH/CCCH timeslot, this configuration only allows four SDCCHs.

Associated Control Channels (ACCH)

These channels can be associated with either an SDCCH or a TCH. They are used for carrying information associated with the process being carried out on either the SDCCH or the TCH.

- **Slow Associated Control Channel (SACCH)**

Conveys power control and timing information in the downlink direction (towards the MS) and Receive Signal Strength Indicator (RSSI), and link quality reports in the uplink direction.

- **Fast Associated Control Channel (FACCH)**

The FACCH is transmitted instead of a TCH. The FACCH “steals” the TCH burst and inserts its own information. The FACCH is used to carry out user authentication, handovers and immediate assignment.

All of the control channels are required for system operation, however, in the same way that we allow different users to share the radio channel by using different timeslots to carry the conversation data, the control channels share timeslots on the radio channel at different times. This allows efficient passing of control information without wasting capacity which could be used for call traffic. To do this we must organise the timeslots between those which will be used for traffic and those which will carry control signalling.

Acronyms:

SDCCH	Stand-alone Dedicated Control Channel
SACCH	Slow Associated Control Channel
FACCH	Fast Associated Control Channel

Dedicated Control Channel (DCCH)

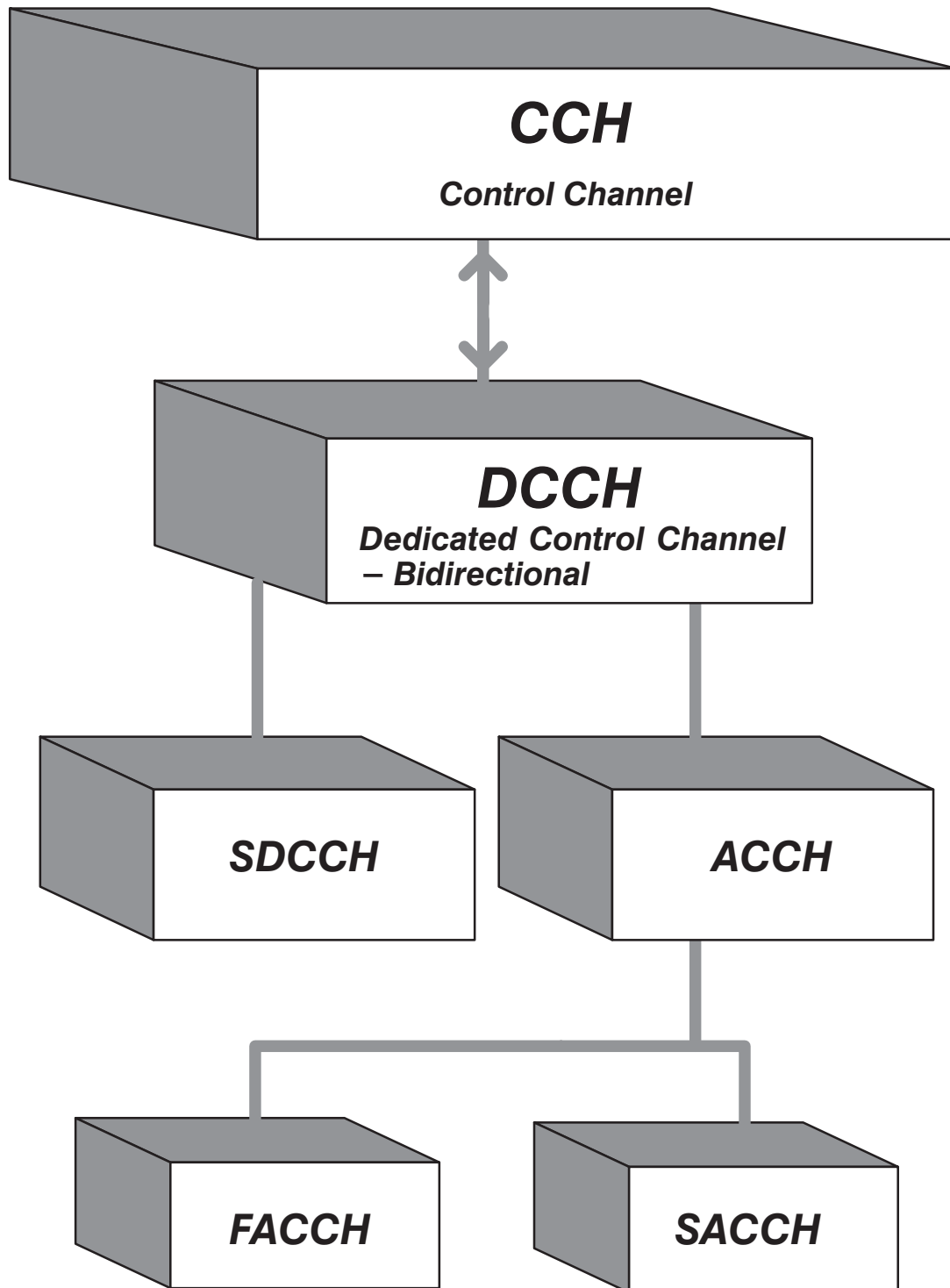

Channel Combinations

The different logical channel types mentioned are grouped into what are called channel combinations. The four most common channel combinations are listed below:

- Full Rate Traffic Channel Combination – TCH8/FACCH + SACCH
- Broadcast Channel Combination – BCCH + CCCH
- Dedicated Channel Combination – SDCCH8 + SACCH8
- Combined Channel Combination – BCCH+CCCH+SDCCH4+SACCH4

The Half Rate Channel Combination (when introduced) will be very similar to the Full Rate Traffic Combination.

- Half Rate Traffic Channel Combination – TCH16/FACCH + SACCH
-

Channel Combinations and Timeslots

The channel combinations we have identified are sent over the air interface in a selected timeslot.

Some channel combinations may be sent on any timeslot, but others must be sent on specific timeslots. Below is a table mapping the channels combinations to their respective timeslots:

Channel Combination	Timeslots
Traffic	Any timeslot
Broadcast	0,2,4,6 (0 must be used first) *
Dedicated	Any timeslot
Combined	0 only

The diagram opposite illustrates how these different channel combinations may be mapped onto the TDMA frame structure.

* If broadcast is assigned to timeslots 2, 4 or 6 then FCCH and SCH will be replaced with dummy bursts since these control channels may only occur on timeslot 0.

Note:

Only one BCCH/CCCH timeslot is required per cell (not RF carrier).

Timeslots and TDMA Frames

LOW CAPACITY CELL

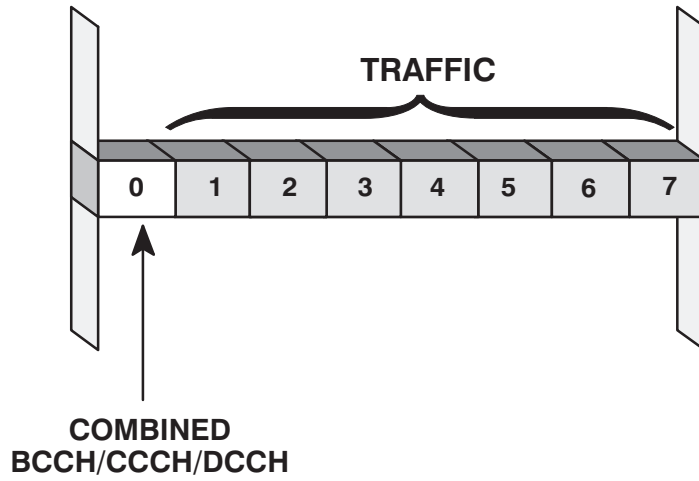

HIGHER CAPACITY CELL

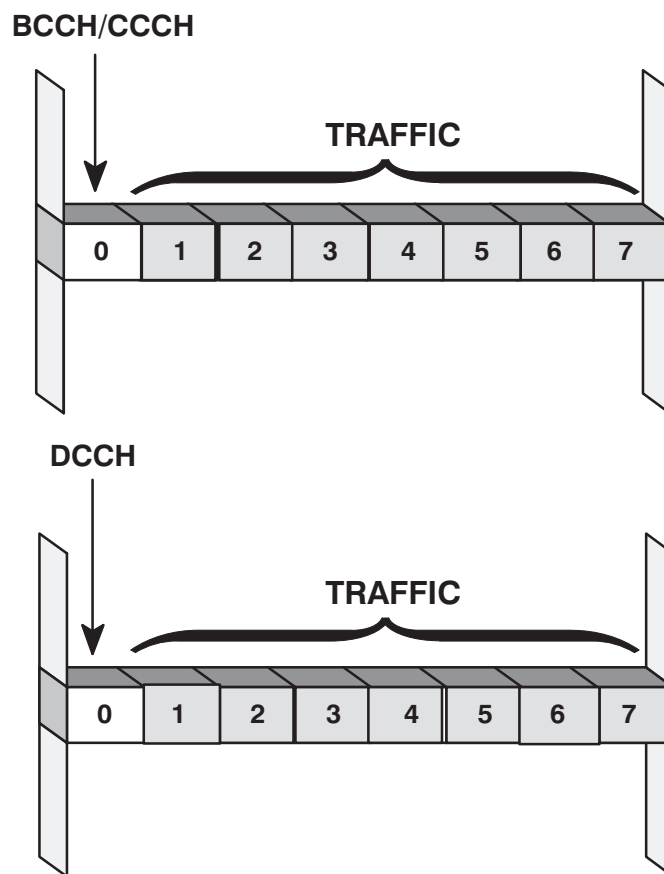

Multiframes and Timing

There are eight timeslots within each TDMA frame, enabling eight physical channels to share a single physical resource – the RF carrier. In turn, each physical channel may be shared by a number of logical channels.

In order to understand how a single physical channel is shared by various logical channels, it is necessary to introduce the GSM *multiframe* structures that make it possible.

The 26-frame Traffic Channel Multiframe

The illustration opposite shows the time relationship between time-slot, TDMA frame, and the 26-frame multiframe. Some of the times shown are approximate numbers as the GSM recommendations actually state the exact values as fractions rather than in decimal form (for example, the exact duration of a time-slot is 15/26 ms).

Note:

The 12th frame (no. 13) in the 26-frame traffic channel multiframe is used by the Slow Associated Control Channel (SACCH) which carries link control information to and from the MS–BTS. Each timeslot in a cell allocated to traffic channel usage will follow this format, that is, 12 bursts of traffic, 1 burst of SACCH, 12 bursts of traffic and 1 idle.

The duration of a 26-frame traffic channel multiframe is 120 ms (26 TDMA frames).

When half rate is used, each frame of the 26-frame traffic channel multiframe allocated for traffic will now carry two MS subscriber calls (the data rate for each MS is halved over the air interface). Although the data rate for traffic is halved, each MS still requires the same amount of SACCH information to be transmitted, therefore frame 12 WILL BE USED as SACCH for one half of the MSs and the others will use it as their IDLE frame, and the same applies for frame 25, this will be used by the MSs for SACCH (those who used frame 12 as IDLE) and the other half will use it as their IDLE frame.

26-Frame Traffic Channel Multiframe

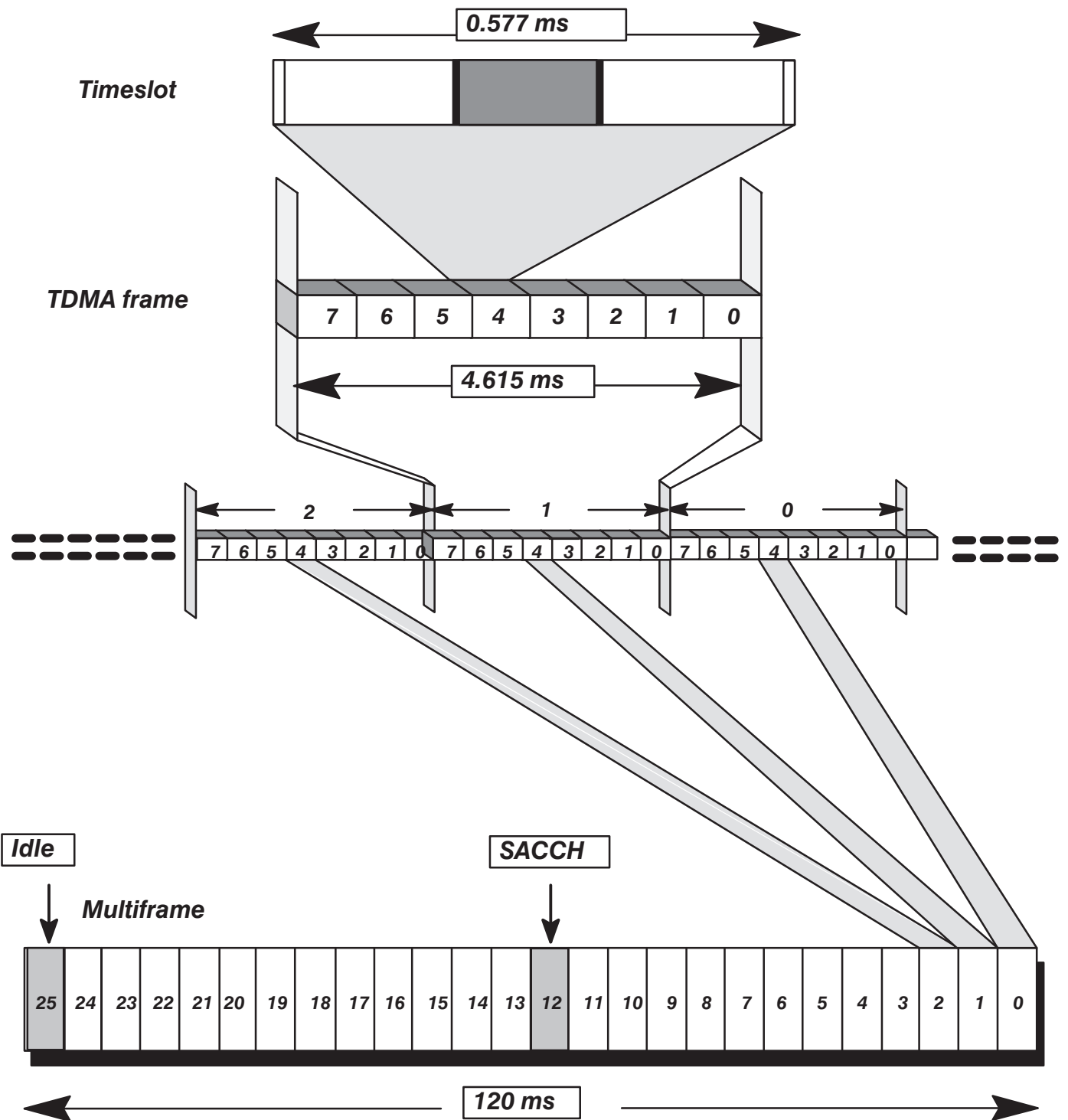

The 51-frame Control Channel Multiframe

The 51-frame structure used for control channels is considerably more complex than the 26-frame structure used for the traffic channels. The 51-frame structure occurs in several forms, depending on the type of control channel and the network provider's requirements.

51-Frame Control Channel Multiframes

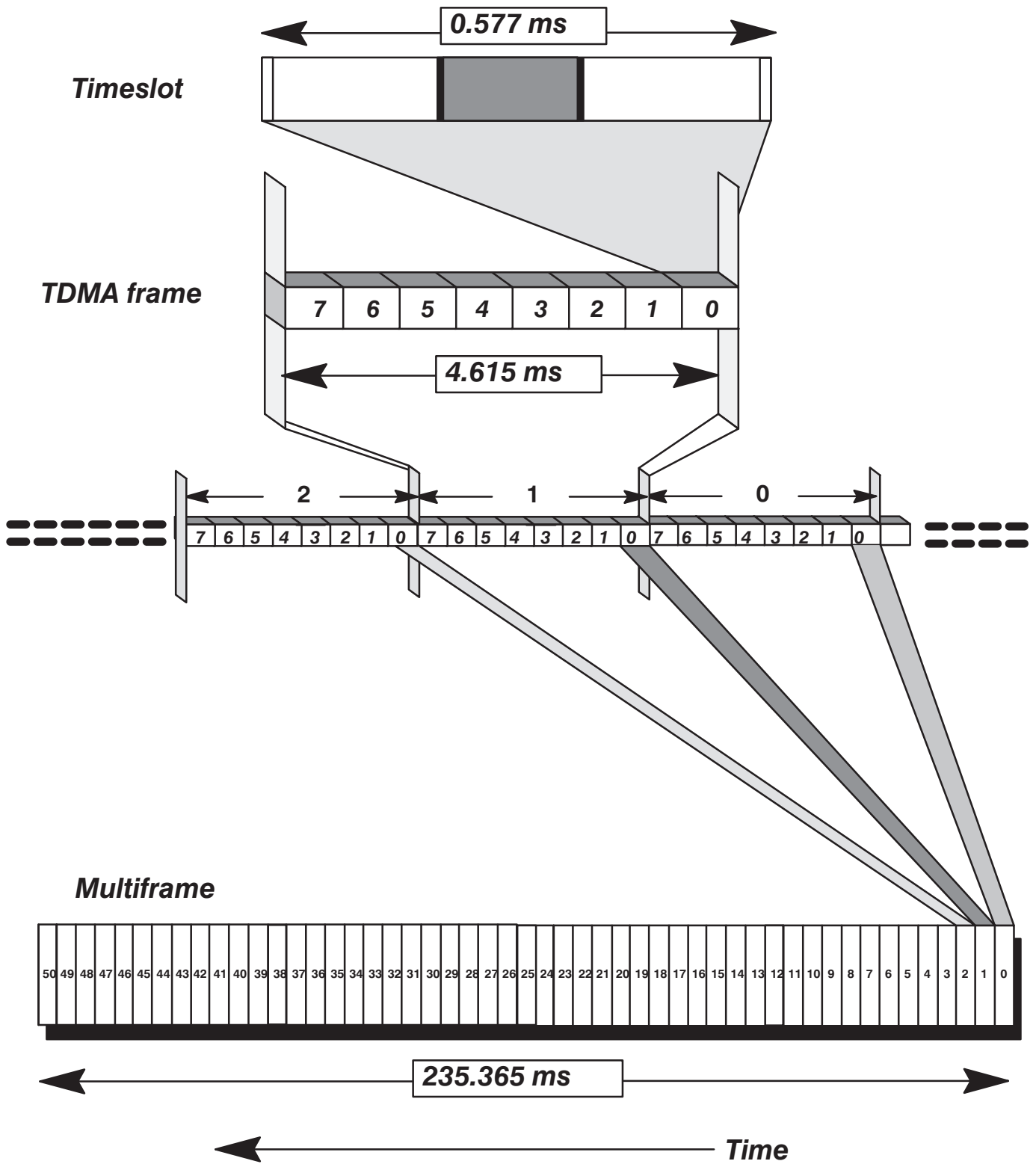

The 51-frame Control Channel Multiframe (BCCH/CCCH)

The BCCH/CCCH 51-frame structure illustrated on the opposite page will apply to timeslot 0 of each TDMA frame on the 'BCCH carrier' (the RF carrier frequency to which BCCH is assigned on a per cell basis). In the diagram, each vertical step represents one repetition of the timeslot (= one TDMA frame), with the first repetition (numbered 0) at the bottom.

Looking at the uplink (MS–BSS) direction, all timeslot 0s are allocated to RACH. This is fairly obvious because RACH is the only control channel in the BCCH/CCCH group which works in the uplink direction. In the downlink direction (BSS–MS), the arrangement is more interesting. Starting at frame 0 of the 51-frame structure, the first timeslot 0 is occupied by a frequency burst ('F' in the diagram), the second by a synchronizing burst ('S') and then the following four repetitions of timeslot 0 by BCCH data (B) in frames 2–5. The following four repetitions of timeslot 0 in frames 6–9 are allocated to CCCH traffic (C), that is, to either PCH (mobile paging channel) or AGCH (access grant channel). Then follows, in timeslot 0 of frames 10 and 11, a repeat of the frequency and synchronising bursts (F and S), four further CCCH bursts (C) and so on. Note that the last timeslot 0 in the sequence (the fifty-first frame – frame 50) is idle.

BCCH/CCCH Multiframe

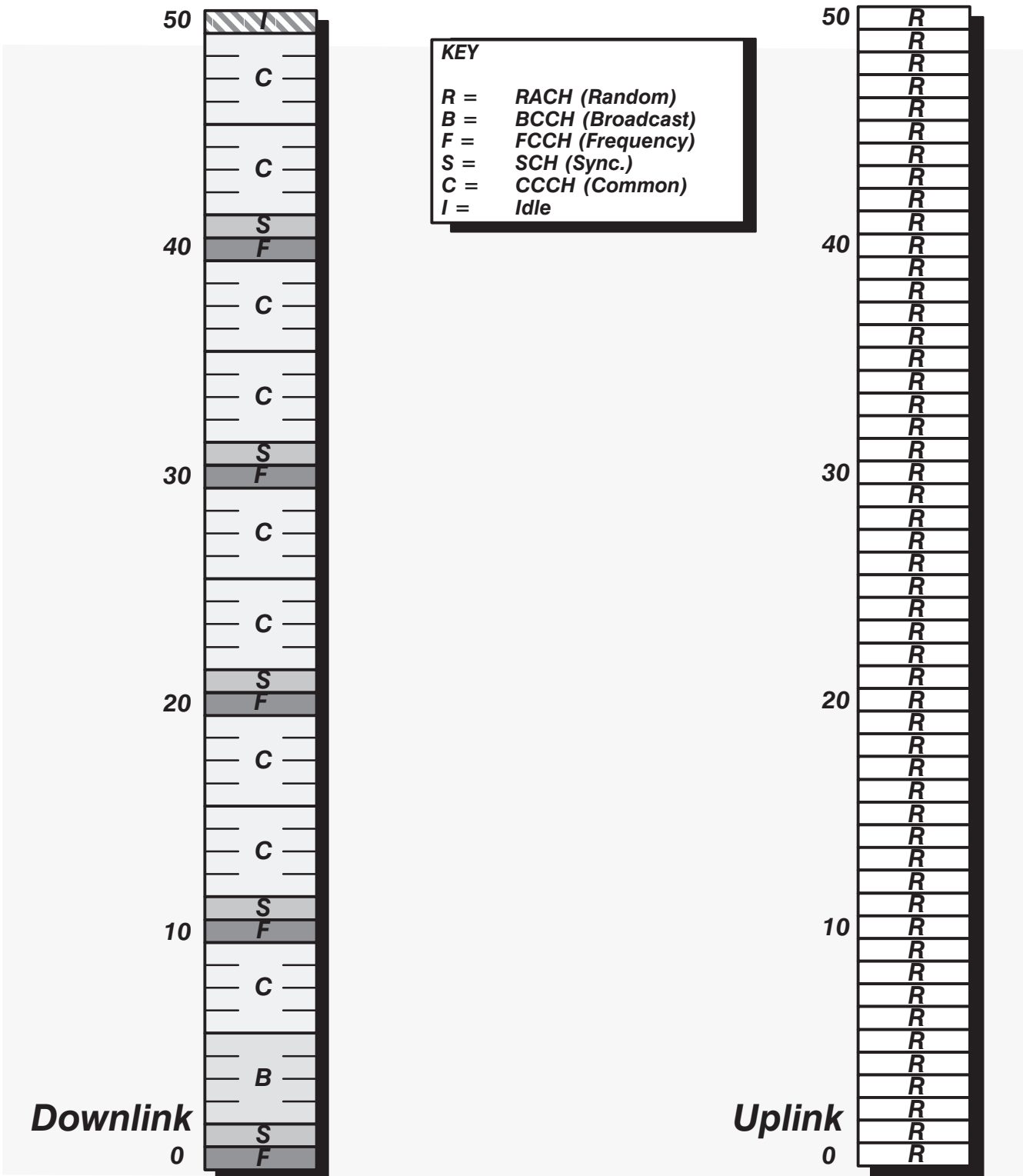

The 51-frame Control Channel Multiframe – DCCH/8 (SDCCH and SACCH)

The diagram opposite shows the 51-frame structure used to accommodate eight SDCCHs, although, as it takes two repetitions of the multiframe to complete the entire sequence, it may be more logical to think of it as a 102-frame structure. This structure may be transmitted on any timeslot.

Note that the SACCHs (shaded) are associated with the SDCCHs. It is important to remember that each SDCCH has an SACCH just like a traffic channel.

i.e. D0 associated with A0

 D1 associated with A1

 . .

 . .

 . .

 . .

 . .

 D7 associated with A7

Note: The downlink and uplink channels are staggered in order to give the mobile time to process the received message and formulate a response.

DCCH/8 Multiframe

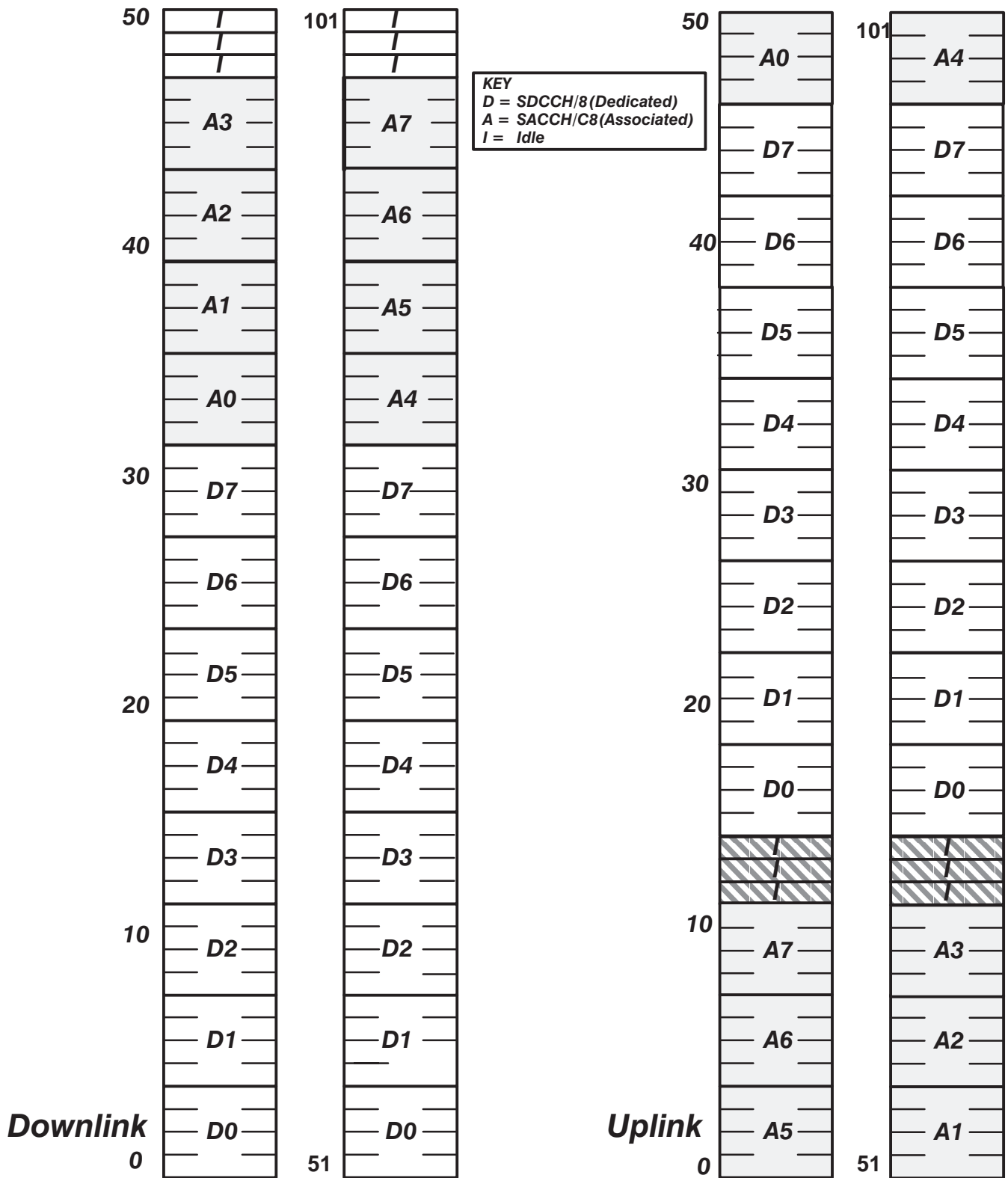

The 51-frame Control Channel Multiframe – Combined Structure

As we can see in the diagram opposite, each of the control channel types are present on a single timeslot. The number of MSs which can effectively use this cell is therefore reduced, as we now only have 3 CCCH groups and 4 SDCCHs, which translates into fewer pages and simultaneous cell setups.

A typical use of this type of control channel timeslot is in rural areas, where the subscriber density is low.

Combined Multiframe

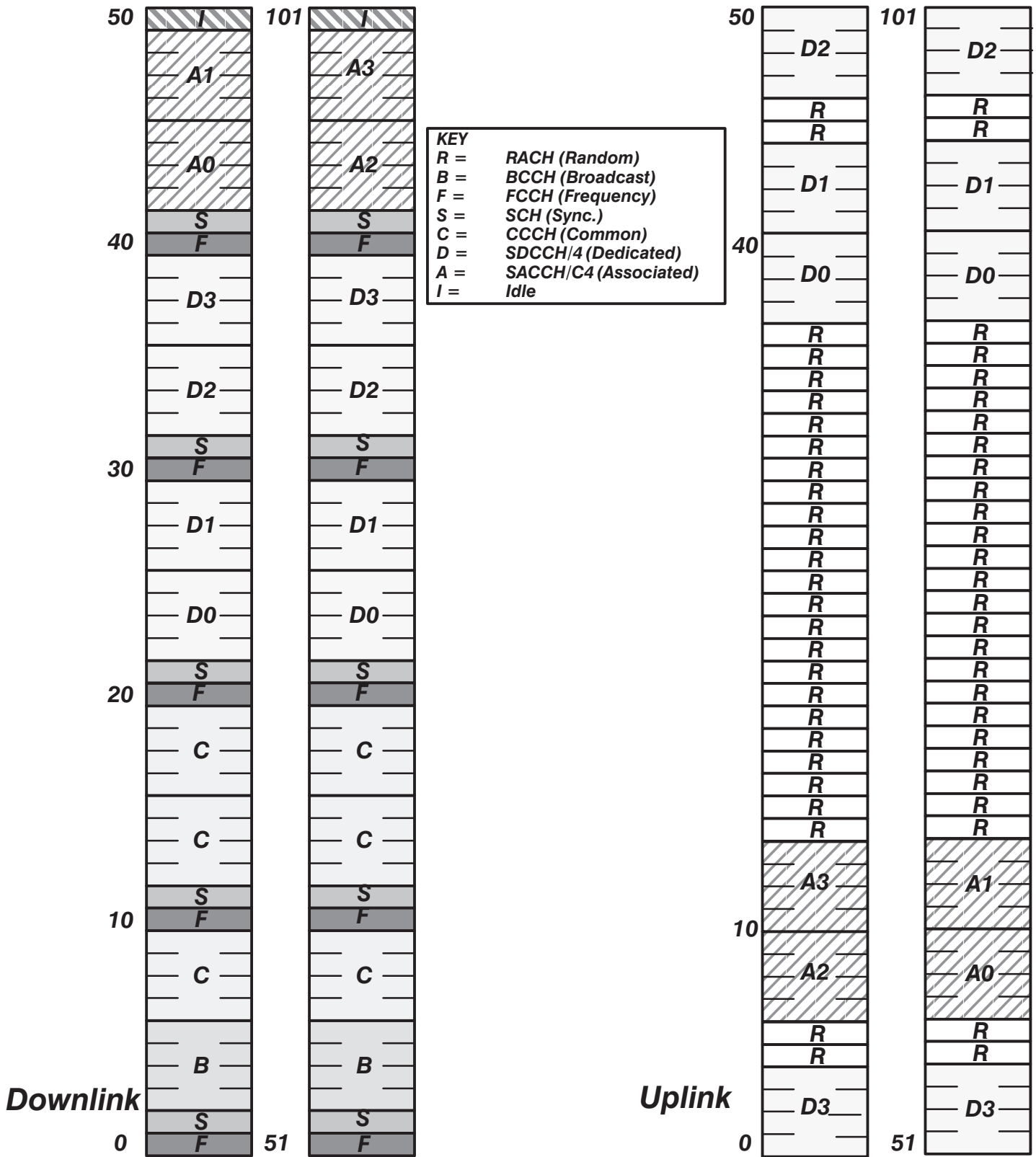

Superframes and Hyperframes

It is not by accident that the control channel multiframe is not a direct multiple of the traffic channel multiframe. From the diagram, it can be seen that any given frame number will only occur simultaneously in both multiframes every 1326 TDMA frames (26 x 51). This number of TDMA frames is termed a “superframe” and it takes 6.12 s to transmit. This arrangement means that the timing of the traffic channel multiframe is always moving in relation to that of the control channel multiframe and this enables a MS to receive and decode BCCH information from surrounding cells.

If the two multiframes were exact multiples of each other, then control channel timeslots would be permanently ‘masked’ by traffic channel timeslot activity. This changing relationship between the two multiframes is particularly important, for example, to a MS which needs to be able to monitor and report the RSSIs of neighbour cells (it needs to be able to ‘see’ all the BCCHs of those cells in order to do this).

The “hyperframe” consists of 2048 superframes, this is used in connection with ciphering and frequency hopping. The hyperframe lasts for over three hours, after this time the ciphering and frequency hopping algorithms are restarted.

Superframe and Hyperframe

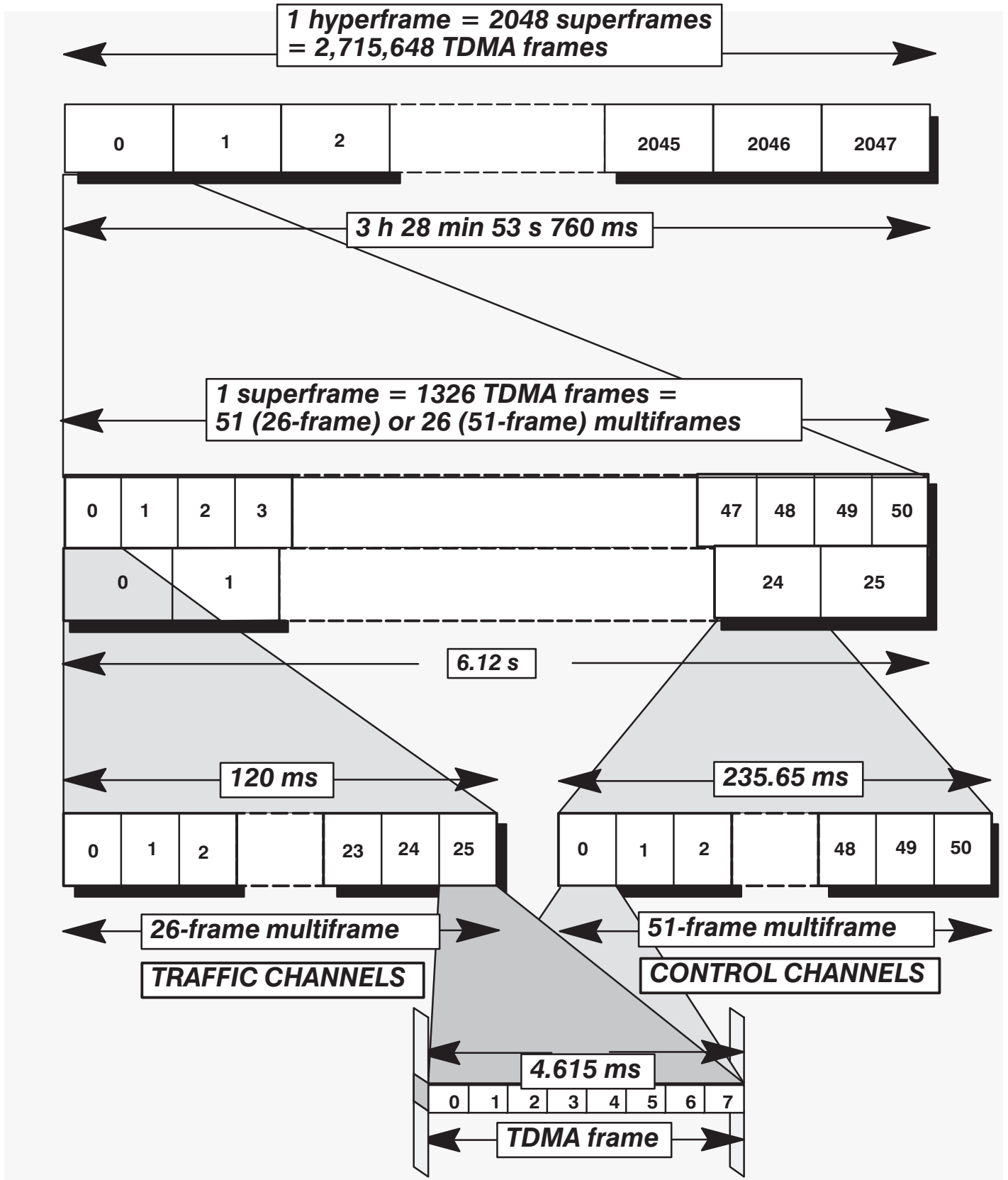

Mobile Activity – Transmit and Receive Timeslots

Overview

As the MS only transmits or receives its own physical channel (normally containing TCH and SACCH) for one-eighth of the time, it uses the remaining time to monitor the BCCHs of adjacent 'target' cells. It completes the process every 480 ms, or four 26-TCH multiframes. The message that it sends to the BSS (on SACCH, uplink) contains the Receive Signal Strength Indication (RSSI) of the adjacent cells, plus that of the link to the BSS itself, plus an indication of the *quality* of the current connection. This quality measurement is somewhat similar to a bit error rate test. Just as the mobile completes one series of measurements, it completes sending the previous series to the BSS and starts to send the latest series; thus the processes of compilation and transmission form a continuous cycle.

Mobile Activity

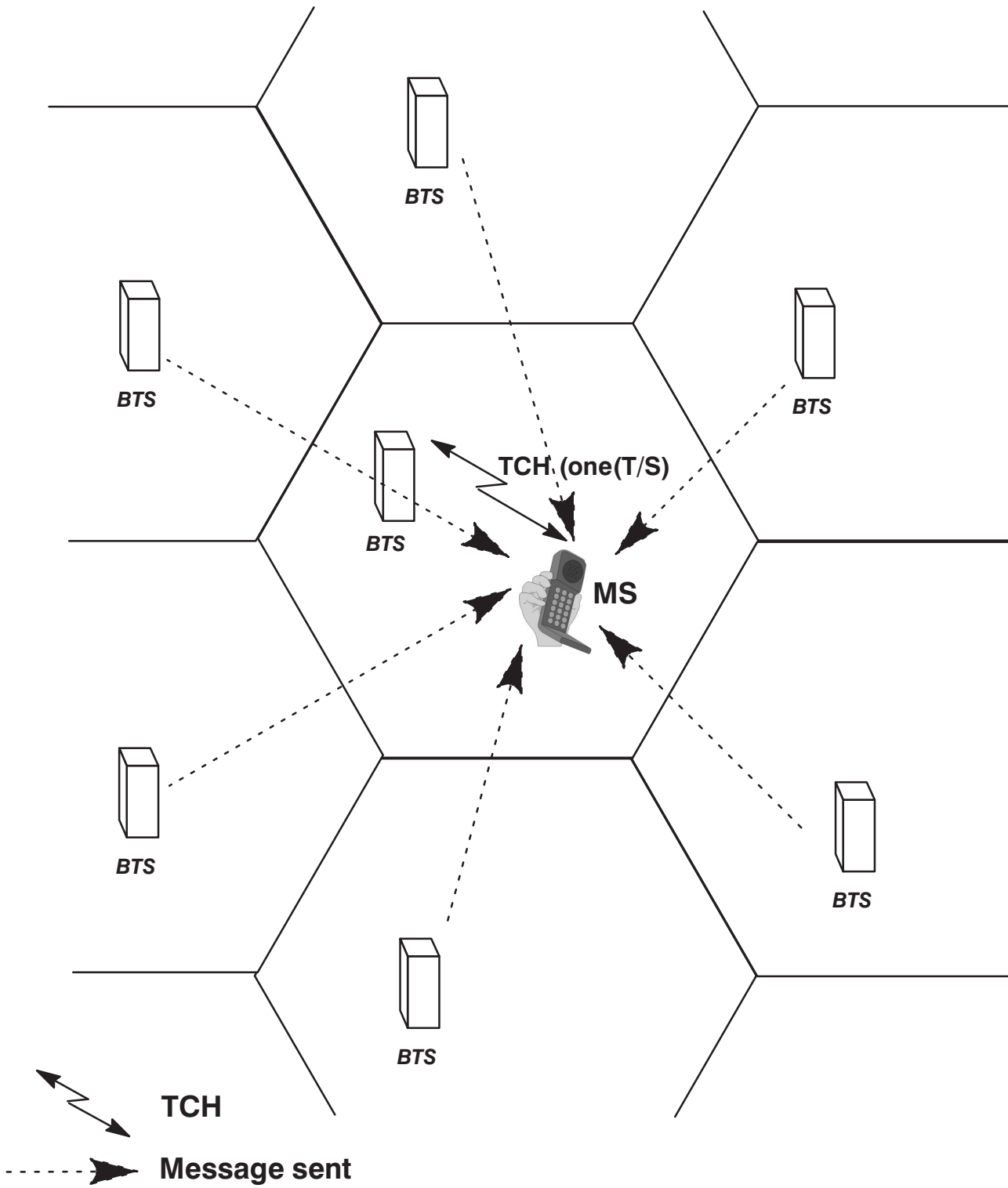

GSM Basic Call Sequence

The diagram opposite reminds us of the basic components and processes involved in setting up a call between a GSM MS and an ordinary “land” telephone.

- **In the MS to Land direction**

The BTS receives a data message from the MS which it passes it to the BSC. The BSC relays the message to the MSC via C7 signalling links, and the MSC then sets up the call to the land subscriber via the PSTN. The MSC connects the PSTN to the GSM network, and allocates a terrestrial circuit to the BSS serving the MS’s location. The BSC of that BSS sets up the air interface channel to the MS and then connects that channel to the allocated terrestrial circuit, completing the connection between the two subscribers.

- **In the Land to MS direction**

The MSC receives its initial data message from the PSTN (via C7) and then establishes the location of the MS by referencing the HLR. It then knows which other MSC to contact to establish the call and that MSC then sets up the call via the BSS serving the MS’s location.

The actual processes are, of course, considerably more complex than described above. Also, there are many different GSM call sequence and handover scenarios – enough to form the subject of their own training programme! In this course we consider in detail just the MS to Land and Land to MS call sequences and the intra-MSC (inter-BSS) handover sequence. This will give you a good appreciation of the messaging that occurs in the GSM system, and how the PLMN interacts with the PSTN.

GSM Basic Call Sequence

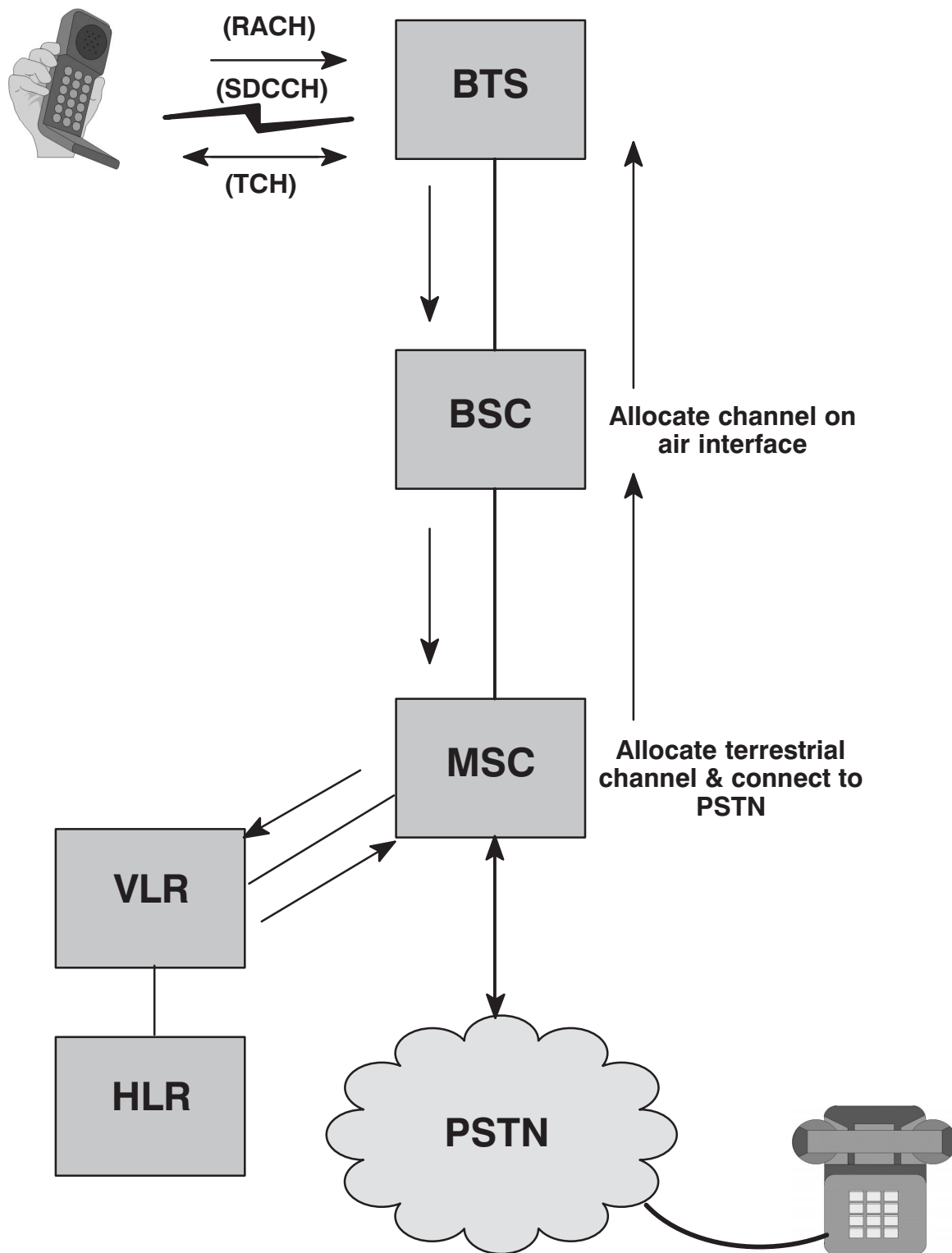

Chapter 6

Channels on the Air Interface

Chapter 6	
Channel Coding on the Air Interface	i
Channel Coding on the Air Interface	6-1
Section Objectives	6-1
GSM Bursts	6-2
Burst Types	6-4
Error Protection and Detection	6-6
Speech Channel Encoding	6-8
Channel Coding for Enhanced Full Rate	6-10
Overview	6-10
Preliminary Channel Coding for EFR	6-10
Error Protection and Detection	6-12
Control Channel Encoding	6-12
Data Channel Encoding	6-14
Mapping Logical Channels onto the TDMA Frame Structure	6-16
Interleaving	6-16
Diagonal Interleaving – Speech	6-18
Transmission – Speech	6-20
Rectangular Interleaving – Control	6-22
Transmission – Control	6-22
Diagonal Interleaving – Data	6-24
Transmission – Data	6-24

Channel Coding on the Air Interface

Section Objectives

On completion of this section the student will be able to:

- Draw the structure of a GSM burst and identify the purpose of each component.
- Have an understanding of the different mechanisms used to protect the air interface from errors on speech, data and control channels.

GSM Bursts

The diagram opposite illustrates a GSM burst. It consists of several different elements. These elements are described below:

- **Info**

This is the area in which the speech, data or control information is held.
- **Guard Period**

The BTS and MS can only receive the burst and decode it, if it is received within the timeslot designated for it. The timing, therefore, must be extremely accurate, but the structure does allow for a small margin of error by incorporating a 'guard period' as shown in the diagram. To be precise, the timeslot is 0.577 ms long, whereas the burst is only 0.546 ms long, therefore there is a time difference of 0.031 ms to enable the burst to hit the timeslot.
- **Stealing Flags**

These two bits are set when a traffic channel burst has been "stolen" by a FACCH (the Fast Associated Control Channel). One bit set indicates that half of the block has been stolen.
- **Training Sequence**

This is used by the receiver's equalizer as it estimates the transfer characteristic of the physical path between the BTS and the MS. The training sequence is 26 bits long.
- **Tail Bits**

These are used to indicate the beginning and end of the burst.

GSM Burst and TDMA Frame

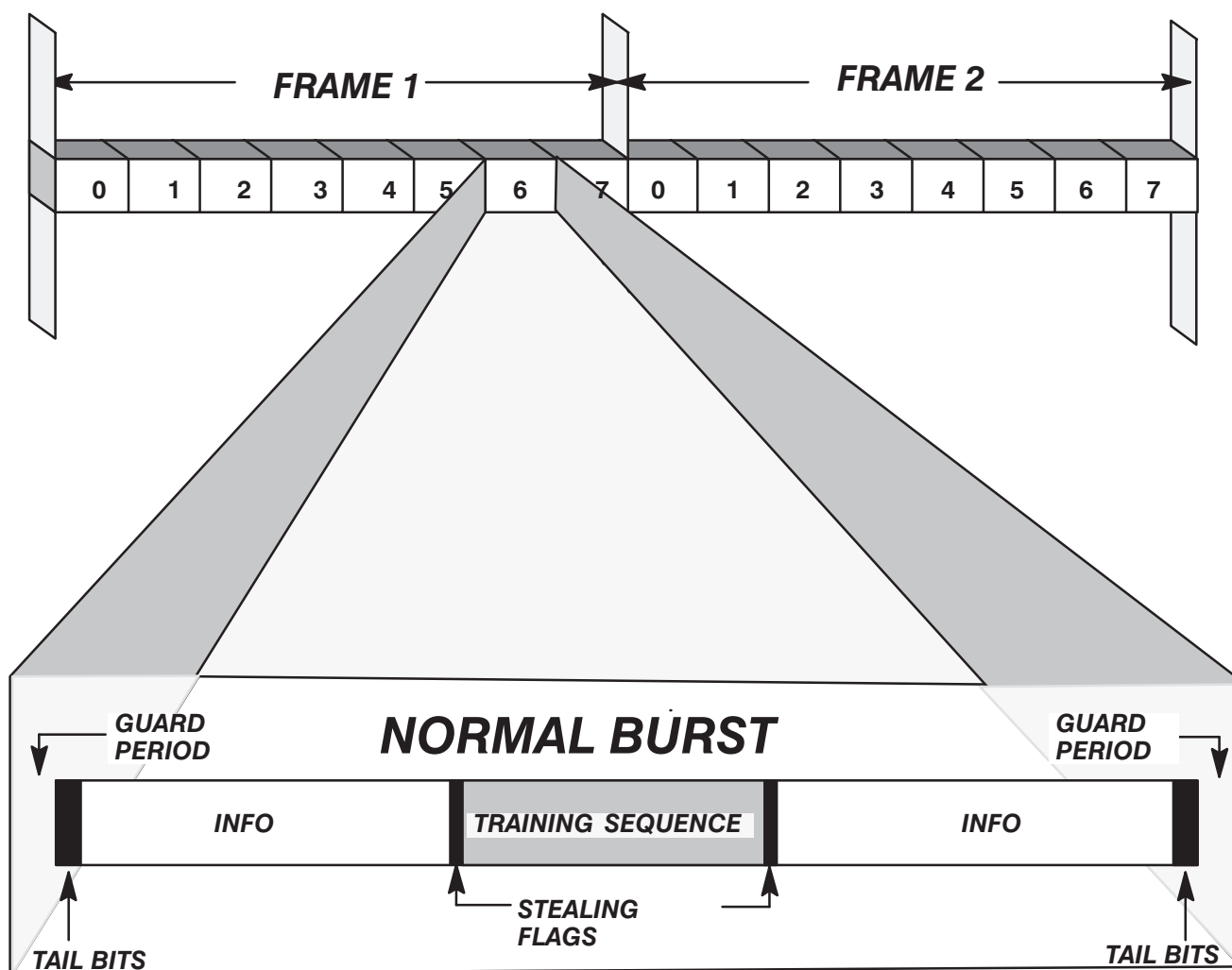

Burst Types

The diagram opposite shows the five types of burst employed in the GSM air interface. All bursts, of whatever type, have to be timed so that they are received within the appropriate timeslot of the TDMA frame.

The burst is the sequence of bits transmitted by the BTS or MS, the timeslot is the discrete period of real time within which it must arrive in order to be correctly decoded by the receiver:

- **Normal Burst**

The normal burst carries traffic channels and all types of control channels apart from those mentioned specifically below. (Bi-directional).

- **Frequency Correction Burst**

This burst carries FCCH downlink to correct the frequency of the MS's local oscillator, effectively locking it to that of the BTS.

- **Synchronization Burst**

So called because its function is to carry SCH downlink, synchronizing the timing of the MS to that of the BTS.

- **Dummy Burst**

Used when there is no information to be carried on the unused timeslots of the BCCH Carrier (downlink only).

- **Access Burst**

This burst is of much shorter duration than the other types. The increased guard period is necessary because the timing of its transmission is unknown. When this burst is transmitted, the BTS does not know the location of the MS and therefore the timing of the message from the MS can not be accurately accounted for. (The Access Burst is uplink only.)

GSM Burst Types

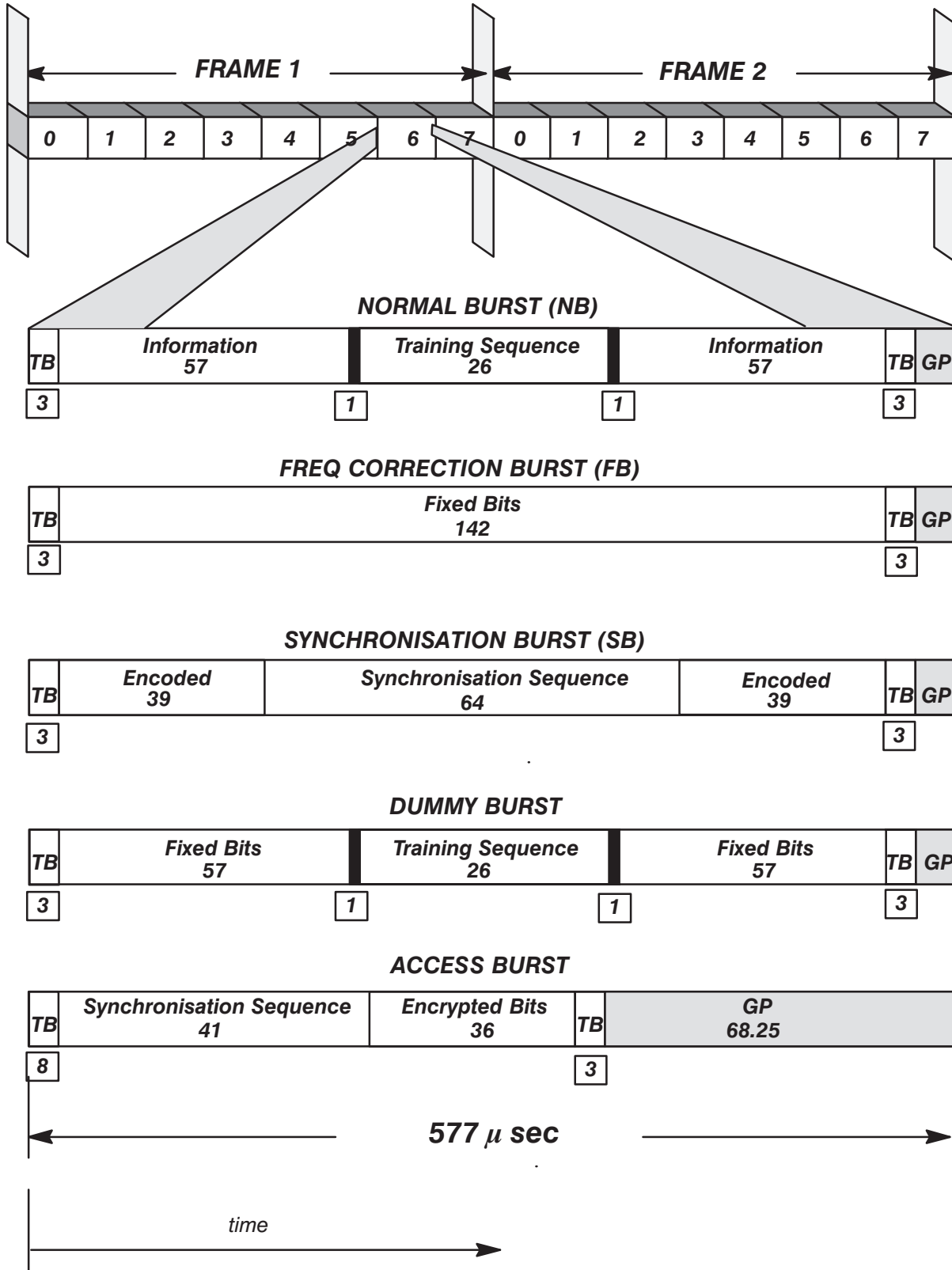

Error Protection and Detection

To protect the logical channels from transmission errors introduced by the radio path, many different coding schemes are used. The diagram overleaf illustrates the coding process for speech, control and data channels; the sequence is very complex.

The coding and interleaving schemes depend on the type of logical channel to be encoded. All logical channels require some form of convolutional encoding, but since protection needs are different, the code rates may also differ.

Three coding protection schemes:

- **Speech Channel Encoding**

The speech information for one 20 ms speech block is divided over eight GSM bursts. This ensures that if bursts are lost due to interference over the air interface the speech can still be accurately reproduced.

- **Common Control Channel Encoding**

20 ms of information over the air will carry four bursts of control information, for example BCCH. This enables the bursts to be inserted into one TDMA multiframe.

- **Data Channel Encoding**

The data information is spread over 22 bursts. This is because every bit of data information is very important. Therefore, when the data is reconstructed at the receiver, if a burst is lost, only a very small proportion of the 20 ms block of data will be lost. The error encoding mechanisms should then enable the missing data to be reconstructed.

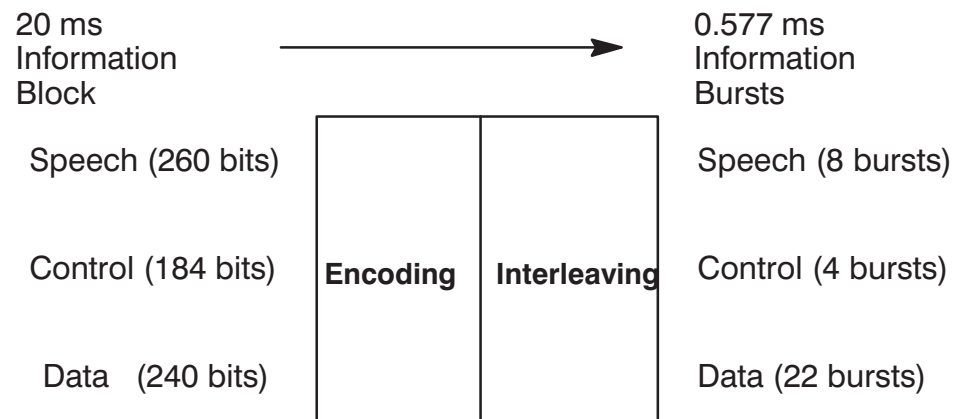

Error Protection and Detection

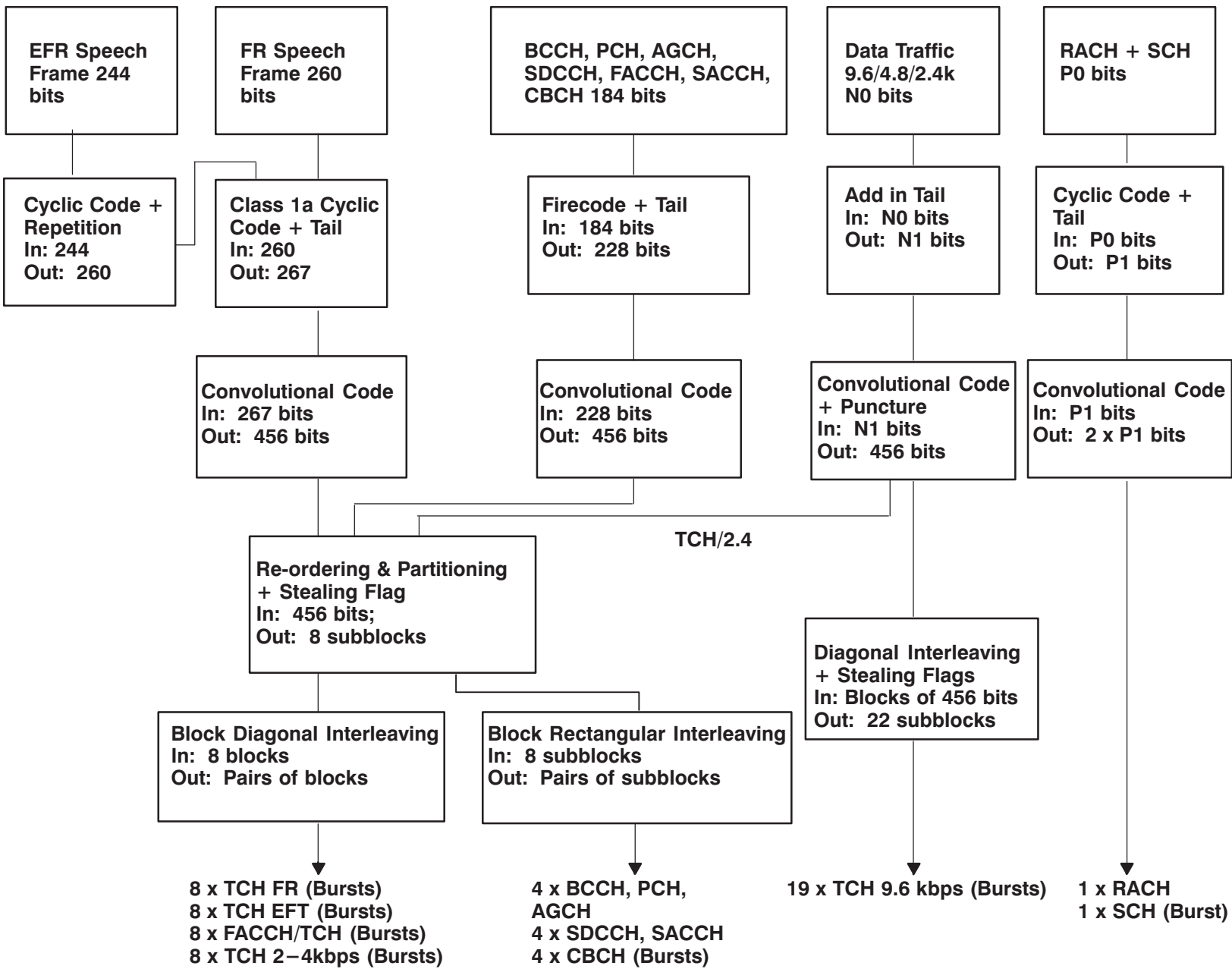

Speech Channel Encoding

The BTS receives transcoded speech over the A-bis interface from the BSC. At this point the speech is organized into its individual logical channels by the BTS. These logical channels of information are then channel coded before being transmitted over the air interface.

The transcoded speech information is received in frames, each containing 260 bits. The speech bits are grouped into three classes of sensitivity to errors, depending on their importance to the intelligibility of speech.

- **Class 1a**

Three parity bits are derived from the 50 class 1a bits. Transmission errors within these bits are catastrophic to speech intelligibility, therefore, the speech decoder is able to detect uncorrectable errors within the class 1a bits. If there are class 1a bit errors, the whole block is usually ignored.

- **Class 1b**

The 132 class 1b bits are not parity checked, but are fed together with the class 1a and parity bits to a convolutional encoder. Four tail bits are added which set the registers in the receiver to a known state for decoding purposes.

- **Class 2**

The 78 least sensitive bits are not protected at all.

The resulting 456 bit block is then interleaved before being sent over the air interface.

Note:

Over the A-bis link, when using Full Rate Speech vocoding, 260 bits are transmitted in 20 ms equalling a transmission rate of 13 kbit/s. If Enhanced Full Rate is used then 244 bits are transmitted over the A-bis link for each 20 ms sample. The EFR Frame is treated to some preliminary coding to build it up to 260 bits before being applied to the same channel coding as Full Rate.

The encoded speech now occupies 456 bits but is still transmitted in 20 ms thus raising the transmission rate to 22.8 kbit/s.

Speech Channel Coding

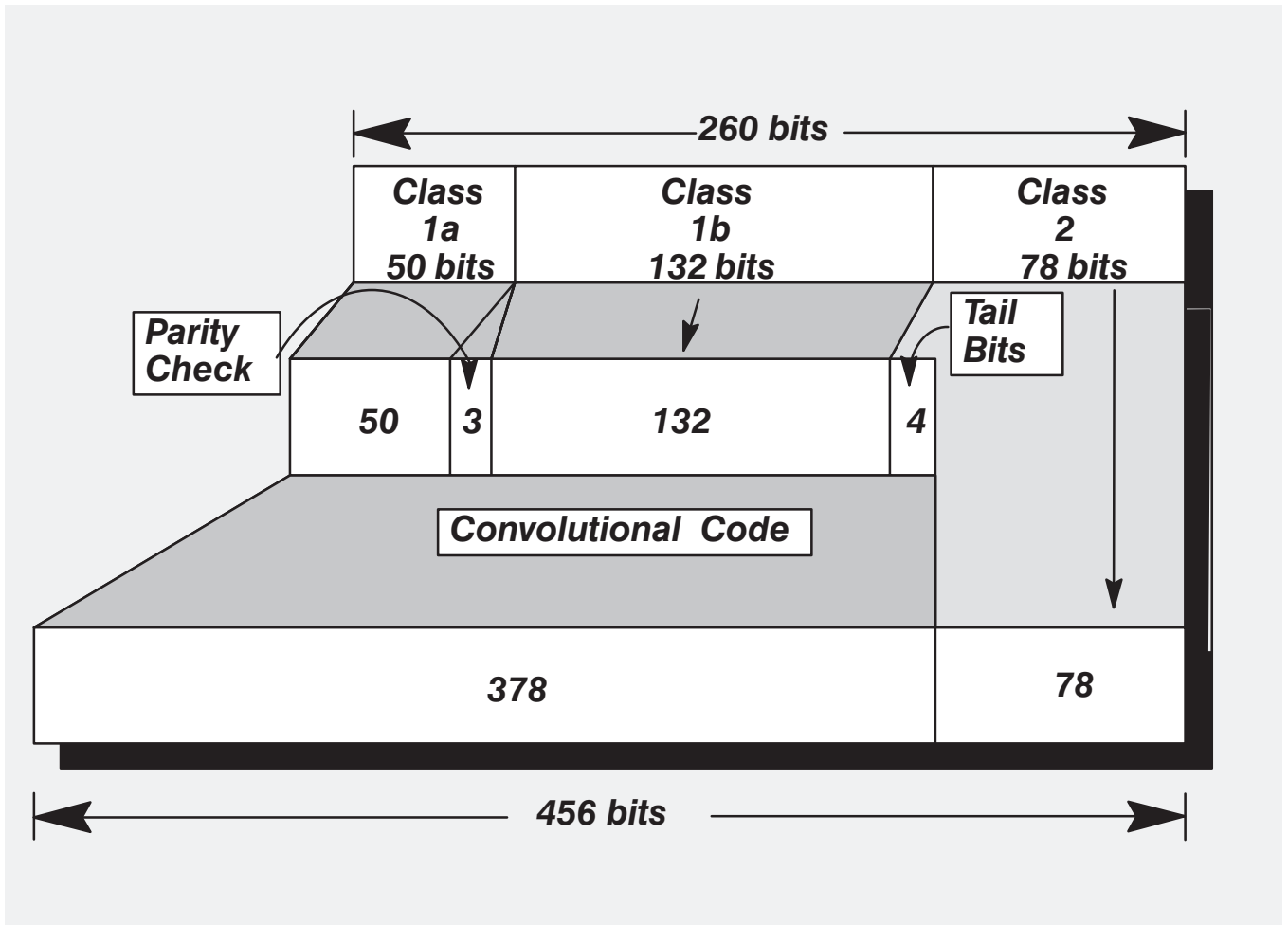

Channel Coding for Enhanced Full Rate

Overview

The transcoding for Enhanced Full Rate produces 20 ms speech frames of 244 bits for channel coding on the air interface. After passing through a preliminary stage which adds 16 bits to make the frame up to 260 bits the EFR speech frame is treated to the same channel coding as Full Rate.

The additional 16 bits correspond to an 8 bit CRC which is generated from the 50 class 1a bits plus the 15 most important class 1b bits and 8 repetition bits corresponding to 4 selected bits in the original EFR frame of 244 bits.

Preliminary Channel Coding for EFR

EFR Speech Frame

50 Class 1a + 124 Class 1b + 70 Class 2 = 244 bits

Preliminary Coding

8 bit CRC generated from 50 Class 1a + 15 Class 1b added to Class 1b bits

8 repetition bits added to Class 2 bits

Output from Preliminary Coding

50 Class 1a + 132 Class 1b + 78 Class 2 = 260 bits

EFR frame of 260 bits passed on for similar channel coding as Full Rate.

Preliminary Coding for Enhanced Full Rate Speech

244 bits

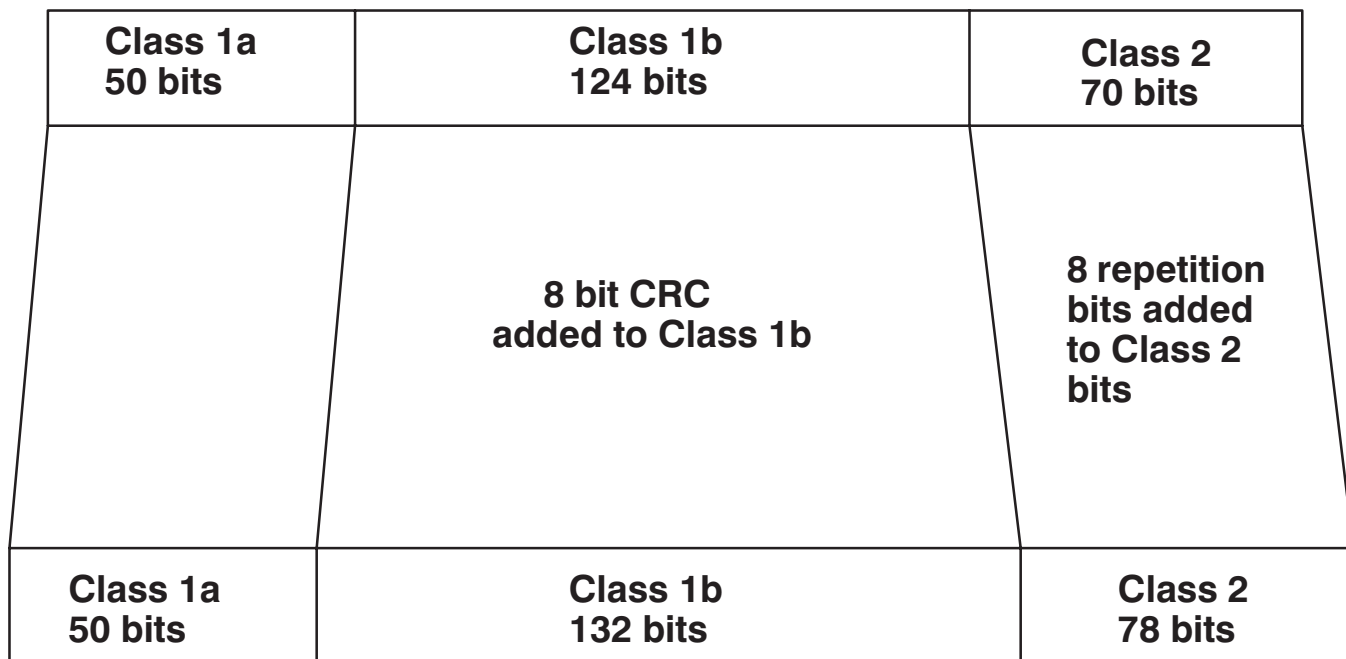

260 bits

Error Protection and Detection

Control Channel Encoding

The diagram opposite shows the principle of the error protection for the control channels. This scheme is used for all the logical signalling channels, the synchronization channel (SCH) and the random access burst (RACH). The diagram applies to SCH and RACH, but with different numbers.

When control information is received by the BTS it is received as a block of 184 bits. These bits are first protected with a cyclic block code of a class known as a Fire Code,. This is particularly suitable for the detection and correction of burst errors, as it uses 40 parity bits. Before the convolutional encoding, four tail bits are added which set the registers in the receiver to a known state for decoding purposes.

The output from the encoding process for each block of 184 bits of signalling data is 456 bits, exactly the same as for speech. The resulting 456 bit block is then interleaved before being sent over the air interface.

Control Channel Encoding

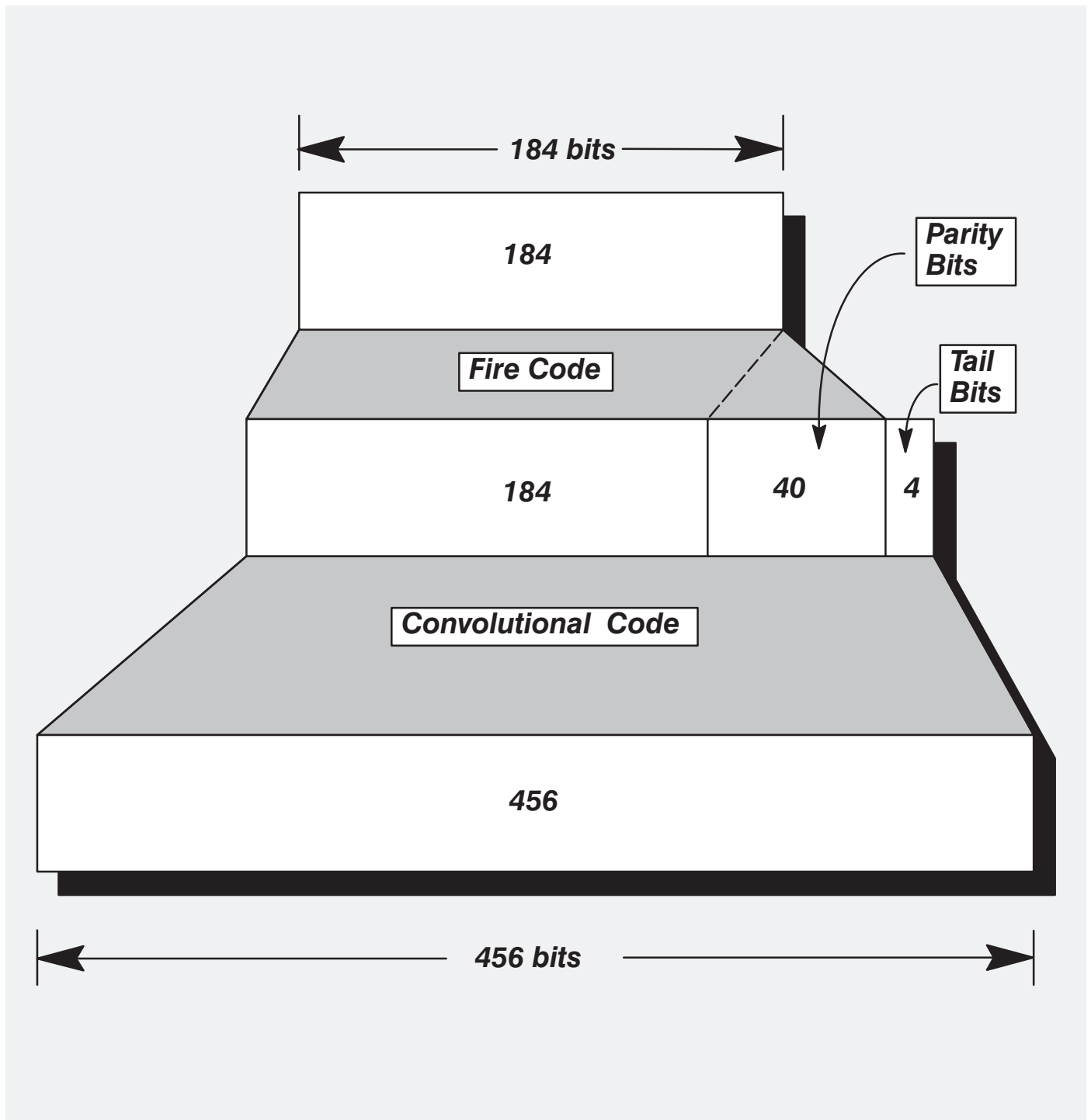

Data Channel Encoding

The diagram opposite shows the principle of the error protection for the 9.6 kbit/s data channel. The other data channels at rates of 4.8 kbit/s and 2.4 kbit/s are encoded slightly differently, but the principle is the same.

Data channels are encoded using a convolutional code only. With the 9.6 kbit/s data some coded bits need to be removed (*punctuated*) before interleaving, so that like the speech and control channels they contain 456 bits every 20 ms.

The data traffic channels require a higher net rate ('net rate' means the bit rate before coding bits have been added) than their actual transmission rate. For example, the 9.6 kbit/s service will require 12 kbit/s, because status signals (such as the RS-232 DTR (Data Terminal Ready) have to be transmitted as well.

The output from the encoding process for each block of 240 bits of data traffic is 456 bits, exactly the same as for speech and control. The resulting 456 bit block is then interleaved before being sent over the air interface.

Note:

Over the PCM link 240 bits were transmitted in 20 ms equalling a transmission rate of 12 kbit/s. 9.6 kbit/s raw data and 2.4 kbit/s signalling information.

The encoded control information now occupies 456 bits but is still transmitted in 20 ms thus raising the transmission rate to 22.8 kbit/s.

Data Channel Encoding

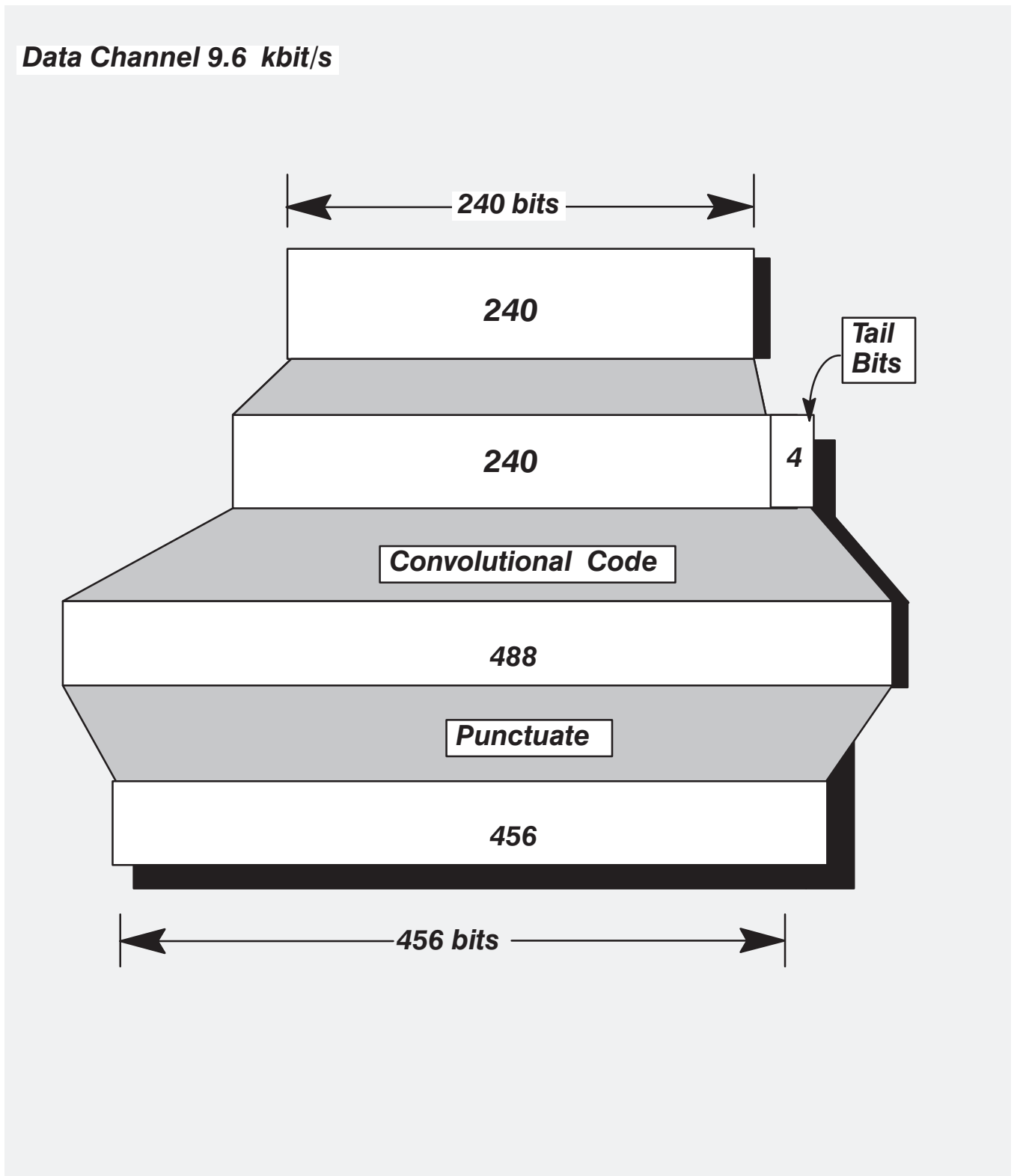

Mapping Logical Channels onto the TDMA Frame Structure

Interleaving

Having encoded, or error protected the logical channel, the next step is to build its bitstream into bursts that can then be transmitted within the TDMA frame structure. It is at this stage that the process of interleaving is carried out. Interleaving spreads the content of one traffic block across several TDMA timeslots. The following interleaving depths are used:

- Speech – 8 blocks
- Control – 4 blocks
- Data – 22 blocks

This process is an important one, for it safeguards the data in the harsh air interface radio environment.

Because of interference, noise, or physical interruption of the radio path, bursts may be destroyed or corrupted as they travel between MS and BTS, a figure of 10–20% is quite normal. The purpose of interleaving is to ensure that only some of the data from each traffic block is contained within each burst. By this means, when a burst is not correctly received, the loss does not affect overall transmission quality because the error correction techniques are able to interpolate for the missing data. If the system worked by simply having one traffic block per burst, then it would be unable to do this and transmission quality would suffer.

It is *interleaving* that is largely responsible for the robustness of the GSM air interface, enabling it to withstand significant noise and interference and maintain the quality of service presented to the subscriber.

Interleaving

<i>TRAU Frame Type</i>	<i>Number of GSM Bursts Spread Over</i>
<i>Speech</i>	8
<i>Control</i>	4
<i>Data</i>	22

Note:

TRAU = Transcoder Rate Adaption Unit

Diagonal Interleaving – Speech

The diagram opposite illustrates, in a simplified form, the principle of the interleaving process applied to a full-rate speech channel.

The diagram shows a sequence of 'speech blocks' after the encoding process previously described, all from the same subscriber conversation. Each block contains 456 bits, these blocks are then divided into eight blocks each containing 57 bits. Each block will only contain bits from even bit positions or bits from odd bit positions.

The GSM burst will now be produced using these blocks of speech bits.

The first four blocks will be placed in the even bit positions of the first four bursts. The last four blocks will be placed in the odd bit positions of the next four bursts.

As each burst contains 114 traffic carrying bits, it is in fact shared by two speech blocks. Each block will share four bursts with the block preceding it, and four with the block that succeeds it, as shown. In the diagram block 5 shares the first four bursts with block 4 and the second four bursts with block 6.

Diagonal interleaving – Speech

Full-rate speech blocks from one conversation arrive after encoding. They each contain 456 bits.

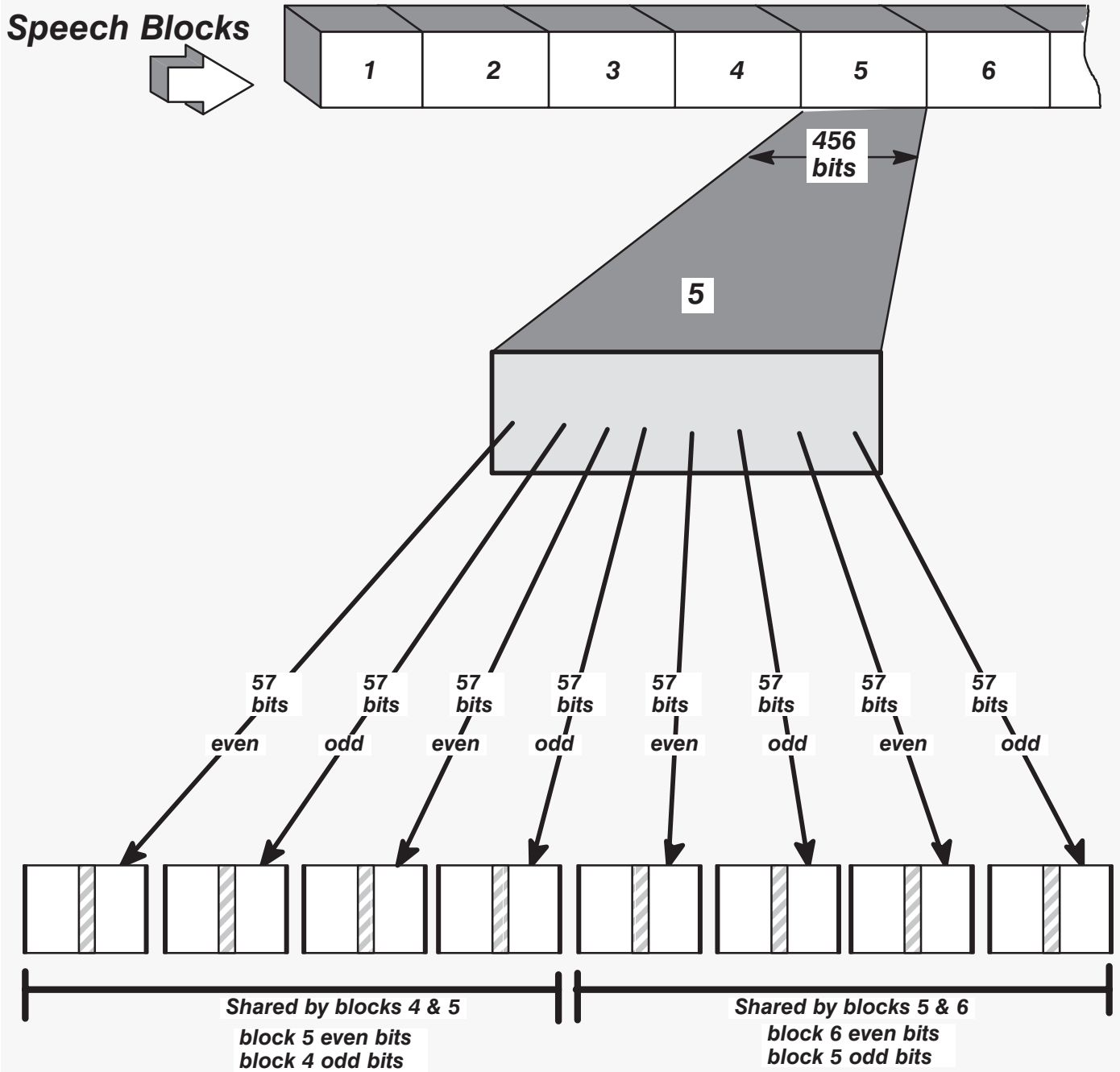

Transmission – Speech

Each burst will be transmitted in the designated timeslot of eight consecutive TDMA frames, providing the interleaving depth of eight.

The diagram opposite shows how successive bursts from this particular subscriber conversation are transmitted. The subscriber is allocated timeslot 4 of the TDMA frame; it will share this frame with up to seven other subscribers.

It is important to remember that each timeslot on this carrier may be occupied by a different channel combination: traffic, broadcast, dedicated or combined.

Note that FACCH, because it 'steals' speech bursts from a subscriber channel, experiences the same kind of interleaving as the speech data that it replaces (interleaving depth = 8). The FACCH will steal a 456 bit block and be interleaved with the speech. Each burst containing a FACCH block of information will have the appropriate stealing flag set.

Diagonal Interleaving – Speech

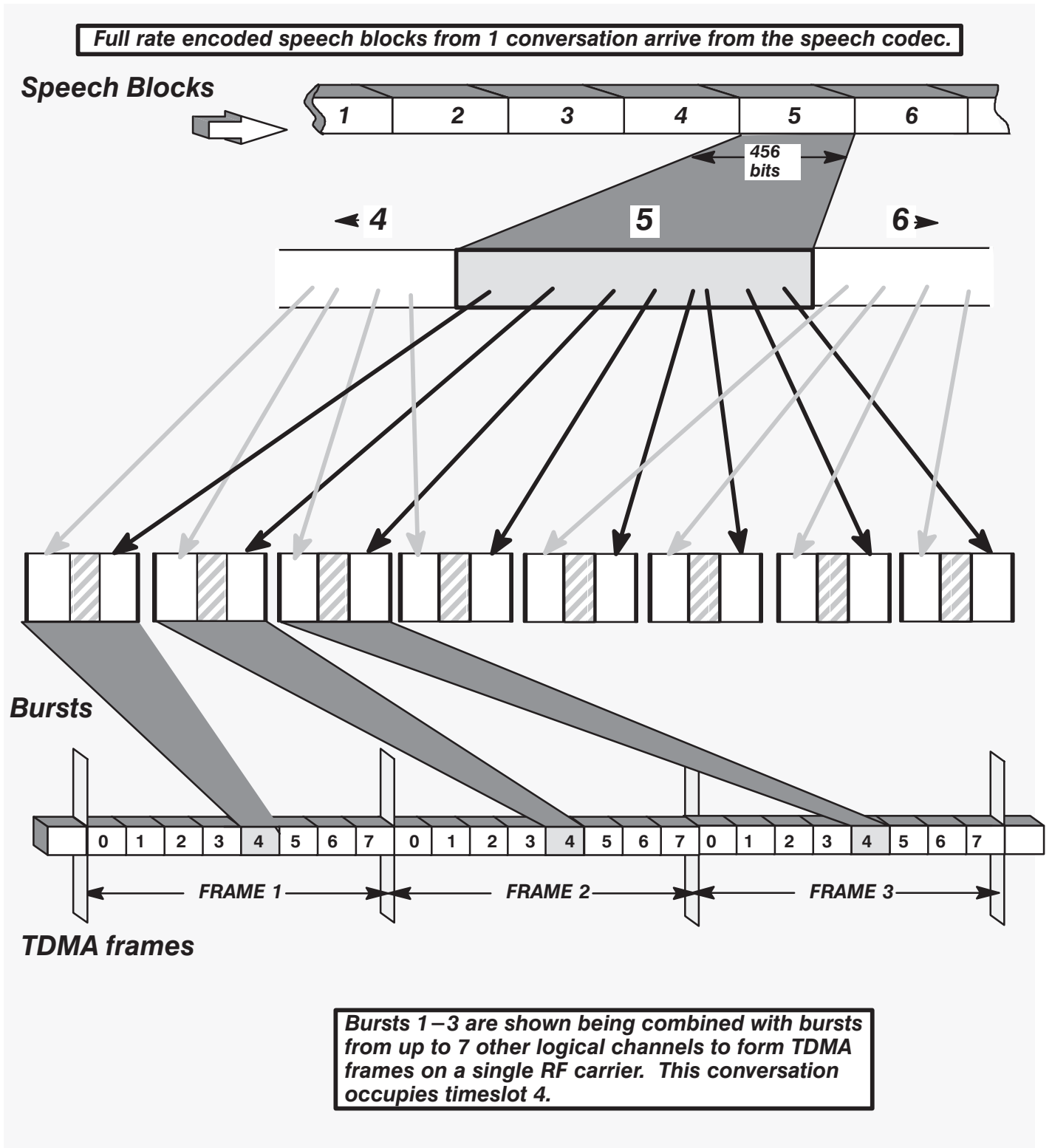

Rectangular Interleaving – Control

The diagram opposite illustrates, in a simplified form, the principle of rectangular interleaving. This is applied to most control channels.

The diagram shows a sequence of 'control blocks' after the encoding process previously described. Each block contains 456 bits, these blocks are then divided into four blocks each containing 114 bits. Each block will only contain bits for even or odd bit positions.

The GSM burst will be produced using these blocks of control.

Transmission – Control

Each burst will be transmitted in the designated timeslot of four consecutive TDMA frames, providing the interleaving depth of four.

The control information is not diagonally interleaved as are speech and data. This is because only a limited amount of control information is sent every multiframe. If the control information was diagonally interleaved, the receiver would not be capable of decoding a control message until at least two multiframe were received. This would be too long a delay.

Rectangular Interleaving – Control

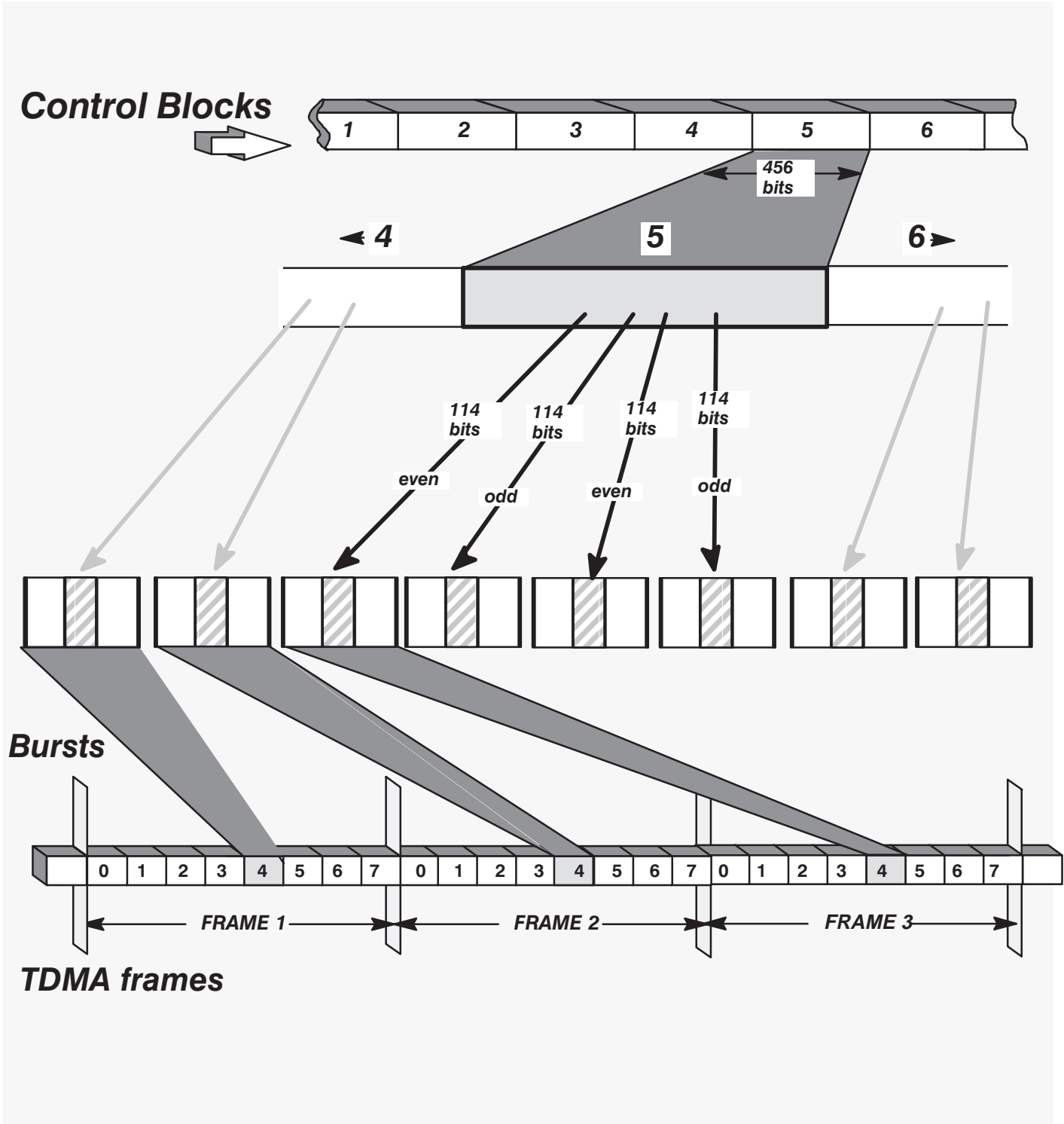

Diagonal Interleaving – Data

The diagram opposite illustrates, in a simplified form, diagonal interleaving applied to a 9.6 kbit/s data channel.

The diagram shows a sequence of 'data blocks' after the encoding process previously described, all from the same subscriber. Each block contains 456 bits, these blocks are divided into four blocks each containing 114 bits. These blocks are then interleaved together.

The first 6 bits from the first block are placed in the first burst. The first 6 bits from the second block will be placed in the second burst and so on. Each 114 bit block is spread across 19 bursts and the total 456 bit block will be spread across 22 bursts.

Data channels are said to have an interleaving depth of 22, although this is sometimes also referred to as an interleaving depth of 19.

Transmission – Data

The data bits are spread over a large number of bursts to ensure that the data is protected. Therefore, if a burst is lost, only a very small amount of data from one data block will actually be lost. Due to the error protection mechanisms used, the lost data can be reproduced at the receiver.

This wide interleaving depth, although providing a high resilience to error, does introduce a time delay in the transmission of the data. If data transmission is slightly delayed, it will not effect the reception quality, whereas with speech, if a delay were introduced this could be detected by the subscriber. This is why speech uses a shorter interleaving depth.

Diagonal Interleaving – Data

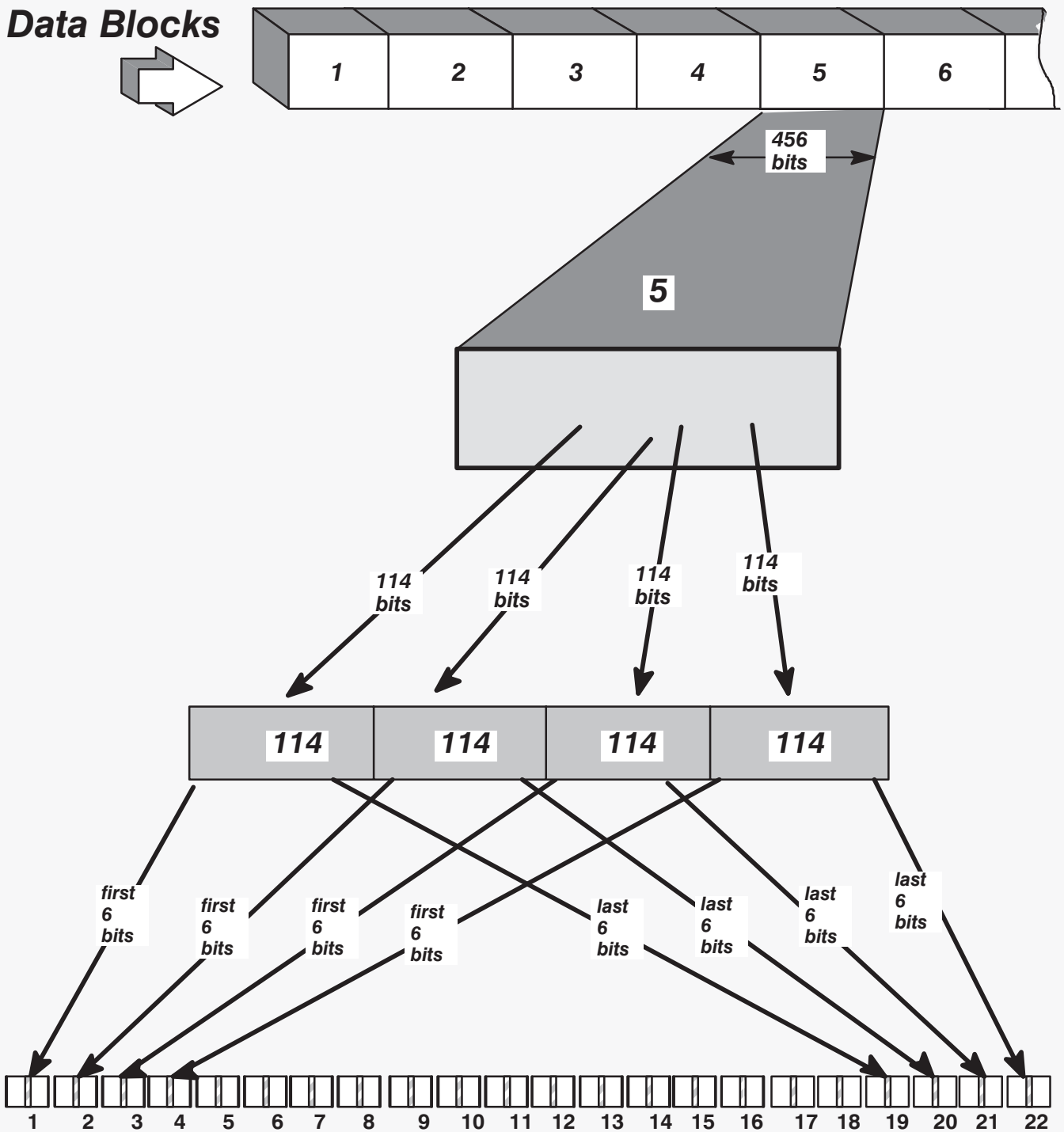

Chapter 7

Radio Interface Optimization

Chapter 7	
Radio Interface Optimization	i
Radio Interface Optimization	7-1
Section Objectives	7-1
Transmission Timing	7-2
Battery Life	7-4
Introduction	7-4
Power Control	7-4
Voice Activity Detection (VAD)	7-6
Overview	7-6
Discontinuous Transmission (DTX)	7-6
Discontinuous Reception (DRX)	7-8
Multipath Fading	7-10
Equalization	7-12
Diversity	7-14
Frequency Hopping	7-16
Introduction	7-16

Radio Interface Optimization

Section Objectives

On completion of this section the student will be able to:

- Know the methods used to combat the following problems using GSM.
 - Transmission Timing
 - Multipath Fading
 - Battery Life

Transmission Timing

To simplify the design of the MS, the GSM specifications specify an offset of three timeslots between the BSS and MS timing, thus avoiding the necessity for the MS to transmit and receive simultaneously. The diagram opposite illustrates this.

The synchronization of a TDMA system is critical because bursts have to be transmitted and received within the "real time" timeslots allotted to them. The further the MS is from the base station then, obviously, the longer it will take for the bursts to travel the distance between them. The GSM BTS caters for this problem by instructing the MS to advance its timing ((that is, transmit earlier) to compensate for the increased propagation delay.

This advance is then superimposed upon the three timeslot nominal offset.

The timing advance information is sent to the MS twice every second using the SACCH.

The maximum timing advance is approximately 233 μ s. This caters for a maximum cell radius of approximately 35 km.

Timing Advance

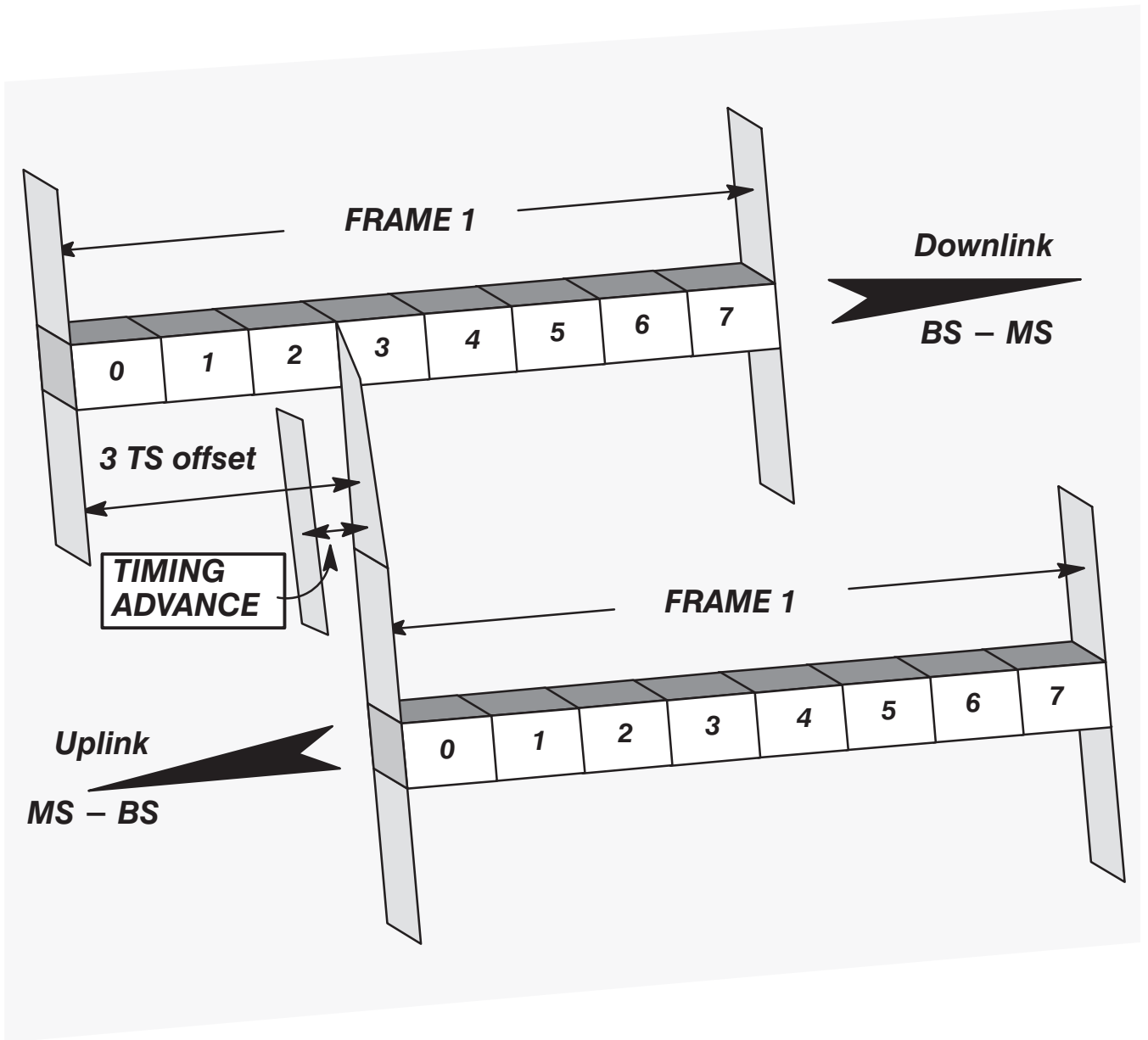

Battery Life

Introduction

One of the main factors which restrict reducing the size of a MS is the battery.

A battery must be large enough to maintain a telephone call for an acceptable amount of time without needing to be recharged. Since there is demand for MSs to become smaller and lighter the battery must also become smaller and lighter.

Four features which enable the life of a GSM MS battery to be extended.

- Power Control
- Voice Activity Detection (VAD)
- Discontinuous Transmission (DTX)
- Discontinuous Reception (DRX)

Power Control

This is a feature of the GSM air interface which allows the network provider to not only compensate for the distance from MS to BTS as regards timing, but can also cause the BTS and MS to adjust their power output to take account of that distance also. The closer the MS is to the BTS, the less the power it and the BTS will be required to transmit. This feature saves radio battery power at the MS, and helps to reduce co-channel and adjacent channel interference.

Both uplink and downlink power settings can be controlled independently and individually at the discretion of the network provider.

Initial power setting for the MS is set by the information provided on the Broadcast Control Channel (BCCH) for a particular cell.

The BSS controls the transmit power of both the MS and the BTS. The received MS power is monitored by the BSS and the receive BTS power is monitored by the MS and then reported to the BSS. Using these measurements the power of both MS and BTS can be adjusted accordingly

Power Control

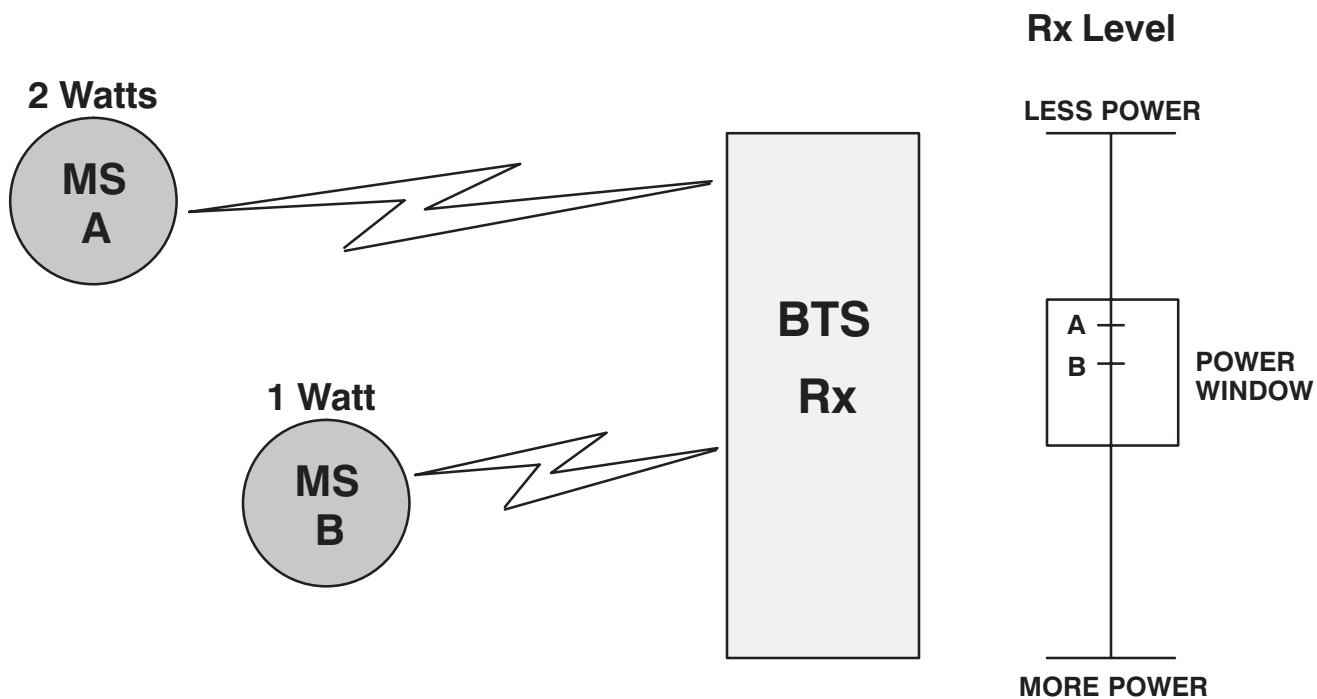

Note:

The BTS will adjust the Tx power of each MS to ensure that the Rx signal at the BTS is maintained within the defined power window.

Voice Activity Detection (VAD)

Overview

VAD is a mechanism whereby the source transmitter equipment identifies the presence or absence of speech.

VAD implementation is effected in speech mode by encoding the speech pattern silences at a rate of 500 bit/s rather than the full 13 kbit/s. This results in a data transmission rate for background noise, known as "comfort" noise, which is regenerated in the receiver.

Without "comfort" noise the total silence between the speech would be considered to be disturbing by the listener.

Discontinuous Transmission (DTX)

DTX increases the efficiency of the system through a decrease in the possible radio transmission interference level. It does this by ensuring that the MS does not transmit unnecessary message data. DTX can be implemented, as necessary, on a call by call basis. The effects will be most noticeable in communications between two MS.

DTX in its most extreme form, when implemented at the MS can also result in considerable power saving. If the MS does not transmit during 'silences' there is a reduction in the overall power output requirement.

The implementation of DTX is very much at the discretion of the network provider and there are different specifications applied for different types of channel usage.

DTX is implemented over a SACCH multiframe (480 ms). During this time, of the possible 104 frames, only the 4 SACCH frames and 8 Silence Descriptor (SID) frames are transmitted.

VAD & DTX

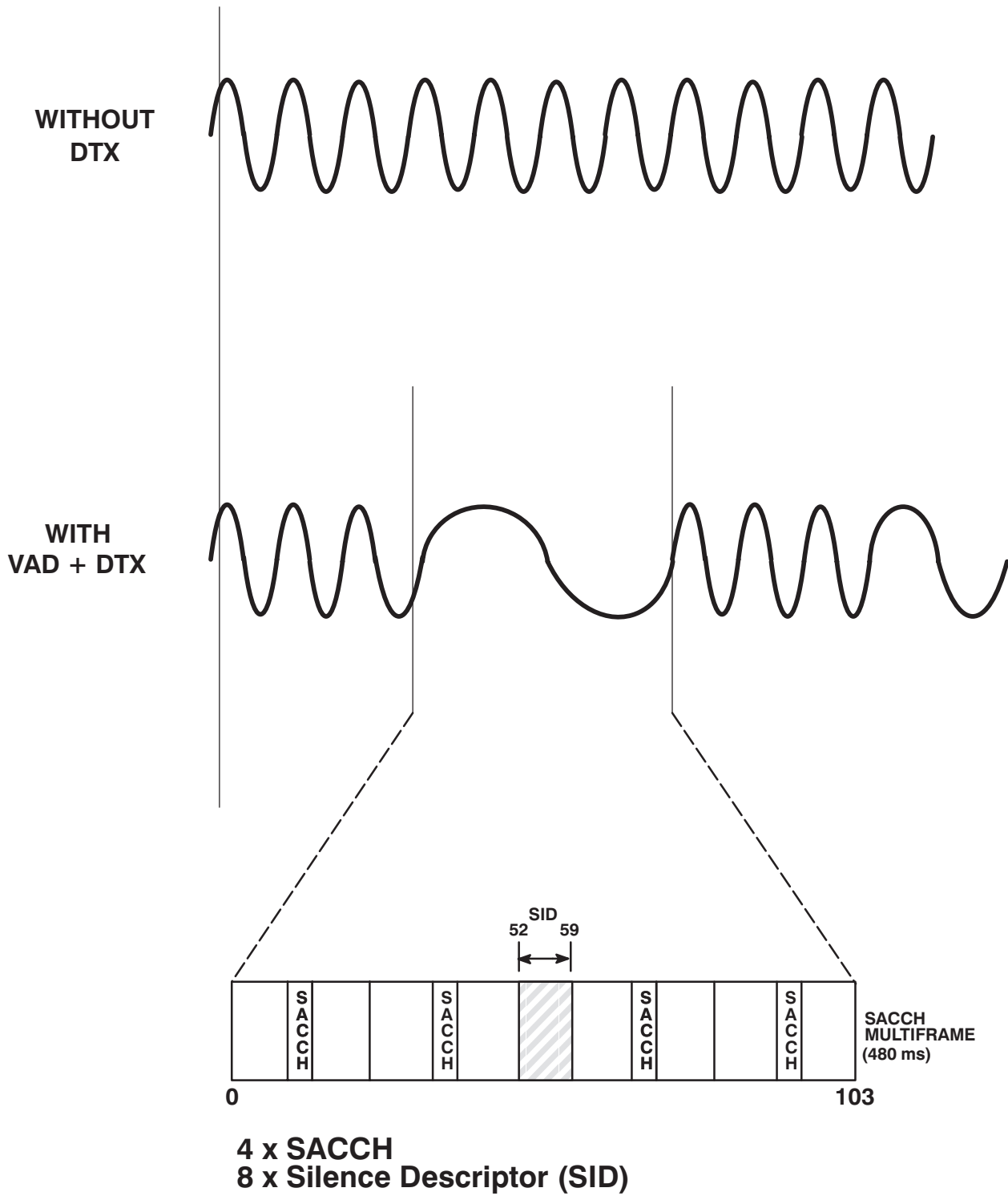

Discontinuous Reception (DRX)

DRX allows the MS to effectively “switch off” during times when reception is deemed unnecessary.

By monitoring the Broadcast Control Channel (BCCH), the Frequency Correction Control Channel (FCCH) and the Synchronisation Control Channel (SCCH) the MS is aware of the Frame Number and repetition format for Frame Synchronization. It can therefore, after initially locking on to a BCCH, determine when the next relevant information is to be transmitted. This allows the MS to ‘go to sleep’ and listen-in only when necessary, with the effective saving in power usage.

DRX may only be used when a MS is not in a call.

When DRX is employed, the MS using information broadcast on the BCCH determines its “paging group”. The paging group may appear once during a control channel multiframe, or may only be scheduled to appear once over several multiframe – the rate of repetition is determined by the network provider and it is this information which is broadcast over the BCCH, which allows the MS to determine its paging group.

DRX

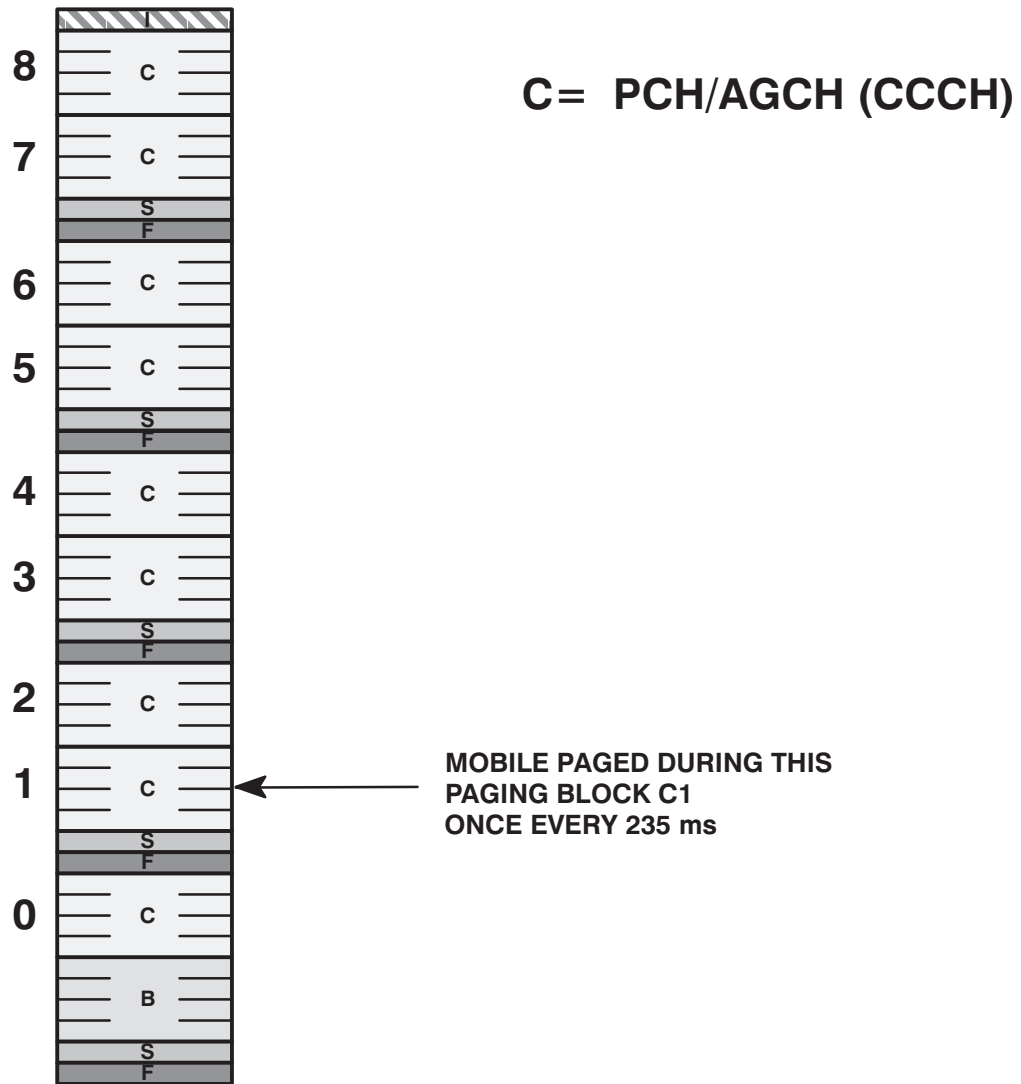

OPTIONALLY: The MS may be paged once over a number of multiframes

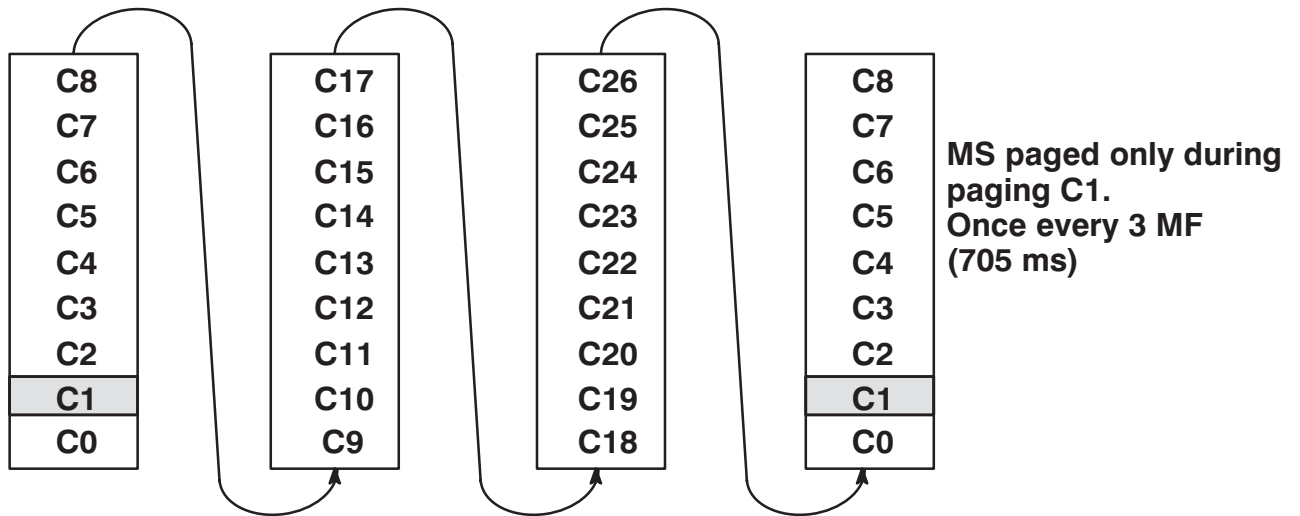

Multipath Fading

Multipath Fading results from a signal travelling from a transmitter to a receiver by a number of routes. This is caused by the signal being reflected from objects, or being influenced by atmospheric effects as it passes, for example, through layers of air of varying temperatures and humidity.

Received signals will therefore arrive at different times and not be in phase with each other, they will have experienced time dispersion. On arrival at the receiver, the signals combine either constructively *or* destructively, the overall effect being to add together or to cancel each other out. If the latter applies, there may be hardly any usable signal at all. The frequency band used for GSM transmission means that a “good” location may be only 15 cm from a “bad” location!

When the receive antenna is moving, the exact phase of each path changes and consequently the combined signal-strength is also continually changing. When the antenna is moving rapidly, this loss is recovered by interleaving and channel coding. When it is slow moving or stationary however, the receiver may be in a “null” (point of minimum signal) for several consecutive frames.

The diagram opposite shows a few routes by which a pulse of radio energy might be propagated from a base station to a mobile.

Each has suffered varying losses in transmission (path attenuation), hence the variety of amplitudes. A typical urban profile would cause dispersion of up to 5 microseconds, whereas, a hilly terrain would cause dispersion of up to 20 microseconds.

GSM offers five techniques which combat multipath fading effects:

- Equalization.
- Diversity.
- Frequency hopping.
- Interleaving.
- Channel coding.

The equalizer must be able to cope with a dispersion of up to 17 microseconds.

Multipath Fading

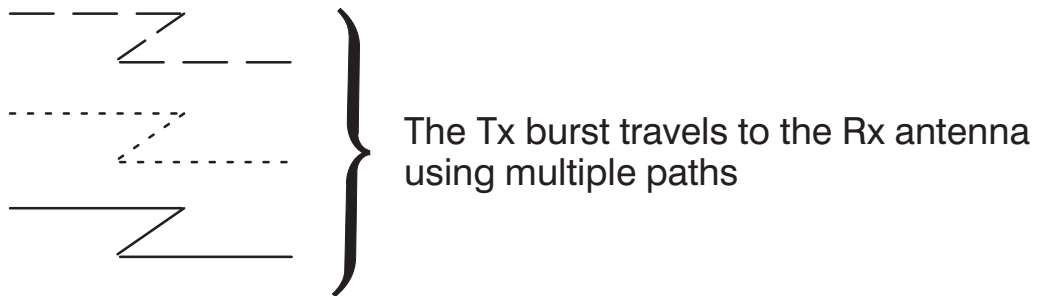
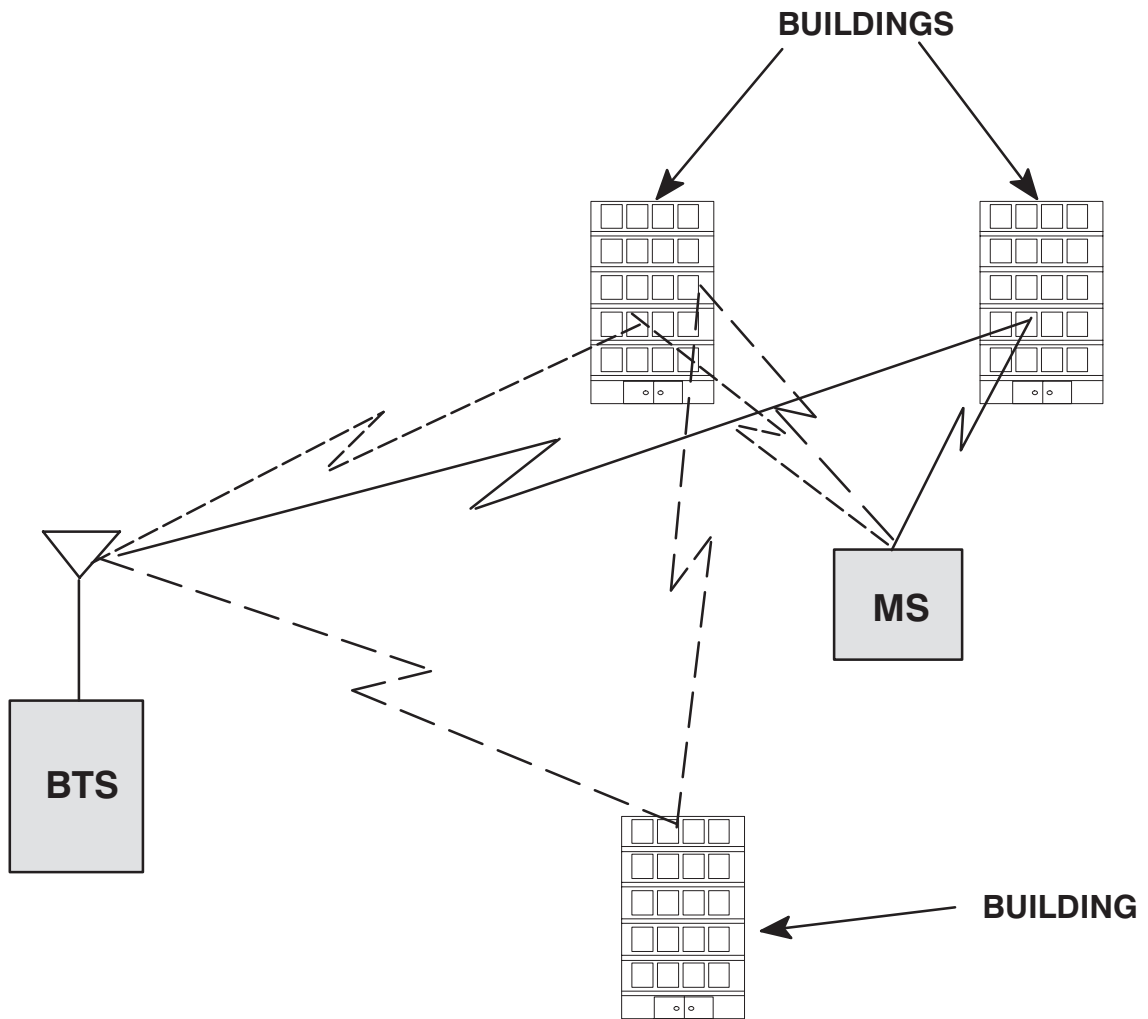

Equalization

Due to the signal dispersion caused by multipath signals the receiver cannot be sure exactly when a burst will arrive and how distorted it will be. To help the receiver identify and synchronize to the burst, a Training Sequence is sent at the centre of the burst. This is a set sequence of bits which is known by both the transmitter and receiver.

When a burst of information is received, the equalizer searches for the training sequence code. When it has been found, the equaliser measures and then mimics the distortion which the signal has been subjected to. The equalizer then compares the received data with the distorted possible transmitted sequences and chooses the most likely one.

There are eight different Training Sequence codes numbered 0–7. Nearby cells operating with the same RF carrier frequency will use different Training Sequence Codes to enable the receiver to discern the correct signal.

Training Sequence Code

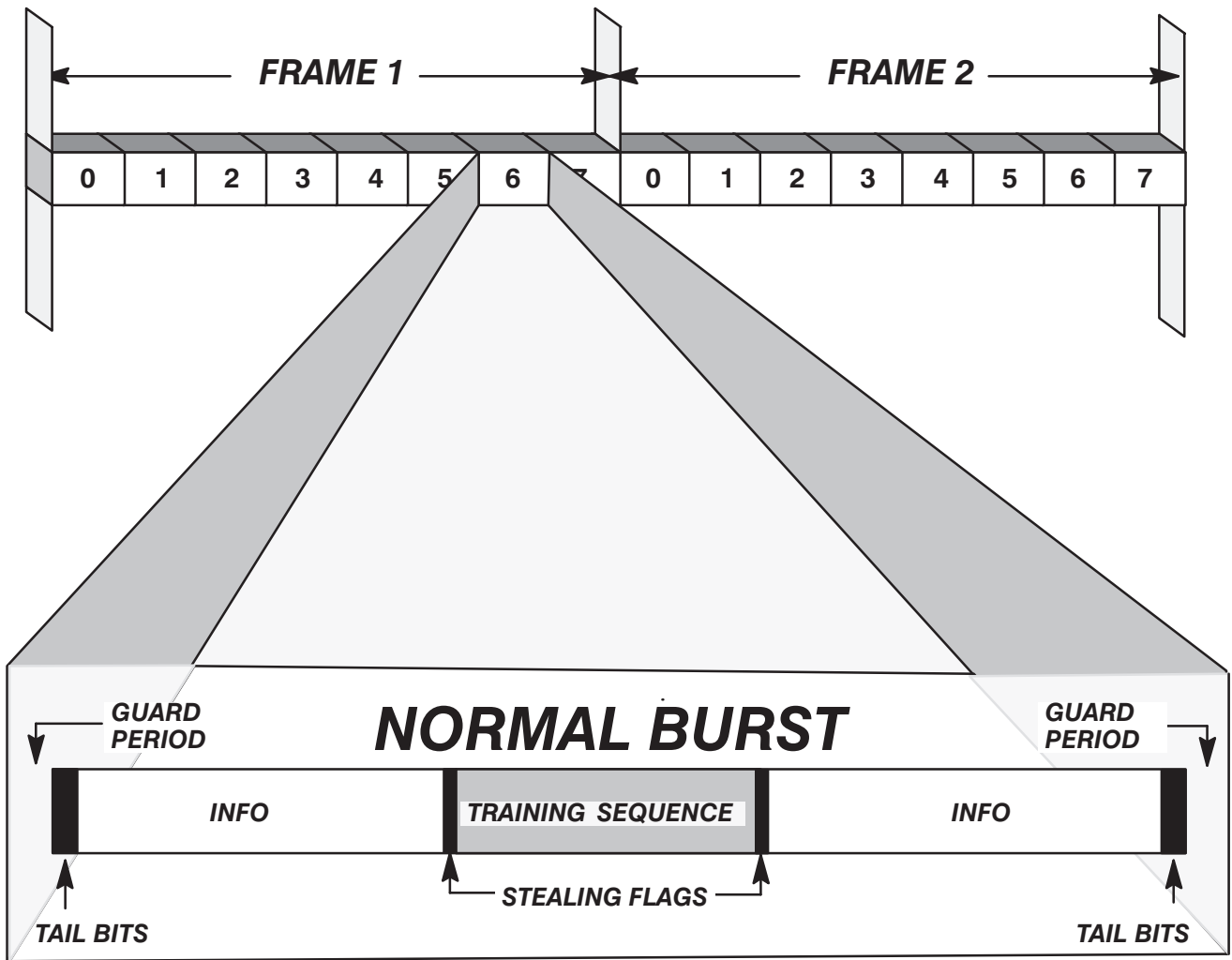

Diversity

Signals arrive at the receive antenna from multiple paths. The signals are therefore received by the antenna at different phases, some at a peak and some at a trough. This means that some signals will add together to form a strong signal, while others will subtract causing a weak signal.

When diversity is implemented, two antennas are situated at the receiver. These antennas are placed several wavelengths apart to ensure minimum correlation between the two receive paths. The two signals are then combined and the signal strength improved.

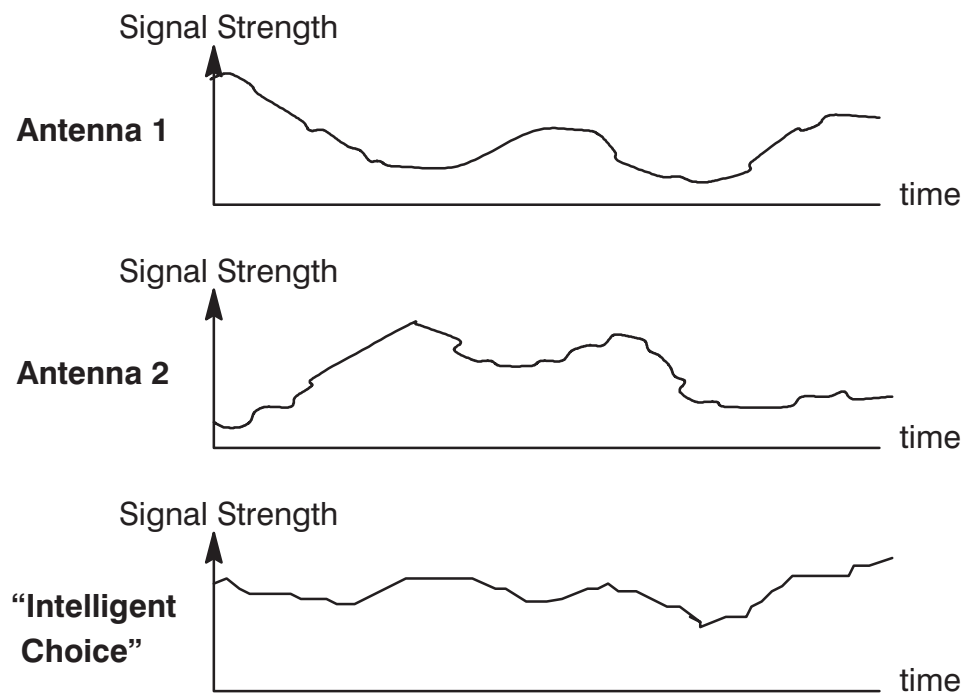

Diversity

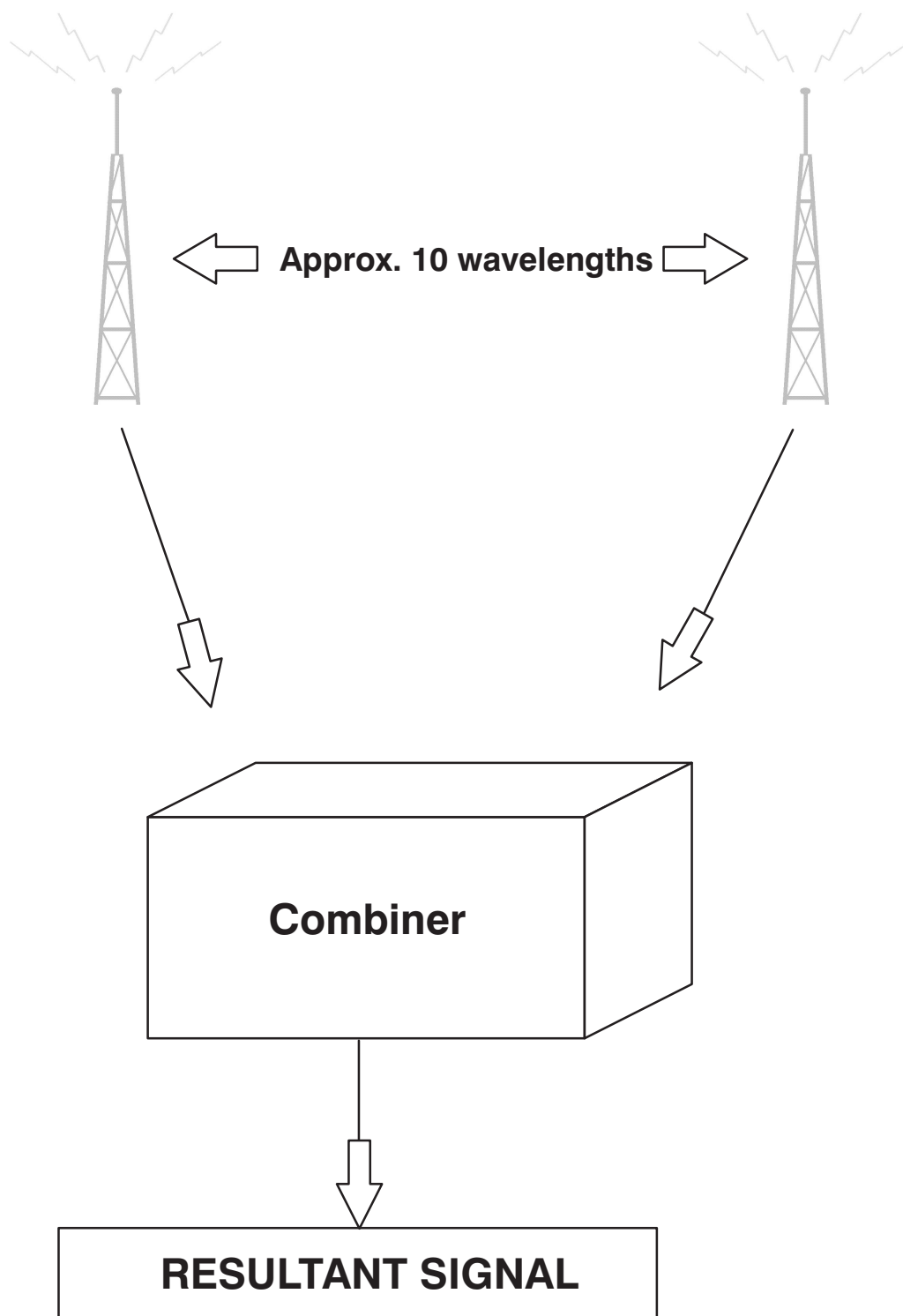

Frequency Hopping

Introduction

Frequency hopping allows the RF channel used for carrying signalling channel timeslots or traffic channel (TCH) timeslots to change frequency every frame (or 4.615 msec). This capability provides a high degree of immunity to interference, due to the effect of interference averaging, as well as providing protection against signal fading.

The effective "radio channel interference averaging" assumes that radio channel interference does not exist on every allocated channel and the RF channel carrying TCH timeslots changes to a new allocated RF channel every frame. Therefore, the overall received data communication experiences interference only part of the time.

All mobile subscribers are capable of frequency hopping under the control of the BSS. To implement this feature, the BSS software must include the frequency hopping option. Cyclic or pseudo random frequency hopping patterns are possible, by network provider selection.

Frequency Hopping

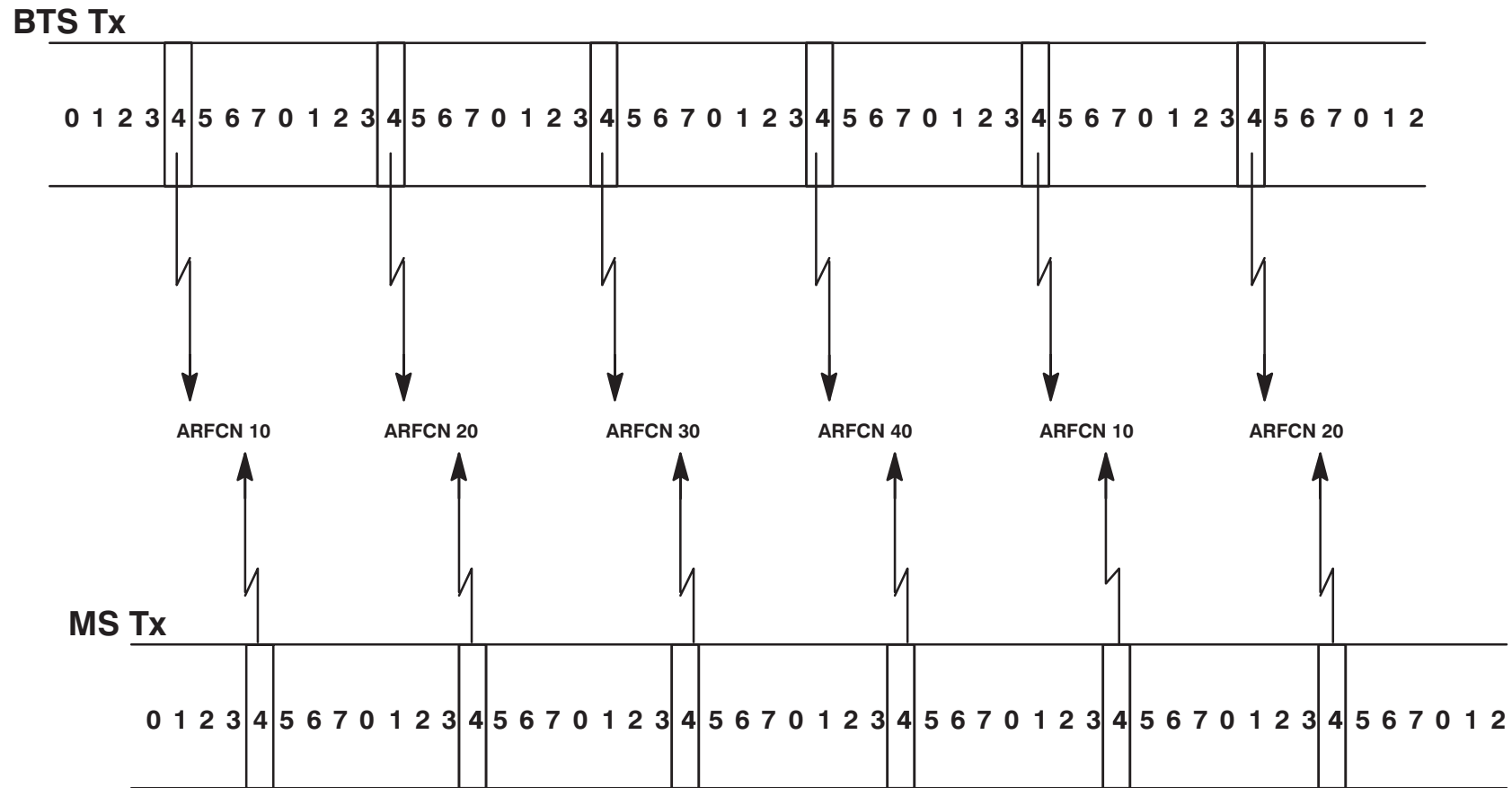

Cyclic frequency hopping using ARFCN's 10, 20, 30 and 40

Chapter 8

Introduction to Microcellular

Chapter 8	
Introduction to Microcellular	i
Introduction to Microcellular	8-1
Section Objectives	8-1
Introduction	8-2
What is Microcell?	8-2
Why Deploy Microcells?	8-2
How are Microcells Deployed?	8-4
Building Penetration from Externally Mounted Cells	8-6
Antenna Types	8-8
Directional Antennas	8-8
Omni Antennas	8-8
The Microcellular Solution	8-10
Picocells	8-12

Introduction to Microcellular

Section Objectives

On completion of this section the student will be able to:

- understand what a microcell is and how they may be employed.
- understand the advantages of microcellular over other capacity enhancement techniques.

Introduction

What is Microcell?

The term microcell suggests a small cell. This is true, but microcells are defined as cells for which the antennas are mounted below local rooftop level. This helps contain the microcells RF radiation to within the street canyons.

Why Deploy Microcells?

At present 80 to 90% of the current worldwide GSM subscribers fall into one category, that of slow moving and stationary handportable units (class 4 mobiles).

Microcellular Concept

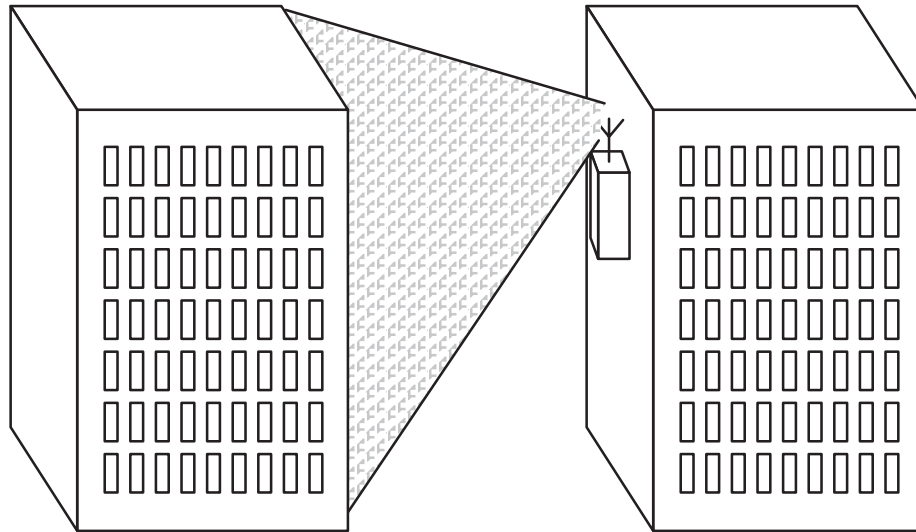

The Microcellular principle has applications in:

- **GSM, DCS, PCS**
- **Urban areas**
- **In building systems**

Microcellular offers independence of:

- **Frequency** (using existing networks ARFCN's)
- **Technology base** (i.e. Any existing or future hardware)
- **Products** (for example, Motorola microcells under another vendors macrocells)

How are Microcells Deployed?

By placing the antenna below the rooftop, the RF propagation can be contained. This allows the frequency reuse within the microcells coverage area to be tighter than in the existing network. This means greater spectrum efficiency. The microcells are also deployed underneath the existing network. This introduces the term, layered architecture. This would suggest that the current system cells become "umbrella or macrocells". Therefore, in the area of macro- and microcell coverage we have enhanced capacity. We can now say that the microcells have introduced better capacity and spectrum efficiency.

We could also assume that any areas of poor or no coverage in the existing network could also be overcome by the use of microcells. This would mean that microcells can provide greater:

- Capacity
- Coverage
- Spectrum efficiency

or

- Erlangs
- Km²
- MHz

Note:

One Erlang is a measure of one traffic channel permanently utilized.

Layered Architecture

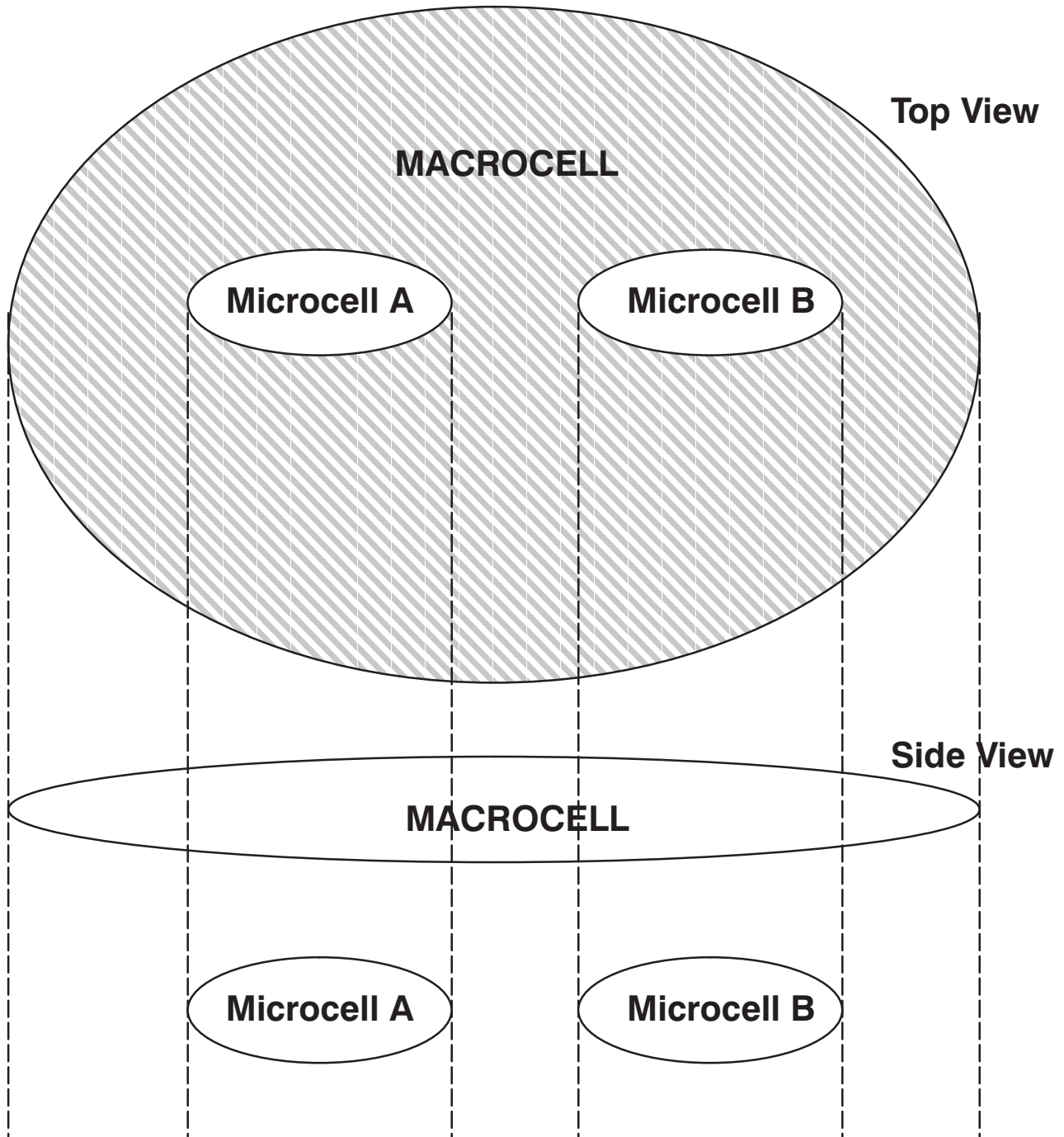

Building Penetration from Externally Mounted Cells

For a cell with an outdoor mounted antenna, path loss defines the limit of possible coverage, including building penetration losses and “on-street” path loss. This suggests that, as the distance from the antenna increases, the depth of penetration into buildings will reduce.

There may be situations where a building further away has better indoor coverage, for example, due to the fact that the angle of incidence to the building is more favourable for better penetration. The level of penetration into a building depends on a number of factors some of which are:

- Building material.
- Number of windows.
- Angle of incidence.
- Internal structure.

A microcell could give enhanced coverage within a building, even if it is deployed primarily as an external or on-street microcell. This aids providing the user with greater coverage.

Microcells may even be deployed within buildings, especially in larger indoor areas (for example, conference centres etc.).

Building Penetration from Externally Mounted Cells

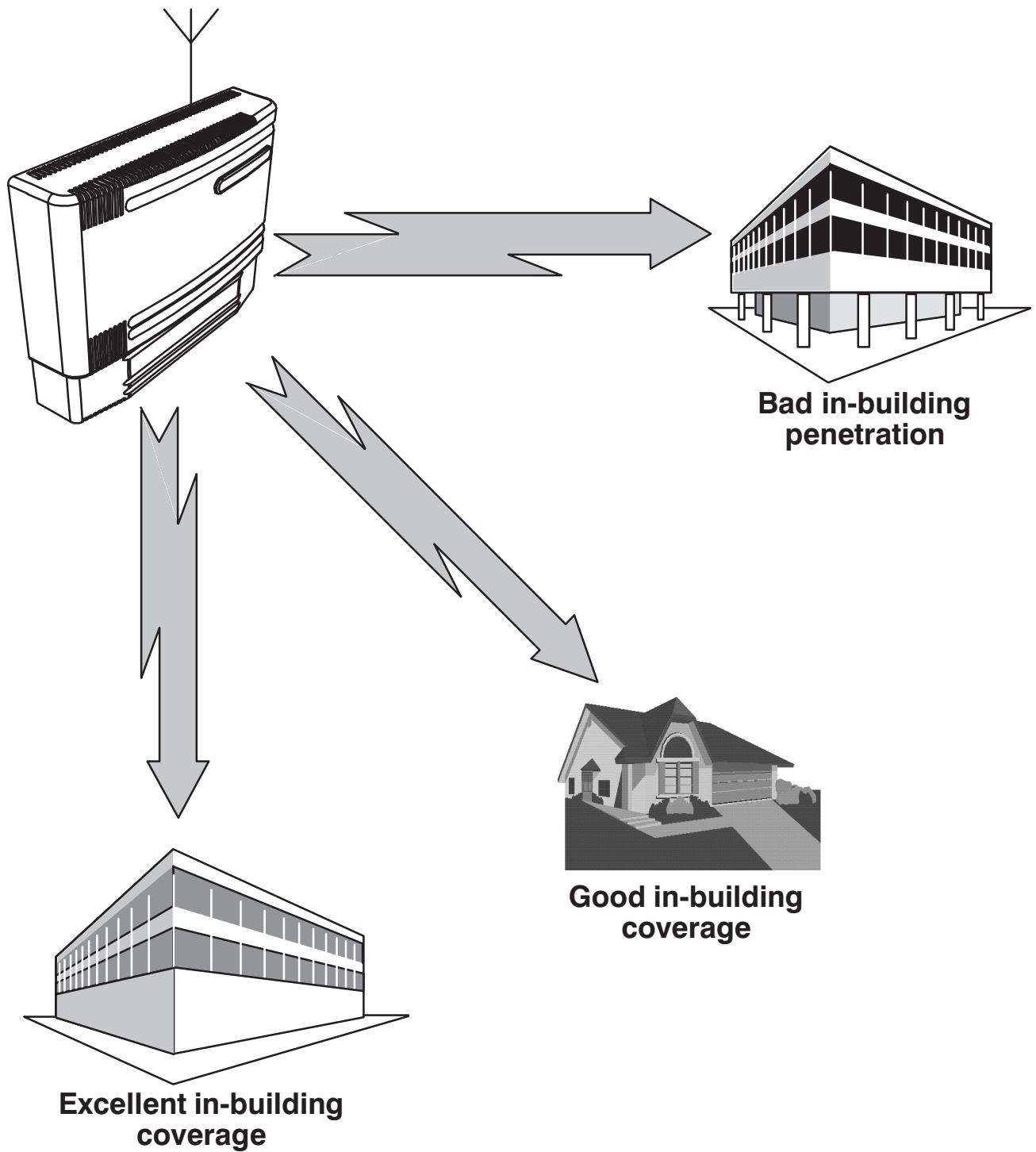

Antenna Types

Both directional and omni-directional antennas have their uses in a microcellular system. The different attributes of these antennas can be used by the cell planners to avoid shadows, reduce handover requests, and maximize call success.

Directional Antennas

Directional antennas are useful for covering long streets and have the following advantages:

- Extra gain in the forward direction.
- Suppressed signal in the reverse direction, this is a useful characteristic if the cell is a potential interferer with another cell located behind it.

It is also worth noting that a directional antenna could be used to improve in-building coverage, in specific buildings, within the microcell area.

Omni Antennas

Omni antennas are useful for covering open areas (for example squares, plazas). In these areas, it is desirable to have a clearly designated 'best server' cell to avoid excessive handovers and their attendant problems.

Another application is to create a "corner crossroads" cell. This avoids having transient cells at street crossroads. However, by intersecting with more streets, the potential for interference with other cells may be increased.

Antenna Types

Directional Antennas

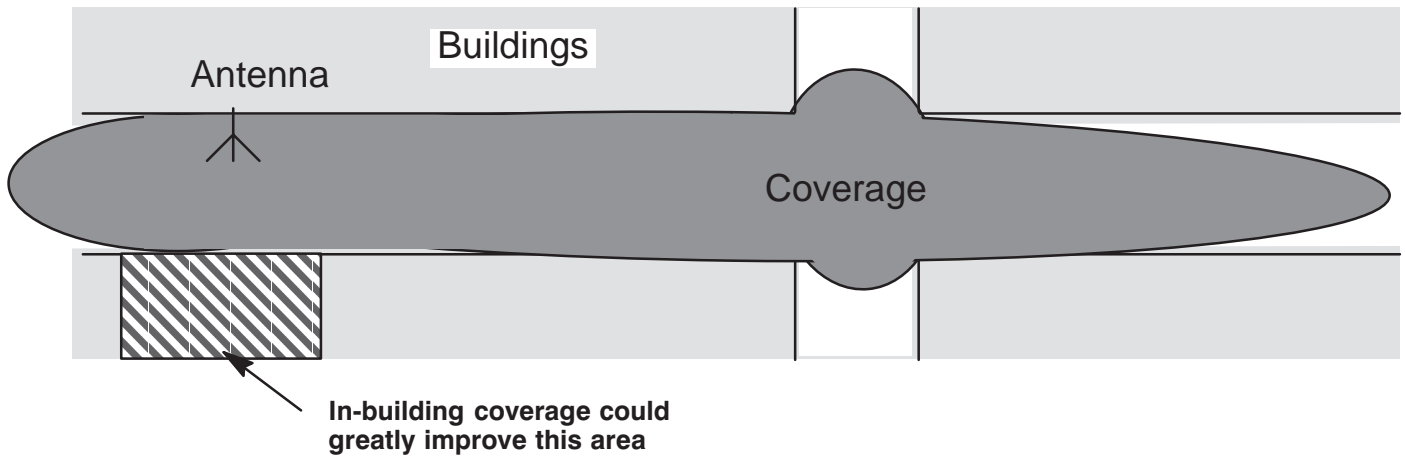

Omnni Antennas

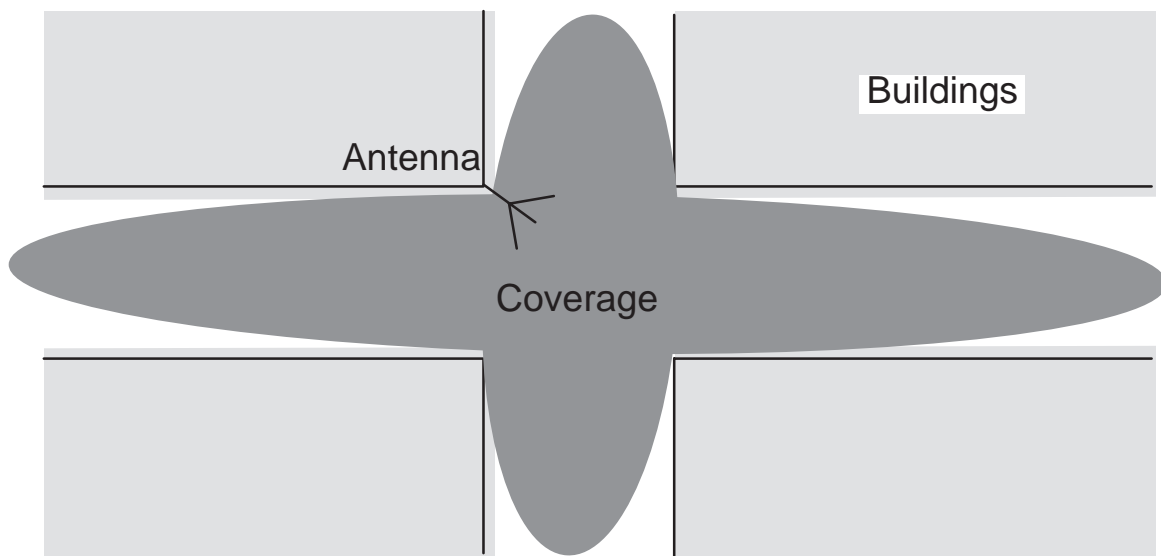

The Microcellular Solution

As the GSM network has evolved and matured, its traffic loading has increased as the number of subscribers has grown. Eventually, the network could reach a point of traffic saturation. The use of microcells can provide high traffic capacity in localized areas.

The use of microcells can alleviate the increase in congestion. Microcells could be stand-alone cells to cover traffic "hotspots" or a contiguous coverage of cells in a combined architecture.

The Microcellular Solution

- **Increased capacity and better coverage**
- **Microcell coverage will provide better coverage where conventional macrocells do not (blackspots)**
- **On-street cells will in some case have better in-building penetration than macrocells**
 - **dependant on individual site location etc.**
- **Specific in-building cells may be implemented**
- **Microcells can be used to supplement channel capacity in areas of rapid traffic growth**
- **Microcells offer ways of effectively covering areas of non-homogenous traffic**
- **Increased spectral efficiency**

Picocells

The future capacity and coverage requirements of a network may require the introduction of indoor cellular coverage. This may be provided by picocells. Picocells could offer further capacity, coverage and quality enhancement to a network which has already deployed microcells to provide on street coverage and capacity.

Picocells

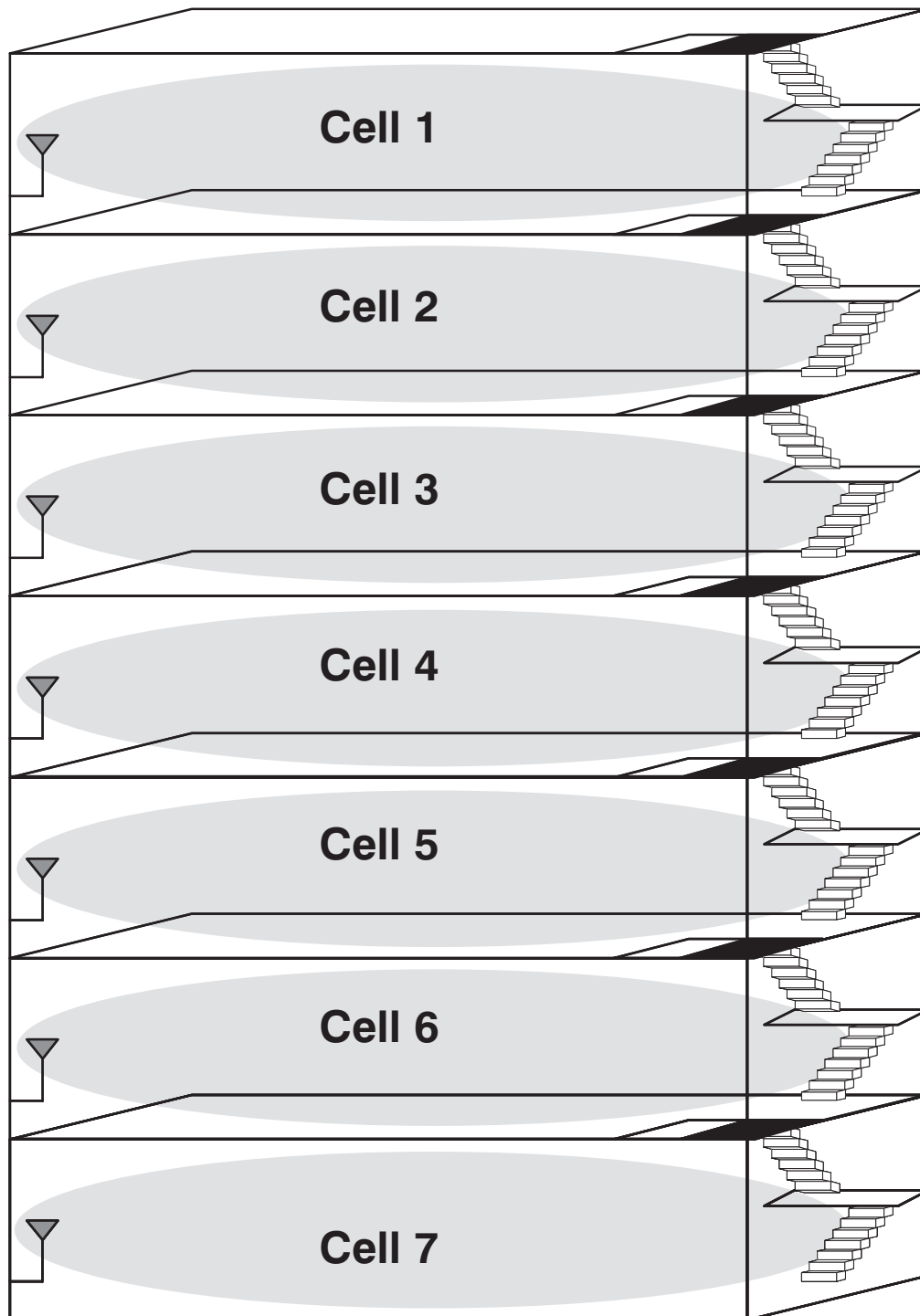

Each floor could have its own cell allowing MS to establish a call on the top floor and maintain it whilst moving between floors.



CP02 Exercise

Exercise

Please answer all questions on the answer sheet provided.

1. Which network component provides switching and connection to other networks such as PSTN?
 - A. Operation and Maintenance Centre
 - B. Network Management Centre
 - C. Base Station System
 - D. Mobile Services Switching Centre

2. There are five criteria used by GSM to perform handovers, RF level, MS distance and power budget are three, but what are the other two?
 - A. Quality and power class of the mobile
 - B. Quality and interference
 - C. Interference and short message services
 - D. Power class of the mobile and short message services

3. What feature will GSM use to double the number of traffic channels for the same bandwidth?
 - A. Discontinuous transmission
 - B. Half rate speech
 - C. Higher data rates
 - D. Phase two phones

4. The BSS has three main components, what are they?
 - A. MS, MSC and OMC
 - B. BSC, BTS and XCDR
 - C. BSC, SCDR and MSC
 - D. MSC, HLR and VLR

-
5. The BSC connects _____ circuits to _____ on the air interface. (Fill in the blanks).
- A. The BSC connects DATA circuits to CONTROL BITS on the air interface.
 - B. The BSC connects TERRESTRIAL circuits to FRAMES on the air interface.
 - C. The BSC connects TERRESTRIAL circuits to CHANNELS on the air interface.
 - D. The BSC connects RADIO circuits to CHANNELS on the air interface.
6. The XCDR converts _____ kbps voice circuits to GSM defined _____ kbps channels. (Fill in the blanks).
- A. The XCDR converts 64 kbps voice circuits to GSM defined 16 kbps channels
 - B. The XCDR converts 120 kbps voice circuits to GSM defined 16 kbps channels
 - C. The XCDR converts 9600 kbps voice circuits to GSM defined 2400 kbps channels
 - D. The XCDR converts 64 kbps voice circuits to GSM defined 120 kbps channels
7. Which network elements use the OML signalling link?
- A. MSC and MS
 - B. BSC and BTS
 - C. OMC and BSC
 - D. BTS and MSC
8. The Message Transfer Link (MTL) carries signalling information between the MSC and BSC. Which signalling protocol does the MTL use?
- A. X.25
 - B. LAPB
 - C. C7
 - D. LAPD
9. What type of burst is used to carry Traffic or Control information and is bi-directional?
- A. Frequency correction
 - B. Normal
 - C. Dummy
 - D. Access

10. Which type of coding provides error protection and increases the number of bits to be transmitted by a factor of 1:2?
- A. Speech and data coding
 - B. Encryption coding
 - C. convolutional coding
 - D. Parity bit coding
11. Interleaving spreads the contents of a coded speech or data block over a number of air interface bursts to provide error protection. What type of interleaving is used for speech blocks?
- A. Diagonal
 - B. Rectangular
 - C. Both
 - D. Cyclic
12. What is the maximum timing advance that can be ordered at the mobile station?
- A. 4.615 mS
 - B. 233uS
 - C. 3 timeslots
 - D. 577uS
13. Which one of the following is NOT a technique to combat the effects of multi-path fading?
- A. Frequency hopping
 - B. Equalisation
 - C. Diversity
 - D. Sectorisation

-
14. The duration of a timeslot on the Air Interface is 577uS. What is the duration of a burst?
- A. 20mS
 - B. 577uS
 - C. 546uS
 - D. 4.615mS
15. Which of the following channels carries measurement information from a mobile during a call?
- A. SACCH
 - B. SDCCH
 - C. BCCH
 - D. TCH
16. Which logical channel is used by the mobile station for its first access to the cellular system?
- A. FACCH
 - B. RACH
 - C. SACCH
 - D. AGCH
17. Which timeslots in the TDMA frame can be used to carry DCCH channels?
- A. Any
 - B. Zero
 - C. 1–7
 - D. 0, 2, 4, and 6
18. Which logical channel assigns an SDCCH to a mobile station?
- A. FACCH
 - B. RACH
 - C. SACCH
 - D. AGCH

19. What is the best location for a Microcell antenna?
- A. Outside, below roof top level
 - B. Outside, on top of the roof
 - C. Inside the building
 - D. As close to the BTS as possible
20. What name is given to a cell located inside a building?
- A. Erlang
 - B. Picocell
 - C. Nanocell
 - D. Macrocell

Notes Page

CP02 Introduction to Digital Cellular

Please write clearly and answer all questions on this answer sheet.

Name: _____

Date: _____

Company: _____

Country: _____

Please mark once per question in the relevant box.

QUESTION NUMBER	A	B	C	D
1				
2				
3				
4				
5				
6				
7				
8				
9				
10				
11				
12				
13				
14				
15				
16				
17				
18				
19				
20				

Percentage:



Appendix 1 (GSM History & Organization)

GSM History

Frequency Band Reserved for Cellular (1979)

Due to the increasing use of radio communications throughout Europe, the frequency spectrum was becoming congested and cluttered. Some bandwidth needed to be set aside if a Europe wide cellular system was ever to become a reality. At the World Administrative Radio Conference (WARC) of 1979, the frequency band to be used was agreed upon. Since then, many analogue systems have come into service in Europe (Sweden–1981, UK–1985 etc).

“Groupe Special Mobile” Created Within CEPT (1982)

In 1982, the Conference of European Posts and Telecommunications Administrations (CEPT) established a committee called “Groupe Speciale Mobile” (*GSM*). This committee was set up to specify a unique radio communication system for Europe, this system was to be called GSM. Four working parties were set up to specify the different parts of the GSM system.

“Permanent Nucleus” Established (1986)

The GSM committee met regularly and eventually it was decided that a permanent body was required. In 1986 a small team of full time members was established in Paris. This team were to co-ordinate the working parties and manage the edition and updating of the specifications. (There are now 130 recommendations divided into 12 series)

ETSI takes over GSM (1988)

In 1988 the European Telecommunications Standard Institute (ETSI) was created. This institute took over most of the technical standardization activities of CEPT including GSM. The introduction of ETSI enabled network providers and telecommunications equipment manufacturers to become involved in the specification of GSM. The GSM Recommendations were now renamed the ‘Interim ETSI Technical Specifications’ to comply with the ETSI standards.

Also, in 1988 the first invitations to tender were issued for GSM equipment. Motorola was awarded contracts for validation systems in the UK, Germany, Spain and Scandinavia.

Phase 1 GSM Recommendations Frozen (1990)

The first phase of the Recommendations for GSM were frozen in 1990 to enable development of the first GSM systems.

GSM History

Date	Task Completion
1979	Europe wide frequency band set aside for cellular.
1982	“Groupe Special Mobile” is created within CEPT.
1986	GSM has full time team in Paris.
1988	ETSI takes over GSM Committee. First Tender invitations made.
1990	The phase 1 GSM Recommendations are frozen.

GSM Changes to SMG (1991/1992)

In January 1991 phase 1 issue of DCS 1800 was approved by ETSI–GSM

At the end of 1991 the GSM committee was given responsibility for the next generation of mobile communications equipment. To avoid confusion between the GSM system and the GSM committee with its wider responsibilities, the committee was renamed 'Special Mobile Group' (*SMG*) in 1992. The SMG committees are now responsible for GSM, Digital Communication System (DCS)1800 and the Universal Mobile Telecommunication System (UMTS).

Also during this year, the GSM System was renamed. Rather than being called "Groupe Special Mobile" it was now named "Global System for Mobile Communications". The name was changed to make the product attractive to a world-wide market rather than a Europe-wide market, as was the initial intention. The acronym GSM was retained to avoid confusion.

GSM is launched (1992)

Commercial service for some major cities started in 1992, these are now firmly established. The aim is to have GSM networks available along "corridors" linking major cities. The introduction of GSM has occurred at different rates throughout the various participating countries.

Phase 2 GSM Technical Specifications Frozen (1993)

Several major changes have been made to the GSM technical specifications since phase 1 was frozen in 1990. These changes include rewriting a number of specifications to remove ambiguities and faults. Many specifications have also been extended to detail new services and features.

The GSM Recommendations have now passed through the appropriate ETSI procedures and may now be referred to as "ETSI Technical Specifications". These procedures involve public enquiries and voting and the process takes several months.

GSM Coverage

GSM is widely used throughout the world, both GSM900/DCS1800.

GSM History

Date	Task Completion
1991	DCS1800 phase 1 recommendation frozen. GSM committee takes on next generation radio communication systems (UMTS).
1992	The GSM committee is renamed "Special Mobile Group" GSM System is renamed "Global System for Mobile Communications".
1992	GSM is launched for commercial operations.
1993	The phase 2 GSM technical specifications are frozen. World's first personal communication network (DCS1800) launched in UK in September.
1994	GSM commercial operations coverage world-wide exceeded GSM committee expectations (Russia, China, India, Middle East, Far East).
1995	DCS1800 commercial operations launched in Thailand, Qatar and United Kingdom. GSM System declared as the 'Gateway' for Iridium Satellite System.
1996	Introduction of microcellular techniques in GSM900/DCS1800 networks.

SMG Subsidiary Bodies

Overview

The SMG committee specifies all aspects of GSM. There are seven main sub-committees which meet several times per year to discuss and update the technical specifications that relate to their areas of concern. Each committee is responsible for a number of specifications.

The permanent nucleus is responsible for the co-ordination and release of the specifications. This group is now referred to as ETSI Project Team #12 (PT12).

The Technical Specifications

The scope of the technical specifications, and the committees that are responsible for them, are shown in the tables opposite.

GSM Committees

Committee Name	Committee Responsibility	Technical Specifications
SMG1	Definition of Services	01 ,02
SMG2	Specification of Radio Transmission	03, 05, 06
SMG3	Network Architecture, Signalling Protocols, Open Interfaces	03, 04, 08, 09
SMG4	Data Services	07
SMG5	UMTS	–
SMG6	Operation and Maintenance	12
11 Series	Test Specification	11

GSM History & Organisation

The GSM Memorandum of Understanding (MoU)

The technical specifications make up only part of the definition for GSM. Since so many countries are working together on this one system, commercial and operational aspects must also be taken into account.

A Memorandum of Understanding was put together which covered a number of items not covered by the technical specifications, these are listed below:

Timescales.

- Procurement.
- Routing plans.
- System deployment.
- Tariff principles.
- Concerted service introduction.
- Roaming agreements.

This memorandum was first signed in 1987 by operators and regulatory bodies in the participating countries. The MoU was updated in 1991.

Australia was the first non-European country to sign the the MoU many others have also signed since then.

GSM Technical Specifications

Specification Series Number	Specification Coverage
00	Preamble
01	General
02	Service aspects
03	Network aspects
04	MS–BS interface and protocols
05	Physical layer in the radio path
06	Audio aspects
07	Terminal adaptors for Mobile Stations
08	BTS/BSC and BSC/MSC interfaces
09	Network interworking
10	Service interworking
11	Equipment specification and type approval specification
12	Network management (including O&M)

GSM Coverage

GSM has been widely accepted throughout the world.

International roaming is available between many of the networks, and more agreements are added constantly as new networks go live.

A list of GSM networks is given opposite.

GSM Coverage

Andorra		Macao
Australia		Malaysia
Austria		Malta
Bahrain		Monaco
Belgium		Morocco
China		Namibia
Cyprus		New Zealand
Denmark		Nigeria
Egypt		Norway
Estonia		Oman
Finland		Pakistan
France		Philippines
Gibraltar		Portugal
Germany		Qatar
Great Britain		Rumania
Greece		Russia
Holland		Saudi Arabia
Hong Kong		Singapore
Hungary		Slovenia
Iceland		South Africa
India		Spain
Indonesia		Sri Lanka
Iran		Sweden
Ireland		Switzerland
Israel		Syria
Italy		Taiwan
Kuwait		Thailand
Latvia		Turkey
Lebanon		UAE
Liechtenstein		Uganda
Luxembourg		Vietnam



Appendix 2 (Call & Handover Sequences)

GSM Basic Call Sequence

The diagram opposite reminds us of the basic components and processes involved in setting up a call between a GSM MS and an ordinary “land” telephone.

- In the MS to Land direction

The BTS receives a data message from the MS which it passes it to the BSC. The BSC relays the message to the MSC via C7 signalling links, and the MSC then sets up the call to the land subscriber via the PSTN. The MSC connects the PSTN to the GSM network, and allocates a terrestrial circuit to the BSS serving the MS’s location. The BSC of that BSS sets up the air interface channel to the MS and then connects that channel to the allocated terrestrial circuit, completing the connection between the two subscribers.

- In the Land to MS direction

The MSC receives its initial data message from the PSTN (via C7) and then establishes the location of the MS by referencing the HLR. It then knows which other MSC to contact to establish the call and that MSC then sets up the call via the BSS serving the MS’s location.

The actual processes are, of course, considerably more complex than described above. Also, there are many different GSM call sequence and handover scenarios – enough to form the subject of their own training programme! In this course we consider in detail just the MS to Land and Land to MS call sequences and the intra-MSC (inter-BSS) handover sequence. This will give you a good appreciation of the messaging that occurs in the GSM system, and how the PLMN interacts with the PSTN.

GSM Basic Call Sequence

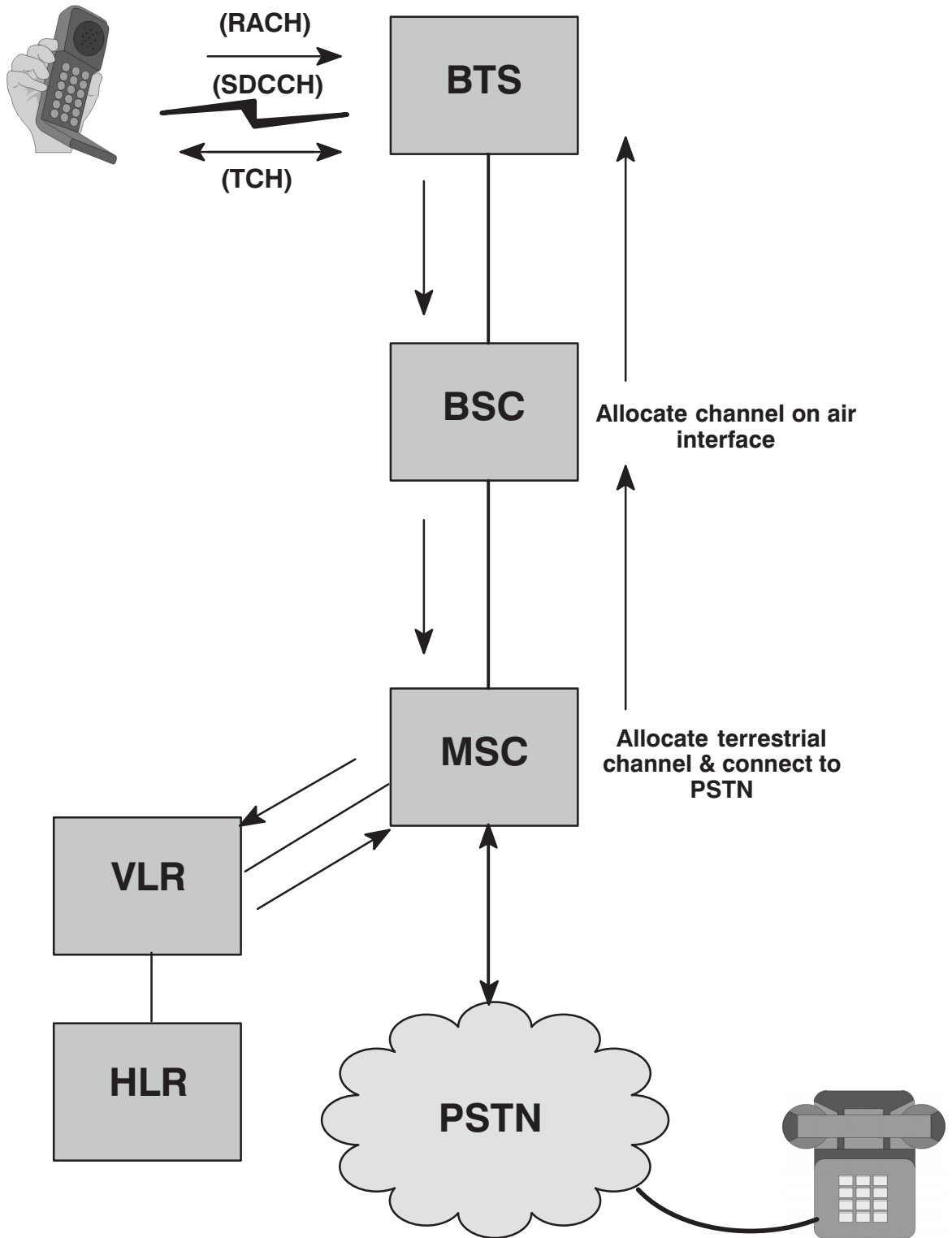

Mobile to Land Sequence

- 1** → The subscriber pressing the “send” key initiates a “Channel Request” message from the MS to the BSS. This is followed by the assignment of a dedicated control channel by the BSS and the establishment of the signalling link between the MS and BSS (“SABM” – Set Asynchronous Balanced Mode).
- 2** → The message “Request for Service” is passed to the MSC which relays it to the VLR. The VLR will carry out the authentication process if the MS has been previously registered on this VLR – if not, the VLR will have to obtain authentication parameters from HLR. The diagram assumes the MS was previously registered on this VLR.
- 3** → Subscriber authentication (optional) takes place using authentication messages and encryption algorithms and, if successful the Call setup can continue. If ciphering is to be used this is initiated at this time as the setup message contains sensitive information.
- 4** → The message “Set-Up” is sent by the MS to the MSC accompanied by the call information (type of call, and number being called etc.). The message is forwarded from the MSC to the VLR.
- 5** → The MSC may initiate the MS IMEI check (*is the MS stolen? etc*). Note that this check may occur later in the message sequence.
- 6** → In response to the message “Set-Up” (sent at step 4), the VLR sends the message “Complete Call” to the MSC, which notifies the MS with “Call Proceeding”.
- 7** → The MSC then assigns a traffic channel to the BSS (“Assignment Command”), which in turn assigns an air interface traffic channel. The MS responds to the BSS (which responds in turn to the MSC) with “Assignment Complete”.
- 8** → An “Initial and Final Address Message (IFAM)” is sent to the PSTN. Ring tone is applied at the MS in response to “Alerting”, which the MSC sends to the MS when the PSTN responds with an “Address Complete Message (ACM)”.
- 9** → When answered (“Answer (ANS)” from the PSTN), the message “Connect” is forwarded to the MS by the MSC, stopping the MS ring tone. The MSC then connects the GSM traffic channel to the PSTN circuit, thus completing the end to end traffic connection.
- 10** → Conversation takes place for the duration of the call.

Mobile to Land Sequence

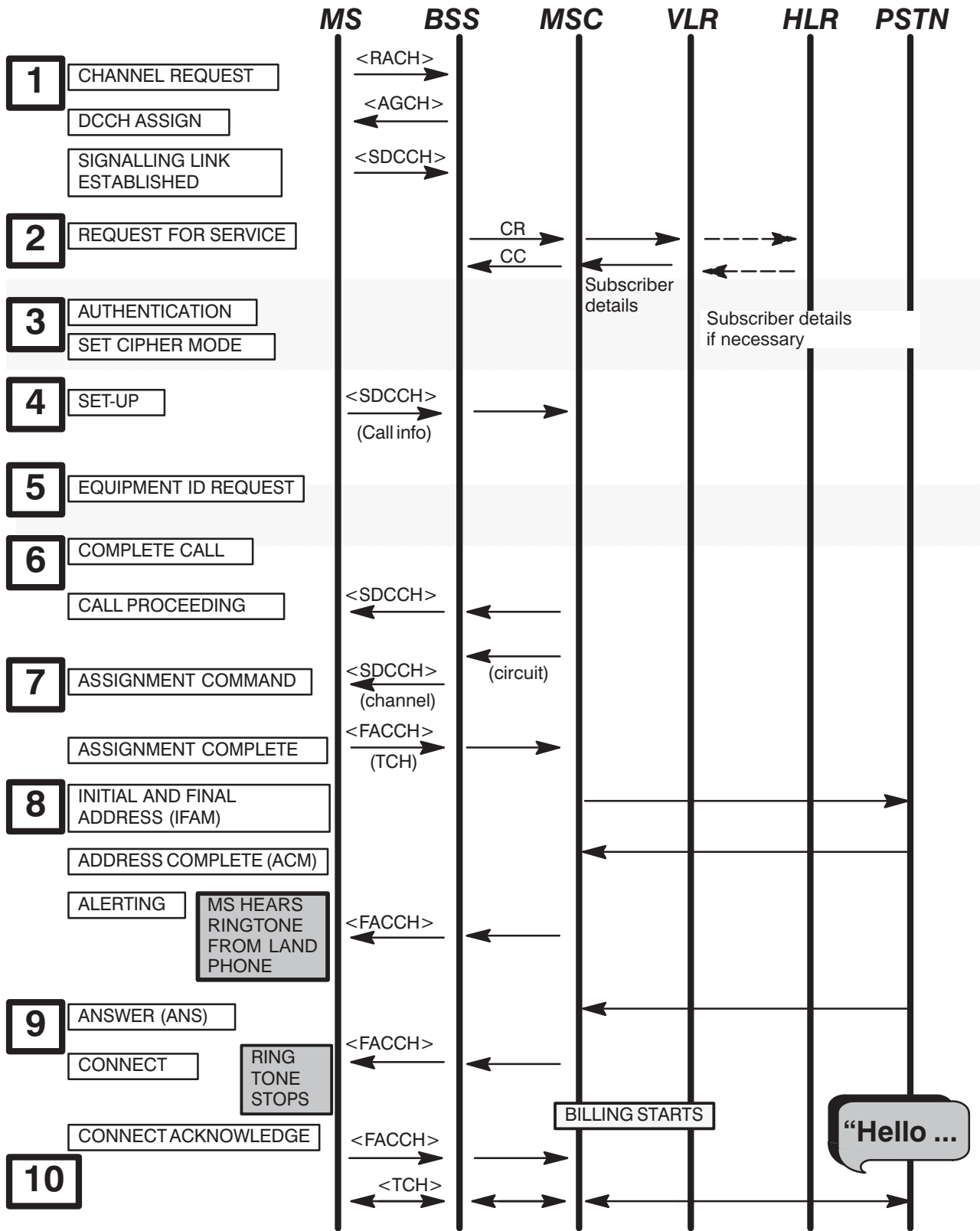

Land to Mobile Sequence

- 1** → A C7 “Initial and Final Address Message (IFAM)” arrives at a “gateway” MSC (GMSC). The MS to be called is identified by its MSISDN.
- 2** → Using the message “Send Routing Info”, still tagged by the MS’s MSISDN, the GMSC requests routing information from the HLR. This forwards the message, now retagged with the MS’s IMSI, to the VLR serving the LAI in which the MS is currently located. The requested information will enable the GMSC to identify the MSC to which the IFAM must be directed.
- 3** → The VLR responds with the message “Routing Information Ack.”, now tagged with an MSRN which is either newly drawn from its pool of MSRNs or already associated with the MS being called. The GMSC now sends an **IFAM** to the MSC serving the MSs location, tagged with the MSRN.
- 4** → The ‘visitor’ MSC then requests call set-up information from the VLR (“Send Info for I/C Call Setup”).
- 5** → The VLR response is the “Page” message back to the MSC, containing the required information. The MSC then sends “Paging Request” to the MS via the appropriate BSS.
- 6** → The MS responds and requests a dedicated control channel from the BSS (“Channel Request”) and the air interface signalling link is established. Once established, this dedicated control channel carries “Paging Response” to the BSS which relays it to the VLR, via the MSC.

Land to Mobile Sequence

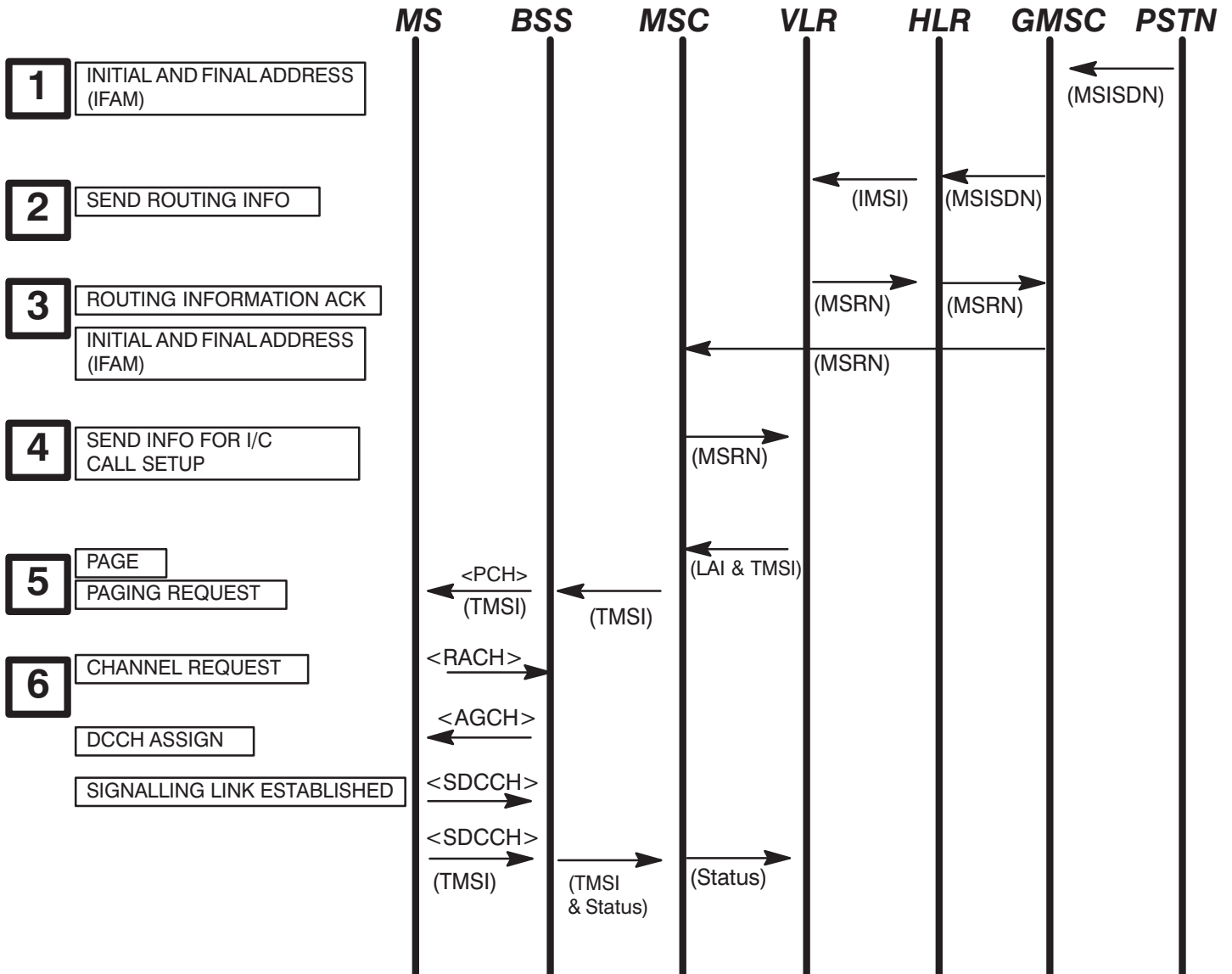

- 7** → The MS subscriber is authenticated and cipher mode is set (opt). The “Complete Call” message is then sent to the MSC from the VLR. This is relayed to the MS via the BSS as the message “Setup”.
- 8** → The MS sends the message “Call Confirmation” to the MSC. This indicates that the MS is capable of receiving a call and the MSC sends an “Address Complete Message (ACM)” to the GMSC which relays it to the PSTN. The land subscriber will now hear ring tone.
- 9** → The MSC then assigns a traffic channel to the BSS (“Assignment Command”), which in turn assigns an air-interface traffic channel. The MS responds to the BSS (which responds in turn to the MSC) with “Assignment Complete”. The MS now rings, sending the message “Alert” to the MSC as confirmation.
- 10** → When the GSM subscriber answers, the MS sends the message “Connect” to the MSC. The MSC acknowledges this (“Connect Ack”) and sends “Answer (ANS)” to the GMSC and PSTN. The land subscriber’s ring tone stops and the GMSC and MSC connect the GSM traffic channel and the PSTN circuit together.
- 11** → Conversation takes place for the duration of the call.

Land to Mobile Sequence

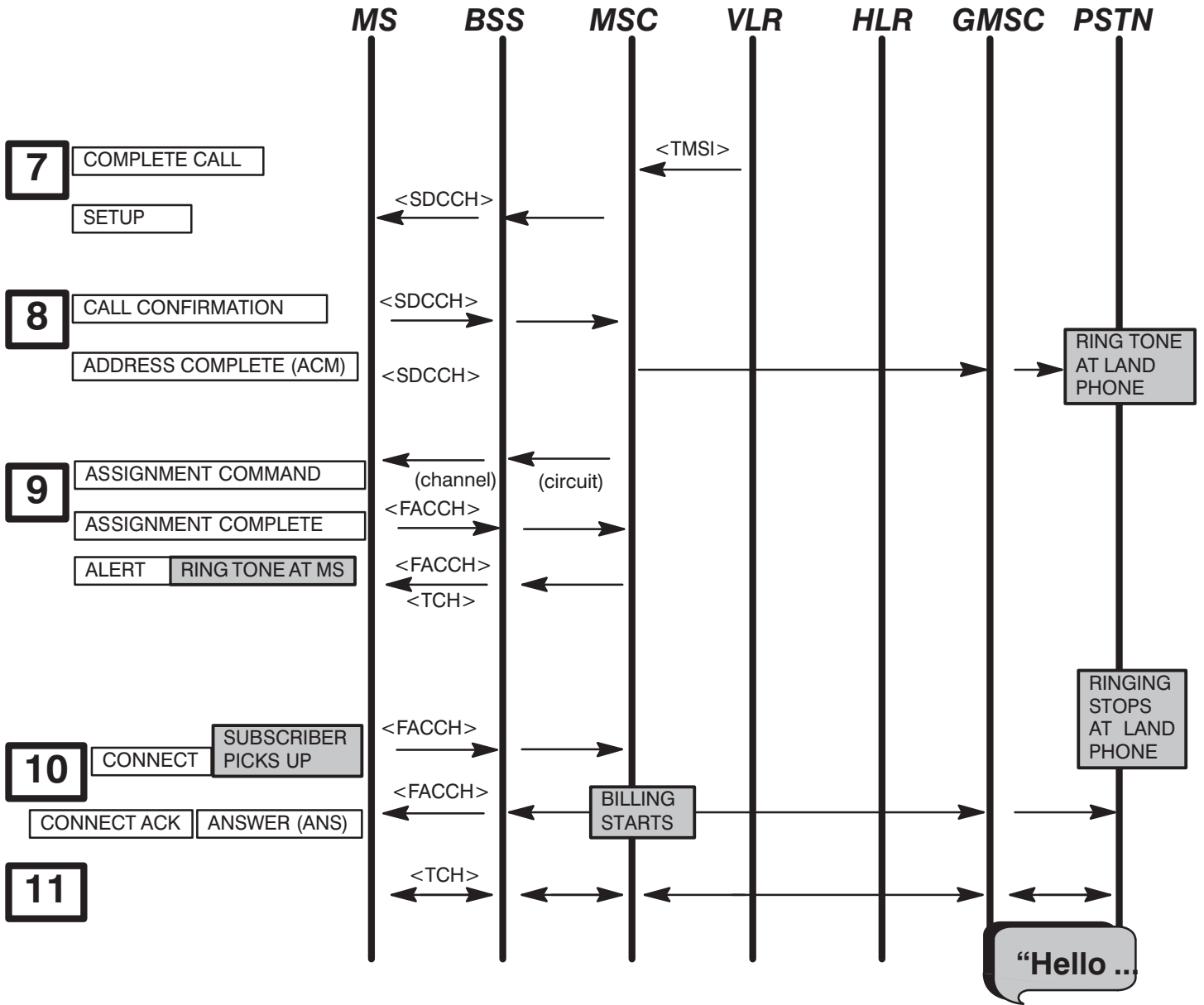

MS Initiated Call Clearing Sequence

- 1** → The MS initiates the clearing of the call by sending the “Disconnect” message to the MSC. The MSC will then send a “Release” message to the PSTN which will then start to release the fixed network circuits associated with the call . The MSC will also send a “Release” message to the MS to indicate that it may clear down the call.
- 2** → When the MS receives the message, it will release the call and respond with the “Release Complete” message. The PSTN will also respond with a “Release Complete” message.
- 3** → The MSC now initiates the freeing up of the air interface radio resources and the A interface terrestrial resources related to the call. The MSC will send the “Clear Command” to the BSS. The BSS in turn will send a “Channel Release” on to the MS this will start the release of the radio resources used for that call. The BSS will then respond to the MSC with the “Clear Complete” message indicating that is has released the radio and terrestrial resources.
- 4** → The BSS will complete the release of the radio resources by sending the “DISC” message to the MS. The MS will respond with an “Unnumbered Acknowledgement (UA)” message.
- 5** → The MSC will now initiate the release of the signalling connection related to the call. The MSC will send the “Released” message to the BSS, which will respond with the “Release Complete” message.
- 6** → The call is now cleared and all resources are available for another subscriber.

Mobile Initiated Call Clearing Sequence

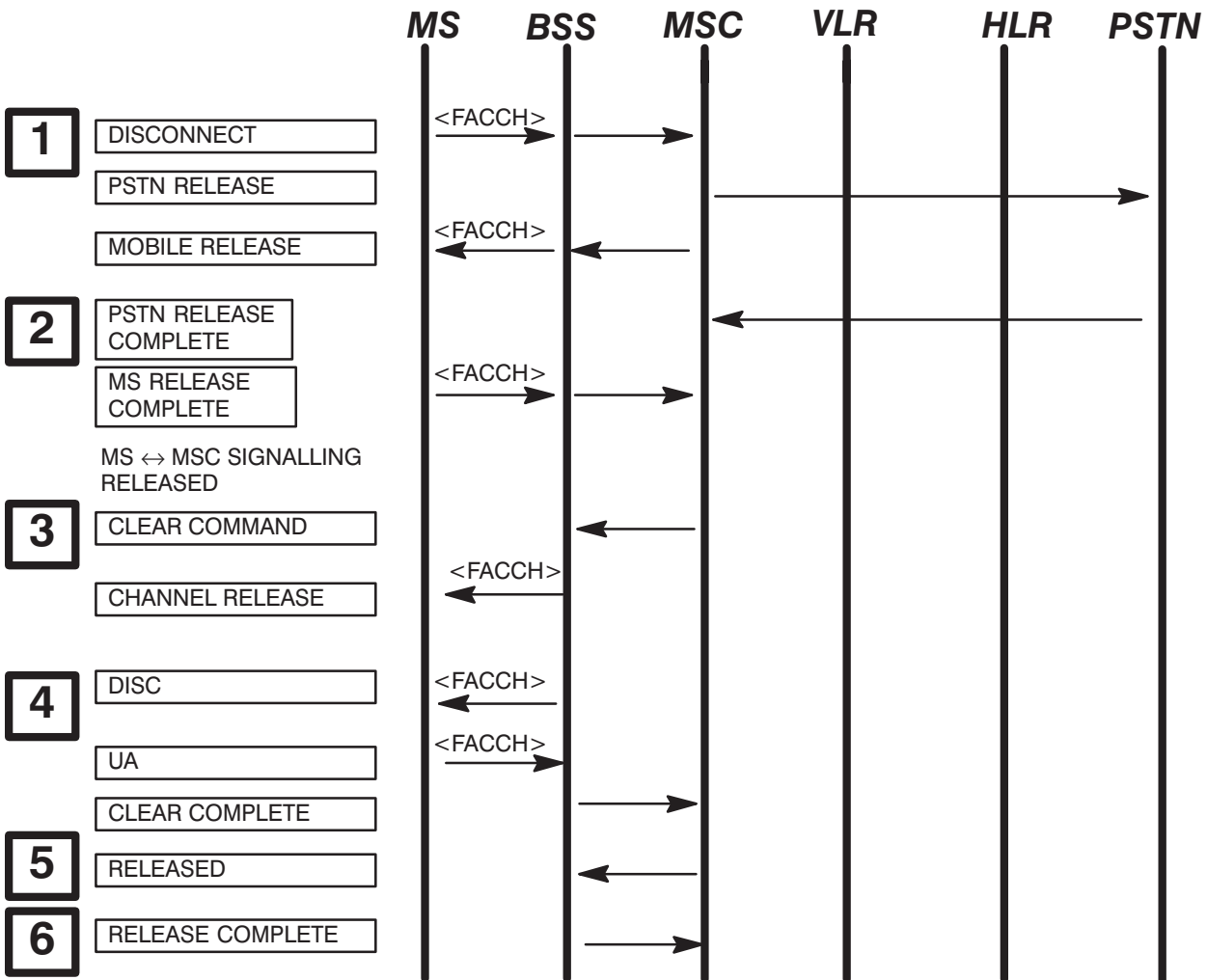

Inter-BSS Handover Sequence

- 1 → The MS is in the conversation state and is continuously compiling measurements both of the current transmission and the broadcast control channels of up to thirty two surrounding cells. The measurements from the six best cells are reported back to the BSS, every 480 ms.
- 2 → When a handover is required, due to low Receive Signal Strength Indication (RSSI) or poor signal quality the existing "originating" BSS (oBSS) notifies the MSC ("Handover Required").
- 3 → The target or 'new' BSS (nBSS) is alerted with the message "Handover Request" tagged with the TMSI.
- 4 → The new BSS allocates a Handover Reference Number which it uses to determine whether the correct MS gains access to the air interface channel which it allocates, and acknowledges the MSC's request with "Handover Request Ack". This is tagged with the HO Reference number. The nBSS assigns a traffic channel.
- 5 → The MSC, via the oBSS orders the MS to change to the new channel with the message "Handover Command" on FACCH.
- 6 → There is an information interchange between nBSS and MS. This uses the FACCH channel but an access burst is used. The messages and information carried depend upon the type of handover being performed.
- 7 → Once all necessary information has been transferred the message "Handover Complete" is sent to the MSC.
- 8 → The MSC now sends a "Clear Command" to the oBSS, this frees the radio resources for another MS. The channel is not cleared until this point in case the new BSS can not accommodate the MS being handed over.
- 9 → The MS, still in the conversation mode, then continues to prepare periodic measurement reports and sends them to the new BSS.

Acronyms:

TMSI	Temporary Mobile Subscriber Identity
MSRN	Mobile Station Roaming Number
IMSI	International Mobile Subscriber Identity
MSISDN	Mobile Station ISDN Number
LAI	Location Area Identity
SACCH	Slow Associated Control Channel
FACCH	Fast Associated Control Channel

Inter-BSS Handover Sequence

... and so I said to ...

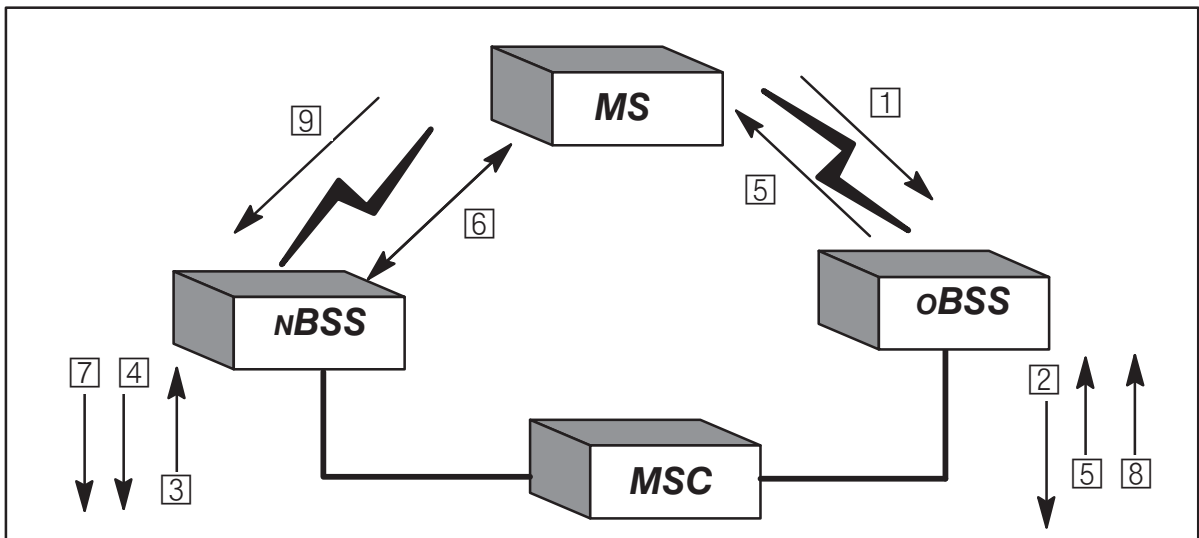
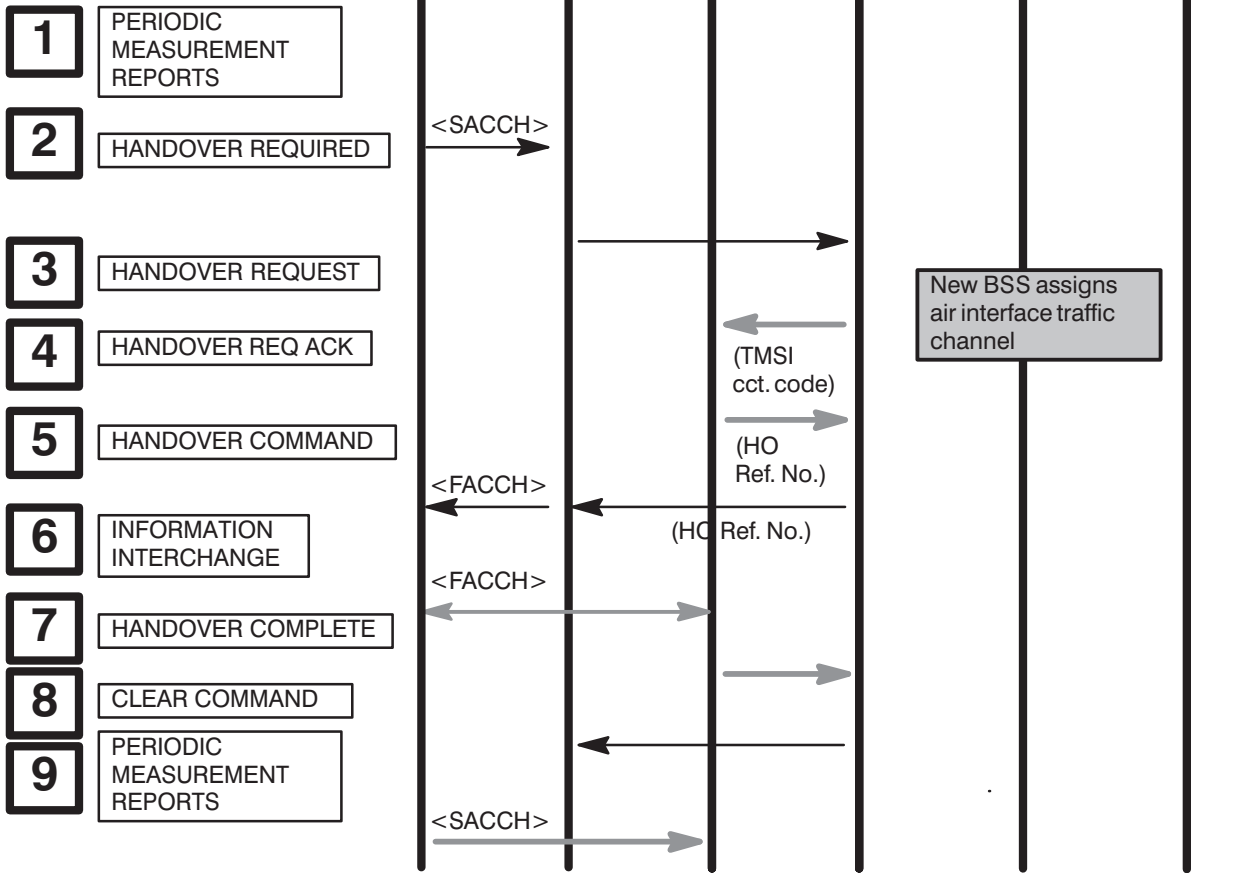

Location Update Sequence

- 1** → A location update is initiated by the MS when it detects that it has entered a new location area. The location area is transmitted on the BCCH as the LAI. The MS will be assigned an SDCCH by the BSS, the location updating procedure will be carried out using this channel.
- 2** → Once the SDCCH has been assigned, the MS transmits a “Location Update Request” message. This message is received by the MSC which then sends the new LAI and the current MS TMSI number to the VLR. The information will also be sent to the HLR if the MS has not previously been updated on the network.
- 3** → Authentication and ciphering may now take place if required.
The VLR will now assign a new TMSI for the MS, this number will be sent to the MSC using the “Forward New TMSI” message. The VLR will now initiate the “Location Update Accept” message which will transmit the new TMSI and LAI to the MS.
- 4** →
- 5** → Once the MS has stored both the TMSI and the LAI on its SIM card it will send the “TMSI Relocate Complete” message to the MSC. The MSC will then send the “TMSI ACK” message to the VLR to confirm that the location update has been completed.
- 6** → The SDCCH will then be released by the MS.

Location Update Sequence

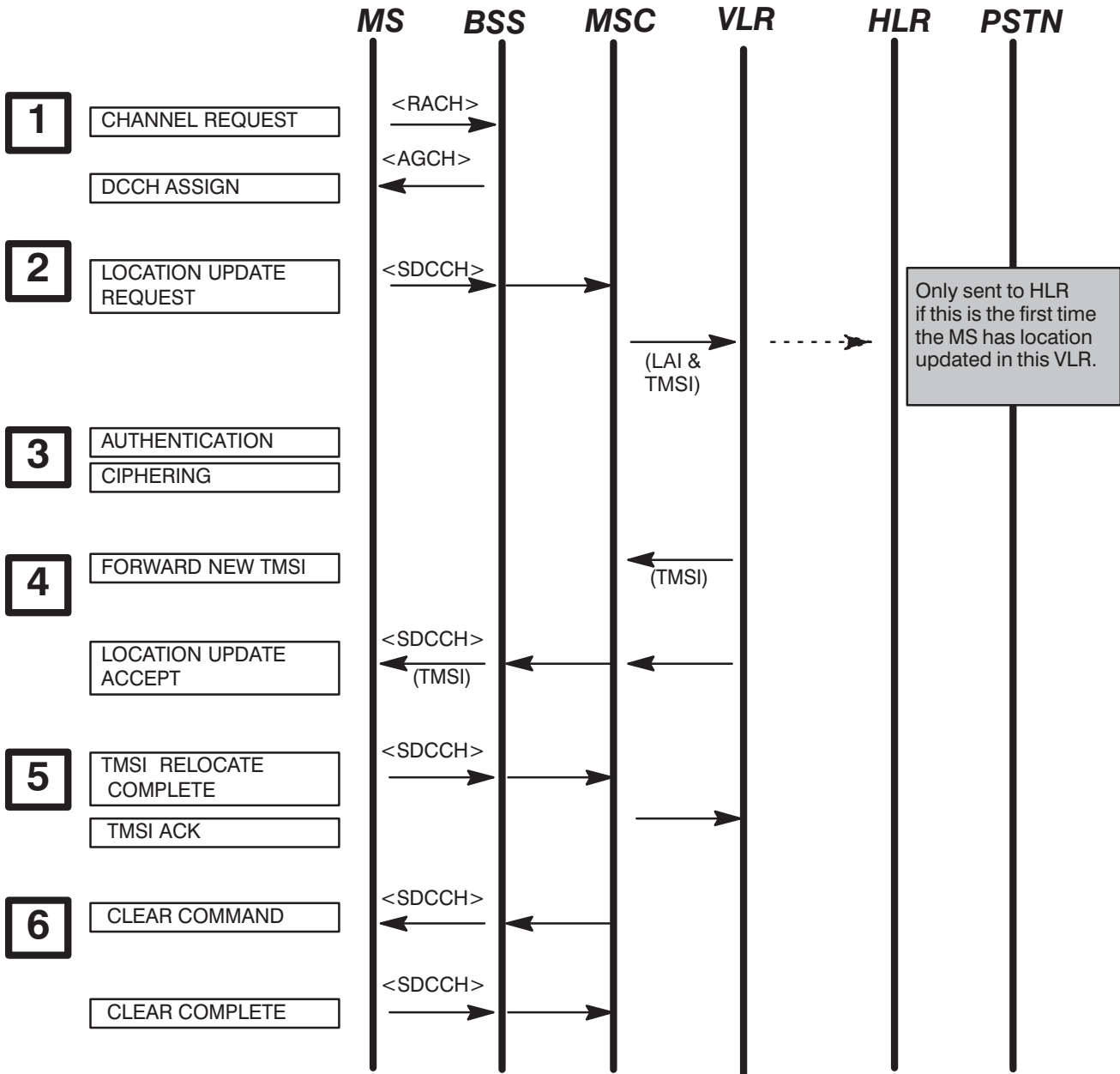

Authentication and Ciphering

- Authentication may be executed during call setup, location updating and supplementary services. The HLR/AUC produce the authentication parameters (RAND/SRES/Kc) these are called “triples”. Triples are sent to the VLR where the MS is registered. These triples are sent in groups of six and stored in the VLR. This ensures that the VLR can carry out the authentication and that it will not have to contact the HLR.
- 1** →
 - 2** → The VLR initiates the authentication by sending a message “Authenticate” to the MSC. The MSC will repackage this message and send it on to the MS. The message is an “Authentication Request” and contains the random number RAND.
 - 3** → The MS responds with the “Authentication Response” message, this contains the signed response (SRES).
 - 4** → If authentication is successful, the VLR will request that the MSC start ciphering procedures, using the “Start Ciphering” message. This message contains information indicating whether ciphering is required.
 - 5** → The MSC will start ciphering procedures by sending the “Cipher Mode Command” message to the BSS. This message contains the encryption information required by the BSS. The BSS will respond with the “Cipher Mode Complete” message.

Note:

If the authentication fails, the HLR will be notified and an “Authentication Reject” message will be send to the MS.

Authentication and Ciphering

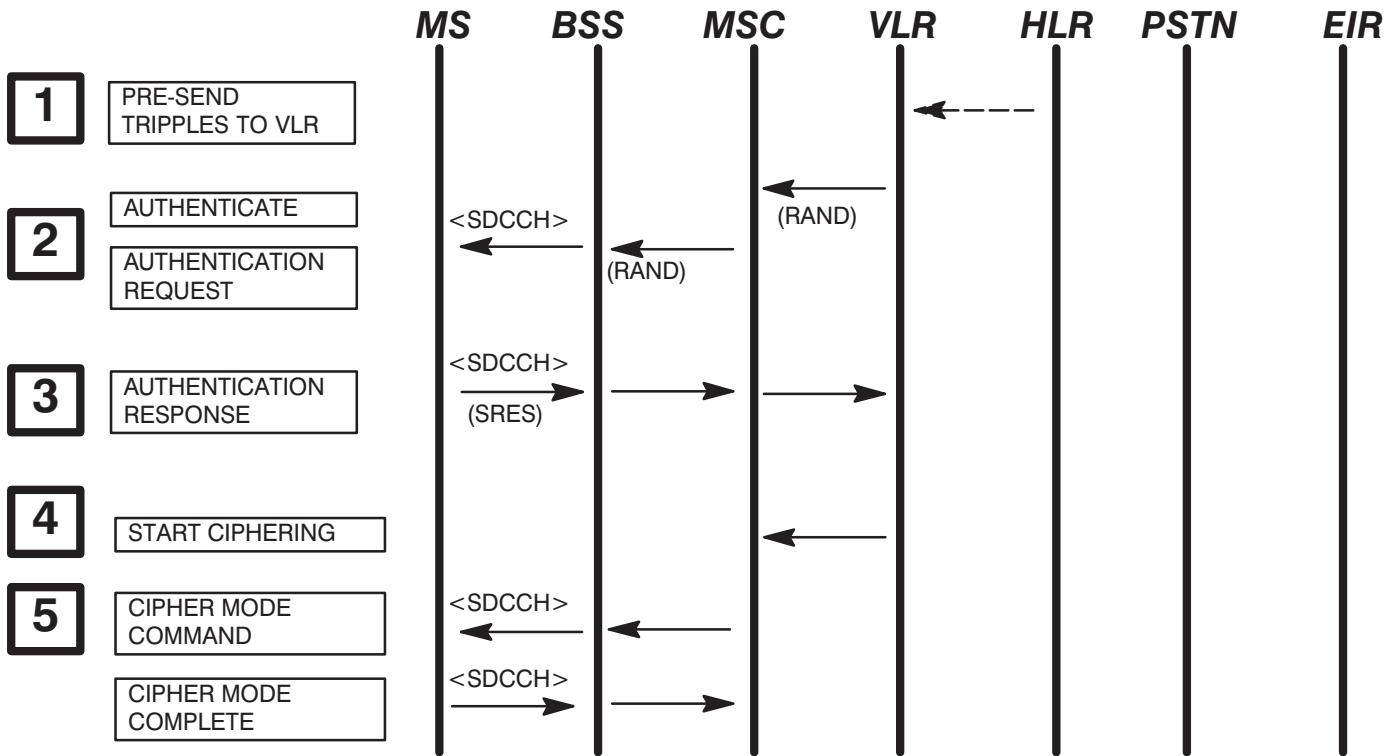

Equipment Identification

- 1** → Equipment Identification will be initiated by the MSC sending the “Equipment ID Request” message to the MS. This will be carried out less frequently than authentication. The frequency of the checks will be at the discretion of the network provider. Equipment Identification will be carried out during a Location Update or a Call Setup.
- 2** → The MS will respond to the message by sending the “ID Response” message. This message contains the equipment’s IMEI number.
- 3** → The MSC will send the IMEI number on to the EIR using the “Check IMEI” message. The EIR will respond with the “Check IMEI Response”. Checking of the IMEI at the EIR may occur after the TCH has been allocated to the MS.

Equipment Identification

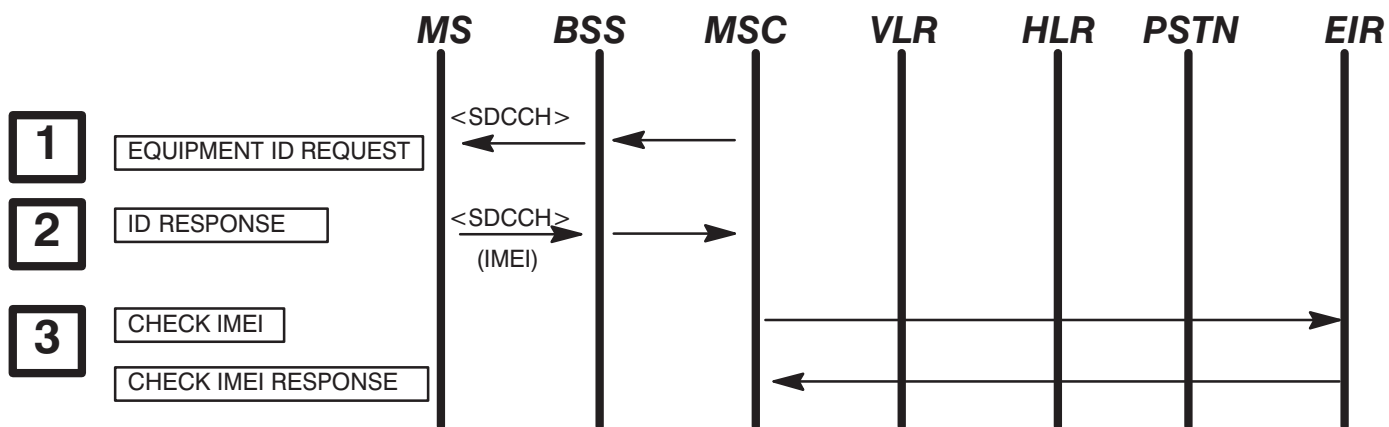

Note:

IMEI check may be deferred until after traffic channel has been established!



Glossary of technical terms and abbreviations

Numbers

#	Number.
2 Mbit/s link	As used in this manual set, the term applies to the European 4-wire 2.048 Mbit/s digital line or link which can carry 30 A-law PCM channels or 120 16 kbit/s GSM channels.
4GL	4 th Generation Language.

A

A interface	Interface between MSC and BSS.
A3	Authentication algorithm that produces SRES, using RAND and Ki.
A38	A single algorithm performing the function of A3 and A8.
A5	Stream cipher algorithm, residing on an MS, that produces ciphertext out of plaintext, using Kc.
A8	Ciphering key generating algorithm that produces Kc using RAND and Ki.
AB	Access Burst.
Abis interface	Interface between a remote BSC and BTS. Motorola offers a GSM standard and a unique Motorola A-bis interface. The Motorola interface reduces the amount of message traffic and thus the number of 2 Mbit/s lines required between BSC and BTS.
ABR	Answer Bid Ratio.
ac-dc PSM	AC-DC Power Supply module.
ac	Alternating Current.
AC	Access Class (C0 to C15).
AC	Application Context.
ACC	Automatic Congestion Control.
ACCH	Associated Control CHannel.
ACK, Ack	ACKnowledgement.
ACM	Accumulated Call meter.
ACM	Address Complete Message.
ACPIM	AC Power Interface Module. Used in M-Cell6 indoor ac BTS equipment.
AC PSM	AC Power Supply Module. Used in M-Cell6 BTS equipment.
ACSE	Associated Control Service Element.
ACU	Antenna Combining Unit.
A/D	Analogue to Digital (converter).
ADC	ADministration Centre.
ADC	Analogue to Digital Converter.
ADCCP	ADvanced Communications Control Protocol.
ADM	ADMinistration processor.
ADMIN	ADMINistration.
ADN	Abbreviated Dialling Number.

ADPCM	Adaptive Differential Pulse Code Modulation.
AE	Application Entity.
AEC	Acoustic Echo Control.
AEF	Additional Elementary Functions.
AET	Active Events Table. Alarms and events are sent to the Events Log in the GUI. Different operators will have different subscription lists. All alarms and events are sent to the AET before they are re-routed to different subscription lists.
AFC	Automatic Frequency Control.
AFN	Absolute Frame Number.
AGC	Automatic Gain Control.
AGCH	Access Grant CHannel. A GSM common control channel used to assign MS to a SDCCH or a TCH.
Ai	Action indicator.
AI	Artificial Intelligence.
AIB	Alarm Interface Board.
AIO	A class of processor.
Air interface	The radio link between the BTS and the MS.
AM	Amplitude Modulation.
AMA	Automatic Message Accounting (processor).
AM/MP	Cell broadcast mobile terminated message. A message broadcast to all MSs in a cell.
AoC	Advice of Change.
AoCC	Advice of Change Charging supplementary service.
AoCI	Advice of Change Information supplementary service.
AOC	Automatic Output Control.
AP	Application Process.
ARFCN	Absolute Radio Frequency Channel Number. An integer which defines the absolute RF channel number.
ARQ	Automatic ReQuest for retransmission.
ARP	Address Resolution Protocol.
ASCE	Association Control Service Element. An ASE which provides an AP with the means to establish and control an association with an AP in a remote NE. Maps directly onto the Presentation layer (OMC).
ASE	Application Service Element (OMC)
ASE	Application Specific Entity (TCAP).
ASN.1	Abstract Syntax Notation One.
ASP	Alarm and Status Panel.
ASR	Answer Seizure Ratio.
ATB	All Trunks Busy.
ATI	Antenna Transceiver Interface.
ATT (flag)	ATTach.

ATTS	Automatic Trunk Testing Subsystem.
AU	Access Unit.
AuC	Authentication Centre. A GSM network entity which provides the functionality for verifying the identity of an MS when requested by the system. Often a part of the HLR.
AUT(H)	AUThentication.
AUTO	AUTOMATIC mode.

B

B Interface	Interface between MSC and VLR.
BA	BCCH Allocation. The radio frequency channels allocated in a cell for BCCH transmission.
BAIC	Barring of All Incoming Calls supplementary service.
BAOC	Barring of All Outgoing Calls supplementary service.
BBBX	Battery Backup Board.
BBH	Base Band Hopping.
BCC	BTS Colour Code.
BCCH	Broadcast Control CHannel. A GSM control channel used to broadcast general information about a BTS site on a per cell or sector basis.
BCD	Binary Coded Decimal.
BCF	Base station Control Function. The GSM term for the digital control circuitry which controls the BTS. In Motorola cell sites this is a normally a BCU which includes DRI modules and is located in the BTS cabinet.
BCIE	Bearer Capability Information Element.
BCU	Base station Control Unit. A functional entity of the BSS which provides the base control function at a BTS site. The term no longer applies to a type of shelf (see <i>BSC</i> and <i>BSU</i>).
BCUP	Base Controller Unit Power.
BER	Bit Error Rate. A measure of signal quality in the GSM system.
BES	Business Exchange Services.
BFI	Bad Frame Indication.
BHCA	Busy Hour Call Attempt.
BI	all Barring of All Incoming call supplementary service.
BIB	Balanced-line Interconnect Board. Provides interface to 12 balanced (6-pair) 120 ohm (37-pin D-type connector) lines for 2 Mbit/s circuits (See also <i>T43</i>).
BIC-Roam	Barring of All Incoming Calls when Roaming outside the Home PLMN Country supplementary service.
BIM	Balanced-line Interconnect Module.
Bin	An area in a data array used to store information.
BL	BootLoad. Also known as download. For example, databases and software can be downloaded to the NEs from the BSS.

BLLNG	BiLLiNG.
bit/s	Bits per second (bps).
Bm	Full rate traffic channel.
BN	Bit Number. Number which identifies the position of a particular bit period within a timeslot.
BPF	Bandpass Filter.
BPSM	μ BCU Power Supply Module.
BS	Basic Service (group).
BS	Bearer Service. A type of telecommunication service that provides the capability for the transmission of signals between user-network interfaces. The PLMN connection type used to support a bearer service may be identical to that used to support other types of telecommunication service.
BSC	Base Station Controller. A network component in the GSM PLMN which has the digital control function of controlling all BTSs. The BSC can be located within a single BTS cabinet (forming a BSS) but is more often located remotely and controls several BTSs (see <i>BCF</i> , <i>BCU</i> , and <i>BSU</i>).
BSG	Basic Service Group.
BSIC	Base Transceiver Station Identity Code. A block of code, consisting of the GSM PLMN colour code and a base station colour code. One Base Station can have several Base Station Colour Codes.
BSIC-NCELL	BSIC of an adjacent cell.
BSP	Base Site control Processor (at BSC).
BSN	Backward Sequence Number.
BSS	Base Station System. The system of base station equipment (Transceivers, controllers and so on) which is viewed by the MSC through a single interface as defined by the GSM 08 series of recommendations, as being the entity responsible for communicating with MSs in a certain area. The radio equipment of a BSS may cover one or more cells. A BSS may consist of one or more base stations. If an internal interface is implemented according to the GSM 08.5x series of recommendations, then the BSS consists of one BSC and several BTSs.
BSSAP	BSS Application Part (of Signalling System No. 7) (DTAP + BSSMAP).
BSSC	Base Station System Control cabinet. The cabinet which houses one or two BSU shelves at a BSC or one or two RXU shelves at a remote transcoder.
BSSMAP	Base Station System Management Application Part (6-8).
BSSOMAP	BSS Operation and Maintenance Application Part (of Signalling System No. 7).
BSU	Base Station Unit shelf. The shelf which houses the digital control modules for the BTS (<i>p/o BTS cabinet</i>) or BSC (<i>p/o BSSC cabinet</i>).
BT	British Telecom.
BT	Bus Terminator.

BTC	Bus Terminator Card.
BTF	Base Transceiver Function.
BTP	Base Transceiver Processor (at BTS). One of the six basic task groups within the GPROC.
BTS	Base Transceiver Station. A network component in the GSM PLMN which serves one cell, and is controlled by a BSC. The BTS contains one or more Transceivers (TRXs).
Burst	A period of modulated carrier less than one timeslot. The physical content of a timeslot.

C

C	Conditional.
C Interface	Interface between MSC and HLR/AUC.
C7	ITU-TSS Signalling System 7 (sometimes referred to as S7 or SS#7).
CA	Cell Allocation. The radio frequency channels allocated to a particular cell.
CA	Central Authority.
CAB	Cabinet.
CADM	Country ADMinistration. The Motorola procedure used within DataGen to create new country and network files in the DataGen database.
CAI	Charge Advice Information.
CAT	Cell Analysis Tool.
CB	Cell Broadcast.
CB	Circuit Breaker.
CBC	Cell Broadcast Centre.
CBCH	Cell Broadcast CHannel.
CBF	Combining Bandpass Filter.
CBL	Cell Broadcast Link.
CBM	Circuit Breaker Module.
CBMI	Cell Broadcast Message Identifier.
CBSMS	Cell Broadcast Short Message Service.
CBUS	Clock Bus.
CC	Connection Confirm (Part of SCCP network connectivity).
CC	Country Code.
CC	Call Control.
CCB	Cavity Combining Block, a three way RF combiner. There are two types of CCB, CCB (Output) and CCB (Extension). These, with up to two CCB Control cards, may comprise the TATI. The second card may be used for redundancy.
CCBS	Completion of Calls to Busy Subscriber supplementary service.

CCCH	Common Control CHannels. A class of GSM control channels used to control paging and grant access. Includes AGCH, PCH, and RACH.
CCCH_GROUP	Group of MSs in idle mode.
CCD	Common Channel Distributor.
CCDSP	Channel Coding Digital Signal Processor.
CCF	Conditional Call Forwarding.
CCH	Control CHannel. Control channels are channels which carry system management messages.
CCH	Council for Communications Harmonization (referred to in GSM Recommendations).
CCIT	Comité Consultatif International Télégraphique et Téléphonique. This term has been superceded by ITU-TSS (International Telecommunications Union – Telecommunications Sector).
CCM	Current Call Meter.
CCP	Capability/Configuration Parameter.
CCPE	Control Channel Protocol Entity.
CCS	Hundred call-seconds. The unit in which amounts of telephone traffic are measured. A single call lasting one hundred seconds is one CCS. See also <i>erlang</i> .
Cct	Circuit.
CDB	Control Driver Board.
CDE	Common Desktop Environment. Part of the SUN software (crontab – cron job file).
CDR	Call Detail Records.
CDUR	Chargeable DURation.
CEB	Control Equalizer Board (BTS).
CED	Called station identifier.
CEIR	Central Equipment Identity Register.
Cell	By GSM definition, a cell is an RF coverage area. At an omni-site, cell is synonymous with site; at a sectored site, cell is synonymous with sector. This differs from analogue systems where cell is taken to mean the same thing as site. (See below).

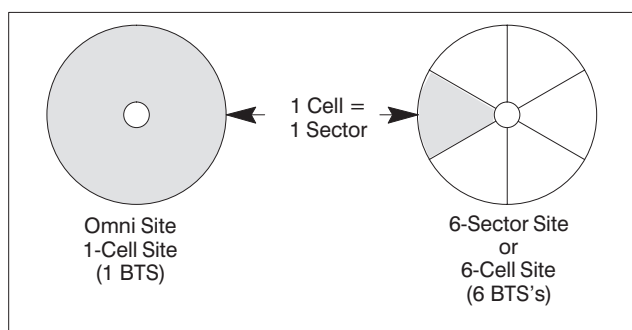

CEND	End of charge point.
CEPT	Conférence des administrations Européennes des Postes et Telecommunications.
CERM	Circuit Error Rate Monitor.
CF	Conversion Facility.
CF	all Call Forwarding services.
CFB	Call Forwarding on mobile subscriber Busy supplementary service.
CFC	Conditional Call Forward.
CFNRc	Call Forwarding on mobile subscriber Not Reachable supplementary service.
CFNRy	Call Forwarding on No Reply supplementary service.
CFU	Call Forwarding Unconditional supplementary service.
Channel	A means of one-way transmission. A defined sequence of periods (for example, timeslots) in a TDMA system; a defined frequency band in an FDMA system; a defined sequence of periods and frequency bands in a frequency hopped system.
CIM	Coaxial Interconnect Module.
CHP	CHarging Point.
CHV	Card Holder Verification information.
CKSN	Ciphering Key Sequence Number.
CI	Cell Identity. A block of code which identifies a cell within a location area.
CI	CUG Index.
CIC	Circuit Identity Code.
CIR, C/I	Carrier to Interference Ratio.
Ciphertext	Unintelligible data produced through the use of encipherment.
CKSN	Ciphering Key Sequence Number.
CLI	Calling Line Identity.
CLIP	Calling Line Identification Presentation supplementary service.
CLIR	Calling Line Identification Restriction supplementary service.
CLK	Clock.
CLKX	Clock Extender half size board. The fibre optic link that distributes GCLK to boards in system (p/o BSS etc).
CLM	Connectionless Manager.
CLR	CLear.
CM	Configuration Management. An OMC application.
CM	Connection Management.
CMD	CoMmanD.
CMM	Channel Mode Modify.
CMIP	Common Management Information Protocol.

CMISE	Common Management Information Service Element. An ASE which provides a means to transfer management information via CMIP messages with another NE over an association established by ASCE using ROSE (OMC).
CMR	Cellular Manual Revision.
CNG	CalliNg tone.
COLI	COConnected Line Identity.
Collocated	Placed together; two or more items together in the same place.
Coincident Cell	A cell which has a co-located neighbour whose cell boundary follows the boundary of the said cell. The coincident cell has a different frequency type, but the same BSIC, as that of the neighbour cell.
COLP	COConnected Line Identification Presentation supplementary service.
COLR	COConnected Line Identification Restriction supplementary service.
CODEX	Manufacturer's name for a type of multiplexer and packet switch commonly installed at the Motorola OMC-R.
COM	Code Object Manager.
COM	COMplete.
COMB	Combiner.
CONNACK	CONNect ACKnowledgement.
COMM, Comms	COMMunications.
CommsLink	Communications Link. (2Mbit/s)
CONF	CONFerence circuit.
CONFIG	CONFIGuration Control Program.
CP	Call Processing.
CPU	Central Processing Unit.
C/R	Command/Response field bit.
CR	Carriage Return (RETURN).
CR	Connection Request (Part of SCCP network connectivity).
CRC	Cyclic Redundancy Check (3 bit).
CRE	Call RE-establishment procedure.
CREF	Connection REFused (Part of SCCP network connectivity).
CRM	Cell Resource Manager.
CRM-LS/HS	Cellular Radio Modem-Low Speed/High Speed. Low speed modem used to interwork 300 to 2400 bit/s data services under V.22bis, V.23, or V.21 standards. High speed modem used to interwork 1200 to 9600 bit/s data services under V.22bis, V.32, or V.29/V.27ter/V.21 standards.
CRT	Cathode Ray Tube (video display terminal).
CSFP	Code Storage Facility Processor (at BSC and BTS).
CSP	Central Statistics Process. The statistics process in the BSC.
CSPDN	Circuit Switched Public Data Network.

CT	Call Transfer supplementary service.
CT	Channel Tester.
CT	Channel Type.
CTP	Call Trace Product (Tool).
CTR	Common Technical Regulation.
CTS	Clear to Send. Method of flow control (RS232 Interface).
CTU	Compact Transceiver Unit (M-Cell <i>horizon</i> radio).
CUG	Closed User Group supplementary service.
Cumulative value	The total value for an entire statistical interval.
CW	Call Waiting supplementary service.

D

D Interface	Interface between VLR and HLR.
D/A	Digital to Analogue (converter).
DAB	Disribution Alarm Board.
DAC	Digital to Analogue Converter.
DACS	Digital Access Cross-connect System.
DAN	Digital ANnouncer (for recorded announcements on MSC).
DAS	Data Acquisition System.
DAT	Digital Audio Tape.
DataGen	Sysgen Builder System. A Motorola offline BSS binary object configuration tool.
dB	Decibel. A unit of power ratio measurement.
DB	DataBase.
DB	Dummy Burst (see <i>Dummy burst</i>).
DBA	DataBase Administration/Database Administrator.
DBMS	DataBase Management System.
dc	Direct Current.
DCB	Diversity Control Board (p/o DRCU).
DCCH	Dedicated Control CHannel. A class of GSM control channels used to set up calls and report measurements. Includes SDCCH, FACCH, and SACCH.
DCD	Data Carrier Detect signal.
DCE	Data Circuit terminating Equipment.
DCF	Data Communications Function.
DCF	Duplexed Combining bandpass Filter. (Used in <i>Horizonmacro</i>).
DCN	Data Communications Network. A DCN connects Network Elements with internal mediation functions or mediation devices to the Operations Systems.
DC PSM	DC Power Supply Module.

DCS1800	Digital Cellular System at 1800 MHz. A cellular phone network using digital techniques similar to those used in GSM 900, but operating on frequencies of 1710 – 1785 MHz and 1805 – 1880 MHz.
DDF	Dual-stage Duplexed combining Filter. (Used in <i>Horizonmacro</i>).
DDS	DataGen Directory Structure.
DDS	Data Drive Storage.
DDS	Direct Digital Synthesis.
DEQB	Diversity Equalizer Board.
DET	DETach.
DFE	Decision Feedback Equalizer.
DGT	Data Gathering Tool.
DHP	Digital Host Processor.
DIA	Drum Intercept Announcer.
DINO E1/HDSL	Line termination module.
DINO T1	Line termination module.
DISC	DISConnect.
Discon	Discontinuous.
DIQ	Diversity In phase and Quadrature phase.
DIR	Device Interface Routine.
DL	Data Link (layer).
DLCI	Data Link Connection Identifier.
DLD	Data Link Discriminator.
DLNB	Diversity Low Noise Block.
DLSP	Data Link Service Process.
DLSP	Digital Link Signalling Processor.
Dm	Control channel (ISDN terminology applied to mobile service).
DMA	Deferred Maintenance Alarm. An alarm report level; an immediate or deferred response is required (see also <i>PMA</i>).
DMA	Direct Memory Access.
DMR	Digital Mobile Radio.
DMX	Distributed Electronic Mobile Exchange (Motorola's networked EMX family).
DN	Directory Number.
DNIC	Data network identifier.
Downlink	Physical link from the BTS towards the MS (BTS transmits, MS receives).
DP	Dial/Dialled Pulse.
DPC	Destination Point Code. A part of the label in a signalling message that uniquely identifies, in a signalling network, the (signalling) destination point of the message.
DPC	Digital Processing and Control board.

DPNSS	Digital Private Network Signalling System (BT standard for PABX interface).
DPP	Dual Path Preselector.
DPR, DPRAM	Dual Port Random Access Memory.
DPSM	Digital Power Supply Module.
DRAM	Dynamic Random Access Memory.
DRC	Data Rate Converter board. Provides data and protocol conversion between PLMN and destination network for 8 circuits (p/o IWF).
DRCU	Diversity Radio Channel Unit. Contains transceiver, digital control circuits, and power supply (p/o BSS) (see <i>RCU</i>).
(D)RCU	Generic term for radio channel unit. May be standard RCU or diversity radio channel unit DRCU.
DRI	Digital Radio Interface. Provides encoding/decoding and encryption/decryption for radio channel (p/o BSS).
DRIM	Digital Radio Interface extended Memory. A DRI with extra memory.
DRIX	DRI Extender half size board. Fibre optic link from DRI to BCU (p/o BSS).
DRX, DRx	Discontinuous reception (mechanism). A means of saving battery power (for example in hand-portable units) by periodically and automatically switching the MS receiver on and off.
DS-2	German term for 2 Mbit/s line (PCM interface).
DSE	Data Switching Exchange.
DSI	Digital Speech Interpolation.
DSP	Digital Signal Processor.
DSS1	Digital Subscriber Signalling No 1.
DSSI	Diversity Signal Strength Indication.
DTAP	Direct Transfer Application Part (6-8).
DTE	Data Terminal Equipment.
DTF	Digital Trunk Frame.
DT1	DaTa form 1 (Part of SCCP network connectivity).
DTI	Digital Trunk Interface.
DTMF	Dual Tone Multi-Frequency (tone signalling type).
DTR	Data Terminal Ready signal. Method of flow control (RS232 Interface).
DTRX	Dual Transceiver Module. (Radio used in M-Cell <i>arena</i> and M-Cell <i>arena^{macro}</i>).
DTX, DTx	Discontinuous Transmission (mechanism). A means of saving battery power (for example in hand-portable units) and reducing interference by automatically switching the transmitter off when no speech or data are to be sent.

Dummy burst	A period of carrier less than one timeslot whose modulation is a defined sequence that carries no useful information. A dummy burst fills a timeslot with an RF signal when no information is to be delivered to a channel.
DYNET	DYnamic NETwork. Used to specify BTSs sharing dynamic resources.

E

E	See <i>Erlang</i> .
E Interface	Interface between MSC and MSC.
EA	External Alarms.
EAS	External Alarm System.
Eb/No	Energy per Bit/Noise floor.
EBCG	Elementary Basic Service Group.
EC	Echo Canceller. Performs echo suppression for all voice circuits.
ECB	Provides echo cancelling for telephone trunks for 30 channels (EC).
ECID	The Motorola European Cellular Infrastructure Division.
ECM	Error Correction Mode (facsimile).
Ec/No	Ratio of energy per modulating bit to the noise spectral density.
ECT	Event Counting Tool.
ECT	Explicit Call Transfer supplementary service.
EEL	Electric Echo Loss.
EEPROM	Electrically Erasable Programmable Read Only Memory.
EGSM900	Extended GSM900.
EI	Events Interface. Part of the OMC-R GUI.
EIR	Equipment Identity Register.
EIRP	Effective Isotropic Radiated Power.
EIRP	Equipment Identity Register Procedure.
EL	Echo Loss.
EM	Event Management. An OMC application.
EMC	ElectroMagnetic Compatibility.
EMF	Electro Motive Force.
EMI	Electro Magnetic Interference.
eMLPP	enhanced Multi-Level Precedence and Pre-emption service.
EMMI	Electrical Man Machine Interface.
EMU	Exchange office Management Unit (<i>p/o Horizonoffice</i>)
EMX	Electronic Mobile Exchange (Motorola's MSC family).

en bloc	Fr. — all at once (a CCITT #7 Digital Transmission scheme); En bloc sending means that digits are sent from one system to another ~ (that is, all the digits for a given call are sent at the same time as a group). ~ sending is the opposite of overlap sending. A system using ~ sending will wait until it has collected all the digits for a given call before it attempts to send digits to the next system. All the digits are then sent as a group.
EOT	End of Tape.
EPROM	Erasable Programmable Read Only Memory.
EPSM	Enhanced Power Supply Module (+27 V).
EQB	Equalizer Board. Control circuit for equalization for 8 time slots each with equalizing circuitry and a DSP (p/o RCU).
EQCP	Equalizer Control Processor.
EQ DSP	Equalizer Digitizer Signal Processor.
Erlang	International (dimensionless) unit of traffic intensity defined as the ratio of time a facility is occupied to the time it is available for occupancy. One erlang is equal to 36 CCS. In the US this is also known as a traffic unit (TU).
ERP	Ear Reference Point.
ERP	Effective Radiated Power.
ERR	ERRor.
ESP	Electro-static Point.
ESQL	Embedded SQL (Structured Query Language). An RDBMS programming interface language.
E-TACS	Extended TACS (analogue cellular system, extended).
Ethernet	Type of Local Area Network.
ETR	ETSI Technical Report.
ETS	European Telecommunication Standard.
ETSI	European Telecommunications Standards Institute.
ETX	End of Transmission.
EXEC	Executive Process.

F

F Interface	Interface between MSC and EIR.
FA	Fax Adaptor.
FA	Full Allocation.
FA	Functional Area.
FAC	Final Assembly Code.
FACCH	Fast Associated Control Channel. A GSM dedicated control channel which is associated with a TCH and carries control information after a call is set up (see <i>SDCCH</i>).
FACCH/F	Fast Associated Control Channel/Full rate.
FACCH/H	Fast Associated Control Channel/Half rate.
FB	Frequency correction Burst (see <i>Frequency correction burst</i>).

FC-AL	Fibre Channel Arbitration Loop. (Type of hard disc).
FCCH	Frequency Correction CHannel. A GSM broadcast control channel which carries information for frequency correction of the mobile (MS).
FCP	Fault Collection Process (in BTS).
FCS	Frame Check Sequence.
FDM	Frequency Division Multiplex.
FDMA	Frequency Division Multiple Access.
FDN	Fixed Dialling Number.
FDP	Fault Diagnostic Procedure.
FEC	Forward Error Correction.
FEP	Front End Processor.
FER	Frame Erasure Ratio.
FFS, FS	For Further Study.
FH	Frequency Hopping.
FIB	Forward Indicator Bit.
FIR	Finite Impulse Response (filter type).
FK	Foreign Key. A database column attribute; the foreign key indicates an index into another table.
FM	Fault Management (at OMC).
FM	Frequency Modulation.
FMIC	Fault Management Initiated Clear.
FMUX	Fibre optic MULTipleXer.
FN	Frame Number. Identifies the position of a particular TDMA frame within a hyperframe.
FOA	First Office Application.
FOX	Fibre Optic eXtender.
FR	Full Rate. Refers to the current capacity of a data channel on the GSM air interface, that is, 8 simultaneous calls per carrier (see also <i>HR – Half Rate</i>).
FRU	Field Replaceable Unit.
Frequency correction	Period of RF carrier less than one timeslot whose modulation bit stream allows frequency correction to be performed easily within an MS burst.
FS	Frequency Synchronization.
FSL	Free Space Loss. The decrease in the strength of a radio signal as it travels between a transmitter and receiver. The FSL is a function of the frequency of the radio signal and the distance the radio signal has travelled from the point source.
FSN	Forward Sequence Number.
FTAM	File Transfer, Access, and Management. An ASE which provides a means to transfer information from file to file (OMC).
ftn	forwarded-to number.

FTP Fault Translation Process (in BTS).
 FTP File Transfer Protocol.

G

G Interface Interface between VLR and VLR.
 Gateway MSC An MSC that provides an entry point into the GSM PLMN from another network or service. A gateway MSC is also an interrogating node for incoming PLMN calls.
 GB, Gbyte Gigabyte.
 GBIC Gigabit Interface Converter.
 GCLK Generic Clock board. System clock source, one per site (p/o BSS, BTS, BSC, IWF, RXCDR).
 GCR Group Call Register.
 GDP Generic DSP Processor board. Interchangeable with the XCDR board.
 GDP E1 GDP board configured for E1 link usage.
 GDP T1 GDP board configured for T1 link usage.
 GHz Giga-Hertz (10^9).
 GID Group ID. A unique number used by the system to identify a user's primary group.
 GMB GSM Multiplexer Board (p/o BSC).
 GMR GSM Manual Revision.
 GMSC Gateway Mobile-services Switching Centre (see *Gateway MSC*).
 GMSK Gaussian Minimum Shift Keying. The modulation technique used in GSM.
 GND Ground.
 GOS Grade of Service.
 GPA GSM PLMN Area.
 GPC General Protocol Converter.
 GPROC Generic Processor board. GSM generic processor board: a 68030 with 4 to 16 Mb RAM (p/o BSS, BTS, BSC, IWF, RXCDR).
 GPROC2 Generic Processor board. GSM generic processor board: a 68040 with 32 Mb RAM (p/o BSS, BTS, BSC, IWF, RXCDR).
 GPRS General Packet Radio Service.
 GPS Global Positioning by Satellite.
 GSA GSM Service Area. The area in which an MS can be reached by a fixed subscriber, without the subscriber's knowledge of the location of the MS. A GSA may include the areas served by several GSM PLMNs.
 GSA GSM System Area. The group of GSM PLMN areas accessible by GSM MSs.
 GSM Groupe Spécial Mobile (the committee).
 GSM Global System for Mobile communications (the system).

GSM MS	GSM Mobile Station.
GSM PLMN	GSM Public Land Mobile Network.
GSR	GSM Software Release.
GT	Global Title.
GTE	Generic Table Editor. The Motorola procedure which allows users to display and edit MCDF input files.
Guard period	Period at the beginning and end of timeslot during which MS transmission is attenuated.
GUI	Graphical User Interface.
GUI client	A computer used to display a GUI from an OMC-R GUI application which is being run on a GUI server.
GUI server	A computer used to serve the OMC-R GUI application process running locally (on its processor) to other computers (GUI clients or other MMI processors).
GWY	GateWay (MSC/LR) interface to PSTN.

H

H Interface	Interface between HLR and AUC.
H-M	Human-Machine Terminals.
HAD, HAP	HLR Authentication Distributor.
HANDO, Handover	HANDOver. The action of switching a call in progress from one radio channel to another radio channel. Handover allows established calls to continue by switching them to another radio resource, as when an MS moves from one BTS area to another. Handovers may take place between the following GSM entities: timeslot, RF carrier, cell, BTS, BSS and MSC.
HCU	Hybrid Combining Unit. (Used in <i>Horizonmacro</i>).
HDLC	High level Data Link Control.
HDSL	High bit-rate Digital Subscriber Line.
HLC	High Layer Compatibility. The HLC can carry information defining the higher layer characteristics of a teleservice active on the terminal.
HLR	Home Location Register. The LR where the current location and all subscriber parameters of an MS are permanently stored.
HMS	Heat Management System. The system that provides environmental control of the components inside the ExCell, TopCell and M-Cell cabinets.
HO	HandOver. (see <i>HANDO</i> above).
HPU	Hand Portable Unit.
HOLD	Call hold supplementary service.
HPLMN	Home PLMN.
HR	Half Rate. Refers to a type of data channel that will double the current GSM air interface capacity to 16 simultaneous calls per carrier (see also <i>FR – Full Rate</i>).
HS	HandSet.

HSI/S	High Speed Interface card.
HSM	HLR Subscriber Management.
HSN	Hopping Sequence Number.
HU	Home Units.
HW	Hardware.
Hyperframe	2048 superframes. The longest recurrent time period of the frame structure.

I	Information frames (RLP).
IA	Incoming Access (closed user group (CUG) SS (supplementary service)).
IA5	International Alphanumeric 5.
IADU	Integrated Antenna Distribution Unit. (The IADU is the equivalent of the Receive Matrix used on pre-M-Cell BTSs).
IAM	Initial Address Message.
IAS	Internal Alarm System.
IC	Integrated Circuit.
IC	Interlock Code (CUG SS).
IC(pref)	Interlock Code op the preferential CUG.
ICB	Incoming Calls Barred.
ICC	Integrated Circuit(s) Card.
ICM	In-Call Modification.
ICMP	Internet Control Message Protocol.
ID, Id	IDentification/IDentity/IDentifier.
IDN	Integrated Digital Network.
IDS	INFOMIX Database Server. (OMC-R relational database management system).
IE	Information Element (signalling).
IEC	International Electrotechnical Commission.
IEEE	Institute of Electrical and Electronic Engineers.
IEI	Information Element Identifier.
I-ETS	Interim European Telecommunication Standard.
IF	Intermediate Frequency.
IFAM	Initial and Final Address Message.
IM	InterModulation.
IMACS	Intelligent Monitor And Control System.
IMEI	International Mobile station Equipment Identity. Electronic serial number that uniquely identifies the MS as a piece or assembly of equipment. The IMEI is sent by the MS along with request for service.
IMM	IMMEDIATE assignment message.

IMSI	International Mobile Subscriber Identity. Published mobile number (prior to ISDN) (see also <i>MSISDN</i>) that uniquely identifies the subscription. It can serve as a key to derive subscriber information such as directory number(s) from the HLR.
IN	Intelligent Network.
IN	Interrogating Node. A switching node that interrogates an HLR, to route a call for an MS to the visited MSC.
INS	IN Service.
INS	Intelligent Network Service.
InterAlg	Interference Algorithm. A single interference algorithm in a cell.
Interworking	The general term used to describe the inter-operation of networks, services, supplementary services and so on. See also <i>IWF</i> .
Interval	A recording period of time in which a statistic is pegged.
Interval expiry	The end of an interval.
I/O	Input/Output.
IOS	Intelligent Optimization Platform.
IP	Initialisation Process.
IP	Internet Protocol.
IPC	Inter-Process Communication.
IP, INP	INtermodulation Products.
IPR	Intellectual PProperty.
IPSM	Integrated Power Supply Module (–48 V).
IPX	(A hardware component).
ISAM	Indexed Sequential Access Method.
ISC	International Switching Centre.
ISDN	Integrated Services Digital Network. An integrated services network that provides digital connections between user-network interfaces.
ISG	Motorola Information Systems group (formally CODEX).
ISO	International Organisation for Standardization.
ISQL	Informix Structured Query Language.
ISUP	ISDN User Part (of signalling system No. 7).
IT	Inactivity Test (Part of SCCP network connectivity).
ITC	Information Transfer Capability.
ITU	International Telecommunication Union.
ITU–TSS	International Telecommunication Union – Telecommunications Sector.
IWF	InterWorking Function. A network functional entity which provides network interworking, service interworking, supplementary service interworking or signalling interworking. It may be a part of one or more logical or physical entities in a GSM PLMN.

IWMSC	InterWorking MSC.
IWU	InterWorking Unit.

K

k	kilo (10^3).
k	Windows size.
K	Constraint length of the convolutional code.
KAIO	Kernal Asynchronous Input/Output.
kb, kbit	kilo-bit.
kbit/s, kbps	kilo-bits per second.
kbyte	kilobyte.
Kc	Ciphering key. A sequence of symbols that controls the operation of encipherment and decipherment.
kHz	kilo-Hertz (10^3).
Ki	Individual subscriber authentication Key (p/o authentication process of AUC).
KIO	A class of processor.
KSW	Kiloport SWitch board. TDM timeslot interchanger to connect calls (p/o BSS).
KSWX	KSW Expander half size board. Fibre optic distribution of TDM bus (p/o BSS).
kW	kilo-Watt.

L

L1	Layer 1.
L2ML	Layer 2 Management Link.
L2R	Layer 2 Relay function. A function of an MS and IWF that adapts a user's known layer2 protocol LAPB onto RLP for transmission between the MT and IWF.
L2R BOP	L2R Bit Orientated Protocol.
L2R COP	L2R Character Orientated Protocol.
L3	Layer 3.
LA	Location Area. An area in which an MS may move freely without updating the location register. An LA may comprise one or several base station areas.
LAC	Location Area Code.
LAI	Location Area Identity. The information indicating the location area in which a cell is located.
LAN	Local Area Network.
LANX	LAN Extender half size board. Fibre optic distribution of LAN to/from other cabinets (p/o BSS etc).
LAPB	Link Access Protocol Balanced (of ITU-TSS Rec. x.25).
LAPD	Link Access Protocol Data.
LAPDm	Link Access Protocol on the Dm channel.

LC	Inductor Capacitor (type of filter).
LCF	Link Control Function.
LCN	Local Communications Network.
LCP	Link Control Processor.
LE	Local Exchange.
LED	Light Emitting Diode.
LF	Line Feed.
LI	Length Indicator.
LI	Line Identity.
LLC	Lower Layer Compatibility. The LLC can carry information defining the lower layer characteristics of the terminal.
Lm	Traffic channel with capacity lower than a Bm.
LMP	LAN Monitor Process.
LMS	Least Mean Square.
LMSI	Local Mobile Station Identity. A unique identity temporarily allocated to visiting mobile subscribers in order to speed up the search for subscriber data in the VLR, when the MSRN allocation is done on a per cell basis.
LMT	Local Maintenance Terminal.
LNA	Low Noise Amplifier.
LND	Last Number Dialed.
Location area	An area in which a mobile station may move freely without updating the location register. A location area may comprise one or several base station areas.
LPC	Linear Predictive Code.
LPLMN	Local PLMN.
LR	Location Register. The GSM functional unit where MS location information is stored. The HLR and VLR are location registers.
LSSU	Link Stations Signalling Unit (Part of MTP transport system).
LSTR	Listener Side Tone Rating.
LTA	Long Term Average. The value required in a BTS's GCLK frequency register to produce a 16.384 MHz clock.
LTE	Local Terminal Emulator.
LTP	Long Term Predictive.
LTU	Line Terminating Unit.
LU	Local Units.
LU	Location Update.
LV	Length and Value.

M

M	Mandatory.
M	Mega (10^6).

M-Cell	Motorola Cell.
M&TS	Maintenance and Troubleshooting. Functional area of Network Management software which (1) collects and displays alarms, (2) collects and displays Software/Hardware errors, and (3) activates test diagnostics at the NEs (OMC).
MA	Mobile Allocation. The radio frequency channels allocated to an MS for use in its frequency hopping sequence.
MAC	Medium Access Control.
MACN	Mobile Allocation Channel Number.
Macrocell	A cell in which the base station antenna is generally mounted away from buildings or above rooftop level.
MAF	Mobile Additional Function.
MAH	Mobile Access Hunting supplementary service.
MAI	Mobile Allocation Index.
MAIDT	Mean Accumulated Intrinsic Down Time.
MAINT	MAINTenance.
MAIO	Mobile Allocation Index Offset.
MAP	Mobile Application Part (of signalling system No. 7). The inter-networking signalling between MSCs and LRs and EIRs.
MAPP	Mobile Application Part Processor.
MB, Mbyte	Megabyte.
Mbit/s	Megabits per second.
MCAP	Motorola Cellular Advanced Processor.
MCC	Mobile Country Code.
MCDF	Motorola Customer Data Format used by DataGen for simple data entry and retrieval.
MCI	Malicious Call Identification supplementary service.
MCSC	Motorola Customer Support Centre.
MCU	Main Control Unit for M-Cell ^{2/6} . Also referred to as the Micro Control Unit in software.
MCUF	Main Control Unit, with dual FMUX. (Used in M-Cell ^{horizon}).
MCU-m	Main Control Unit for M-Cell Micro sites (M-Cell ^m). Also referred to as the Micro Control Unit in software.
MCUm	The software subtype representation of the Field Replaceable Unit (FRU) for the MCU-m.
MD	Mediation Device.
MDL	(mobile) Management (entity) - Data Link (layer).
ME	Maintenance Entity (GSM Rec. 12.00).
ME	Mobile Equipment. Equipment intended to access a set of GSM PLMN and/or DCS telecommunication services, but which does not contain subscriber related information. Services may be accessed while the equipment, capable of surface movement within the GSM system area, is in motion or during halts at unspecified points.
MEF	Maintenance Entity Function (GSM Rec. 12.00).

MF	MultiFrame.
MF	Multi-Frequency (tone signalling type).
MF	MultiFunction block.
MGMT, mgmt	Management.
MGR	Manager.
MHS	Message Handling System.
MHS	Mobile Handling Service.
MHz	Mega-Hertz (10^6).
MI	Maintenance Information.
MIB	Management Information Base. A Motorola OMC-R database. There is a CM MIB and an EM MIB.
MIC	Mobile Interface Controller.
Microcell	A cell in which the base station antenna is generally mounted below rooftop level. Radio wave propagation is by diffraction and scattering around buildings, the main propagation is within street canyons.
min	minute(s).
μ s	micro-second (10^{-6}).
μ BCU	Micro Base Control Unit.
MIT	Management Information Tree. Name of a file on the Motorola OMC-R.
MM	Man Machine.
MM	Mobility Management.
MME	Mobile Management Entity.
MMF	Middle Man Funnel process.
MMI	Man Machine Interface. The method in which the user interfaces with the software to request a function or change parameters.
MMI client	A machine configured to use the OMC-R software from an MMI server.
MMI processor	MMI client/MMI server.
MMI server	A computer which has its own local copy of the OMC-R software. It can run the OMC-R software for MMI clients to mount.
MML	Man Machine Language. The tool of MMI.
MMS	Multiple Serial Interface Link. (<i>see also 2Mbit/s link</i>)
MNC	Mobile Network Code.
MNT	MaiNTenance.
MO	Mobile Originated.
MO/PP	Mobile Originated Point-to-Point messages.
MOMAP	Motorola OMAP.
MoU	Memorandum of Understanding.
MPC	Multi Personal Computer (was p/o OMC).

MPH	(mobile) Management (entity) - PPhysical (layer) [primitive].
MPTY	MultiParTY (Multi ParTY) supplementary service.
MPX	MultiPleXed.
MRC	Micro Radio Control Unit.
MRN	Mobile Roaming Number.
MRP	Mouth Reference Point.
MS	Mobile Station. The GSM subscriber unit.
MSC	Mobile-services Switching Centre, Mobile Switching Centre.
MSCM	Mobile Station Class Mark.
MSCU	Mobile Station Control Unit.
msec	millisecond (.001 second).
MSI	Multiple Serial Interface board. Intelligent interface to two 2 Mbit/s digital links (see <i>2 Mbit/s link</i> and <i>DS-2</i>) (p/o BSS).
MSIN	Mobile Station Identification Number.
MSISDN	Mobile Station International ISDN Number. Published mobile number (see also IMSI). Uniquely defines the mobile station as an ISDN terminal. It consists of three parts: the Country Code (CC), the National Destination Code (NDC) and the Subscriber Number (SN).
MSRN	Mobile Station Roaming Number. A number assigned by the MSC to service and track a visiting subscriber.
MSU	Message Signal Unit (Part of MTP transport system). A signal unit containing a service information octet and a signalling information field which is retransmitted by the signalling link control, if it is received in error.
MT	Mobile Terminated. Describes a call or short message destined for an MS.
MT (0, 1, 2)	Mobile Termination. The part of the MS which terminates the radio transmission to and from the network and adapts terminal equipment (TE) capabilities to those of the radio transmission. MT0 is mobile termination with no support for terminal, MT1 is mobile termination with support for an S-type interface and MT2 is mobile termination with support for an R-type interface.
MTM	Mobile-To-Mobile (call).
MTP	Message Transfer Part.
MT/PP	Mobile Terminated Point-to-Point messages.
MTBF	Mean Time Between Failures.
MTK	Message Transfer Link.
MTL	MTP Transport Layer Link (A interface).
MTP	Message Transfer Part.
MTTR	Mean Time To Repair.
Multiframe	Two types of multiframe are defined in the system: a 26-frame multiframe with a period of 120 ms and a 51-frame multiframe with a period of 3060/13 ms.
MU	Mark Up.

MUMS Multi User Mobile Station.
 MUX Multiplexer.

N

N/W Network.
 NB Normal Burst (see *Normal burst*).
 NBIN A parameter in the hopping sequence.
 NCC Network (PLMN) Colour Code.
 NCELL Neighbouring (of current serving) Cell.
 NCH Notification CHannel.
 ND No Duplicates. A database column attribute meaning the column contains unique values (used only with indexed columns).
 NDC National Destination Code.
 NDUB Network Determined User Busy.
 NE Network Element (Network Entity).
 NEF Network Element Function block.
 NET Norme Européennes de Telecommunications.
 NETPlan Frequency planning tool.
 NF Network Function.
 NFS Network File System.
 NHA Network Health Analyst. Optional OMC-R processor feature.
 NIC Network Interface Card.
 NIC Network Independent Clocking.
 NIS Network Information Service. It allows centralised control of network information for example hostnames, IP addresses and passwords.
 NIU Network Interface Unit.
 NIU-m Network Interface Unit, micro.
 NLK Network LinK processor(s).
 Nm Newton metres.
 NM Network Management (manager). NM is all activities which control, monitor and record the use and the performance of resources of a telecommunications network in order to provide telecommunication services to customers/users at a certain level of quality.
 NMASE Network Management Application Service Element.
 NMC Network Management Centre. The NMC node of the GSM TMN provides global and centralised GSM PLMN monitoring and control, by being at the top of the TMN hierarchy and linked to subordinate OMC nodes.
 NMSI National Mobile Station Identification number.
 NMT Nordic Mobile Telephone system.

NN	No Nulls. A database column attribute meaning the column must contain a value in all rows.
Normal burst	A period of modulated carrier less than a timeslot.
NPI	Number Plan Identifier.
NRZ	Non Return to Zero.
NSAP	Network Service Access Point.
NSP	Network Service Provider.
NSS	Network Status Summary.
NT	Network Termination.
NT	Non Transparent.
NTAAB	New Type Approval Advisory Board.
NUA	Network User Access.
NUI	Network User Identification.
NUP	National User Part (of signalling system No. 7).
NV	NonVolatile.
NVRAM	Non-Volatile Random Access Memory.
nW	Nano-Watt (10^{-9}).

O

O	Optional.
OA	Outgoing Access (CUG SS).
O&M	Operations and Maintenance.
OASCU	Off-Air-Call-Set-Up. The procedure in which a telecommunication connection is being established whilst the RF link between the MS and the BTS is not occupied.
OCB	Outgoing Calls Barred within the CUG.
OCXO	Oversized Voltage Controlled Crystal Oscillator.
OD	Optional for operators to implement for their aim.
OFL	% OverFlow.
offline	IDS shutdown state.
online	IDS normal operatng state.
OIC	Operator Initiated Clear.
OLM	Off_Line MIB. A Motorola DataGen database, used to modify and carry out Radio Frequency planning on multiple BSS binary files.
OLR	Overall Loudness Rating.
OMAP	Operations and Maintenance Application Part (of signalling system No. 7) (was OAMP).
OMC	Operations and Maintenance Centre. The OMC node of the GSM TMN provides dynamic O&M monitoring and control of the PLMN nodes operating in the geographical area controlled by the specific OMC.
OMC-G	Operations and Maintenance Centre — Gateway Part. (Iridium)

OMC-G	Operations and Maintenance Centre — GPRS Part.
OMC-R	Operations and Maintenance Centre — Radio Part.
OMC-S	Operations and Maintenance Centre — Switch Part.
OMF	Operations and Maintenance Function (at BSC).
OML	Operations and Maintenance Link.
OMP	Operation and Maintenance Processor.
OMS	Operation and Maintenance System (BSC–OMC).
OMSS	Operation and Maintenance SubSystem.
OOS	Out Of Service.
OPC	Originating Point Code. A part of the label in a signalling message that uniquely identifies, in a signalling network, the (signalling) origination point of the message.
ORAC	Olympus Radio Architecture Chipset.
OS	Operating System.
OSI	Open Systems Interconnection.
OSI RM	OSI Reference Model.
OSF	Operation Systems Function block.
OSF/MOTIF	Open Software Foundation Motif. The basis of the GUI used for the Motorola OMC-R MMI.
OSS	Operator Services System.
Overlap	Overlap sending means that digits are sent from one system to another as soon as they are received by the sending system. A system using ~ will not wait until it has received all digits of a call before it starts to send the digits to the next system. This is the opposite of en bloc sending where all digits for a given call are sent at one time.

P

PA	Power Amplifier.
PAB	Power Alarm Board.
PABX	Private Automatic Branch eXchange.
PAD	Packet Assembler/Disassembler facility.
Paging	The procedure by which a GSM PLMN fixed infrastructure attempts to reach an MS within its location area, before any other network-initiated procedure can take place.
PATH	CEPT 2 Mbit/s route through the BSS network.
PBUS	Processor Bus.
PBX	Private Branch eXchange.
PC	Personal Computer.
PCH	Paging CHannel. A GSM common control channel used to send paging messages to the MSs.
PCHN	Paging Channel Network.
PCHN	Physical Channel.

PCM	Pulse Code Modulation (see also <i>2 Mbit/s link</i> which is the physical bearer of PCM).
PCN	Personal Communications Network.
PCR	Preventative Cyclic Retransmission. A form of error correction suitable for use on links with long transmission delays, such as satellite links.
PCU	Packet Control Unit (p/o GPRS).
PCU	Picocell Control unit (p/o M-Cellaccess).
pd	Potential difference.
PD	Protocol Discriminator.
PD	Public Data.
PDB	Power Distribution Board.
PDF	Power Distribution Frame (MSC/LR).
PDN	Public Data Networks.
PDU	Power Distribution Unit.
PDU	Protected Data Unit.
PEDC	Pan European Digital Cellular.
Peg	A single incremental action modifying the value of a statistic.
Pegging	Modifying a statistical value.
PH	Packet Handler.
PH	PHysical (layer).
PHI	Packet Handler Interface.
PI	Presentation Indicator.
Picocell	A cell site where the base station antenna is mounted within a building.
PICS	Protocol Implementation Conformance Statement.
PID	Process IDentifier/Process ID.
PIM	PCM Interface Module (MSC).
PIN	Personal Identification Number.
PIN	Problem Identification Number.
PIX	Parallel Interface Extender half size board. Customer alarm interface (p/o BSS).
PIXT	Protocol Implementation eXtra information for Testing.
PK	Primary Key. A database column attribute, the primary key is a not-null, non-duplicate index.
Plaintext	Unciphered data.
PlaNET	Frequency planning tool.
PLL	Phase Lock Loop (refers to phase locking the GCLK in the BTS).
PLMN	Public Land Mobile Network. The mobile communications network.
PM	Performance Management. An OMC application.
PM-UI	Performance Management User Interface.

PMA	Prompt Maintenance Alarm. An alarm report level; immediate action is necessary (see also <i>DMA</i>).
PMS	Pseudo MMS.
PMUX	PCM MULTipleXer.
PN	Permanent Nucleus (of GSM).
PNE	Présentation des Normes Européennes.
POI	Point of Interconnection (with PSTN).
POTS	Plain Old Telephone Service (basic telephone services).
p/o	Part of.
pp, p-p	Peak-to-peak.
PP	Point-to-Point.
ppb	Parts per billion.
PPE	Primitive Procedure Entity.
ppm	Parts per million ($\times 10^{-6}$).
Pref CUG	Preferential CUG.
Primary Cell	A cell which is already optimized in the network and has a co-located neighbour whose cell boundary follows the boundary of the said cell. The primary cell has a preferred band equal to the frequency type of the coincident cell.
PROM	Programmable Read Only Memory.
Ps	Location probability.
PSA	Periodic Supervision of Accessibility.
PSAP	Presentation Services Access Point.
PSM	Power Supply Module.
PSPDN	Packet Switched Public Data Network. Public data communications network. x.25 links required for NE to OMC communications will probably be carried by PSPDN.
PSTN	Public Switched Telephone Network. The UK land line telephone network.
PSU	Power Supply Unit.
PSW	Pure Sine Wave.
PTO	Public Telecommunications Operator.
PUCT	Price per Unit Currency Table.
PVC	Permanent Virtual Circuit.
PW	Pass Word.
PWR	Power.
PXPDN	Private eXchange Public Data Network.
Q	
QA	Q (Interface) – Adapter.
Q3	Interface between NMC and GSM network.
Q-adapter	Used to connect MEs and SEs to TMN (GSM Rec. 12.00).
QAF	Q-Adapter Function.

Q

QEI	Quad European Interface. Interfaces four 2 Mbit/s circuits to TDM switch highway (see <i>MSI</i>).
QIC	Quarter Inch Cartridge (Data storage format).
QOS	Quality Of Service.
Quiescent mode	IDS intermediate state before shutdown.

R

R	Value of reduction of the MS transmitted RF power relative to the maximum allowed output power of the highest power class of MS (A).
RA	RAndom mode request information field.
RAB	Random Access Burst.
RACCH	Random Access Control CHannel. A GSM common control channel used to originate a call or respond to a page.
RACH	Random Access CHannel.
RAM	Random Access Memory.
RAND	RANdOm number (used for authentication).
RATI	Receive Antenna Transceiver Interface.
RAx	Rate Adaptation.
RBDS	Remote BSS Diagnostic System (a discontinued Motorola diagnostic facility).
RBER	Residual Bit Error Ratio.
RBTS	Remote Base Transceiver Station.
RCB	Radio Control Board (p/o DRCU).
RCI	Radio Channel Identifier.
RCP	Radio Control Processor.
RCU	Radio Channel Unit. Contains transceiver, digital control circuits, and power supply (p/o BSS) (see <i>DRCU</i>).
RCVR	Receiver.
RDBMS	Relational DataBase Management System (INFORMIX).
RDI	Radio Digital Interface System.
RDIS	Restricted Digital Information.
RDM	Reference Distribution Module.
RDN	Relative Distinguished Name. A series of RDN form a unique identifier, the distinguished name, for a particular network element.
REC, Rec	RECommendation.
REJ	REJect(ion).
REL	RELease.
REL P	Residual Excited Linear Predictive.
REL P-LTP	REL P Long Term Prediction. A name for GSM full rate (see <i>full rate</i>).
resync	Resynchronize/resynchronization.
REQ	REQuest.

Revgen	A Motorola DataGen utility for producing an MMI script from a binary object database.
RF	Radio Frequency.
RFC, RFCH	Radio Frequency Channel. A partition of the system RF spectrum allocation with a defined bandwidth and centre frequency.
RFE	Receiver Front End (shelf).
RFEB	Receiver Front End Board (p/o DRCU II).
RFI	Radio Frequency Interference.
RFM	Radio Frequency Module.
RFN	Reduced TDMA Frame Number.
RFU	Reserved for Future Use.
RJ45	Network cable/Connector type.
RISC	Reduced Instruction Set Computer.
RL	Remote login.
RLC	Release Complete.
RLP	Radio Link Protocol. An ARQ protocol used to transfer user data between an MT and IWF. See GSM 04.22.
RLR	Receiver Loudness Rating.
RLSD	ReLeaSeD.
RMS	Root Mean Square (value).
RMSU	Remote Mobile Switching Unit.
RNTABLE	Table of 128 integers in the hopping sequence.
ROM	Read Only Memory.
ROSE	Remote Operations Service Element. An ASE which carries a message between devices over an association established by ASCE (a CCITT specification for O & M) (OMC).
Roundtrip	Time period between transmit and receive instant of a timeslot in the BTS, propagation determined by the response behaviour of the MS and the MS to BTS delay distance.
RPE	Regular Pulse Excited.
RPE-LTP	Regular Pulse Excitation - Long Term Prediction. The GSM digital speech coding scheme.
RPOA	Recognised Private Operating Agency.
RPR	Read Privilege Required. Access to the column is allowed only for privileged accounts.
RR	Radio Resource management.
RR	Receive Ready (frame).
RRSM	Radio Resource State Machine.
RS232	Standard serial interface.
RSE	Radio System Entity.
RSL	Radio Signalling Link.
RSLF	Radio System Link Function.

RSLP	Radio System Link Processor.
RSS	Radio SubSystem (replaced by BSS).
RSSI	Received Signal Strength Indicator.
RSZI	Regional Subscription Zone Identity.
RTC	Remotely Tuneable Channel Combiner.
RTE	Remote Terminal Emulator.
RTF	Radio Transceiver Function.
RTF	Receive Transmit Functions.
RTS	Request to Send. Method of flow control (RS232 Interface).
RU	Rack Unit.
Run level	System processor operating mode.
Rx	Receive(r).
RXCDR	Remote Transcoder.
RXF	Receive Function (of the RTF).
RXLEV-D	Received signal level downlink.
RXLEV-U	Received signal level uplink.
RXQUAL-D	Received signal quality downlink.
RXQUAL-U	Received signal quality uplink.
RXU	Remote Transcoder Unit. The shelf which houses the remote transcoder modules in a BSS cabinet at a remote transcoder site.

S

S/W	SoftWare.
SABM	Set Asynchronous Balanced Mode. A message which establishes the signalling link over the air interface.
SABME	SABM Extended.
SACCH	Slow Associated Control CHannel. A GSM control channel used by the MS for reporting RSSI and signal quality measurements.
SACCH/C4	Slow Associated Control CHannel/SDCCH/4.
SACCH/C8	Slow Associated Control CHannel/SDCCH/8.
SACCH/T	Slow Associated Control CHannel/Traffic channel.
SACCH/TF	Slow Associated Control CHannel/Traffic channel Full rate.
SACCH/TH	Slow Associated Control CHannel/Traffic channel Half rate.
SAGE	A brand of trunk test equipment.
SAP	Service Access Point. In the reference model for OSI, SAPs of a layer are defined as gates through which services are offered to an adjacent higher layer.
SAP	System Audits Process.
SAPI	Service Access Point Indicator (identifier).
SAW	Surface Acoustic Wave.
SB	Synchronization Burst (see <i>Synchronization burst</i>).

SBUS	Serial Bus.
SC	Service Centre (used for Short Message Service).
SC	Service Code.
SCCA	System Change Control Administration. Software module which allows full or partial software download to the NE (OMC).
SCCP	Signalling Connection Control Part (6-8).
SCEG	Speech Coding Experts Group (of GSM).
SCH	Synchronization CHannel. A GSM broadcast control channel used to carry information for frame synchronization of MSs and identification of base stations.
SCI	Status Control Interface.
SCIP	Serial Communication Interface Processor.
SCM	Status Control Manager.
SCN	Sub-Channel Number. One of the parameters defining a particular physical channel in a BS.
SCP	Service Control Point (an intelligent network entity).
SCSI	Small Computer Systems Interface.
SCU	Slim Channel Unit.
SCU900	Slim Channel Unit for GSM900.
SDCCH	Stand-alone Dedicated Control CHannel. A GSM control channel where the majority of call setup occurs. Used for MS to BTS communications before MS assigned to TCH.
SDL	Specification Description Language.
SDT	SDL Development Tool.
SDU	Service Data Unit.
SDR	Special Drawing Rights (an international "basket" currency for billing).
SE	Support Entity (GSM Rec. 12.00).
Secondary Cell	A cell which is not optimized in the network and has a co-located neighbour whose cell boundary follows the boundary of the said cell. The secondary cell has a preferred band the same as that of its own frequency type.
SEF	Support Entity Function (GSM Rec.12.00).
SFH	Slow Frequency Hopping.
SI	Screening Indicator.
SI	Service Interworking.
SI	Supplementary Information.
SIA	Supplementary Information A.
SID	Silence Descriptor.
SIF	Signal Information Field. The bits of a message signal unit that carry information for a certain user transaction; the SIF always contains a label.

SIM	Subscriber Identity Module. Removable module which is inserted into a mobile equipment; it is considered as part of the MS. It contains security related information (IMSI, Ki, PIN), other subscriber related information and the algorithms A3 and A8.
SIMM	Single Inline Memory module.
SIMM	System Integrated Memory Module.
SIO	Service Information Octet. Eight bits contained in a message signal unit, comprising the service indicator and sub-service field.
SITE	BSC, BTS or collocated BSC-BTS site.
SIX	Serial Interface eXtender. Converts interface levels to TTL levels. Used to extend 2 serial ports from GPROC to external devices (RS232, RS422, and fibre optics).
SK	Secondary Key. A database column attribute, the secondary key indicates an additional index and/or usage as a composite key.
SL	Signalling Link.
SLNK	Serial Link.
SLR	Send Loudness Rating.
SLTM	Signalling Link Test Message.
SM	Switch Manager.
SM	Summing Manager.
SMAE	System Management Application Entity (CCITT Q795, ISO 9596).
SMCB	Short Message Cell Broadcast.
SME	Short Message Entity.
SMG	Special Mobile Group.
SMP	Motorola Software Maintenance Program.
SMS	Short Message Service.
SMSCB	Short Message Service Cell Broadcast.
SMS-SC	Short Message Service - Service Centre.
SMS/PP	Short Message Service/Point-to-Point.
Smt	Short message terminal.
SN	Subscriber Number.
SND	SeND.
SNDR	SeNDeR.
SNR	Serial Number.
SOA	Suppress Outgoing Access (CUG SS).
SP	Service Provider. The organisation through which the subscriber obtains GSM telecommunications services. This may be a network operator or possibly a separate body.
SP	Signalling Point.
SP	Special Product.

SP	SPare.
SPC	Signalling Point Code.
SPC	Suppress Preferential CUG.
SPI	Signalling Point Inaccessible.
SPP	Single Path Preselector.
SQE	Signal Quality Error.
SQL	Structured Query Language.
SRD	Service Request Distributor.
SRES	Signed RESponse (authentication).
SS	Supplementary Service. A modification of, or a supplement to, a basic telecommunication service.
SS	System Simulator.
SSA	SCCP messages, Subsystem-allowed (see CCITT Q.712 para 1.15).
SSAP	Site System Audits Processor.
SSC	Supplementary Service Control string.
SSF	Subservice Field. The level 3 field containing the network indicator and two spare bits.
SSM	Signalling State Machine.
SSN	SubSystem Number.
SSP	Service Switching Point (an intelligent network element).
SSP	SCCP messages, Subsystem-prohibited (see CCITT Q.712 para 1.18).
SSP	SubSystem Prohibited message.
SSS	Switching SubSystem (comprising the MSC and the LRs).
SS7	ANSI Signalling System No. 7 (alias C7).
STAN	Statistical ANalysis (processor).
STAT	STATistics.
stats	Statistics.
STC	System Timing Controller.
STMR	Side Tone Masking rating.
SUERM	Signal Unit Error Rate Monitor.
STP	Signalling Transfer Point.
Superframe	51 traffic/associated control multiframes or 26 broadcast/common control multiframes (period 6.12s).
Super user	User account that can access all files, regardless of protection settings, and control all user accounts.
SURF	Sectorized Universal Receiver Front-end (Used in Horizon <i>macro</i>).
SVC	Switch Virtual Circuit.
SVM	SerVice Manager.
SVN	Software Version Number.

SW	Software.
SWFM	SoftWare Fault Management.
sync	synchronize/synchronization.
Synchronization burst	Period of RF carrier less than one timeslot whose modulation bit stream carries information for the MS to synchronize its frame to that of the received signal.
SYS	SYStem.
SYSGEN	SYStem GENeration. The Motorola procedure for loading a configuration database into a BTS.

T

T	Timer.
T	Transparent.
T	Type only.
T43	Type 43 Interconnect Board. Provides interface to 12 unbalanced (6-pair) 75 ohm (T43 coax connectors) lines for 2 Mbit/s circuits (See <i>BIB</i>).
TA	Terminal Adaptor. A physical entity in the MS providing terminal adaptation functions (see GSM 04.02).
TA	Timing Advance.
TAC	Type Approval Code.
TACS	Total Access Communications System (European analogue cellular system).
TAF	Terminal Adaptation Function.
TATI	Transmit Antenna Transceiver Interface. The TATI consists of RF combining equipments, either Hybrid or Cavity Combining. (See CCB).
TAXI	Transparent Asynchronous Transmitter/Receiver Interface (physical layer).
TBD	To Be Determined.
TBR	Technical Basis for Regulation.
TBUS	TDM Bus.
TC	Transaction Capabilities.
TCAP	Transaction Capabilities Application Part (of Signalling System No. 7).
TCB	TATI Control Board.
TCH	Traffic CHannel. GSM logical channels which carry either encoded speech or user data.
TCH/F	A full rate TCH.
TCH/F2.4	A full rate TCH at ≤ 2.4 kbit/s.
TCH/F4.8	A full rate TCH at 4.8 kbit/s.
TCH/F9.6	A full rate TCH at 9.6 kbit/s.
TCH/FS	A full rate Speech TCH.
TCH/H	A half rate TCH.
TCH/H2.4	A half rate TCH at ≤ 2.4 kbit/s.

TCH/H4.8	A half rate TCH at 4.8 kbit/s.
TCH/HS	A half rate Speech TCH).
TCI	Transceiver Control Interface.
TCP/IP	Transmission Control Protocol/Internet Protocol.
TC-TR	Technical Committee Technical Report.
TCU	Transceiver Control Unit.
TDF	Twin Duplexed Filter. (Used in M-Cell _{horizon}).
TDM	Time Division Multiplexing.
TDMA	Time Division Multiple Access.
TDU	TopCell Digital Unit.
TE	Terminal Equipment. Equipment that provides the functions necessary for the operation of the access protocols by the user.
Tei	Terminal endpoint identifier.
TEI	Terminal Equipment Identity.
TEMP	TEMPorary.
TEST	TEST control processor.
TFA	TransFer Allowed.
TFP	TransFer Prohibited.
TFTP	Trivial File Transfer Protocol.
TI	Transaction Identifier.
Timeslot	The multiplex subdivision in which voice and signalling bits are sent over the air. Each RF carrier is divided into 8 timeslots.
Timing advance	A signal sent by the BTS to the MS. It enables the MS to advance the timing of its transmission to the BTS so as to compensate for propagation delay.
TLV	Type, Length and Value.
TM	Traffic Manager.
TMI	TDM Modem Interface board. Provides analogue interface from IWF to modems for 16 circuits (p/o IWF).
TMM	Traffic Metering and Measuring.
TMN	Telecommunications Management Network. The implementation of the Network Management functionality required for the PLMN is in terms of physical entities which together constitute the TMN.
TMSI	Temporary Mobile Subscriber Identity. A unique identity temporarily allocated by the MSC to a visiting mobile subscriber to process a call. May be changed between calls and even during a call, to preserve subscriber confidentiality.
TN	Timeslot Number.
TON	Type Of Number.
Traffic channels	Channels which carry user's speech or data (see also <i>TCH</i>).
Traffic unit	Equivalent to an erlang.

Training sequence	Sequence of modulating bits employed to facilitate timing recovery and channel equalization in the receiver.
TRAU	Transcoder Rate Adaption Unit.
TRU	TopCell Radio unit.
TRX	Transceiver(s). A network component which can serve full duplex communication on 8 full-rate traffic channels according to specification GSM 05.02. If Slow Frequency Hopping (SFH) is not used, then the TRX serves the communication on one RF carrier.
TS	Technical Specification.
TS	TeleService.
TS	TimeSlot (see <i>Timeslot</i>).
TSA	TimeSlot Acquisition.
TSA	TimeSlot Assignment.
TSDA	Transceiver Speech & Data Interface.
TSC	Training Sequence Code.
TSI	TimeSlot Interchange.
TSDI	Transceiver Speech and Data Interface.
TSM	Transceiver Station Manager.
TSW	Timeslot SWitch.
TTCN	Tree and Tabular Combined Notation.
TTL	Transistor to Transistor Logic.
TTY	TeleTYpe (refers to any terminal).
TU	Traffic Unit.
TUP	Telephone User Part (SS7).
TV	Type and Value.
Tx	Transmit(ter).
TXF	Transmit Function (of the RTF).
TXPWR	Transmit PoWeR. Tx power level in the MS_TXPWR_REQUEST and MS_TXPWR_CONF parameters.
TxBPF	Transmit Bandpass Filter.

U

UA	Unnumbered Acknowledgment. A message sent from the MS to the BSS to acknowledge release of radio resources when a call is being cleared.
UDI	Unrestricted Digital Information.
UDP	User Datagram Protocol.
UDUB	User Determined User Busy.
UHF	Ultra High Frequency.
UI	Unnumbered Information (Frame).
UIC	Union International des Chemins de Fer.

UID	User ID. Unique number used by the system to identify the user.
UL	Upload (of software or database from an NE to a BSS).
Um	Air interface.
UMTS	Universal Mobile Telecommunication System.
UPCMI	Uniform PCM Interface (13 bit).
UPD	Up to Date.
Uplink	Physical link from the MS towards the BTS (MS transmits, BTS receives).
UPS	Uninterruptable Power Supply.
UPU	User Part Unavailable.
Useful part of burst	That part of the burst used by the demodulator; differs from the full burst because of the bit shift of the I and Q parts of the GMSK signal.
USSD	Unstructured Supplementary Service Data.
UUS	User-to-User Signalling supplementary service.

V

V	Value only.
VA	Viterbi Algorithm (used in channel equalizers).
VAD	Voice Activity Detection. A process used to identify presence or absence of speech data bits. VAD is used with DTX.
VAP	Videotex Access Point.
VBS	Voice Broadcast Service.
VC	Virtual Circuit.
VCO	Voltage Controlled Oscillator.
VCXO	Voltage Controlled Crystal Oscillator.
VDU	Visual Display Unit.
VGCS	Voice Group Call Service.
VLR	Visitor Location Register. A GSM network element which provides a temporary register for subscriber information for a visiting subscriber. Often a part of the MSC.
VLSI	Very Large Scale Integration (in ICs).
VMSC	Visited MSC. (Recommendation not to be used).
VOX	Voice Operated Transmission.
VPLMN	Visited PLMN.
VSC	Videotex Service Centre.
V(SD)	Send state variable.
VSP	Vehicular Speaker Phone.
VSWR	Voltage Standing Wave Ratio.
VTX host	The components dedicated to Videotex service.

W

WAN	Wide Area Network.
WPA	Wrong Password Attempts (counter).
WS	Work Station. The remote device via which O&M personnel execute input and output transactions for network management purposes.
WSF	Work Station Function block.
WWW	World Wide Web.

X

X.25	CCITT specification and protocols for public packet-switched networks (see <i>PSPDM</i>).
X.25 link	A communications link which conforms to X.25 specifications and uses X.25 protocol (NE to OMC links).
XBL	Transcoder to BSS Link. The carrier communications link between the Transcoder (XCDR) and the BSS.
XCB	Transceiver Control Board (p/o Transceiver).
XCDR	Full-rate Transcoder. Provides speech transcoding and 4:1 submultiplexing (p/o BSS, BSC or XCDR).
XCDR board	The circuit board required to perform speech transcoding at the BSS or (R)XCDR). Also known as the MSI (XCDR) board. Interchangeable with the GDP board.
XFER	Transfer.
XID	eXchange IDentifier.
X-Term	X terminal window.

Z

ZC	Zone Code
----	-----------

